

Mild and severe muscular dystrophy associated with deletions in Xp21 of the human X chromosome

K E DAVIES*, T J SMITH*, S BUNDEY†, A P READ‡, T FLINT*,
M BELL*, AND A SPEER§

From *the Nuffield Department of Clinical Medicine, University of Oxford, John Radcliffe Hospital, Oxford OX3 9DU; †Infant Development Unit, Birmingham Maternity Hospital, Edgbaston, Birmingham B15 2TG; ‡the Department of Medical Genetics, University of Manchester, St Mary's Hospital, Hathersage Road, Manchester M13 0JH; and §the Department of Cell Differentiation, Institute of Molecular Biology, Academy of Sciences of DDR, Robert Rossle Strasse 10, 115 Berlin, GDR.

SUMMARY We have analysed over 300 patients suffering from Duchenne or Becker muscular dystrophy (DMD or BMD). Deletions have been characterised which encompass either the pERT87 (*DXS164*) locus only, the XJ1.1 (*DXS206*) and HIP25 loci only, or all three loci. These loci have been shown to lie within the DMD region covering several hundred kilobases (kb) of DNA. One mildly affected BMD patient possesses a deletion of at least 110 kb including exons of the DMD gene. Other patients with similar exon deletions, or smaller deletions, show the more severe phenotype typical of DMD. We conclude from these studies that the severity of the clinical phenotype cannot be explained on the basis of the size of the deletion. We discuss this in the context of candidate gene sequences.

Duchenne muscular dystrophy (DMD) is an X linked recessive condition affecting 1 in 3000 males.¹ Affected boys are normally wheelchair bound by the age of 11 or 12 years and die in their late teens. Patients suffering from the clinically milder form of disease, Becker muscular dystrophy (BMD), go into a wheelchair much later and may have a normal life span. These disease loci were thought to lie within Xp21 on the human X chromosome from cytogenetic observations of females suffering from the disease with balanced X;autosomal translocations (for review see Elejalde and Elejalde²). The breakpoints of these translocations lie within the Xp21 band but have been shown to be heterogeneous.³ Studies using DNA markers confirmed the localisation of *DMD* to Xp21 and placed *BMD* in the same region.⁴⁻⁶

Carrier detection and prenatal diagnosis of these disorders has been greatly improved by the use of restriction fragment length polymorphisms (RFLPs) bridging the mutations.⁷ More recently, DNA markers have been isolated which lie within, or very close to, the DMD locus itself. pERT87 was isolated by Kunkel *et al*⁸ and shown to be deleted in 7% of

affected males.⁹ Chromosome walking from this sequence has led to the identification of expressed regions of the DMD gene.¹⁰ The corresponding mRNA is 16 kb, showing that this locus must encode a large protein. The middle filament protein Nebulin, which is 550 kd, has been suggested as a possible candidate protein not only because of its size but also because of its absence in DMD patients.¹¹

Ray *et al*¹² cloned the translocation breakpoint in the female with the X;21 translocation to isolate a DNA marker for the disease, XJ1.1. This has been shown to lie approximately 200 kb centromeric from pERT87 in pulsed field gel electrophoresis studies.¹³⁻¹⁵ This sequence is also deleted in some DMD patients.

We have isolated a sequence, HIP25, by subtractive hybridisation, which is deleted in 7% of DMD patients.¹⁶ In the study presented here we have analysed our patients with pERT87, XJ1.1, and HIP25 together with other markers derived from chromosome walks in the region. These DNA markers cover approximately 1000 kb of the DMD locus.

Methods

DNA EXTRACTION

DNA was extracted according to the method of

Kunkel *et al*¹⁷ and digested with the restriction enzyme *Pst*I according to the manufacturer's instructions.

SOUTHERN BLOT ANALYSIS

Gels were run in 0.8% agarose (BRL) and blotted onto Hybond (Amersham) according to the method of Southern.¹⁸ The blots were hybridised as described previously.⁴

PROBES

Probes pERT87-1, 8, 15, 30, 41, and JBir were kind gifts from Dr Kunkel (Boston). These are described in detail in Monaco *et al*.¹⁹ XJ1.1 was a kind gift from Dr Worton and corresponds to the breakpoint in the X;21 translocation female.¹² HIP25 was isolated in our own laboratory by Smith *et al*.¹⁶ Further information on these probes and others given in the table can be found in Human Gene Mapping 8²⁰ and references 8, 12, 16, and 21.

The DNA segments pERT87 and XJ have been assigned the names *DXS164* and *DXS206* respectively.

Results

We have screened over 300 patients suffering from DMD and BMD with probes from the Xp21 region. The pERT87 locus has been extended by chromosome walking and the subclones that cover this region (pERT87-1, 8, 15, 30, 41) have been used independently. JBir is a deletion junction clone isolated from a DMD patient by Monaco *et al*.¹⁹ XJ1.1 and HIP25 loci are within 20 kb of one another and have so far revealed the same pattern with respect to deletions in patients. Approximately 10% of patients showed deletions with these probes.

A typical blot is shown in fig 1. A series of DMD patients are shown hybridised to the probes pERT87-41 and JBir. Most of these patients are

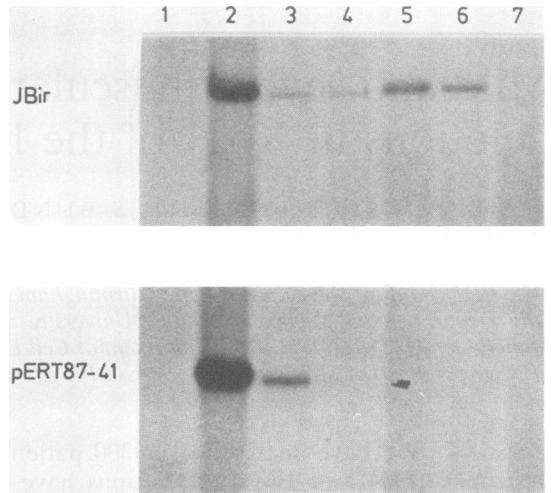

FIG 1 Southern blot analysis of DMD patients; 5 µg DNA was digested with *Pst*I. The patient samples in the tracks are as follows: (1) 324; (2) 339; (3) 1338; (4) 1339; (5) 1406; (6) 1426; (7) 1431.

positive for the latter and negative for the former, indicating deletion endpoints between these two markers. A summary of the deletions that we characterised across the DMD region is given in the table. The DMD boys have deletions ranging in size from 10 to 50 kb, as in patient 1422, to relatively large ones, as in patient 1426 (at least 300 kb). None of these boys is mentally retarded and they all show a similar clinical course. There are no significant differences between sporadic and familial cases.

The two BMD cases shown at the bottom of the table were of particular interest because they have deletions and yet are mildly affected. The pedigree corresponding to patient 324 is given in fig 2. Patient 324 is subject III.1. He showed no neurological

TABLE Summary of DNA probe deletions in patients.

	L1	JBir	41	30	15	8	1	XJ1.1	HIP25	pERT84	754
DMD											
19	◆	◆	◇	◇	◆	◆	◆	◆	◆	◆	◆
1338	◆	◆	◇	◇	◆	◆	◆	◆	◆	◆	◆
1426	◆	◆	◇	◇	◆	◆	◆	◆	◆	◆	◆
1399	◆	◆	◇	◇	◆	◆	◆	◆	◆	◆	◆
1486	◆	◆	◇	◇	◆	◆	◆	◆	◆	◆	◆
1422	◆	◆	◇	◇	◆	◆	◆	◆	◆	◆	◆
1489	◆	◆	◇	◇	◆	◆	◆	◆	◆	◆	◆
BMD											
324	◆	◇	◇	◇	◆	◆	◆	◆	◆	◆	◆
1487	◆	◆	◆	◆	◆	◆	◆	◆	◆	◆	◆

◆ Locus present. ◇ Locus absent.

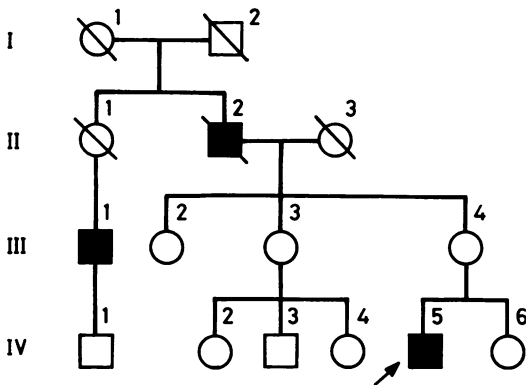

FIG 2 Pedigree of patient 324 (III.1)

symptoms until his thirties, and photographs taken before then do not reveal any signs of pseudohypertrophy of the calves. His first neuromuscular symptom came when he fell while running for a bus at the age of 35 years and three years later he saw a neurologist and was told that he had X linked muscular dystrophy. Now at the age of 61 he can walk with a stick, but only for short distances. He can manage to crawl upstairs and he is still driving a car. Examination reveals very little weakness of the arms, but severe weakness of hip flexors and extensors, and severe weakness of the quadriceps femoris. His hip abductors and adductors are only mildly affected.

Subject IV.5 complained about difficulty in rising from a squatting position and noticed that one leg occasionally gave way on walking. These symptoms were minor and he only attended a neurologist because of his family history. On examination he was found to have large quadriceps muscles and had some weakness of the pelvic girdle when rising from the floor, but no other abnormal signs. An EMG showed polyphasic potentials characteristic of a muscular dystrophy and his creatine kinase level was 3318 IU/l which confirmed the clinical diagnosis of BMD. He had no deletion of Kell, Cellano, or KPB blood groups.

Subject II.2 died at the age of 52 years after a cerebral haemorrhage. At this time he was having difficulty in walking and needed a stick.

Subject III.1 (patient 324 in the table) and IV.5 had identical deletions in our DNA analysis. The absence of JBir and pERT87-41 is shown in track 1 of fig 1. The proximal breakpoint of the deletion lies between pERT87-8 and pERT87-15, as shown in fig 3, where patient 324 shows a positive signal for the former but a negative signal for the latter. This gives a deletion in these patients of at least 110 kb.

The second BMD case shown in the table (1487)

showed a rather different clinical course. His disease progressed exactly as would be expected for DMD and he was wheelchair bound at the age of 11 years. However, further muscle weakness did not follow and he is currently running his own business from his

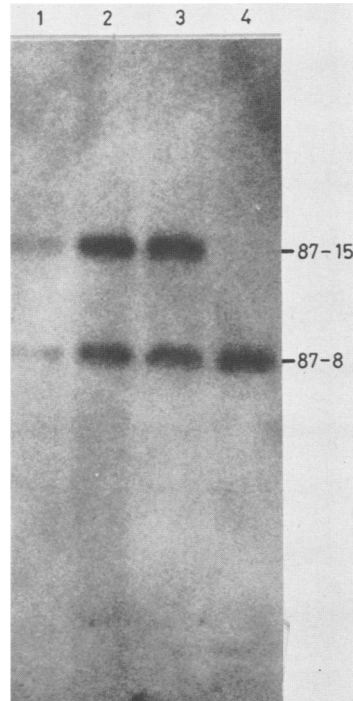

FIG 3 Southern blot analysis of the proximal breakpoint of the deletion in patient 324 (track 4). Track 1, normal male; tracks 2 and 3, DMD males. The samples were digested with *Pst*I.

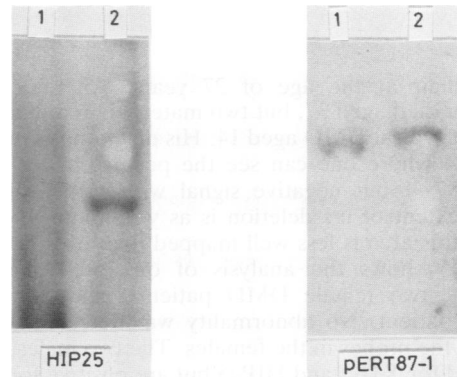

FIG 4 Southern blot analysis of patient 1487 (track 1) and non-deleted DMD male (track 2). DNA was digested with *Pst*I.

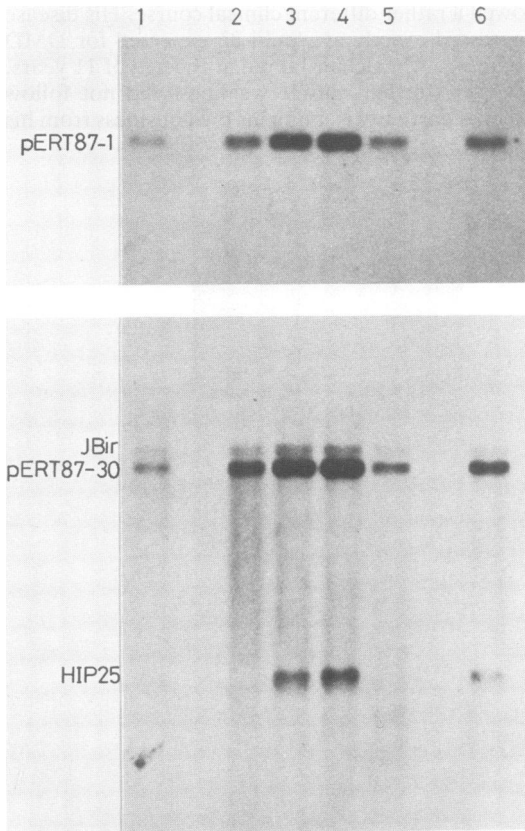

FIG 5 Southern blot analysis of DMD and BMD patients; 5 μ g DNA was digested with *Pst*I. Tracks 1 and 6, normal males; track 2, DMD patient 1517; track 3, female patient 1518; track 4, female patient 1519; track 5, BMD patient 1516.

wheelchair at the age of 27 years. An affected brother died aged 37, but two maternal great uncles died of typical DMD aged 14. His deletion is shown in fig 4 where one can see the positive signal for pERT87-1 but negative signal with HIP25. The exact extent of his deletion is as yet unknown because this area is less well mapped than pERT87.

Fig 5 shows the analysis of one male DMD patient, two female DMD patients, and a male BMD patient. No abnormality was detected with any of the probes in the females. The two males are deleted for XJ1.1 and HIP25 but are positive for all the pERT87 probes. The relationship of these two deletions with respect to one another remains to be determined.

Discussion

These data show that the extent of deletions found in patients is not related in a simple manner to the severity of the phenotype. Small deletions can lead to both severe DMD and mild BMD. This has been noted by others.²²⁻²⁵ This suggests that it is possible to remove parts of the gene such that if the processing of the transcript remains in a phase for translation a functional protein can be produced. This protein of course will not be as efficient in its action as the normal gene product. In cases of severe DMD the deletion must severely affect the integrity of the protein product and in some cases it might completely inhibit the production of protein. The exact mechanisms of these processes must await the determination of the breakpoints and the exons of the gene involved in the deletions.

One of the striking results reported here is the clinical presentation of patient 324 who possesses a deletion of at least 110 kb and yet is very mildly affected. From the knowledge of the exons present in this region of the gene, this patient must be missing at least four coding regions of the protein. Thus he must be able to cope with a truncated protein or have some way of compensating very efficiently for the lack of production of the DMD gene product. We are currently using cDNA clones to map and sequence his deletion endpoints.

The identification of mild patients who may be producing smaller proteins than normal males may allow us to characterise the smallest possible functional unit of this unusual protein. In this way we hope to be able to gain some insights into the disease pathology and possible therapies for this disorder in the future.

We would like to thank Drs Kurnath, Schieber, Spiegler, Sommer, Emery, Dubowitz, Bobrow, and Fischbeck for patient blood samples. We also thank Dr Adrian Williams for information on IV.5 from the family in fig 2. We are grateful to the Medical Research Council, the Muscular Dystrophy Association of America, and the Muscular Dystrophy Group of Great Britain and Northern Ireland for financial support. AS would like to thank the Wellcome Trust for financial support. TJS is a recipient of a SERC Instant Award.

References

- Gardner-Medwin D. Clinical features of classification of the muscular dystrophies. *Br Med Bull* 1980;36:109-15.
- Elejalde BR, Elejalde MM. Phenotypic manifestations of X-autosome translocations. In: Sandberg AA, ed. *Cytogenetics of the X chromosome*. New York: Alan R Liss, 1983:225-44.
- Boyd Y, Buckle VJ. Cytogenetic heterogeneity of translocations associated with Duchenne muscular dystrophy. *Clin Genet* 1986;29:108-15.

- ⁴ Murray JM, Davies KE, Harper PS, *et al*. Linkage relationship of a cloned DNA sequence on the short arm of the X chromosome to Duchenne muscular dystrophy. *Nature* 1982;**300**:69–71.
- ⁵ Davies KE, Pearson PL, Harper PS, *et al*. Linkage analysis of the two cloned DNA sequences flanking the Duchenne muscular dystrophy locus on the short arm of the human X chromosome. *Nucleic Acids Res* 1983;**11**:2303–12.
- ⁶ Aldridge J, Kunkel L, Bruns G, *et al*. A strategy for construction of highly polymorphic DNA haplotypes in specific human chromosomal regions: application to linkage analysis of X chromosome specific diseases such as Duchenne muscular dystrophy. *Ital J Neurol Sci* 1984;**3**:39–46.
- ⁷ Bakker E, Hofker MH, Goorl N, *et al*. Prenatal diagnosis and carrier detection of Duchenne muscular dystrophy with closely linked RFLPs. *Lancet* 1985;**i**:655–8.
- ⁸ Kunkel LM, Monaco AP, Middlesworth W, *et al*. Specific cloning of DNA fragments absent from the DNA of a male patient with an X chromosome deletion. *Proc Natl Acad Sci USA* 1985;**82**:4778–82.
- ⁹ Kunkel LM, Hejtmanck JF, Caskey CT, *et al*. Analysis of deletions in DNA from patients with Becker and Duchenne muscular dystrophy. *Nature* 1986;**322**:73–7.
- ¹⁰ Monaco AP, Neve RL, Colletti-Feneer C, *et al*. Isolation of candidate cDNAs for portions of the Duchenne muscular dystrophy gene. *Nature* 1986;**323**:646–50.
- ¹¹ Wood DS, Zeviani M, Prellc A, *et al*. Is nebulin the defective gene product in Duchenne muscular dystrophy. *N Engl J Med* 1987;**316**:107–8.
- ¹² Ray PN, Belfall B, Duff C, *et al*. Cloning of the breakpoint of an X:21 translocation associated with Duchenne muscular dystrophy. *Nature* 1985;**318**:672–5.
- ¹³ Kenwick S, Patterson MN, Speer A, *et al*. Molecular analysis of the Duchenne muscular dystrophy region using pulsed-field gel electrophoresis. *Cell* 1987;**48**:351–7.
- ¹⁴ Burmeister M, Lehrach H. Long range restriction map around the Duchenne muscular dystrophy gene using pulsed-field gel electrophoresis. *Nature* 1986;**324**:582–5.
- ¹⁵ van Ommen GJB, Verkerk JMH, Hofker MH, *et al*. A physical map of 4 million bp around the Duchenne muscular dystrophy gene on the human X chromosome. *Cell* 1986;**47**:499–504.
- ¹⁶ Smith TJ, Wilson L, Kenwick SJ, *et al*. Isolation of a conserved sequence deleted in some DMD patients. *Nucleic Acids Res* 1987;**15**:2167–74.
- ¹⁷ Kunkel LM, Smith KD, Boyer SH, *et al*. Analysis of human Y chromosome specific reiterated DNA in chromosome variants. *Proc Natl Acad Sci USA* 1977;**74**:1245–9.
- ¹⁸ Southern EM. Detection of specific sequences among DNA fragments separated by gel electrophoresis. *J Mol Biol* 1975;**98**:503–17.
- ¹⁹ Monaco AP, Bertelson CJ, Colletti-Feneer C, Kunkel LM. Localisation and cloning of deletion breakpoints in Xp21 involved in muscular dystrophy. *Hum Genet* 1987;**75**:221–7.
- ²⁰ Goodfellow PN, Davies KE, Ropers HH, Report of the committee on the genetic constitution of the X and Y chromosomes. *Cytogenet Cell Genet* 1985;**40**:296–352.
- ²¹ Paulsen K, Forrest S, Scherer G, *et al*. Regional localisation of X chromosome short arm probes. *Hum Genet* 1986;**74**:155–9.
- ²² Monaco AP, Bertelson CJ, Middlesworth W, *et al*. Detection of deletions spanning the Duchenne muscular dystrophy locus using a tightly linked DNA segment. *Nature* 1985;**316**:842–5.
- ²³ Thomas NST, Ray PN, Worton RG, Harper PS. Molecular deletion analysis in Duchenne muscular dystrophy. *J Med Genet* 1986;**23**:509–15.
- ²⁴ Hart K, Cole C, Walker A, *et al*. The screening of Duchenne muscular dystrophy patients for submicroscopic deletions. *J Med Genet* 1986;**23**:516–20.
- ²⁵ Monaco AP, Kunkel LM. A giant locus for the Duchenne and Becker muscular dystrophy gene. *Trends Genet* 1987;**3**:33–7

Correspondence and requests for reprints to Dr K E Davies, Nuffield Department of Clinical Medicine, John Radcliffe Hospital, Headington, Oxford OX3 9DU.