

# Identification of the haplotype pattern associated with the mutant PKU allele in the Gypsy population of Wales

L A TYFIELD\*†, A L MEREDITH\*, M J OSBORN†,  
AND P S HARPER\*

*From \*the Institute of Medical Genetics, University of Wales College of Medicine, Heath Park, Cardiff; and †Section of Molecular Genetics, Department of Biochemistry, Southmead Hospital, Bristol.*

**SUMMARY** Using the full length cDNA probe, the RFLP haplotype patterns at the phenylalanine hydroxylase locus have been studied in the extensive and highly consanguineous Welsh Gypsy population. The pattern associated with the mutant PKU allele is identical to haplotype 4 in the northern European population. Two children with classical PKU are homozygous for this haplotype. We have tracked the mutant allele through four generations to a great grandfather who died 22 years ago. Both affected children almost certainly have inherited a double dose of the same mutant PKU allele from one common ancestor. It should be possible to identify the specific mutation that is associated with haplotype 4 which results in the more serious form of PKU.

Phenylketonuria (PKU) is the commonest inborn error of amino acid metabolism. The incidence among Caucasians is around 1 in 10 000, but there are large differences in its frequency between populations, varying from 1 in 32 000 in Sweden<sup>1</sup> to 1 in 4500 in Northern Ireland.<sup>2</sup>

PKU is frequent in the Gypsy population in Wales. In a study reported by Williams and Harper<sup>3</sup> the incidence in this highly consanguineous group was estimated to be 1 in 40 compared to 1 in 16 000 in Wales as a whole and about one in four persons was expected to be a carrier of the mutant allele.

Because of the large number of consanguineous marriages in this population, identification of carriers of the PKU gene is important so that couples are aware of their risks of producing affected children. The biochemical procedures required to do this, however, are cumbersome, require a good deal of cooperation from the subjects, and can often be unreliable. The tests rely either on a phenylalanine load to challenge the reduced capacity for phenylalanine hydroxylation in the heterozygote or on the measurement of the steady state plasma concentration of phenylalanine and tyrosine under carefully controlled conditions. In a large, migrant family where more than 100 persons could be studied either

of these biochemical approaches to determining carrier status would be impracticable.

Recently, a full length cDNA probe for the phenylalanine hydroxylase locus has been isolated and cloned.<sup>4</sup> With this probe and several restriction enzymes<sup>5</sup> haplotype patterns of mutant and non-mutant alleles can now be defined in families in which PKU is known to occur,<sup>6</sup> and where families are informative biochemical testing for carrier status is no longer essential. Using this approach we have defined the haplotype pattern of the mutant PKU allele in the Gypsy population in Wales and we followed the inheritance of the PKU allele from one affected child through four generations to a great grandfather who died 22 years ago.

## Methods

### DIAGNOSING PKU

All affected children in the study were diagnosed in the neonatal period using thin layer chromatography of heparinised blood samples. The diagnosis was confirmed by fluorimetric measurement of plasma phenylalanine. A diagnosis of classical phenylketonuria was based on blood phenylalanine concentrations greater than 1200  $\mu\text{mol/l}$  and the appearance of secondary metabolites in the urine.

### ESTABLISHING HAPLOTYPE PATTERNS AT THE PAH LOCUS

Leucocyte DNA was digested with the following

restriction enzymes: *Bgl*III, *Pvu*II, *Xmn*I, *Eco*RI, *Msp*I, *Eco*RV, and *Hind*III. DNA fragments were separated in 0.8% agarose, Southern blotted, and hybridised with the <sup>32</sup>P oligolabelled cDNA probe PAH 247, kindly supplied by Dr Savio Woo, Houston, Texas. These seven restriction enzymes highlight nine polymorphic sites at the PAH locus.<sup>5,6</sup> The composite profile of the presence or absence of the different polymorphic sites defines the haplotype pattern of the allele.

Haplotype patterns could be defined from key family members who were homozygous for all restriction fragment length polymorphisms (RFLPs) or heterozygous at only one polymorphic site. Appropriate patterns were then assigned to one chromosome of each parent or offspring and the pattern on the second chromosome was derived from the remaining alleles of each RFLP. Numbers assigned to the haplotypes were the same as those used by Chakraborty *et al.*<sup>7</sup>

## Results

### BIOCHEMICAL DIAGNOSIS OF PKU

The three affected children studied from one branch of the family were classified as having classical PKU on the basis of blood phenylalanine concentrations greater than 1200 µmol/l at diagnosis.

### RELATIONSHIP BETWEEN AFFECTED CHILDREN

The south Wales Gypsy kindred forms one large

inbred pedigree which has been traced back five generations<sup>7</sup> and consists of several hundred persons; we have obtained DNA samples from subjects spanning four generations. For the purpose of clarity we present a very condensed pedigree which highlights the interrelationship between the affected children (fig 1). Affected subjects and obligate heterozygotes are shown. The child V.1 is the product of a first cousin marriage between IV.1 and IV.2. His grandmother III.2 is a first cousin to his other grandmother III.4 who is also an aunt of another affected subject, IV.3. Affected subject IV.3 is again the product of a first cousin marriage between III.5 and III.6, her father III.5 being a half brother of the grandmother of the third affected subject V.2. Fig 1 shows that three brothers of generation II have direct descendants with PKU. Only two affected children are alive. V.2 died in an accident at the age of three years.

### HAPLOTYPE PATTERNS AT THE PAH LOCUS

In this family, the affected subjects are homozygous for haplotype 4; hence the chromosome carrying the PKU mutation is associated with the haplotype (table). Both parents of V.1 are heterozygous for haplotypes 4 and 1. This makes it possible to distinguish between mutant and normal chromosomes in this branch of the family. Any sib of V.1 who has haplotype 4 will carry the PKU mutation on that chromosome and hence is an asymptomatic carrier of the disease. Haplotype 4, however, is also

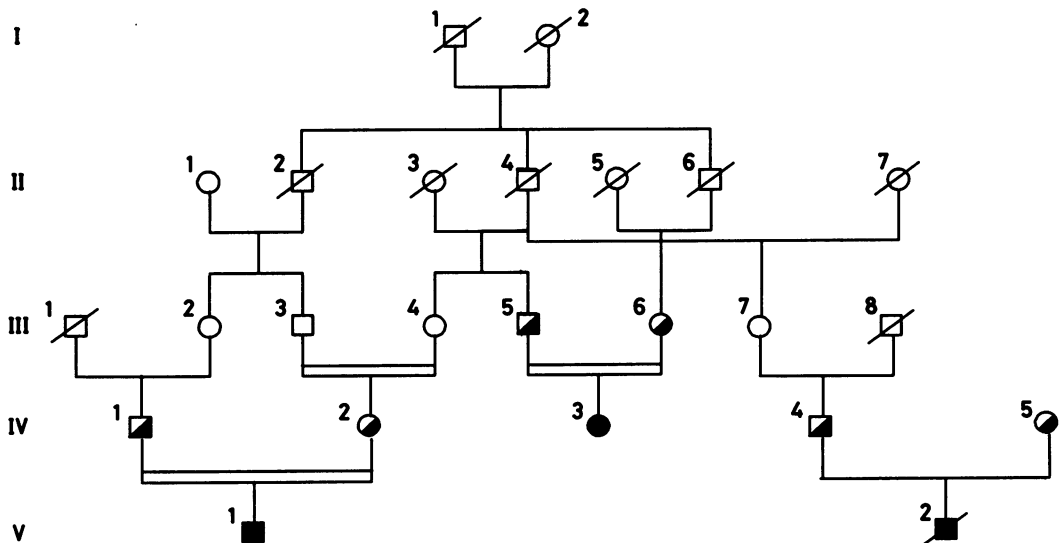

FIG 1 A very condensed pedigree of the Gypsy population of Wales showing the interrelationship between the affected children. Filled squares or circles are affected homozygotes and half filled circles or squares are obligate heterozygotes.

TABLE Haplotype patterns at the phenylalanine hydroxylase locus in key family members.

Family member	Biochemical phenotype	Relationship to affected child	Haplotype
V.1	PKU		4/4
IV.1	Heterozygote	Father of V.1	4/1
IV.2	Heterozygote	Mother of V.1	4/1
IV.3	PKU		4/4
III.5	Heterozygote	Father of IV.3	4/4
III.6	Heterozygote	Mother of IV.3	4/4

associated with a non-mutant chromosome since both parents of the affected child IV.3 are homozygous 4/4. All sibs of IV.3 are also homozygous for haplotype 4 and therefore it is not possible to establish which are heterozygotes for the mutant gene. None has PKU clinically or biochemically.

TRACKING THE MUTANT ALLELE THROUGH SUCCESSIVE GENERATIONS

Fig 2 shows how the PKU gene was tracked from the affected child V.1 to the great grandparents. Each parent carries a PKU gene associated with haplotype 4 and a normal gene associated with haplotype 1. In generation III, because the maternal grandfather is homozygous for haplotype 1, the mother of

the affected child must have inherited the PKU gene associated with haplotype 4 from her mother who has haplotype 4 and 1.

The deduction is slightly more complex for the father of V.1 since only the paternal grandmother is alive. In order to determine whether haplotype 4 was inherited from the grandmother or her dead husband III.1 it was necessary to haplotype this woman's other 10 children to infer the genotype of her husband. Assuming paternity is true we can infer that the grandfather's haplotype was 2/1 and therefore the PKU gene must have been inherited from the grandmother III.2 who is haplotype 4/1. We were able to type the great grandmother II.1 of affected subject V.1. Her haplotype was 5/1 confirming that haplotype 4 together with the PKU mutation had originated in the great grandfather, who has two brothers with affected PKU descendants, each of whom had a chromosome with haplotype 4.

Discussion

The availability of a cDNA probe for the phenylalanine hydroxylase locus has made it possible to define the haplotype patterns of mutant and normal chromosomes in families in which PKU is known to

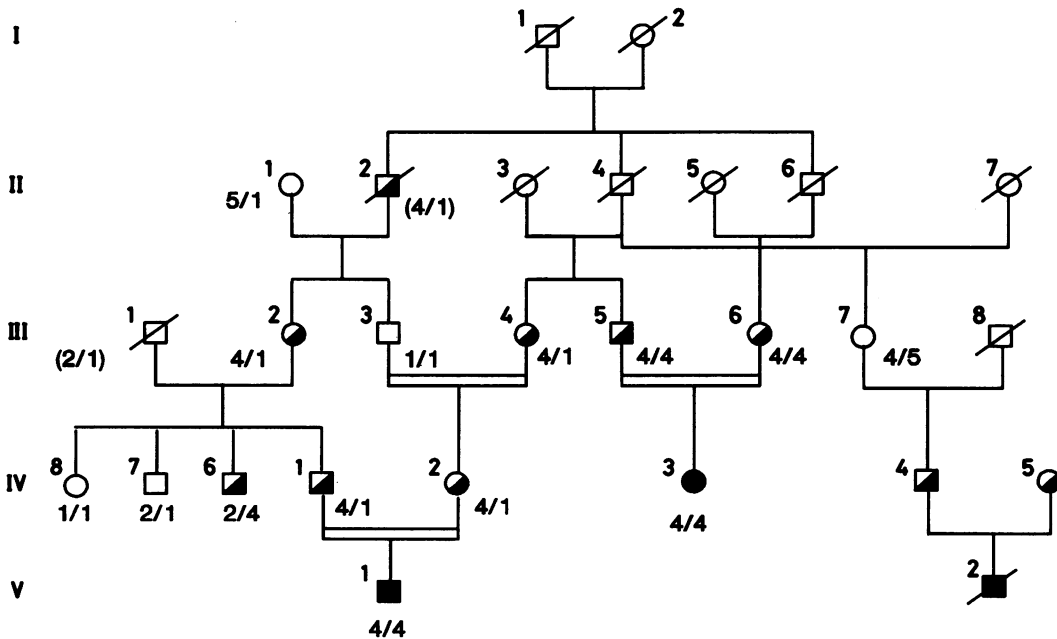

FIG 2 Showing how the mutant PKU allele was tracked from the affected child V.1 to the great grandfather II.2. The mutant allele is associated with haplotype 4 and so any ancestor of V.1 who carries one haplotype 4 allele is known to be a carrier. Haplotypes in brackets are inferred from those of the other family members.

occur. In several studies of PKU in different European populations,<sup>8-12</sup> it has been shown that a large proportion of mutant alleles are associated with four haplotypes numbered 1 to 4. However, there are some differences between the populations in the frequency of RFLP haplotypes in linkage with the PKU allele. In Denmark, for example, most of the PKU alleles (38%) are associated with haplotype 3,<sup>8</sup> whereas in the German population the fewest mutant alleles are associated with this haplotype.<sup>9, 10</sup> In France, mutant haplotype 1 is the most frequent, accounting for 31% of the mutant alleles.<sup>11</sup>

Two specific mutations which are in linkage disequilibrium with haplotypes 2 and 3 in the Danish population have been defined, a point mutation at exon 12 occurring on haplotype 2<sup>13</sup> and a splice mutation at the intron/exon junction of exon 12 occurring on haplotype 3.<sup>14</sup> Both mutations lead to a complete loss in enzyme activity and so patients who had any combination of mutant haplotypes 2 and 3 invariably had a more severe form of the disorder.<sup>8</sup> This tight linkage between a mutant haplotype 3 allele and the splicing mutation also exists in the German and French populations.<sup>9, 10</sup> However, it appears that with each of the other common haplotypes more than one mutation may account for the reduction in or absence of enzyme activity. This was originally suggested in relation to haplotype 4 in the Danish study<sup>8</sup> and was shown to be the case in relation to haplotype 2 in the French study.<sup>11</sup> A third mutation which occurred in association with haplotype 10 has also been determined and this was a point mutation in exon 9.<sup>15</sup>

In the south Wales Gypsy kindred, the PKU gene occurs in association with haplotype 4. All affected children have been classified as having classical PKU because of blood phenylalanine concentrations above 1200 µmol/l and so it is likely that the specific mutation results in virtually a complete loss in enzyme activity.

In tracking the mutant chromosome through several generations, the study has highlighted in particular that a high degree of consanguinity increased the homozygous state of PKU, which has an autosomal recessive mode of inheritance. The two affected children in one branch of the family almost certainly have a double dose of the same mutation which was inherited from one common ancestor. It has been possible to track this mutation from one affected child through four generations to his great grandfather II.2 who died 22 years ago. The second PKU chromosome was probably inherited from this man's brother via the maternal grandmother. This brother is probably a carrier of the same mutation associated with haplotype 4 as he had two children (who are known carriers) by one

marriage and his other daughter by a second marriage is the grandmother of the third affected child. All have haplotype 4 on at least one chromosome. A third brother of generation II probably carried this same mutation as he is also the grandfather of an affected girl, IV.3. These three men probably inherited the mutant allele from their mother, a non-Gypsy woman who had two marriages with Gypsies. In another extensive branch of the family there are four more children who have PKU<sup>3</sup> and they are all the descendants of her second union with a Gypsy man.

While dietary treatment and population screening for PKU have greatly reduced the morbidity previously associated with this disorder, accurate knowledge of carrier status is still of importance to family members, particularly where the gene is at high frequency as in this population. The problems encountered with mobility and lack of dietary compliance, as well as the unacceptability of prenatal diagnosis, are additional factors in the Welsh Gypsy population. This makes it important to establish which branches of the kindred are at risk of having an affected child.

Work is currently in progress to analyse the molecular defect in more detail. While we have no evidence that a specific PKU mutation is unique to the Welsh or other Gypsy populations, availability of a specific test would be helpful for family members in whom DNA polymorphisms are uninformative or where the family structure is incomplete.

We are grateful to Dr Mair Williams for making information on the kindred available. MJO is supported by a research grant from the South Western Regional Health Authority.

#### References

- 1 Tourian A, Sidbury JB. Phenylketonuria and hyperphenylalaninaemia. In: Stanbury JB, Wyngaarden JB, Fredrickson DS, Goldstein JL, Brown MS, eds. *The metabolic basis of inherited disease*. New York: McGraw-Hill, 1983:270-86.
- 2 Smith, I, Wolff OH. *MRC/DHSS phenylketonuria register appendix to newsletter 9. Screening data for UK 1979-83*, 1984:2.
- 3 Williams EM, Harper PS. Genetic study of Welsh Gypsies. *J Med Genet* 1977;14:172-6.
- 4 Kwok CM, Ledley FD, DiLella AG, Robson KJH, Woo SLC. Nucleotide sequence of a full-length complementary DNA clone and amino acid sequence of human phenylalanine hydroxylase. *Biochemistry* 1985;24:556-61.
- 5 DiLella AG, Kwok SCM, Ledley FD, Marvit J, Woo SLC. Molecular structure and polymorphic map of the human phenylalanine hydroxylase gene. *Biochemistry* 1986;25:743-9.
- 6 Lidsky AS, Ledley FD, DiLella AG, et al. Extensive restriction site polymorphism at the human phenylalanine hydroxylase locus and application in prenatal diagnosis of phenylketonuria. *Am J Hum Genet* 1985;37:619-34.

- <sup>7</sup> Chakraborty R, Lidsky AS, Daiger SP, *et al.* Polymorphic DNA haplotypes at the human phenylalanine hydroxylase locus and their relationship with phenylketonuria. *Hum Genet* 1987;**76**:40–6.
- <sup>8</sup> Guttler F, Ledley FD, Lidsky AS, DiLella AG, Sullivan SE, Woo SLC. Correlation between polymorphic DNA haplotypes at phenylalanine hydroxylase locus and clinical phenotypes of phenylketonuria. *J Pediatr* 1987;**110**:68–71.
- <sup>9</sup> Aulchla-Scholz C, Vorgerd M, Sautter E, *et al.* Phenylketonuria: distribution of DNA diagnostic patterns in German families. *Hum Genet* 1988;**78**:353–5.
- <sup>10</sup> Lichter-Konecki U, Schlotter M, Konecki DS, Labeit S, Woo SLC, Trefz FK. Linkage disequilibrium between mutation and RFLP haplotype at the phenylalanine hydroxylase locus in the German population. *Hum Genet* 1988;**78**:347–52.
- <sup>11</sup> Rey F, Berthelon M, Caillaud C, *et al.* Clinical and molecular heterogeneity of phenylalanine hydroxylase deficiencies in France. *Am J Hum Genet* 1988;**43**:914–21.
- <sup>12</sup> Riess O, Michel A, Speer A, Meiske W, Cobet G, Coutelle C. Linkage disequilibrium between RFLP haplotype 2 and the affected PAH allele in PKU families from the Berlin area of the German Democratic Republic. *Hum Genet* 1988;**78**:343–6.
- <sup>13</sup> DiLella AG, Marvit J, Lidsky AS, Guttler F, Woo SLC. Tight linkage between a splicing mutation and a specific DNA haplotype in phenylketonuria. *Nature* 1986;**322**:799–803.
- <sup>14</sup> DiLella AG, Marvit J, Brayton K, Woo SLC. An amino-acid substitution involved in phenylketonuria is in linkage disequilibrium with DNA haplotype 2. *Nature* 1987;**327**:333–6.
- <sup>15</sup> Lichter-Konecki U, Konecki DS, DiLella AG, *et al.* Phenylalanine hydroxylase deficiency caused by a single base substitution in an exon of the human phenylalanine hydroxylase gene. *Biochemistry* 1988;**27**:2881–5.

Correspondence to Professor P S Harper, Institute of Medical Genetics, University of Wales College of Medicine, Heath Park, Cardiff CF4 4XN.