

## Clinical reinvestigation and linkage analysis in the family with Episkopi blindness (Norrie disease)

G Wolff, A Mayerová, T F Wienker, P Atalianis, P Ioannou, M Warburg

### Abstract

We present the results of a clinical and genetic reinvestigation of the Cypriot family affected by an X chromosomally inherited eye disease originally published by Taylor *et al*, who coined the term Episkopi blindness. The pedigree was extended to 160 members, including 16 affected males out of 48 males at risk for the disease, most of whom were seen by one of us (PA). Affected males are blind with no associated symptoms and apparently are not mentally retarded. Thirty-nine family members agreed to blood sampling for genetic investigations. RFLP analysis was performed using probes from the region known to be deleted in some Norrie patients and polymorphic markers (*DXS77*, *DXS7*, *MAOA*, *DXS255*) from the proximal short arm of the X chromosome. There was no deletion for any of the probes in the affected males. Linkage analysis yielded positive lod scores for all informative markers ( $\hat{Z}$  (*DXS255*,  $\theta=0$ ) = 6.54,  $\hat{Z}$  (*MAOA*,  $\theta=0$ ) = 2.23,  $\hat{Z}$  (*DXS7*,  $\theta=0$ ) = 2.13). Thus, the conclusion that Episkopi blindness and Norrie disease (NDP, MIM \*310600) are the same entity based on clinical evidence is now reinforced by gene mapping.

(J Med Genet 1992;29:816-9)

Norrie disease (ND) is an X linked recessive disorder characterised by blindness caused by the early development of retinal dysplasia, vascular proliferation (pseudoglioma), and ocular phthisis<sup>1</sup> (MIM \*310600). Over 300 cases have been described, about one third of which have additional symptoms such as sensorineural hearing loss, mental retardation, or psychotic behaviour.<sup>2-4</sup> Close linkage has been shown between the disease locus (*NDP*) and *DXS7* at Xp11.3 defined by probe L1.28<sup>5-8</sup> bringing the compiled lod score for linkage between *NDP* and *DXS7* to 6.51 at  $\theta=0.00$ .<sup>8</sup> Recombination events between these two loci have been reported by Ngo *et al*.<sup>9,10</sup>

Several patients with Norrie disease have been reported who carry microdeletions encompassing *DXS7*.<sup>11-14</sup> In the patient of Donnai *et al*,<sup>13</sup> the deletion included *DXS228* defined by probe 1aA6. In the patients of Gal *et al*<sup>12</sup> and de la Chapelle *et al*,<sup>11</sup> the *MAOA* and *MAOB* genes were also shown to be deleted.<sup>15,16</sup> Sims *et al*<sup>17</sup> reported another deletion patient who uniquely retained the *DSX7*

locus while being deleted for *MAOA* and *MAOB*. In addition to the ophthalmic features the clinical picture in the deletion cases comprised one or more symptoms such as severe mental retardation, hypotonia, hyperreflexia, microcephaly, cryptorchidism, and failure to thrive.<sup>13,15</sup>

Taylor *et al*<sup>18</sup> reported a six generation Greek Cypriot family with an apparently X linked blindness living in Episkopi in Cyprus, the disease therefore being popularly known as Episkopi blindness. This condition was thought to be another example of Norrie disease on clinical and genetic grounds by Warburg.<sup>1</sup> The family was restudied clinically by Merin *et al*<sup>19</sup> in 1972.

We performed a clinical reinvestigation of the family and linkage analysis with DNA markers from the short arm of the X chromosome to test the identity of Episkopi blindness and Norrie disease.

### Materials and methods

#### FAMILY AND PATIENTS

The family is personally known to one of us (PA). This allowed us to take the family history and to extend the pedigree to 160 members including 16 affected males out of 48 males at risk (fig 1). Of the living affected males and obligate female carriers all but one each (VI.47, V.17) were seen. Unfortunately, neither the male patients nor the female obligate carriers were willing to see an ophthalmologist for thorough ophthalmoscopic examination. Thirty-nine family members (including one husband of a potentially heterozygous woman) agreed to blood sampling for genetic analysis.

#### PROBES

The following probes were used in this study: L1.28 (*TaqI*) defining *DXS7*,<sup>20</sup> pX59 (*EcoRV*) defining *DXS77*,<sup>21</sup> M27 $\beta$  (*EcoRI*) defining *DXS255*,<sup>22</sup> and MAO-A (*EcoRV*) defining *MAOA*.<sup>23</sup>

#### METHODS

Chromosomal DNA from peripheral blood cells were isolated using standard methods. After digestion with restriction enzymes according to the manufacturer's specifications and separation on 0.8% agarose gels, the DNA was blotted onto Hybond N+ (Amersham) membranes and hybridised to a probe radio-

Institut für  
Humangenetik,  
Breisacher Strasse 33,  
D-7800 Freiburg,  
Germany.  
G Wolff  
A Mayerová  
T F Wienker  
P Atalianis

The Cyprus Institute  
of Neurology and  
Genetics, Nicosia,  
Cyprus.  
P Ioannou

The Copenhagen Eye  
Clinic for the  
Mentally Retarded,  
Gentofte, Denmark.  
M Warburg

Correspondence to  
Dr Wolff.

Received 17 March 1992.  
Revised version accepted  
9 April 1992.

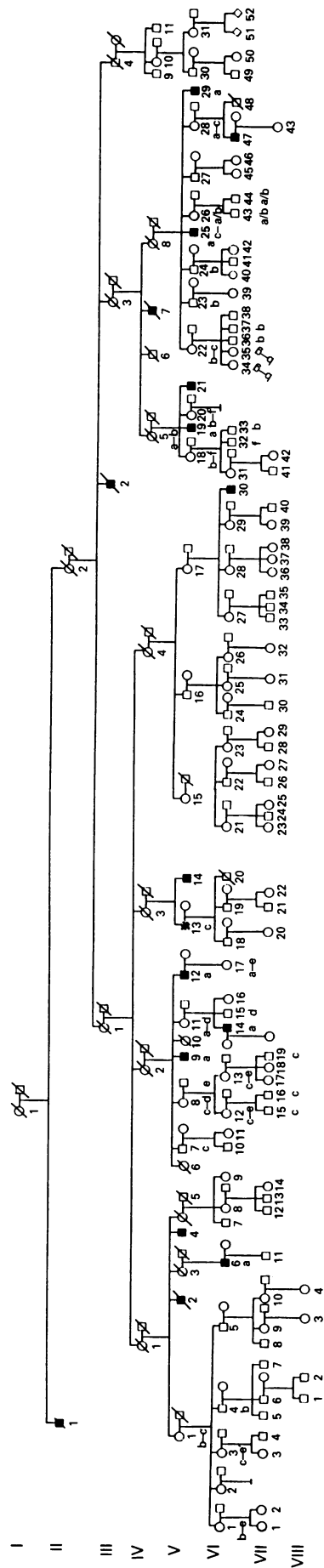

Figure 1 Pedigree of the family. a-f: haplotypes of NDP linked polymorphic DNA markers as shown in table 2.

actively oligolabelled by the method of Feinberg and Vogelstein.<sup>24</sup> Prehybridisation and hybridisation were performed at 65°C in 0.5 mol/l sodium phosphate, 0.001 mol/l EDTA, and 7% sodium dodecyl sulphate. Blots were autoradiographed after being washed with 0.02 mol/l sodium phosphate and 1% sodium dodecyl sulphate at 65°C.

Lod scores were calculated using the LIPED program,<sup>25</sup> and multipoint linkage analysis was performed using the LINKMAP program, version 5.10, kindly provided by J Ott (fig 2).

**Results and discussion**

The pedigree, compared with that published by Taylor *et al*,<sup>18</sup> could be extended by one generation and 66 family members (fig 1).

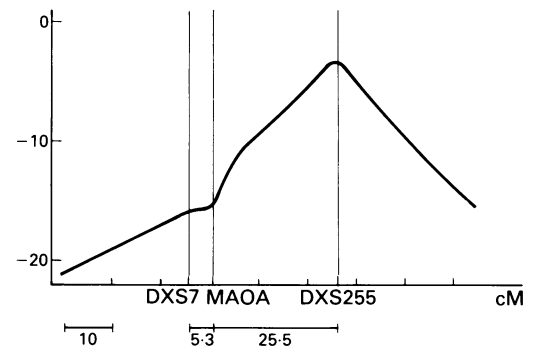

Figure 2 Multipoint linkage analysis using the LINKMAP program (version 5.1, provided by J Ott 1991). The vertical axis gives the location scores.<sup>26</sup> Note the scale factor and offset. The horizontal axis is related to the marker map according to Mahtani *et al*.<sup>27</sup> Locus DXS77 is not shown, because there is no significant contribution (table 3). The unusual shape of the location score curve results from the absence of recombination events in the Episkopi pedigree. Absence of interference is assumed and hence Haldane's mapping function is used.

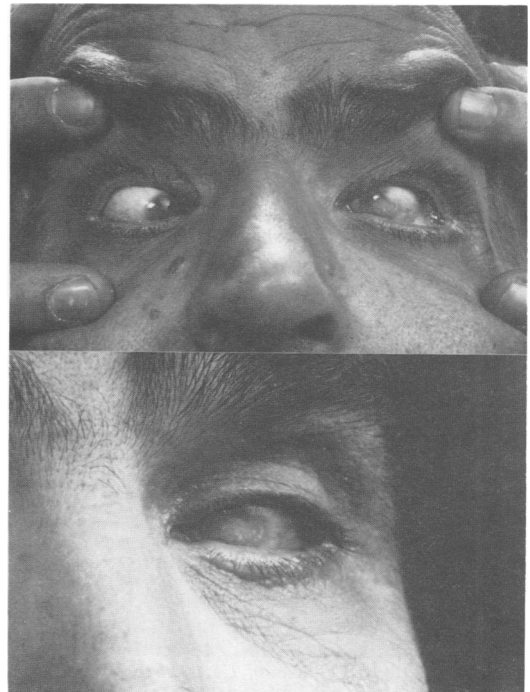

Figure 3 Clinical features of V.9 at the age of 55 years.

Ophthalmic symptoms in the affected are shown in table 1. All suffer from congenital blindness apart from three, who had some vision or light perception up to 3, 7, and 13 years of age. V.13 is blind after an accident with an insecticide spray at the age of 55. The clinical features of one of the patients (V.9) is shown in fig 3. A CT scan in another affected subject, who had some vision in the right eye and perception of light in the left up to 7 years of age, is shown in fig 4. This clearly shows the

variability of expression of the gene defect. At the time of our investigation none of the living patients who were seen by us had mental or hearing defects, and none had any of the additional symptoms frequently observed in Norrie disease, especially in patients with microdeletions. Accordingly we did not find a microdeletion with the probes X.59, L1.28, or MAO-A which are known to detect deletions in some of the patients with Norrie disease. A DNA probe 500 kb proximal to

Table 1 Clinical data of 11 patients.

Pedigree No	Age at the time of this study	Side	Small eye	Diffuse corneal opacity	Band shaped corneal opacity	Cataract	Retrolental opacity	Amaurosis (V = vision, PL = perception of light)
V.4	72	R	-	+	+			+
		L	-	+	+			+
V.9	55	R	+	+	+			+
		L	+	+	-			+
V.12	54	R	+	+	+			PL (13y) V (9y)
		L	+	+	+			+
V.19	45	R	+	+	+			+
		L	+	+	+			+
V.21	41	R	-	-	-	+		+
		L	-	-	-		+	PL (6y)
V.25	63	R	+	+	+			+
		L	+	+	+			+
V.29	53	R	+	+	+			+
		L	+	+	+			+
VI.6	53	R	-	+	+			+
		L	-	+	+			+
VI.14	35	R	+	+	-		**	V (7y)
		L	+	+	-		**	PL (7y)
VI.30	41	R	+	+	+			+
		L	+	+	+			+
VI.47†	42	R	+	+	-			+
		L	-	-	-	+		+

\*Seen on ocular scans.

†Information quoted from Taylor *et al.*<sup>18</sup>

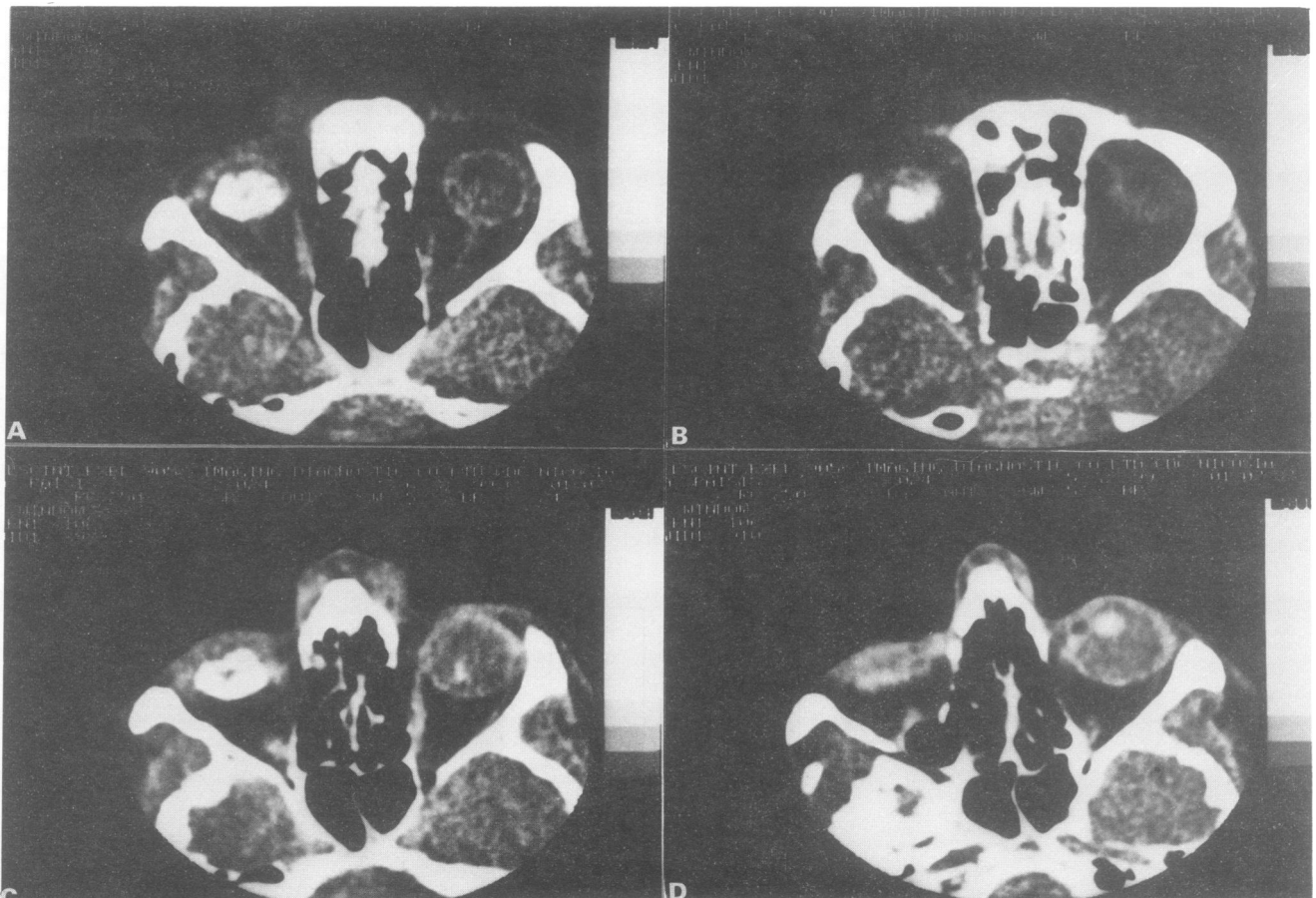

Figure 4 Cranial CT scan of VI.14 at the age of 35 years. He had some vision on the right up to 7 years and perception of light by the age of 7 on the left. Note on the left a small osseous orbit, a small globe with squamous calcification in a ring-like configuration, and a central, non-calcified area (A), and diminution of the optic nerve (B). On the right, spotty calcifications in the posterior segment of the eye (C) and a slight hyperdensity in the medial part of the lens (D) can be seen.

Table 2 Marker haplotypes for four NDP linked loci segregating in the family.

Locus	Probe	Enzyme	Haplotypes						
			a	b	c	d	e	f	g
<i>DXS77</i>	X59	<i>EcoRV</i>	1	1	1	1	1	1	2
<i>DXS7</i>	L1.28	<i>TaqI</i>	1	2	1	1	1	2	1
<i>MAOA</i>	MAO-A	<i>EcoRV</i>	1	2	1	1	1	2	1
<i>DXS255</i>	M27 $\beta$	<i>EcoRI</i>	1	2	3	4	2	4	3

Table 3 Lod scores of main locus and marker data, calculated using the LIPED program.

Locus	<i>v</i>	Locus	$\theta$						$\hat{\theta}$	Z( $\hat{\theta}$ )
			0.00	0.05	0.10	0.20	0.30	0.40		
<i>NDP</i>	<i>v</i>	<i>DXS7</i>	2.13	1.97	1.79	1.39	0.95	0.45	0.00	2.129
		<i>DXS77</i>	0.04	0.03	0.02	0.01	0.00	0.00	0.00	0.041
		<i>MAOA</i>	2.23	2.05	1.86	1.44	0.98	0.47	0.00	2.233
<i>DXS7</i>	<i>v</i>	<i>DXS255</i>	6.54	5.97	5.37	4.11	2.76	1.36	0.00	6.537
		<i>MAOA</i>	5.05	4.61	4.15	3.19	2.14	1.01	0.00	5.049
		<i>DXS255</i>	— $\infty$	3.05	2.96	2.43	1.70	0.84	0.057	3.053
<i>DXS255</i>	<i>v</i>	<i>MAOA</i>	— $\infty$	3.13	3.03	2.48	1.74	0.87	0.056	3.135

L1.28 also failed to detect a deletion in one of the affected males (T Meitinger, personal communication).

Results of DNA haplotyping are shown in fig 1 and table 2. As can be seen the phenotype 'Episkopi blindness' cosegregates with the 'a' haplotype. There is only one crossover between *DXS255* and *MAOA* in V.26, indicated as a/b haplotype. Linkage analysis yielded positive lod scores for all markers segregating in an informative fashion (table 3). Thus, the identity of Episkopi blindness and Norrie disease is supported by gene mapping. *DXS255* (probe M27 $\beta$ ) gives the highest lod score (6.54 at  $\theta=0.00$ ) only because it is the most informative marker and there are no recombinations between *NDP* and any of the markers used. Clearly, the Norrie disease locus must be located in close proximity to the *MAOA* locus.<sup>28</sup>

Our result will enable effective genetic counselling and heterozygote detection in the family. Further analysis with other probes located in the region of interest and finally mutation analysis of the as yet unidentified gene itself will prove the hypothesis that in this family with Episkopi blindness we are dealing with a mutation within the Norrie disease gene.

We thank Professor Schumacher from the Radiologische Universitätsklinik Freiburg, Sektion Neuroradiologie, for the interpretation of the CT scans, and Mrs Wurich for excellent secretarial assistance.

- Warburg M. Norrie's disease: a new hereditary bilateral pseudotumor of the retina. *Acta Ophthalmol (Copenh)* 1961;39:757-72.
- Warburg M. Norrie's disease, a congenital progressive oculo-acustico-cerebral degeneration. *Acta Ophthalmol (Copenh)* 1966;89(suppl):1-147.
- Parving A, Warburg M. Audiological findings in Norrie's disease. *Audiology* 1977;16:124-31.
- Johnston SS, Hanna JE, Nevin NC, Bryars JH. Norrie's disease. *Birth Defects* 1982;18(6):729-38.
- Gal A, Stolzenberger C, Wienker T, et al. Norrie's disease: close linkage with genetic markers from the proximal short arm of the X chromosome. *Clin Genet* 1985;27:282-3.
- Bleeker-Wagemakers LM, Friedrich U, Gal A, Wienker TF, Warburg M, Ropers HH. Close linkage between Norrie disease, a cloned DNA sequence from the proximal short arm, and the centromere of the X chromosome. *Hum Genet* 1985;71:211-4.
- Kivlin JD, Sanborn GE, Wright E, Cannon L, Carey J. Further linkage data on Norrie disease. *Am J Med Genet* 1987;26:733-6.
- Gal A, Uhlhaas S, Glaser D, Grimm T. Prenatal exclusion of Norrie disease with flanking DNA markers. *Am J Med Genet* 1988;31:449-53.
- Ngo J, Spence MA, Cortessis V, Bateman JB, Sparkes RS. Duplicate report crossing over in Norrie disease family. *Am J Med Genet* 1989;33:286.
- Ngo JT, Spence MA, Cortessis V, Sparkes RS, Bateman JB. Recombinational event between Norrie disease and *DXS7* loci. *Clin Genet* 1988;34:43-7.
- de la Chapelle A, Sankila EM, Lindlof M, Aula P, Norio R. Norrie disease caused by a gene deletion allowing carrier detection and prenatal diagnosis. *Clin Genet* 1985;28:317-20.
- Gal A, Wieringa B, Smeets DFCM, Bleeker-Wagemakers L, Ropers HH. Submicroscopic interstitial deletion of the X chromosome explains a complex genetic syndrome dominated by Norrie disease. *Cytogenet Cell Genet* 1986;42:219-24.
- Donnai D, Mountford RC, Read AP. Norrie disease resulting from a gene deletion: clinical features and DNA studies. *J Med Genet* 1985;25:73-8.
- Zhu D, Antonarakis SE, Schmeckpeper BJ, Diergaard PJ, Greb AE, Maumenee IH. Microdeletion in the X-chromosome and prenatal diagnosis in a family with Norrie disease. *Am J Med Genet* 1989;33:485-8.
- Sims KB, de la Chapelle A, Norio R, et al. Monoamine oxidase deficiency in males with an X chromosome deletion. *Neuron* 1989;2:1069-76.
- Lan NC, Heinzmann C, Gal A, et al. Human monoamine oxidase A and B genes map to Xp 11.23 and are deleted in a patient with Norrie disease. *Genomics* 1989;4:552-9.
- Sims K, Benson G, Hotannislilig G, et al. Further genetic and physical mapping of the Norrie disease locus on Xp11.3. *Am J Hum Genet* 1991;49(suppl):389.
- Taylor PJ, Coates T, Newhouse ML. Episkopi blindness: hereditary blindness in a Greek Cypriot family. *Br J Ophthalmol* 1959;43:340-4.
- Merin S, Lapithin AG, Horowitz D, Michaelson IC. Childhood blindness in Cyprus. *Am J Ophthalmol* 1972;74:538-42.
- Wieacker P, Davies KE, Cooke HJ, et al. Towards a complete linkage map of the human X chromosome; regional assignment of 16 cloned single-copy DNA sequences employing a panel of somatic cell hybrids. *Am J Hum Genet* 1984;36:265-76.
- Willard HE, Schmeckpeper BJ, Smith KD, Goss SJ. High resolution regional mapping of human X-chromosome by radiation induced segregation analysis of X linked DNA probes. *Cytogenet Cell Genet* 1983;37:609-10.
- Fraser NJ, Boyd Y, Brownlee GG, Craig IW. Multi-allelic RFLP for M27 $\beta$ , an anonymous single copy genomic clone at Xp11.3-Xcen [HGM9 provisional no. DXS255]. *Nucleic Acids Res* 1987;15:9616.
- Hsu YPP, Weyler W, Chen S, et al. Structural features of human monoamine oxidase A elucidated from cDNA and peptide features. *J Neurochem* 1988;51:1321-4.
- Feinberg AP, Vogelstein B. A technique for radiolabeling DNA restriction endonuclease fragments to high specific activity. *Anal Biochem* 1984;132:6-13.
- Ott J. A computer program for linkage analysis of general human pedigrees. *Am J Hum Genet* 1976;28:528-9.
- Lathrop GM, Lalouel JM, Julier C, Ott J. Multilocus linkage analysis in humans: detection of linkage and estimation of recombination. *Am J Hum Genet* 1985;37:482-98.
- Mahtani MM, Lafrenière RG, Kruse TA, Willard HF. An 18-locus linkage map of the pericentric region of the human X chromosome: genetic framework for mapping X-linked disorders. *Genomics* 1991;10:849-57.
- Collins FA, Murphy DL, Reiss AL, et al. Clinical, biochemical, and neuropsychiatric evaluation of a patient with a contiguous gene syndrome due to a microdeletion Xp11.3 including the Norrie disease locus and monoamine oxidase (*MAOA* and *MAOB*) genes. *Am J Med Genet* 1992;42:127-34.