

Incidence of manifest glaucoma

BO BENGTTSSON

From the Departments of Research in Primary Health Care and Experimental Ophthalmology, University of Lund, Sweden

SUMMARY The incidence of manifest glaucoma was determined by means of repeated automatic perimetry in a defined general population. It was estimated at 0.24% per year. It was largely independent of age but higher in women than in men and higher in the countryside than in the villages. In fact the incidence of manifest glaucoma was five times higher among women in the countryside than among men in the villages.

In a population the occurrence of a disease is described by prevalence and incidence. The proportion being diseased at a certain point of time is called prevalence. The proportion becoming diseased during a certain period is called incidence. In other words: prevalence measures the probability of having a disease; incidence the risk of getting it. Prevalence is the product of the incidence and the duration of a disease. Incidence is, accordingly, the more fundamental of the two concepts.

A single survey of the population suffices to determine the prevalence of a disease. Repeated surveys are needed for a direct measurement of the incidence of asymptomatic cases. Not surprisingly 'the incidence of glaucoma in a defined general population has not been adequately measured'.¹ Existing indirect estimates are far from unanimous.²⁻⁵

We have performed repeated visual field screening^{6,7} during a longitudinal study of the natural history of glaucoma. Very few participants were treated for ocular hypertension. The present material, therefore, provided us with an opportunity to measure the incidence of manifest glaucoma in a defined general population.

Material and methods

Letters within brackets refer to Fig. 1.

All Dalby residents born 1907-21 were listed in December 1976. The list was kept up to date by means of reports on removals and deaths. Of the listed persons 14 were treated for ocular hypertension before the first survey; 1938 were invited and 1511 examined. Manifest glaucoma was diagnosed in 15 persons (V) at the first survey and treatment for

ocular hypertension was started in six others.

During the interval between the first and the second examination 10 subjects left the county and 53 died (B).

Of the 1427 remaining persons 1295 took part in the second survey. Manifest glaucoma was diagnosed in five persons (X). Those not attending were retained in the study (L).

During the interval between the second and the third examination 13 subjects left the county and 160 died (C, CL). Manifest glaucoma was diagnosed in six cases (Y).

Of the 1243 remaining persons 1039 took part in the third survey. All but 32 of them had taken part in the second survey too (PL, ZL).

Age and sex distributions are given in Table 1.

The surveys. Automatic screening perimetry, fundus photography, ophthalmoscopy, slit-lamp examination, and Goldmann tonometry were all attempted in the same way and by the same staff each time on every person who took part in the study. Detailed descriptions of automatic perimetry and optic disc photography, for the present purpose, have been given elsewhere.^{7,8}

Patients followed up for shorter intervals. Patients treated for ocular hypertension were followed up by the author or at the regional hospital. According to the records all had been subjected to automatic perimetry at least once every year. The author used the same methods as in the survey. Patients followed up at the regional hospital were usually subjected to threshold perimetry rather than to screening perimetry.

Definition of manifest glaucoma. A person was considered to suffer from manifest glaucoma when a repeatable visual field defect, consistent with glaucoma and not explicable on other grounds,

Correspondence to Dr B Bengtsson, Vårdcentralen, S-240 10 Dalby, Sweden.

Table 1 Age and sex distribution of the material

| Birth year | Removed, died | | | Did not attend | | | | Acquitted* | | With manifest glaucoma | | | | | | | |
|--------------|---------------|----|----|----------------|----|----|----|------------|----|------------------------|---|---|---|---|---|---|----|
| | B | C | CL | K | L | M | ML | P | PL | T | U | V | W | X | Y | Z | ZL |
| <i>Men</i> | | | | | | | | | | | | | | | | | |
| 07-11 | 14 | 42 | 2 | 80 | 17 | 21 | 12 | 134 | 3 | 0 | 1 | 2 | 0 | 2 | 0 | 1 | 0 |
| 12-16 | 13 | 33 | 5 | 60 | 25 | 17 | 16 | 189 | 4 | 1 | 1 | 0 | 1 | 1 | 1 | 0 | 0 |
| 17-21 | 15 | 26 | 3 | 82 | 23 | 22 | 12 | 160 | 8 | 0 | 0 | 0 | 0 | 0 | 1 | 1 | 0 |
| <i>Women</i> | | | | | | | | | | | | | | | | | |
| 07-11 | 11 | 24 | 5 | 90 | 25 | 26 | 15 | 149 | 5 | 2 | 0 | 6 | 1 | 1 | 2 | 0 | 0 |
| 12-16 | 7 | 18 | 2 | 52 | 19 | 21 | 11 | 166 | 6 | 0 | 1 | 4 | 0 | 0 | 1 | 2 | 0 |
| 17-21 | 3 | 11 | 2 | 63 | 23 | 16 | 15 | 204 | 5 | 0 | 2 | 3 | 2 | 1 | 1 | 1 | 1 |

B = Removed or died between the first two surveys.

C, CL = Removed or died between the latest two surveys.

K = Did not attend the first survey.

L, CL, ML, PL, ZL = Did not attend the second survey.

M, ML = Did not attend the third survey.

P, PL = Acquitted at the third survey.

T = Detected among persons not attending the first survey.

U = Detected among persons treated for OH before the first survey.

V = Detected among persons examined at the first survey.

W = Detected among persons treated for OH after the first survey.

X = Detected among persons examined at the second survey.

Y = Detected among persons followed after the second survey.

Z, ZL = Detected among persons examined at the third survey.

*Found not to have manifest.

coexisted with a corresponding loss of neural tissue in the optic nerve head of the same eye. Only cases confirmed at a subsequent visit have been included in the present study.

Calculation of incidence. The incidence (I) was calculated as $m/(nF-0.5 mF)$, where m is the number of cases detected among n persons examined and F the mean interval (in years) between two surveys.

In the calculation of the incidence cases of manifest glaucoma detected before a survey were considered to have been examined and detected at the survey. They were counted only if they still remained in the county at the time of the survey, and their number was reduced through multiplication by the attendance at the survey (attendance=number of persons examined/number invited).

Results

Letters within brackets refer to Fig. 1.

Of the six patients treated for ocular hypertension after the first survey four developed manifest glaucoma before the second survey (W). One patient developed a visual field defect, probably as a result of macular degeneration. The sixth was treated at his own request.

At the second survey we detected five cases of manifest glaucoma (X).

Between the second and the third survey glaucomatous visual field defects were detected in six glaucoma suspects (Y).

At the third survey we detected six cases of manifest glaucoma (Z, ZL).

The mean interval was 2.75 years between the first two surveys and 5.65 years between the two latest ones.

Of 14 patients treated for ocular hypertension from before the start of the first survey two died and five developed manifest glaucoma before the end of the third survey (U). Treatment was discontinued in two of the remaining patients and reduced to a single drop each day in another one.

Among persons not attending the first survey a few were later examined by the author. In this way manifest glaucoma was detected in three additional cases (T). As in the 15 cases detected at the first survey (V) the duration of the visual field defects was of course unknown. It could, however, be roughly estimated from the size of the defects. By this method seven defects were found to be fresh and 11 to be of some duration.

Among surveyed persons the incidence of manifest glaucoma was 0.0024/year between the two first surveys and 0.0019/year between the two latest surveys.

The overall incidence, including that in all persons treated for ocular hypertension was 0.0024/year (SE 0.0005).

This estimate was based on 26 incident cases—that is, all cases of manifest glaucoma known to have appeared after the first survey. The following statements are based on 44 cases—that is, all cases of

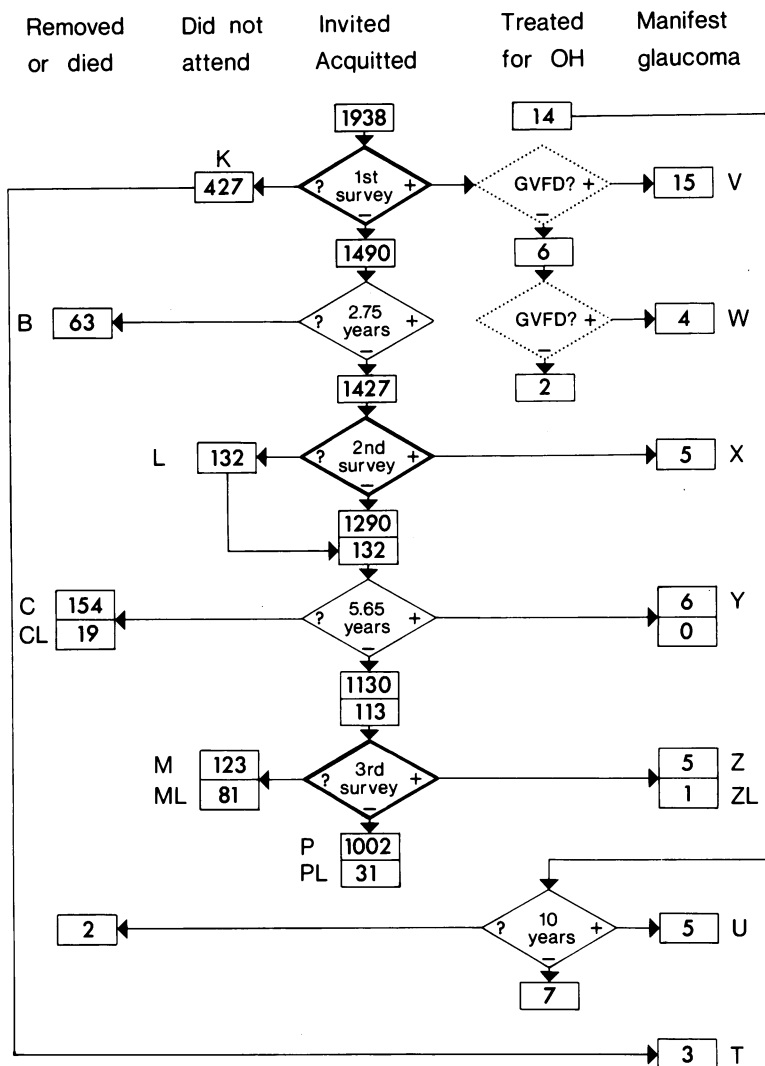

Fig. 1 Flow diagram showing number of persons examined, lost, treated, etc. 'Acquitted' means found not to have manifest glaucoma and not to need treatment for ocular hypertension.

manifest glaucoma detected in 1977-87 in persons born in 1907-21 and living in the Dalby district when listed in December 1976.

Manifest glaucoma was rare in men aged less than 65 years (Fig. 2). With this exception the incidence of glaucoma was largely independent of age (Fig. 2).

Men were as frequent as women in the population, but we found 31 women and only 13 men with manifest glaucoma ($p < 0.01$).

The number of persons living in the countryside when listed before the first survey was only half the number of persons living in the small villages. Nevertheless we found manifest glaucoma in 23 countrymen and 21 villagers ($p < 0.05$).

The age and sex distribution was very nearly the same in the countryside as in the villages, and the

incidence of manifest glaucoma was five times higher among women in the countryside than among men in the villages.

Discussion

The present estimate of the incidence of manifest glaucoma in persons born in 1907-21 (0.24% per year) is similar to that in Dalby residents born before 1907 (0.22% per year),³ but in the case of persons in their 50s and 60s much higher than those obtained elsewhere.^{4,5} It is therefore not surprising that our observation that manifest glaucoma is commoner in women than in men aged under 65^{2,9} has not been confirmed by others.

As so often before,¹⁰ treatment of ocular hyperten-

LEXIS diagram

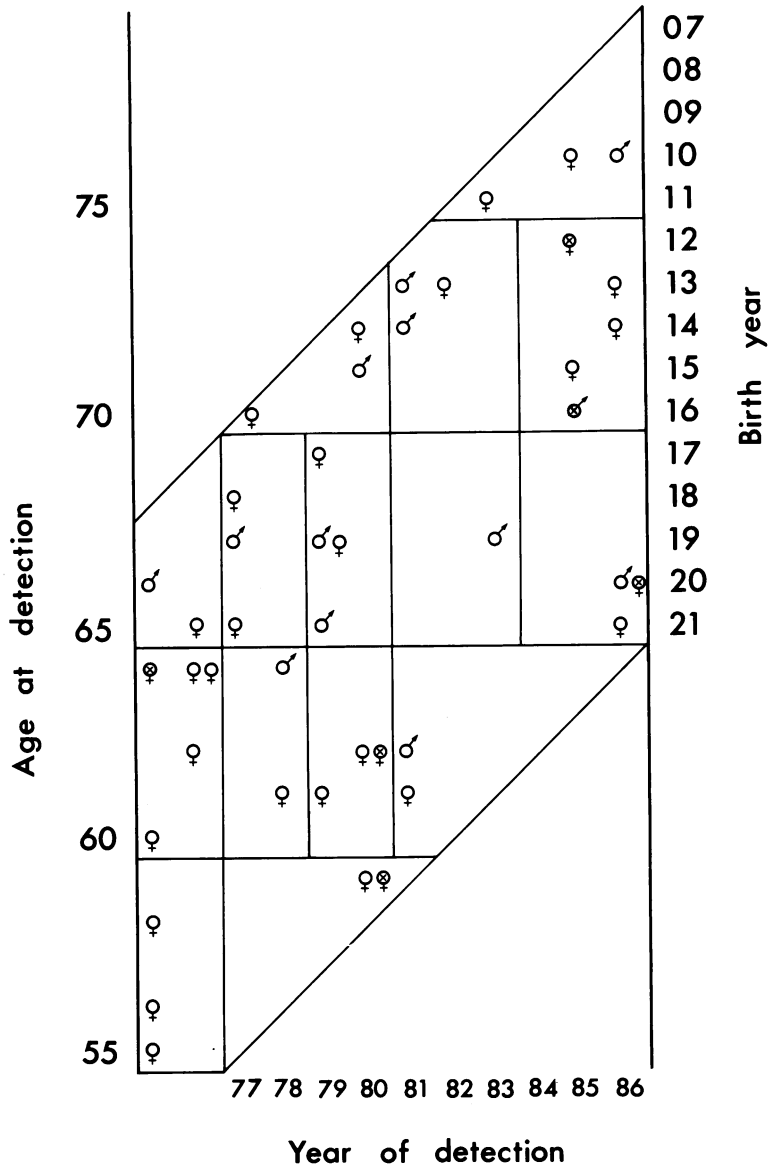

Fig. 2 A Lexis diagram. It describes the incidence of manifest glaucoma in the whole study on the assumption that 11 large defects could have been found at least two years before their actual detection. The total area was divided into 15 compartments, each representing about 1250 person-years. Symbols with X in them represent patients with capsular glaucoma.

sion was found not to prevent the development of glaucomatous visual field defects. To the extent that secondary prevention—that is, early diagnosis and treatment—of glaucoma loses prestige with the profession, primary prevention seems more urgent. The dependence suggested here of the occurrence of manifest glaucoma on residential factors calls for further studies of external causes of glaucoma.

This work was supported by the Swedish Medical Research Council (B89-27X-07527-04C) and Kung Gustaf V:s och Drottning Victorias Stiftelse.

References

- 1 Leske MC. The epidemiology of open-angle glaucoma: a review. *Am J Epidemiol* 1983; **118**: 166-91.
- 2 Bengtsson B. The prevalence of glaucoma. *Br J Ophthalmol* 1981; **65**: 46-9.

- 3 Bengtsson B. Manifest glaucoma in the aged I: Occurrence nine years after a population survey. *Acta Ophthalmol (Kbh)* 1981; **59**: 321–31.
- 4 Podgor MJ, Leske MC, Ederer F. Incidence estimates for lens changes, macular changes, open-angle glaucoma and diabetic retinopathy. *Am J Epidemiol* 1983; **118**: 206–12.
- 5 Lindblom B, Thorburn W. Observed incidence of glaucoma in Hälsingland, Sweden. *Acta Ophthalmol (Kbh)* 1984; **62**: 217–22.
- 6 Bengtsson B. Repeated automatic visual field screening in a cohort study. *Acta Ophthalmol (Kbh)* 1985; **63**: 242–4.
- 7 Bengtsson B, Krakau CET. Automatic perimetry in a population survey. *Acta Ophthalmol (Kbh)* 1979; **57**: 929–37.
- 8 Bengtsson B, Krakau CET. A simple routine for optic disc photography through a natural pupil. *Acta Ophthalmol (Kbh)* 1979; **57**: 151–4.
- 9 Bengtsson B, Holmin C, Krakau CET. Disc haemorrhage and glaucoma. *Acta Ophthalmol (Kbh)* 1981; **59**: 1–14.
- 10 Pohjanpelto P. Influence of exfoliation syndrome on prognosis in ocular hypertension. *Acta Ophthalmol (Kbh)* 1986; **64**: 39–44.

Accepted for publication 3 November 1988.