

## Short reports

# X chromosome inactivation pattern in female carriers of X linked hypophosphataemic rickets

Karen Helene Ørstavik, Ragnhild Elise Ørstavik, Johan Halse, Jørgen Knudtson

### Abstract

**X linked hypophosphataemia (XLH) results from an abnormality of renal tubular phosphate reabsorption. The disorder is inherited as an X linked dominant trait and the gene has been mapped to Xp22.1-p22.2. A candidate gene (PEX) has recently been isolated. The most striking clinical features are growth retardation and skeletal abnormalities. As expected for X linked dominant disorders, females are less affected. However, such a gene dosage effect does not exist for renal phosphate reabsorption. Preferential X chromosome inactivation has been proposed as a possible explanation for this lack of gene dosage. We have examined the X inactivation pattern in peripheral blood cells from 12 females belonging to seven families with XLH using PCR analysis at the androgen receptor locus. The X inactivation pattern in these patients did not differ significantly from the pattern in 30 healthy females. The X inactivation pattern in peripheral blood cells does not necessarily reflect the X inactivation pattern in renal cells. However, the finding of a normal distribution of X inactivation in peripheral blood cells indicates that the similarity in the renal handling of phosphate in male and female patients is not related to a ubiquitous preferential X inactivation.**

(*J Med Genet* 1996;33:700-703)

Key words: hypophosphataemic rickets; X inactivation; gene dosage.

Familial vitamin D resistant rickets or X linked hypophosphataemia (XLH) is an X linked, dominantly inherited abnormality of renal tubular phosphate transport. The gene has been mapped to Xp22.1-p22.2.<sup>1</sup> A candidate gene (PEX) with homologies to endopeptidases has recently been isolated.<sup>2</sup> The most common manifestations in children are short stature and bowing of the lower extremities, whereas adults primarily develop dental disease and osteoarthritis.

In an X linked dominant disorder a gene dosage effect is expected, causing a milder dis-

ease in females than in males. In a recent review, Scriver and Tenenhouse<sup>3</sup> reported the unusual organ specific gene dosage which is found in XLH. Gene dosage effects have been found in mineralised tissue, both in bone<sup>4,5</sup> and teeth.<sup>6</sup> However, no difference between males and females has been found in the renal handling of phosphate. Quantitative measures of renal phosphate reabsorption are not significantly different in male and female patients.<sup>4,7</sup> The renal phenotype therefore seems to be fully dominant without a gene dosage effect.

In female mammalian cells one of the two X chromosomes is inactivated.<sup>8</sup> This inactivation is thought to be random, affecting either the paternal or the maternal X chromosome. By chance, X chromosome inactivation will lead to a skewed pattern in some females, with the paternal or maternal X as the active X in most cells. Female carriers of X linked recessive disorders may therefore on rare occasions be affected. In female carriers of X linked dominant disorders a greater variation in manifestation of the disorder is expected, depending on the pattern of X inactivation. Indeed, females who are obligate carriers of XLH have been described without any evidence of bone disease.<sup>5</sup>

A skewed X inactivation in carriers of X linked disorders may be the result of a post-transcriptional selection against the X chromosome carrying the mutant or the wild type allele. One suggested explanation for the dominant renal phenotype is the preferential inactivation of the X chromosome carrying the wild type allele.<sup>3</sup>

We therefore determined the X inactivation pattern in 13 females with XLH and compared it with the X inactivation pattern in 30 control females.

### Materials and methods

#### SUBJECTS

Thirteen female patients with XLH were examined (table 1). Ten of the females belonged to four families with more than one affected patient, whereas the remaining three patients had no family history of XLH (fig 1). All patients except the obligate carrier of family B (IV.1) were examined by one of us, and the diagnosis was based on typical clinical, radiological, and biochemical parameters.

Department of  
Medical Genetics,  
Ullevål University  
Hospital, Box 1036  
Blindern, 0315 Oslo,  
Norway  
K H Ørstavik  
R E Ørstavik

Department of  
Internal Medicine,  
National Hospital,  
Oslo, Norway  
J Halse

Department of  
Endocrinology,  
National Hospital,  
Oslo, Norway  
J Knudtson

Correspondence to:  
Dr Ørstavik.

Received 28 September 1995  
Revised version accepted for  
publication 12 March 1996

Table 1 X inactivation pattern in female carriers of XLH

Family	Patient	Age (y)	Age at diagnosis (y)	Serum phosphate (mmol/l)*	X inactivation pattern
A	II.1	70	70	0.9	Moderately skewed
	III.1	53	Childhood	0.7	Not informative
	III.2	46	Childhood	0.7	Skewed
	IV.1	25	1	1.0	Moderately skewed
B	II.1	54	2	0.6	Moderately skewed
	III.1	28	2	0.8	Random
	IV.1	0	0†		Moderately skewed
C	II.1	41	3	0.4	Random
	II.2	40	1 1/2	0.5	Moderately skewed
D	II.1	47	2	0.7	Random
E	II.1	21	1 1/2	0.9	Moderately skewed
F	II.1	65	Childhood	0.5	Moderately skewed
G	II.1	60	Childhood	0.9	Random

\*Lower normal range of serum phosphate level (- 2.5 SD) corresponds to approximately 1.3 mmol/l in infancy, decreasing to 1.1 at the age of 5 years, 0.8 in adulthood, and increasing to 0.9 in old age.<sup>9</sup>

†Obligate carrier.

X inactivation: random 50:50-65:35, moderately skewed >65:35-80:20, skewed >80:20-95:5.

All patients were diagnosed in early childhood except patient II.1 in family A. This patient was examined at the age of 70 years when her daughter was referred for genetic counselling. She had very carious teeth in childhood and adolescence but considered herself healthy and had not previously been diagnosed as having XLH. She had short legs, left sided genu valgum, and radiological findings in agreement with rickets. She had a serum phosphate concentration of 0.9 mmol/l, which is in the lower normal range for a female of 70 years (table 1). Two of her four daughters (III.1 and III.2) were diagnosed in childhood and had been operated on several times for genua vara. Otherwise they had not received any treatment. Patient II.1 of family B had also

not received any medical treatment. The remaining patients were treated with vitamin D.

The two sisters of family C had classical XLH. A younger brother (II.3) died in infancy, but a diagnosis could not be provided. Their father is dead and was rather short (170 cm). Their mother had lost her teeth at an early age, but was not available for further examination. It is therefore not possible to determine the origin of the mutant allele in this family.

Blood samples were obtained from the patients with informed consent and DNA was isolated by standard procedures. DNA from apparently healthy medical students was used as controls.

MOLECULAR GENETIC ANALYSIS OF X INACTIVATION

The X inactivation pattern was determined using PCR analysis of the first exon of the androgen receptor locus which contains a highly polymorphic trinucleotide repeat.<sup>10</sup> Methylation of *HpaII* sites close to this short tandem repeat has been found to correlate with X chromosome inactivation. The *HpaII* site on the inactive X chromosome is methylated and resists cleavage by the enzyme. PCR products were obtained from the inactive X chromosome only, and were separated on a polyacrylamide gel and exposed to x ray films (fig 2). The density of the bands representing the maternal and paternal allele were determined using a Shimadzu Scanner (CS 9000). The details of the PCR analysis have been described previously.<sup>11</sup>

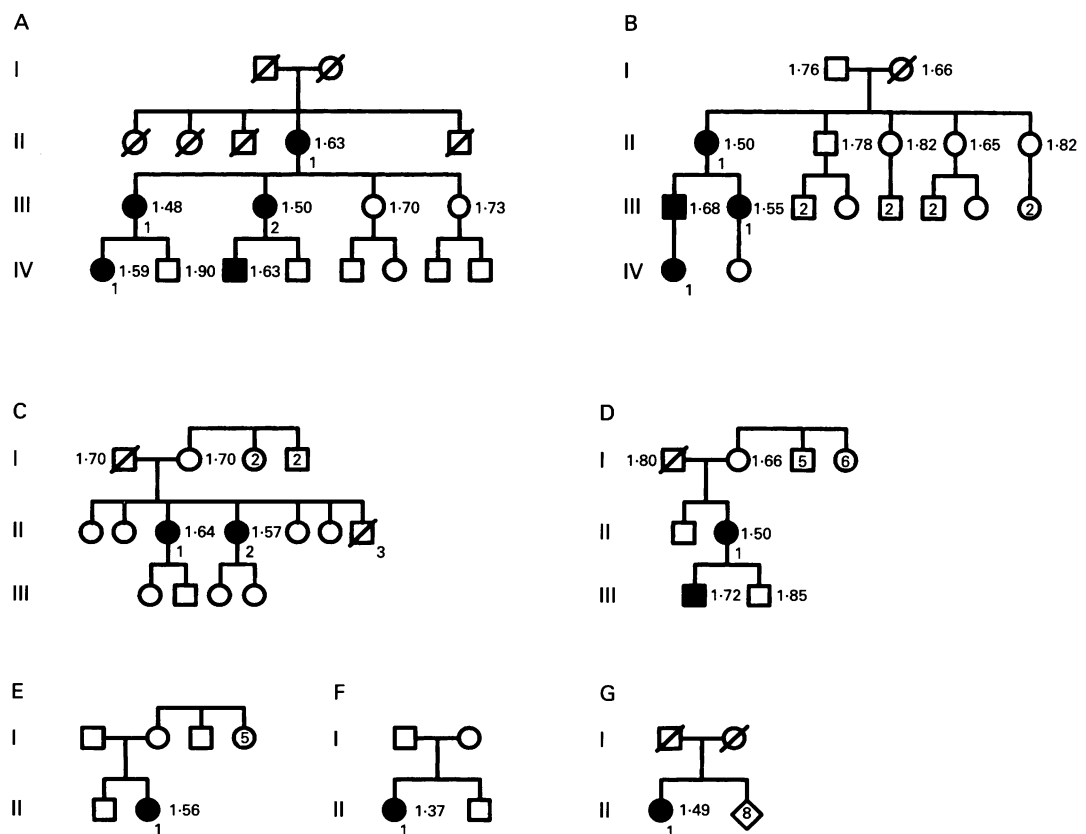

Figure 1 Pedigrees of families with adult height.

Table 2 Distribution of X inactivation pattern in XLH and control females

	XLH females	Control females*
	No (%)	No (%)
Random (50:50-65:35)	4 (33.3)	19 (63.3)
Moderately skewed (>65:35-80:20)	7 (58.3)	7 (23.3)
Skewed (>80:20-95:5)	1 (8.3)	4 (13.3)
Total	12 (100)	30 (100)

p = 0.09 (Mann-Whitney test corrected for ties).

\*Values from Ørstavik *et al.*<sup>11</sup>

X inactivation patterns were classified as random (ratios 50:50-65:35), moderately skewed (ratios >65:35-80:20), skewed (ratios >80:20-95:5), and extremely skewed (ratio >95:5). The distribution of the X inactivation patterns of the patients and the controls were compared using the Mann-Whitney test with correction for tied observations.

### Results

Twelve of 13 patients were heterozygous for the trinucleotide repeat and therefore informative. The results of X inactivation analysis in the patients are shown in fig 2 and table 1. There was a smaller number of patients with a random X inactivation pattern and a larger number with a moderately skewed pattern compared to the controls, but this difference was not significant (p=0.09, Mann-Whitney test) (table 2). None of the patients or controls had an extremely skewed pattern.

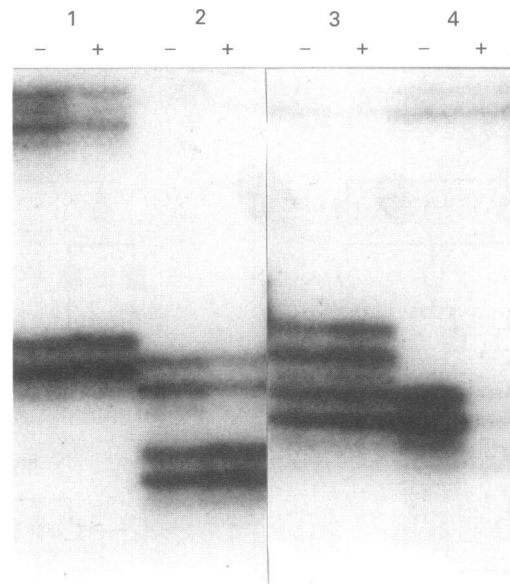

Figure 2 X chromosome inactivation analysis at the androgen receptor locus. Lane 1: patient II.2, family C. Lane 2: patient II.1, family E. Lane 3: patient II.1, family D. Lane 4: patient III.1, family D (male). -: undigested DNA, +: HpaII digested DNA. Each allele in the AR locus is represented by two stronger and one weaker band (shadow band), owing to the two complementary DNA strands migrating slightly differently during electrophoresis. For patients II.2, family C (lane 1 +) and II.1, family E (lane 2 +) the upper band is fainter than the lower band, corresponding to a moderately skewed X inactivation. For patient II.1, family D, the upper and lower bands show equal intensity after HpaII digestion, corresponding to random X inactivation (lane 3 +). A PCR product is seen from the inactive allele only; therefore there is no PCR product after HpaII digestion in a male (lane 4 +).

### Discussion

Selection against cells containing the mutant allele on the active X chromosome has been reported in several X linked disorders, such as, for instance, incontinentia pigmenti<sup>12</sup> and Wiskott-Aldrich syndrome.<sup>13</sup> This has been advantageous and led to a normal phenotype in carriers. However, selection against cells containing the wild type allele on the active X chromosome has also been reported, such as in cultured fibroblasts from females heterozygous for X linked adrenoleucodystrophy.<sup>14</sup> Since blood cells have a very great number of cell divisions, even a slight selection against the normal allele in blood cells would eventually lead to a non-random X inactivation pattern in these cells.

Females with XLH have a milder bone disease than males, as expected for an X linked dominant disorder.<sup>3 6 7</sup> However, there does not seem to be such a gene dosage effect for the renal phenotype. Preferential inactivation of the X chromosome carrying the normal allele in renal tubule cells could be one explanation for this phenomenon.

The X inactivation pattern in peripheral blood cells in the 12 patients did not differ significantly from the pattern found in 30 control females. It is therefore not likely that a ubiquitous preferential inactivation of the X chromosome carrying the wild type allele is the explanation for lack of dosage effect on the renal defect in XLH. Random X inactivation in peripheral blood cells, however, does not exclude the possibility of non-random X inactivation in renal tubule cells. This could arise by selection against cells with the wild type allele on the active X chromosome in certain tissues only. Furthermore, the number of patients in our study was small, and we do not know if the skewing in the eight patients with non-random X inactivation was directed towards the mutant or wild type allele. A larger series of patients with a known direction of the skewing may decide if there is a significant excess of skewing in peripheral blood cells in patients compared to normal females.

X inactivation may contribute to a more variable phenotype in females than in males with X linked dominant disorders. It would therefore be of interest to correlate X inactivation pattern with severity of bone disease. The severity of XLH is difficult to assess precisely and clinical manifestations may be modified by treatment. However, in severely affected patients in this material, both a skewed pattern (patient III.2, family A) and a random pattern (patients III.1, family B, II.1, family C, II.1, family D, and II.1, family G) was found (table 1). It therefore does not seem likely that the phenotype of bone disease is correlated to X inactivation pattern in peripheral blood cells.

The study of X inactivation in renal tubule cells and bone will be necessary to elucidate the role of X chromosome inactivation in the phenotypic expression of XLH in females.

This work was supported by Anders Jahres Foundation for Promotion of Science, The Fridtjof Nansen Foundation, The Research Council of Norway, and Ullevål University Hospital Research Forum.

- 1 Rowe PSN, Goulding J, Read A, *et al.* Refining the genetic map for the region flanking the X-linked hypophosphataemic rickets locus (Xp22.1-22.2). *Hum Genet* 1994; 93:291-4.
- 2 The HYP Consortium. A gene (PEX) with homologies to endopeptidases is mutated in patients with X-linked hypophosphataemic rickets. *Nature Genet* 1995;11:130-47.
- 3 Scriver CR, Tenenhouse HS. X-linked hypophosphatemia: A homologous phenotype in humans and mice with unusual organ-specific gene dosage. *J Inherited Metab Dis* 1992;15:610-24.
- 4 Winters RW, Graham JB, Williams TF, McFalls VW, Burnett CH. A genetic study of familial hypophosphatemia and vitamin D resistant rickets with a review of the literature. *Medicine* 1958;37:97-142.
- 5 Burnett CH, Dent CE, Harper C, Warland BJ. Vitamin D-resistant rickets: analysis of twenty-four pedigrees with hereditary and sporadic cases. *Am J Med* 1964;36:222-32.
- 6 Shields ED, Scriver CR, Reade T, *et al.* X-linked hypophosphatemia: the mutant gene is expressed in teeth as well as in kidney. *Am J Hum Genet* 1990;46:434-43.
- 7 Reid IR, Hardy DC, Murphy WA, *et al.* X-linked hypophosphatemia: clinical, biochemical and histopathologic assessment of morbidity in adults. *Medicine* 1989;68:336-52.
- 8 Lyon M. Gene action in the X-chromosome of the mouse (*mus musculus* L.). *Nature* 1961;190:372-4.
- 9 Greenberg BG, Winters RW, Graham JB. The normal range of serum inorganic phosphorus and its utility as a discriminant in the diagnosis of congenital hypophosphatemia. *J Clin Endocrinol Metab* 1960;20:364-79.
- 10 Allen RC, Zoghbi HY, Moseley AB, Rosenblatt HM, Belmont JW. Methylation of HpaII and HhaI sites near the polymorphic CAG repeat in the human androgen-receptor gene correlates with X chromosome inactivation. *Am J Hum Genet* 1992;51:1229-39.
- 11 Ørstavik RE, Tommerup N, Eiklid K, Ørstavik KH. Non-random X chromosome inactivation in affected twin in a monozygotic twin pair discordant for Wiedemann-Beckwith syndrome. *Am J Med Genet* 1995;56:210-14.
- 12 Migeon BR, Axelman J, Jan de Beru S, Valle D, Mitchell GA, Rosenbaum KN. Selection against lethal alleles in females heterozygous for incontinentia pigmenti. *Am J Hum Genet* 1989;44:100-6.
- 13 Fearon E, Kohn DB, Winkelstein JA, Vogelstein B, Blaeser RM. Carrier detection in the Wiskott-Aldrich syndrome. *Blood* 1988;72:1735-9.
- 14 Migeon BR, Moser HW, Moser AB, Axelman J, Sillence D, Norum RA. Adrenoleukodystrophy: evidence for X-linkage, inactivation, and selection favoring the mutant allele in heterozygous cells. *Proc Natl Acad Sci USA* 1981; 78:5066-70.