

# Localisation of X linked recessive idiopathic hypoparathyroidism to a 1.5 Mb region on Xq26-q27

D Trump, P H Dixon, S Mumm, C Wooding, K E Davies, D Schlessinger, M P Whyte, R V Thakker

## Abstract

**X linked recessive idiopathic hypoparathyroidism (HPT) has been observed in two kindreds from Missouri, USA. Affected subjects, who are males, suffer from infantile onset of epilepsy and hypocalcaemia, which appears to be the result of an isolated congenital defect of parathyroid gland development; females are not affected and are normocalcaemic. The gene causing HPT has been previously mapped to a 7 cM interval, flanked centromerically by F9 and telomerically by DXS98, in Xq26-q27, and an analysis of mitochondrial DNA has established a common ancestry for these two kindreds. In order to define further the map location of HPT and thereby facilitate its isolation, we have undertaken linkage studies using polymorphic loci whose order has been established as Xcen - DXS1001 - DXS294 - DXS102 - F9 - DXS1232 - DXS984 - CDR1 - DXS105 - DXS1205 - DXS1227 - DXS98 - DXS52 - Xqter, within this region. Our results established linkage (lod score >3) between HPT and eight of these 12 loci and indicated that the most likely location of HPT was within a 1.5 Mb interval flanked centromerically by F9 and telomerically by DXS984. Thus, the results of this study have helped to refine the map location of HPT, and this will facilitate the identification of this putative developmental gene and its role in the embryological formation of the parathyroids.**

(*J Med Genet* 1998;35:905-909)

Keywords: parathyroid gland development; hypocalcaemia

Hypoparathyroidism is an endocrine disorder in which hypocalcaemia and hyperphosphataemia are the results of a deficiency of parathyroid hormone (PTH) secretion.<sup>1,2</sup> There are a variety of causes of hypoparathyroidism and the disorder may occur after trauma to the parathyroids during neck surgery, or as part of the autoimmune polyendocrinopathy-candidiasis-ectodermal dystrophy (APECED) syndrome, or as a congenital defect as in DiGeorge syndrome. In addition, hypoparathyroidism may develop as a solitary endocrinopathy and this form has been called isolated or idiopathic hypoparathyroidism.<sup>3</sup> Familial occurrences of idiopathic hypoparathyroidism have been re-

ported and autosomal dominant,<sup>4,5</sup> autosomal recessive,<sup>6,7</sup> and X linked recessive inheritances<sup>8-10</sup> have been established.<sup>1</sup> Some of the autosomal forms of hypoparathyroidism have been shown to be the result of either mutations of the PTH gene,<sup>5,7</sup> which is located on chromosome 11p15,<sup>11,12</sup> or of the calcium sensing receptor gene,<sup>13,14</sup> which is located on chromosome 3q13.3-3q21.<sup>15</sup> The gene causing the X linked recessive form, which is likely to involve a putative, developmental gene<sup>16</sup> and has been mapped to Xq26-q27,<sup>10</sup> remains to be isolated.

X linked recessive idiopathic hypoparathyroidism (HPT) has been reported to occur in two multigeneration kindreds, family P/60 and W/81 (fig 1), from Missouri, USA.<sup>8,9</sup> Affected subjects, who are males, suffered from neonatal or infantile onset of hypocalcaemic seizures that were invariably fatal if the hypocalcaemia remained uncorrected. Further investigations of these male patients showed undetectable circulating immunoreactive PTH concentrations and a normal renal response to bovine PTH extract.<sup>9</sup> In addition, necropsy of an affected teenage boy from family P/60 indicated that the deficiency in PTH was the result of parathyroid gland agenesis.<sup>16</sup> Clinical immunodeficiency, a notable feature of DiGeorge syndrome,<sup>1,2</sup> has not been observed in any of the affected males. Unaffected relatives including carrier females, who were the mothers or grandmothers of affected boys, had no history of epilepsy and were normocalcaemic.

The two HPT kindreds, which are both from eastern Missouri, appeared to be unrelated, as a common ancestor was not identified despite extensive genealogy dating back to the mid-1800s. However, an analysis of mitochondrial DNA, which is maternally inherited, identified that the D loop sequences in the affected males from both kindreds were identical, thereby establishing their common ancestry.<sup>17</sup> Linkage studies have mapped the HPT gene to a 7 cM interval flanked centromerically by factor IX (F9) and telomerically by DXS98 in Xq26-Xq27.<sup>10</sup> We have pursued additional linkage studies in these two HPT families using 12 polymorphic markers, with the aim of further defining the chromosomal segment containing HPT, and thereby facilitating its identification by positional cloning.<sup>18</sup>

## Materials and methods

### FAMILIES

Two kindreds from Missouri, in whom idiopathic hypoparathyroidism had been inherited

MRC Molecular Endocrinology Group, MRC Clinical Sciences Centre, Imperial College School of Medicine, Hammersmith Hospital, Du Cane Road, London W12 0NN, UK  
D Trump  
P H Dixon  
C Wooding  
R V Thakker

Department of Molecular Microbiology and Center for Genetics in Medicine, Washington University School of Medicine, St Louis, MO 63110, USA  
S Mumm  
D Schlessinger

Genetics Laboratory, Department of Biochemistry, University of Oxford, South Parks Road, Oxford OX1 3QU, UK  
K E Davies

Metabolic Research Unit, Shriners Hospital for Children, St Louis, MO 63131, USA  
M P Whyte

Division of Bone and Mineral Diseases, Washington University School of Medicine, St Louis, MO 63110, USA  
M P Whyte

Correspondence to: Professor Thakker.

Received 5 January 1998  
Revised version accepted for publication 23 April 1998

**A**  
Family W/81

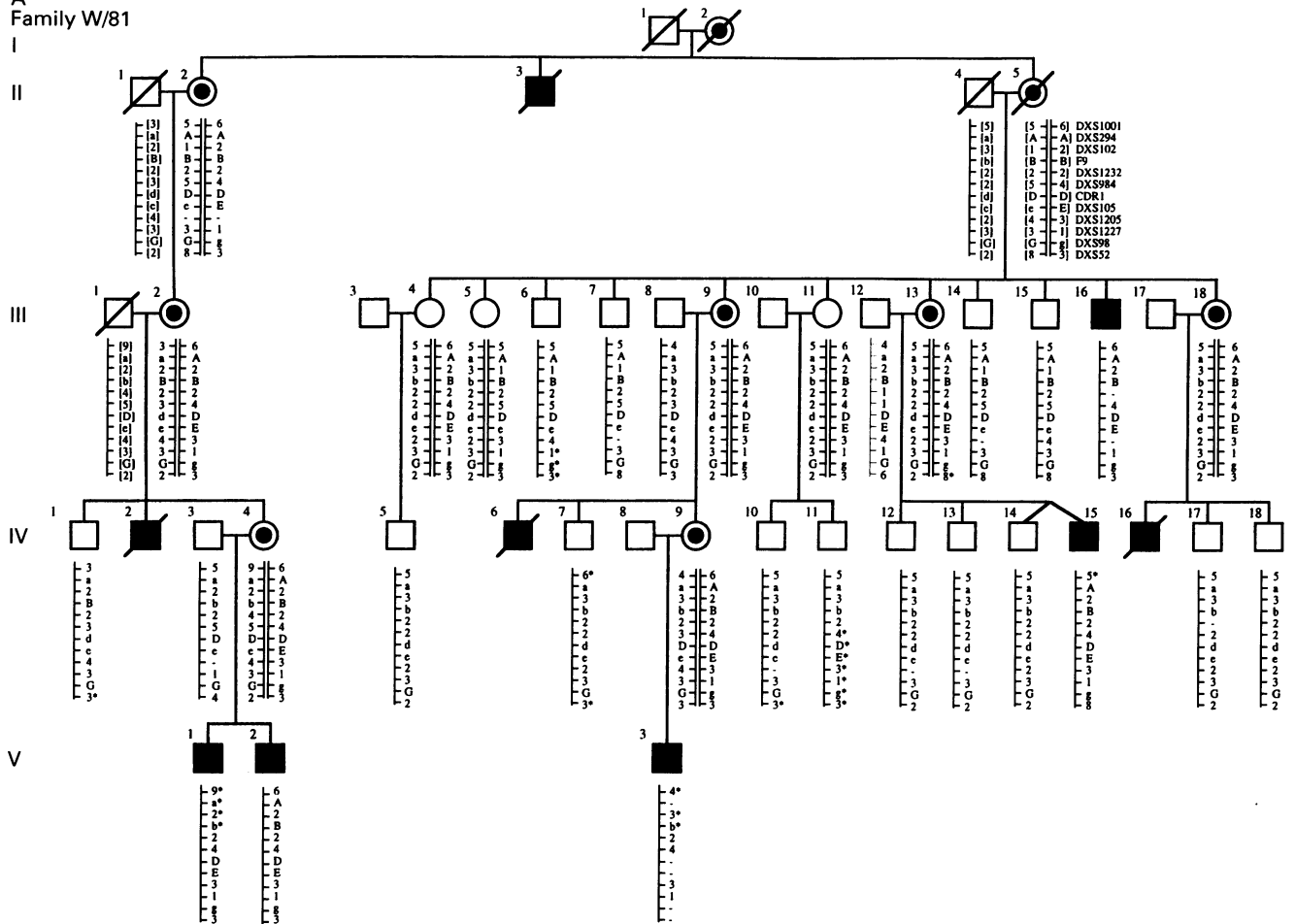

**B**  
Family P/60

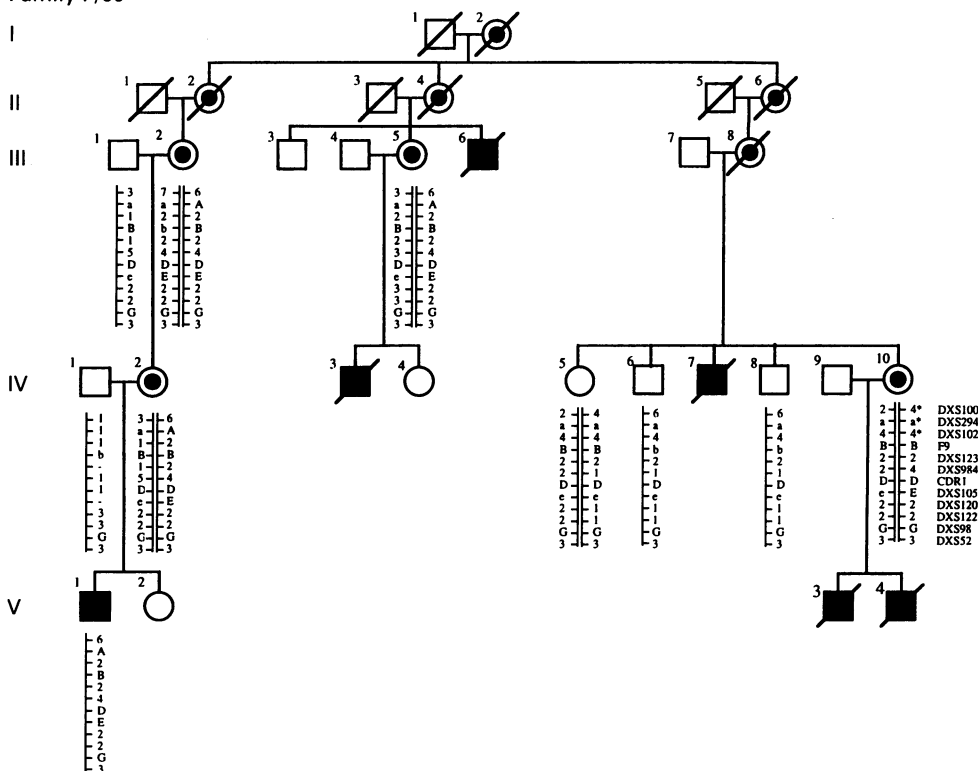

Figure 1 Pedigrees from families W/81 (A) and P/60 (B), segregating for X linked recessive idiopathic hypoparathyroidism and the 12 polymorphic loci (Xcen - DXS1001 - DXS294 - DXS102 - F9 - DXS1232 - DXS984 - CDR1 - DXS105 - DXS1205 - DXS1227 - DXS98 - DX52 - Xqter) from Xq26-Xq27, whose respective alleles are indicated. Filled in symbols are affected subjects, symbols with a dot in the middle are carriers. In some females, the inheritance of paternal and maternal alleles can be ascertained, and in these the paternal X chromosome haplotype is shown on the left. Deducd genotypes are shown in brackets. Recombinants between HPT and each locus, observed in the affected males, carrier females, and unaffected males, are indicated by an asterisk. Thus, in family W/81, III. 6, III. 13, IV. 1, IV. 7, IV. 10, IV. 11, V. 1, and V. 3, and in family P/60, IV. 10, show recombinants between HPT and the X linked polymorphic loci; these recombinants located HPT in the interval telomeric to F9 and centromeric to DXS984.

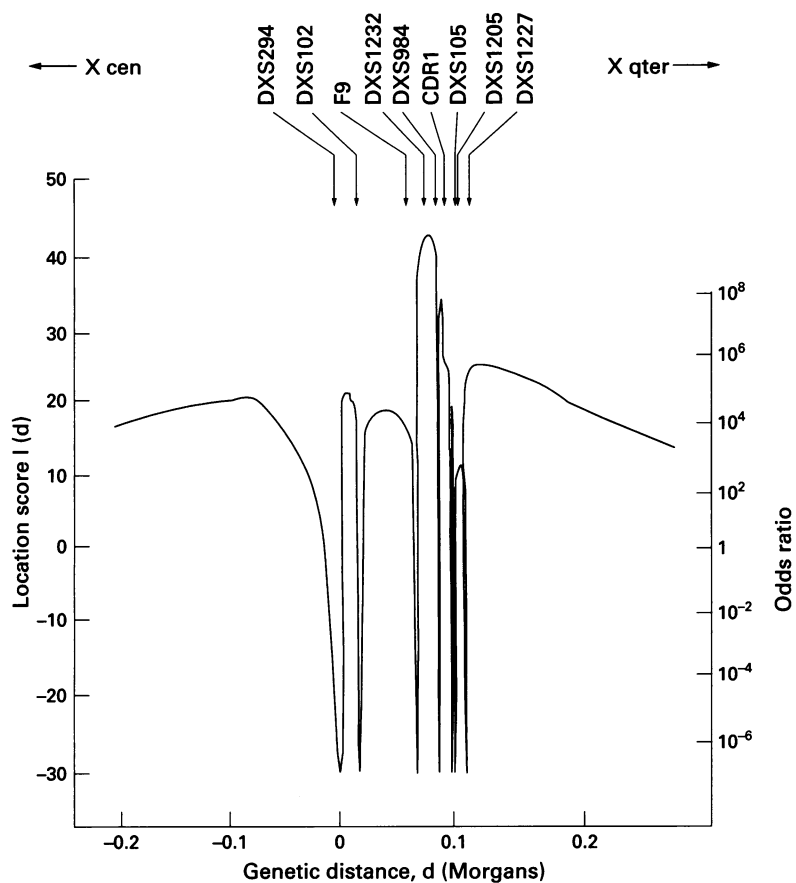

Figure 2 Location scores of HPT versus nine polymorphic loci from Xq26-Xq27. The horizontal axis is the genetic distance ( $d$ ) in Morgans from DXS984 which has been taken as the arbitrary origin. The right vertical axis is the odds ratio for the location of HPT at a given distance compared with a location of HPT at an infinite distance from the nine fixed loci. The left axis is the location score,  $l(d)$ , defined as twice the natural logarithm of the odds ratio. A location of HPT between F9 and DXS984 was favoured over all the other locations (table 2).

in an X linked recessive manner in five or more generations and in whom linkage between the disease and the Xq26-q27 locus DXS98 had been established,<sup>10</sup> were investigated. The family reported by Peden<sup>8</sup> in 1960 was designated P/60 and that reported by Whyte and Weldon<sup>9</sup> in 1981 was designated family W/81 (fig 1). Venous blood was obtained, after informed consent, from 61 family members (six affected males, 11 carrier females, and 44 unaffected (16 males, 28 females) subjects).

#### GENETIC MARKERS

Leucocyte DNA was prepared from venous blood samples and used to detect restriction fragment length polymorphisms (RFLPs) and polymorphisms in microsatellite tandem repeats, as previously described.<sup>10, 19</sup> The six loci DXS294, F9, CDR, DXS105, DXS98, and DXS52 defined RFLPs and the six loci DXS1001, DXS102, DXS1232, DXS984, DXS1205, and DXS1227 defined microsatellite polymorphisms (GenBank).

#### LINKAGE ANALYSIS

The data from the present and previously reported study<sup>10</sup> of both the families, which were established by mitochondrial DNA analysis to be related,<sup>17</sup> were pooled for linkage studies. Conventional two point lod scores and multipoint location scores were calculated using the LINKAGE computer programs, ver-

sion 5.1, on a 64 megabyte RAM Sun 4-90 computer running Sun OS4.1.1 as described.<sup>10</sup> The fixed order of loci and the genetic distances between the respective intervals required for multilocus analysis were deduced from published genetic maps,<sup>20-23</sup> and the order of loci was taken as Xcen - DXS1001 - DXS294 - DXS102 - F9 - DXS1232 - DXS984 - CDR1 - DXS105 - DXS1205 - DXS1227 - DXS98 - DXS52 - Xqter.<sup>24</sup> The frequency of HPT was estimated to be  $10^{-4}$  and the allele frequencies of the polymorphisms were obtained from the published genetic maps (GenBank). Varying the disease or allele frequencies had no effect on the results of the linkage analysis. Multipoint crossovers were analysed to determine the order of loci around HPT using a fixed framework of markers, as previously described.<sup>10</sup> The likelihood for each position of HPT within the fixed framework of genetic markers was expressed as a location score, which was twice the natural logarithm of the odds ratio. The probability of the most likely locus order and the relative likelihood of other orders were then ascertained from this location score curve, as previously described.<sup>10</sup>

#### Results

Eleven of the 12 polymorphic markers, whose order in Xq26-q27 has been established as Xcen - DXS1001 - DXS294 - DXS102 - F9 - DXS1232 - DXS984 - CDR1 - DXS105 - DXS1205 - DXS1227 - DXS98 - DXS52 - Xqter,<sup>24, 25</sup> proved informative in the two HPT families. An examination of the haplotypes within the 21 cM interval flanked centromerically by DXS1001 and telomerically by DXS105 showed a haplotype (6, A, 2, B, 2, 4, D, E) that was shared between the two oldest carrier females (II.2 in family W/81 and III.2 in family P/60). This finding further supports the relatedness of the two families and is consistent with the results of our mitochondrial genome analysis<sup>17</sup> that established a common ancestry for these two families from eastern Missouri. The data from the two families were therefore pooled for linkage analysis.

Linkage between HPT and eight of the 12 polymorphic loci (table 1) from Xq26-27 was established with the highest peak lod score of 7.06 at a recombination fraction ( $\theta$ )=0.05 (95% confidence interval=0.001 to 0.15) being obtained between DXS984 and HPT. These results helped to confirm the previous localisation<sup>10</sup> of HPT to this region, which was on the basis of linkage (lod score=3.82) to only one marker, DXS98. Analysis of individual recombinants (fig 1) helped to define the region containing the HPT locus further. In family W/81, HPT is segregating in the eight affected or carrier subjects II.2, III.2, III.9, III.16, III.18, IV.4, IV.9, and V.2 with the haplotype (6, A, 2, B, 2, 4, D, E, 3, 1, g, 3) defined by the loci DXS1001, DXS294, DXS102, F9, DXS1232, DXS984, CDR1, DXS105, DXS1205, DXS1227, DXS98, and DXS52, respectively. However, in the remaining four affected or carrier subjects (III.13, IV.15, V.1, and V.3), recombinants are observed and these locate HPT in a 19 cM interval between F9 and

Table 1 Lod scores for linkage of markers from Xq26-q27 and hypoparathyroidism

Locus	Peak		Lod scores Z( $\theta$ )							
	Z( $\theta$ )	$\theta$	Z(0.001)	Z(0.01)	Z(0.05)	Z(0.10)	Z(0.15)	Z(0.20)	Z(0.25)	Z(0.30)
DXS1001	2.24	0.15	-4.65	-0.76	1.55	2.15	2.24	2.12	1.88	1.56
DXS294	3.40	0.05	2.08	3.02	3.40	2.76	3.00	2.64	2.20	1.74
DXS102	4.24	0.05	1.44	3.33	4.24	4.21	3.92	3.51	3.03	2.50
F9*	2.02	0.10	-1.25	0.69	1.79	2.02	1.99	1.85	1.64	1.38
DXS1232	1.58	0.00	1.58	1.54	1.39	1.20	1.02	0.84	0.67	0.52
DXS984	7.06	0.05	6.10	6.97	7.06	6.58	5.95	5.24	4.47	3.65
CDR1	3.61	0.00	3.61	3.54	3.30	2.96	2.62	2.27	1.92	1.56
DXS105	6.23	0.05	5.24	6.11	6.23	5.79	5.20	4.53	3.82	3.10
DXS1205	4.58	0.05	1.86	3.74	4.58	4.48	4.10	3.60	3.03	2.42
DXS1227	4.03	0.05	1.32	3.19	4.03	3.91	3.52	3.02	2.45	1.85
DXS98*	3.40	0.05	2.08	3.02	3.40	3.28	3.00	2.64	2.21	1.74
DXS52*	2.49	0.15	-4.45	-0.56	1.78	2.39	2.49	2.38	2.14	1.81

\*The previously published<sup>10</sup> data for F9, DXS98, and DXS52 were pooled with the present data.

DXS52. A comparison of the haplotypes observed in the affected and carrier subjects between families W/81 and P/60, which have a common ancestry,<sup>17</sup> shows a recombination between HPT and the telomeric loci DXS1205, DXS1227, DXS98, and DXS52. The combined results from all of these recombinants in affected males and carrier females locates HPT in the 5 cM interval between F9 and DXS1205. The recombinant observed in the unaffected male IV.11 from family W/81 helps to narrow the limits of the region containing HPT further. IV.11 has the affected haplotype at the telomeric loci DXS984, CDR1, DXS1205, DXS1227, DXS98, and DXS52 but remains unaffected, thereby indicating a location for HPT that is centromeric to DXS984. Thus, the results of these recombinants indicate that HPT is located between F9 and DXS1205, a region of 5 cM, which can be narrowed further to a 2.5 cM interval by taking into account the recombinant observed in the unaffected subject IV.11. The likelihood of this location of HPT within the fixed order Xcen - DXS294 - DXS102 - F9 - DXS1232 - DXS984 - CDR1 - DXS105 - DXS1205 - DXS1227 - Xqter was quantitatively assessed using the LINKMAP program. Analysis using the LINKMAP program yielded the location score curve shown in fig 2. There is a high peak telomeric to F9 and centromeric to DXS984, maximum location score=42.8, 1.1 cM telomeric to F9. This coincides with the location of DXS1232 which showed no recombination with HPT. There are seven subsidiary peaks with location scores ranging from 11.7 to 33.8 (table 2). An analysis of these indicates that the odds ratio favouring the order Xcen - DXS294 - DXS102 - F9 - (HPT, DXS1232) - DXS984 - CDR1 - DXS105 - DXS1205 - DXS1227 - Xqter versus a location of HPT unlinked to this cluster of nine loci is  $>1.3 \times 10^9:1$  (table 2). In addition, the odds ratio favouring other locations of HPT within this framework of nine loci is also significant. However, a location of HPT telomeric as opposed to

centromeric to F9 is approximately 34 000 times more likely, and a location of HPT centromeric as opposed to telomeric to DXS984 is approximately 60 times more likely. These results indicate that HPT maps between F9 and DXS984, an interval that is estimated by genetic mapping to be 2.5 cM in size and by physical mapping to be 1.5 Mbp in size.<sup>25</sup>

### Discussion

Our location of the HPT gene to a 1.5 Mbp region between F9 and DXS984 considerably advances the search for this putative developmental gene. However, it is important to note that the location of HPT centromeric to DXS984 is only 60 times more likely than telomeric, and thus this interval may possibly be larger. The interval between F9 and DXS984 is contained within a YAC contig<sup>25 26</sup> and three candidate genes, represented by SOX3,<sup>27 28</sup> MCF.2,<sup>29</sup> and the expressed sequence tag (EST) AS6,<sup>25</sup> have been mapped to this region. SOX3 represents a member of the SRY family of developmental genes and MCF.2 is a member of the guanine nucleotide exchange factors for the RHO family of small GTP binding proteins. Investigation of these candidate genes for mutations in the HPT patients will help to elucidate their roles in the aetiology of this disorder of parathyroid gland development. However, such an analysis may require cautious interpretation as patients with deletions of this region<sup>24 25 30</sup> have not been reported to suffer from hypocalcaemia or hypoparathyroidism; such patients have been identified as they have deletions of F9 that extend into this region to include DXS98, and they suffer from haemophilia B (Christmas disease).

There may be at least three possible explanations for these contradicting observations from the deletion mapping studies in haemophilia B patients and our linkage mapping of HPT. First, in the haemophilia B patient with a loss of this region, there may be a non-contiguous deletion with preservation of the HPT gene. However,

Table 2 Order of genetic loci and their respective odds ratios as calculated from multipoint linkage analysis

Locus order	Peak location score	Odds ratio
Xcen-DXS294-HPT-DXS102-FIX-DXS1232-DXS984-CDR1-DXS105-DXS1205-DXS1227-Xqter	21.1	$3.8 \times 10^4$
Xcen-DXS294-DXS102-HPT-FIX-DXS1232-DXS984-CDR1-DXS105-DXS1205-DXS1227-Xqter	18.9	$1.3 \times 10^4$
Xcen-DXS294-DXS102-FIX-(HPT-DXS1232)-DXS984-CDR1-DXS105-DXS1205-DXS1227-Xqter	42.8	$1.3 \times 10^9$
Xcen-DXS294-DXS102-FIX-DXS1232-DXS984-HPT-CDR1-DXS105-DXS1205-DXS1227-Xqter	33.8	$2.2 \times 10^7$
Xcen-DXS294-DXS102-FIX-DXS1232-DXS984-CDR1-DXS105-HPT-DXS1205-DXS1227-Xqter	19.3	$1.6 \times 10^4$
Xcen-DXS294-DXS102-FIX-DXS1232-DXS984-CDR1-DXS105-DXS1205-HPT-DXS1227-Xqter	11.7	$3.5 \times 10^2$

this seems unlikely as the 11 STSs, which include those for SOX3, MCF.2, and AS6, are all deleted.<sup>25, 26</sup> Second, there may be a complex mode of diallelic inheritance for HPT that requires mutations in two (or more) different genes. Such diallelic inheritance has been described for retinitis pigmentosa (RP) in three families.<sup>31</sup> However, the high lod scores we observed in the HPT kindred(s) make this possibility unlikely, as digenic or polygenic inheritance would reduce the lod scores by inclusion of subjects who have the requisite mutations in only one of the necessary genes. Third, instead of a functional loss, the aetiology of HPT may involve a gain of function owing to an activating mutation. Thus, patients with deletions of the gene, for example, the haemophilia B patients, would be either unaffected or have a phenotype different from HPT. Such activating mutations involving the calcium sensing receptor gene, which is located on chromosome 3q21-q24,<sup>15</sup> have been reported to result in a form of hypoparathyroidism.<sup>13</sup> In addition, such gain of function mutations could involve a duplication and it is important to note that X linked genes are particularly likely to show dose dependent effects and that the differentiation of organs is sensitive to the prevailing concentrations of morphogenetic factors.<sup>32</sup> Interestingly, a regional duplication in Xq25-q26 involving DXS102, which is located centromeric to F9, has been observed in a family with X linked recessive panhypopituitarism, and it is postulated that this gene may encode for a dosage sensitive protein that is of importance in the development of the pituitary.<sup>33</sup> The situation in X linked recessive hypoparathyroidism may be analogous, but it is important to note that our analysis of the 11 STSs from this region has not indicated evidence for such a duplication, and it may be that this possibility is also unlikely or that the duplication is of a small size and has therefore not been detected by the current markers.

The characterisation of the HPT gene, which represents a putative parathyroid gland developmental gene located in Xq26-Xq27, will help to elucidate these possibilities. These studies will be facilitated by our results which have rendered the target region small enough for a complete DNA sequence analysis. This will enable the direct analysis of this region for gene content, rare mutations, and duplications and thus help to elucidate the role of this gene in the embryological formation of the parathyroid glands.

We are grateful for support from the Medical Research Council (MRC), UK (DT, PHD, CW, and RVT); grant No NIH-G00247 from the National Institutes of Health, USA (SM and DS); and grant No 15958 from The Shriners Hospital for Children (MPW). SM is supported by a fellowship from the Shriners Hospital for Children, DT was an MRC Training Fellow, and PHD is an MRC PhD student.

- 1 Thakker RV. Molecular genetics of hypoparathyroidism. In: Bilezikian JP, Levine MA, Marcus R, eds. *The parathyroids*. New York: Raven Press, 1994:765-79.
- 2 Whyte MP. Autoimmune aspects of hypoparathyroidism. In: Bilezikian JP, Levine MA, Marcus R, eds. *The parathyroids*. New York: Raven Press, 1994:753-64.
- 3 Ahn TG, Antonarakis SE, Kronenberg HM, Igarashi T, Levine MA. Familial isolated hypoparathyroidism: a molecular genetic analysis of 8 families with 23 affected persons. *Medicine* 1986;65:73-81.
- 4 Barr DGD, Prader A, Esper U, Rampini S, Marrian VJ, Forfar JO. Chronic hypoparathyroidism in two generations. *Helv Paediatr Acta* 1971;26:507-21.
- 5 Arnold A, Horst SA, Gardella TJ, Baba H, Levine MA, Kronenberg HM. Mutation of the signal peptide-encoding region of the preproparathyroid hormone gene in familial isolated hypoparathyroidism. *J Clin Invest* 1990;86:1084-7.
- 6 Bronsky D, Kiamliko RT, Waldstein SS. Familial idiopathic hypoparathyroidism. *J Clin Endocrinol Metab* 1968;28:61-5.
- 7 Parkinson DB, Thakker RV. A donor splice site mutation in the parathyroid hormone gene is associated with autosomal recessive hypoparathyroidism. *Nat Genet* 1992;1:149-52.
- 8 Peden VH. True idiopathic hypoparathyroidism as a sex linked recessive trait. *Am J Hum Genet* 1960;12:322-37.
- 9 Whyte MP, Weldon VV. Idiopathic hypoparathyroidism presenting with seizures during infancy: X-linked recessive inheritance in a large Missouri kindred. *J Pediatr* 1981;99:608-11.
- 10 Thakker RV, Davies KE, Whyte MP, Wooding C, O'Riordan JLH. Mapping of the gene causing X-linked recessive idiopathic hypoparathyroidism to Xq26-Xq27 by linkage studies. *J Clin Invest* 1990;86:40-5.
- 11 Mayer H, Breyel E, Bostock C, Schmitte J. Assignment of the human parathyroid hormone gene to chromosome 11. *Hum Genet* 1983;64:283-5.
- 12 Naylor SL, Sakaguchi AY, Szoka P, et al. Human parathyroid hormone gene (PTH) is on the short arm of chromosome 11. *Som Cell Genet* 1983;9:609-16.
- 13 Pearce SHS, Williamson C, Kifor O, et al. A familial syndrome of hypocalcaemia with hypercalciuria due to mutations in the calcium-sensing receptor. *N Engl J Med* 1996;335:1115-22.
- 14 Baron J, Winer KK, Yanovski JA, et al. Mutations in the human Ca<sup>2+</sup>-sensing receptor gene cause autosomal dominant and sporadic hypoparathyroidism. *Hum Mol Genet* 1996;5:601-6.
- 15 Pollak MR, Brown EM, Chou YHW, et al. Mutations in the human Ca<sup>2+</sup>-sensing receptor gene cause familial hypocalcaemic hypercalcaemia and neonatal severe hyperparathyroidism. *Cell* 1993;75:1297-303.
- 16 Whyte MP, Kim GS, Kosanovich M. Absence of parathyroid tissue in sex-linked recessive hypoparathyroidism. *J Pediatr* 1986;109:915.
- 17 Mumm S, Whyte MP, Thakker RV, Buetow KH, Schlessinger D. MtDNA analysis shows common ancestry in two kindreds with X-linked recessive hypoparathyroidism and reveals a heteroplasmic silent mutation. *Am J Hum Genet* 1997;60:153-9.
- 18 Collins FS. Positional cloning: let's not call it reverse any more. *Nat Genet* 1992;1:3-6.
- 19 Pang JT, Lloyd SE, Wooding C, et al. Genetic mapping studies of 40 loci and 23 cosmids in chromosome 11p13-11q13, and exclusion of mu-calpain as the multiple endocrine neoplasia type 1 gene. *Hum Genet* 1996;97:732-41.
- 20 Suthers GK, Oberle I, Nancarrow J, et al. Genetic mapping of new RFLPs at Xq27-Xq28. *Genomics* 1991;9:37-43.
- 21 NIH/CEPH Collaborative Mapping Group. A comprehensive genetic linkage map of the human genome. *Science* 1992;258:67-86.
- 22 Malmgren H, Sundvall M, Dahl N, et al. Linkage mapping of a severe X-linked mental retardation syndrome. *Am J Hum Genet* 1993;52:1046-52.
- 23 Gyapay G, Morissette J, Vignal A, et al. The 1993-1994 Genethon human genetic linkage map. *Nat Genet* 1994;7:246-339.
- 24 Willard HF, Cremers F, Mandel JL, Monaco AP, Nelson DL, Schlessinger D. Report of the fifth international workshop on human X chromosome mapping 1994. *Cytogenet Cell Genet* 1994;67:295-358.
- 25 Zucchi I, Mumm S, Pilia G, et al. YAC/STS map across 12 Mb of Xq27 at 25-kb resolution, merging Xq26-qter. *Genomics* 1996;34:42-54.
- 26 Pilia G, Macmillian S, Nagarajah R, Mumm S, Weissenbach J, Schlessinger D. YAC/STS map of Xq26 at 100 kb resolution, localising 6 ESTs, 6 genes and 32 genetic markers. *Genomics* 1996;34:55-62.
- 27 Stevanovic M, Lovell-Badge R, Collignon J, Goodfellow PN. SOX3 is an X-linked gene related to SRY. *Hum Mol Genet* 1993;2:2013-18.
- 28 Mumm S, Zucchi I, Pilia G. SOX3 gene maps near DXS984 in Xq27.1, within candidate regions for several X-linked disorders. *Am J Med Genet* 1997;72:376-8.
- 29 Ron D, Tronick SR, Aaronson SA, Eva A. Molecular cloning and characterization of the human db1 proto-oncogene: evidence that its overexpression is sufficient to transform NIH/3T3 cells. *EMBO J* 1988;7:2465-73.
- 30 Davies KE, Mandel JL, Monaco AP, Nussbaum RL, Willard HF. Report of the committee on the genetic constitution of the X chromosome. *Cytogenet Cell Genet* 1992;58:853-956.
- 31 Kajiwara K, Berson EL, Dryja TP. Digenic retinitis pigmentosa due to mutations at the unlinked peripherin/RDS and ROM1 loci. *Science* 1994;264:1604-7.
- 32 Sharkey M, Graba Y, Scott, MP. Hox genes in evolution: protein surfaces and paralog groups. *Trends Genet* 1997;13:145-51.
- 33 Lagerstrom-Fermer M, Sundvall M, Johnsen E, et al. X-linked recessive panhypopituitarism associated with a regional duplication in Xq25-26. *Am J Hum Genet* 1997;60:910-16.