

Plasmalemma Redox Activity and H⁺ Extrusion

I. ACTIVATION OF THE H⁺-PUMP BY FERRICYANIDE-INDUCED POTENTIAL DEPolarIZATION AND CYTOPLASM ACIDIFICATION

Received for publication August 4, 1987 and in revised form December 1, 1987

MARIA TERESA MARRÈ, ANNA MORONI, FRANCESCO G. ALBERGONI, AND ERASMO MARRÈ*
Centro del CNR per la Biologia Cellulare e Molecolare delle Piante, Department of Biology, University of Milano, Via Celoria 26, 20133 Milano, Italy

ABSTRACT

Ferricyanide reduction by *Elodea densa* leaves, in the dark, is associated with: (a) acidification of the medium; (b) decrease (about 0.2–0.3 units) of intracellular pH (measured in cell sap, cytoplasm, and vacuole); (c) depolarization of the transmembrane potential; (d) net efflux of K⁺ to the medium. Ferricyanide-induced acid secretion is markedly increased by the presence of fusicoccin (FC), and this effect is severely inhibited by the proton pump inhibitors erythrosine B and vanadate. In the presence of ferricyanide FC-induced H⁺ extrusion no longer requires the presence of K⁺ in the medium. The (ferricyanide reduced)/(H⁺ extruded) ratio varies from about 2, in the absence of FC, to about 1 when the toxin is present, and to more than 4, when ATP-driven H⁺ extrusion is inhibited by erythrosine B or by vanadate. Fusicoccin markedly reduces K⁺ release to the medium. The ratio (ferricyanide reduced)/(H⁺ extruded + K⁺ released) approaches unity under all of the three conditions considered. These results indicate that ferricyanide reduction depends on a plasmalemma system transporting only electrons to the extracellular acceptor, with consequent potential depolarization and cytoplasm acidification. Most of the protons released in the cytoplasm would be secondarily extruded by the ATP-driven pump, stimulated by both intracellular acidification and depolarization. K⁺ efflux would depend on potential depolarization.

Recent evidence demonstrates in plants the operation of a plasmalemma redox system transporting reducing equivalents from intracellular substrates to extracellular electron acceptors such as ferricyanide and ferric ion. The finding that ferricyanide reduction is associated with the acidification of the extracellular medium suggested a possible role of this system in ion transport across the plasma membrane, and in particular in H⁺ extrusion (6, 11, 12, 14, 18, 29). H⁺ extrusion in the presence of ferricyanide might occur at the level of the redox chain, similarly to that known for the mitochondria and thylakoid membranes: then the plasmalemma redox chain would represent a mechanism of H⁺ extrusion alternate to the better known ATP-driven proton pump (14, 23). A second possibility is that the reducing agent at the external plasma membrane surface is of the XH₂/X type, which would donate electrons to Fe(CN)₆³⁻ and release H⁺ into the medium (3, 6). According to a third, alternative interpretation the electron transport to ferricyanide would activate the ATP driven pump, which would be the main mechanism responsible for H⁺ extrusion (17, 27).

In an attempt to discriminate between these alternatives we assumed that they might result in a different behavior of the intracellular pH. The direct extrusion of H⁺ by the redox system should not influence cytoplasmic pH, inasmuch as the two hy-

drogen atoms (2 electrons + 2 protons) coming from the oxidation of a respiratory substrate (XH₂ to X) would be transported out of the cell: the two electrons would reduce two ferricyanide molecules and the two protons would be secreted as such into the extracellular medium. In contrast, the model coupling the electron efflux by the redox system with the extrusion of protons by the ATP-driven pump would implicate at least an initial acidification of the cytoplasm by the H⁺ released in the cytosol during the transport of electrons to ferricyanide. This acidification would then be partially compensated by a secondary increase in activity of the ATP driven H⁺ pump. Thus, we measured the changes in intracellular pH (in cell sap, 'bulk cytoplasm' and vacuole; 1, 2, 22) associated with ferricyanide reduction and acidification of the external medium.

The relative roles of the redox chain and of the H⁺ pump in ferricyanide-induced H⁺ extrusion were investigated by influencing the activity of ATP-driven H⁺ extrusion. As an activator of the ATP-driven pump we used fusicoccin (recently shown to stimulate ATP-dependent electrogenic H⁺ transport in plasmalemma preparations; 24, 25). To inhibit the pump, we used erythrosine B and vanadate, two relatively specific inhibitors of the H⁺-ATPase of plasmalemma (10), both very active on H⁺ extrusion *in vivo* in *Elodea* leaves (19).

As a plant material we chose *Elodea densa* leaves, very active in reducing ferricyanide (14) and also endowed with an efficient mechanism of electrogenic H⁺ extrusion, presumably depending on the operation of the ATP-driven fusicoccin-stimulated and vanadate-inhibited H⁺ pump (1, 19).

All experiments were carried out in the dark, in order to avoid the interference of light, which influences by a yet unknown mechanism both electrogenic H⁺ extrusion by the H⁺ pump and ferricyanide reduction (2).

MATERIALS AND METHODS

Elodea densa. Plants were cultured in a greenhouse in large tanks, about 0.4 m³ in volume, containing a 20 cm thick layer of soil, and with continuous water flux of about 30 L/h. The flowing water (from the local aqueduct) contained approximately 10⁻³ M Cl⁻, 10⁻³ M SO₄²⁻, 2 × 10⁻⁴ M NO₃⁻, 10⁻⁶ M PO₄³⁻, 1.6 × 10⁻³ M Ca²⁺, 8 × 10⁻⁴ M Mg²⁺, 8 × 10⁻⁴ M K⁺, 2 × 10⁻⁷ M Fe³⁺. Growth in these conditions was quite satisfactory, and development of epiphytic organisms (mainly diatoms) was minimal. No symptoms of iron (or other micronutrient) deficiency were observed. For the experiments, actively growing shoots (about 5 cm long) were excised and preincubated overnight in the dark in 0.5 mM CaSO₄. The leaves were excised, randomized, and preincubated for 2 h in 0.5 mM CaSO₄ in the light (70 W m⁻²) at 20°C in agitated Erlenmeyer flasks (40 leaves = 300 mg fresh weight in 20 ml) and then treated in the dark

as described for each experiment. FC,¹ EB, and vanadate, when present, were added in the last half-hour of pretreatment.

H⁺ Extrusion and Ferricyanide Reduction. After the pretreatment the samples (300 mg fresh weight/20 ml) were transferred into a solution containing 0.5 mM CaSO₄, 0.5 mM Mes, with and without 1 mM K₃Fe(CN)₆, with or without 1.5 mM K₂SO₄. The pH was adjusted to 6 with BTP. Proton extrusion was measured after 90 min by back-titration of the medium after removal of CO₂ according to Lado *et al.* (16). Ferricyanide reduction was measured spectrophotometrically by the decrease in A₄₂₀. Measurements of the ferricyanide accumulated in the medium by reoxidizing it with H₂O₂ showed that it stoichiometrically corresponded to the observed decrease in Fe(CN)₆³⁻. No accumulation of either Fe(CN)₆³⁻ or Fe(CN)₆⁴⁻ in the washed tissue at the end of incubation was detected. Leakage of soluble Fe(CN)₆³⁻-reducing compounds was ruled out by finding that no reduction takes place when Fe(CN)₆³⁻ is added to a medium where the leaves have been previously incubated for 2 h. In the experiments in which K⁺ was absent, K₃Fe(CN)₆ had previously been transformed into the BTP salt by passing the K⁺ salt solution through a AG-50W-X8 (Bio-Rad) cation exchange resin, followed by measurements of the K⁺ contents and the ferricyanide concentration in the final solution.

K⁺ Release to Medium. This was calculated from the change in K⁺ concentration in the medium measured by atomic absorption spectrophotometry (Varian Techtron AA 1275).

Cell Sap pH. At the end of the treatments the leaves were washed in distilled water, blotted on filter paper, transferred into plastic syringes and frozen at -30°C for at least 3 h. After freezing and thawing the cell sap (about 0.2 ml) was pressed out of the syringe and the pH was measured by means of a Radiometer pHmeter equipped with a flat tip electrode (Ingold 40424, lot 403-30-M8).

Measurements of Vacuolar and Cytoplasmic pH by Weak Base and Weak Acid Distribution Method. Vacuolar pH was calculated from the distribution of benzylamine at equilibration; the value thus obtained was then used in the calculation of 'bulk cytoplasm' pH from the values of DMO distribution, according to the previously described procedure (19, 20). The reliability of the weak acid distribution method for the measurement of FC- and K⁺-induced intracellular pH changes in *Elodea densa* leaves has been recently confirmed by parallel measurements with the ³¹P-NMR method (J Guern, Y Mathieu, MT Marrè, E Marrè, unpublished data).

Transmembrane Electrical Potential Difference. Measurements of E_m were performed in the dark by the conventional microelectrode procedure described by Cocucci *et al.* (9). Ferricyanide induced-PD changes were corrected for tip potential (about 15 mV).

All experiments were run in triplicate, and repeated at least three times. The data presented are those of an experiment taken as typical for each experimental treatment, where the standard error did not exceed ±6%.

RESULTS

Effects of Fusicoccin, K⁺, Erythrosine B and Vanadate on Ferricyanide Reduction and Apparent H⁺ Extrusion. The data of Table I show that the reduction of ferricyanide by isolated *Elodea* leaves, in the dark, was associated with a marked increase in titratable acidity of the medium. This acidification was not sig-

Table I. Effects of FC, K⁺, Erythrosine B, and Vanadate on Ferricyanide Reduction (e⁻) and Apparent H⁺ Extrusion (-ΔH⁺)

Incubation in 0.5 mM Mes/BTP buffer (pH 6), 0.5 mM CaSO₄, ±1 mM Fe(CN)₆³⁻, ±1.5 mM K₂SO₄, ±10⁻⁴ M FC, ±10⁻⁴ M EB, ±10⁻⁴ M Na vanadate. SE was less than ±6%.

Additive	-ΔH ⁺		e ⁻	e ⁻ /-ΔH ⁺
	Control Fe(CN) ₆ ³⁻			
	μmol/g fresh wt · 90 min			ratio
Control	0.1	13.4	28.3	2.1
K ⁺	2.1	13.9	25.1	1.8
FC	2.3	27.8	36.2	1.3
K ⁺ + FC	14.6	29.7	35.7	1.2
K ⁺ + EB	0.5	2.8	24.5	8.7
K ⁺ + FC + EB	3.5	4.5	29.0	6.4
Control + vanadate		5.4	29.0	5.4
FC + vanadate		6.1	28.0	4.6

nificantly influenced by the presence of K⁺ in the medium, which in contrast markedly stimulated H⁺ extrusion in the absence of ferricyanide. FC, a well known activator of the ATP-driven H⁺ pump, strongly increased the amount of protons extruded when Fe³⁺ was present. Here again, this effect was not significantly influenced by the presence of K⁺ in the medium, in contrast with the strict requirement for this cation observed for the effect of FC on H⁺ extrusion when ferricyanide was not present (20, 21). FC (with or without K⁺) also induced some increase in ferricyanide reduction, in agreement with previous observations on other materials (11, 12, 17). The simulation of ferricyanide reduction by FC in *Elodea* showed a marked variability from experiment to experiment (presumably depending on some undefined condition of the material), ranging from about 10 to 70%.

The data of Table I also show that erythrosine B, a powerful inhibitor of plasmalemma ATPase *in vitro* and of fusicoccin- and K⁺-induced H⁺ extrusion *in vivo* (10), severely inhibited ferricyanide-induced acidification of the medium, while it only slightly influenced ferricyanide reduction. A similar although somewhat smaller effect was induced by vanadate, which in *Elodea* is less effective than erythrosine in inhibiting H⁺ extrusion. This suggests that the two processes involve distinct mechanisms (for a similar conclusion see Ref. 27).

The last column of Table I shows that the (ferricyanide reduced)/(protons extruded) ratio (e⁻/H⁺) was about 2, in the absence of fusicoccin, decreased to about 1.2 with fusicoccin (*i.e.* when the H⁺ pump was stimulated by the toxin) and rose to much higher values with erythrosine B and with vanadate (*i.e.* when the H⁺ pump was strongly inhibited). This confirms that ferricyanide reduction can be dissociated to a very large extent from the release of H⁺ into the medium.

Effects of Ferricyanide on K⁺ Transport and on E_m. The finding of e⁻/H⁺ ratios well above unity raises the question of how the electroneutrality of the medium is maintained: in fact, the number of negative charges transported as electrons on ferricyanide should be matched by an equal number of net positive charges appearing in the medium, either as net release of cations to the medium or net influx of anions. The data of Table I show that this requirement was only partially fulfilled by H⁺ efflux. A reasonable hypothesis would be that the difference to reach a e⁻/H⁺ ratio of 1 was made up by K⁺ release to the medium, as recently reported by Lass *et al.* (17) in *Lemna*. The data of Table II show that this was the case also in *Elodea*, where K⁺ concentration in the medium, remaining extremely low in the controls, rose after 90 min of incubation with Fe(CN)₆³⁻ to about 8

¹ Abbreviations: FC, fusicoccin; BTP, 1,3-bis(tris[hydroxymethyl]methylamino)propane; -ΔH⁺, titratable H⁺ extrusion; -ΔK⁺, K⁺ increase in the incubation medium; DMO 5,5-dimethylloxazolidine-2,4 dione; EB, erythrosine B; E_m, transmembrane electrical potential difference; e⁻/H⁺, ferricyanide reduced/H⁺ extruded ratio.

Table II. Effect of Ferricyanide on K⁺ Release to the Medium (-ΔK⁺) and Stoichiometry of Ferricyanide Reduction and Total Cation Extrusion (-Δ[H⁺ + K⁺])

SE was less than ±5%. Leaves (300 mg fresh weight) were incubated for 90 min in 20 ml of 1 mM Mes/BTP buffer (pH 5.5), 0.5 mM CaSO₄, ± 1 mM Fe(CN)₆³⁻, ± 10⁻⁴ M FC.

	[K ⁺] in Medium at 90 min	-ΔH ⁺	-ΔK ⁺	Fe(CN) ₆ ³⁻ Reduced (e ⁻)	$\frac{e^-}{-\Delta(H^+ + K^+)}$
	M	μmol/g fresh wt · 90 min			ratio
Control	10 ⁻⁶	0.1	0.1		
Fe(CN) ₆ ³⁻	7.6 × 10 ⁻⁵	13.6	5.0	22.2	1.2
Fe(CN) ₆ ³⁻ + FC	3.0 × 10 ⁻⁵	23.5	2.0	29.11	1.1

× 10⁻⁵ M, in the absence of FC and to 3 × 10⁻⁵ M, in the presence of the toxin. This release of K⁺ seems related to the marked rapid depolarization of the transmembrane potential induced by ferricyanide, shown in Figure 1 (in agreement with the similar results, by Sijmons *et al.* (28, 29), by Ivankina *et al.* (14) in the same material and by Lass *et al.* (17) in *Lemna*; see also, for Fe(CN)₆³⁻-induced inhibition of K⁺ influx Kochian and Lucas (15) and Rubinstein and Stern (27), and for the stimulation of K⁺ efflux Kochian and Lucas (15).

Intracellular pH Changes Associated with Fe(CN)₆³⁻ Reduction. The above reported data suggest that ferricyanide reduction and medium acidification depend on two separate mechanisms: the primary transport of only electrons to ferricyanide, leading to the depolarization of the potential, and the secondary extrusion of protons by the ATP-driven, erythrosine- and vanadate-sensitive plasmalemma proton pump. If this is true, one would expect ferricyanide reduction to be associated with some acidification of the intracellular fluids. The data of Table III fully confirm this prediction, by showing that ferricyanide induced a significant acidification (of about 0.2 pH units) of the cell sap, efficiently opposing the alkalinizing action of K⁺ alone as well as that, much more marked, of K⁺ and FC together (for a detailed description and discussion of the effects of K⁺ and FC on intracellular pH in *Elodea* see Marrè *et al.* [19]).

It is interesting to observe from the data of Table III that the acidification by ferricyanide did not completely suppress the opposite alkalinization by (FC + K⁺), so that the pH of the cell

Table III. Changes of Cell Sap pH Associated with Ferricyanide Reduction

SE was less than ±0.02 pH units. Incubation for 90 min in 0.5 mM Mes/BTP buffer (pH 6), 0.5 mM CaSO₄, ± 1 mM Fe(CN)₆³⁻, ± FC 10⁻⁴ M.

Additive	Cell sap pH		Δ by Fe(CN) ₆ ³⁻
	Δ	Fe(CN) ₆ ³⁻ (Δ)	
Control	5.81	5.64	-0.17
K ⁺	6.00 (+0.19)	5.80 (+0.16)	-0.20
FC	5.91 (+0.10)	5.69 (+0.05)	-0.22
K ⁺ + FC	6.29 (+0.48)	6.08 (+0.24)	-0.21

sap was still significantly higher in the samples treated with (FC + K⁺) together with ferricyanide than in the controls where both factors were absent. This supports the hypothesis of the simultaneous operation of two distinct mechanisms, one of which would release protons within the cell, while the other would extrude them across the plasma membrane.

An evaluation of the pH changes in the vacuole and in the 'bulk cytoplasm' by the weak base (benzylamine)- weak acid (DMO) distribution method showed a significant decrease in the pH in both compartments, larger in the cytoplasm than in the vacuole (Fig. 2).

DISCUSSION

Taken as a whole, the results of this paper support and extend the model proposed by Rubinstein and Stern (27) inasmuch as they indicate a clear-cut separation between electron transport to ferricyanide by a plasmalemma redox system and H⁺ extrusion by the ATP-driven pump. As shown in the model of Figure 3 the linkage between these two systems would depend on the activity of the redox system in depolarizing the potential and in acidifying the cytoplasm. In fact, an activation of the H⁺ pump has been demonstrated *in vivo* in various materials as an effect of treatments either depolarizing the potential (5, 8, 21) or decreasing cytoplasmic pH (7, 13, 22, 26).

An implication of this model is that it would rule out the hypothesis that the redox system operates as a mechanism of H⁺ extrusion even in the absence of ferricyanide (or ferric ion) and with O₂ as a final electron acceptor. In fact, ferricyanide is known to accept electrons from a variety of electron carriers ranging from flavoproteins to cytochromes. Thus it seems reasonable to postulate that if the protons produced during the oxidation of an intracellular substrate are released in the cytoplasm when ferricyanide is the electron acceptor, this would happen also with oxygen as the physiological acceptor. If O₂ were reduced in the cytoplasm, the previously released protons would be used for H₂O formation, and no H⁺ transport at the plasma membrane

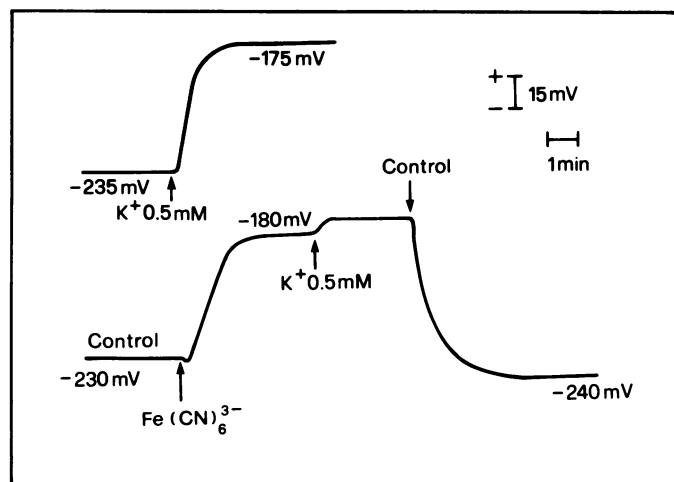

FIG. 1. Depolarization of the transmembrane potential by Fe(CN)₆³⁻ and lack of additivity of K⁺-induced with Fe(CN)₆³⁻-induced depolarization. Two leaves of *Elodea* were maintained in an aerated solution thermoregulated at 20°C (continuous flow, 15 ml/min) containing: 5 mM Mes/BTP buffer (pH 5.5), 5 × 10⁻⁶ M DCMU, 0.5 mM CaSO₄. Fe(CN)₆³⁻ was added at 1 mM concentration, K⁺ as 0.25 mM K₂SO₄.

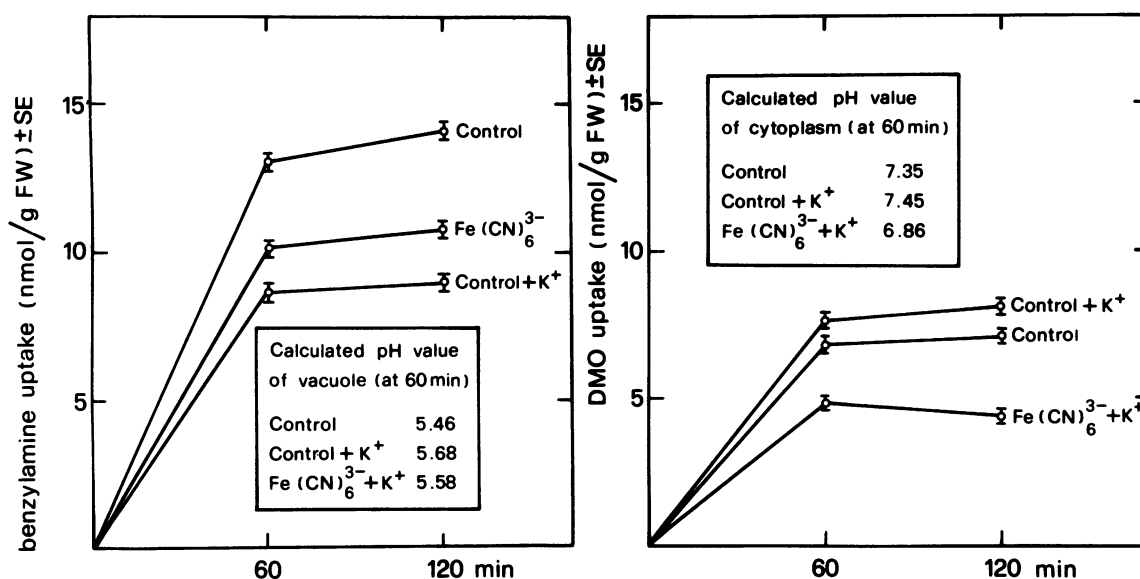

FIG. 2. Effects of $\text{Fe}(\text{CN})_6^{3-}$ on the uptake of benzylamine and DMO, and (in the inserts) calculated values of pH in the vacuole and in 'bulk cytoplasm.' The incubation mixtures contained: 0.5 mM CaSO_4 , 1.5 mM K_2SO_4 , 6×10^{-6} M DMO or 10^{-5} M benzylamine, 5×10^{-6} M DCMU (pH 5.8).

would take place. On the other hand, if O_2 were reduced by the redox chain at the external plasmalemma surface, H^+ concentration would decrease in the wall space, while it would increase in the cytoplasm: thus, the redox system would pump protons from the extracellular to the intracellular space, rather than extrude them!

The present results show that in *Elodea*, as previously reported for other materials (11, 12, 17), FC stimulated at some extent $\text{Fe}(\text{CN})_6^{3-}$ reduction. A direct effect of FC seems difficult to reconcile with the marked variability of this FC effect (from 10–70%, as mentioned in "Results"). In our opinion, a more likely and attractive hypothesis is that ferricyanide reduction is to some extent hindered (either thermodynamically or kinetically) by its direct products: *i.e.* the depolarization of the potential and the acidification of the cytoplasm. If this is true, the promotion of ferricyanide reduction by FC would be conveniently explained

by the activity of FC in hyperpolarizing the potential and in alkalinizing the cytoplasm, thus removing the negative feedback on the redox system by these two factors.

In addition to their bearing on the problem of the relationship between redox chain and H^+ extrusion, the present results are of interest as far as K^+ fluxes and their role in H^+ transport are concerned. The finding that the marked depolarization associated with $\text{Fe}(\text{CN})_6^{3-}$ reduction completely suppresses the strict requirement for K^+ by ATP-driven H^+ extrusion (with or without FC) suggests that K^+ action on H^+ extrusion mainly depends on its depolarizing activity, thus confirming that E_m contributes to the regulation of the activity of the H^+ pump (5, 8, 21). On the other hand, the very marked effect of ferricyanide in inducing K^+ release to the medium suggests that even in higher plants, as already demonstrated in algae, the decrease in E_m below a given threshold might 'open' some type of channel to passive K^+ transport (4). In fact, in *Elodea* leaves, ferricyanide-induced depolarization by about 50 mV (from -230 to -180 mV) is accompanied by an important net apparent efflux of K^+ , leading to a K^+ accumulation in the medium. A more detailed analysis of the relationships between K^+ fluxes, transmembrane potential, and intracellular pH is at present being conducted in this laboratory.

Acknowledgments—Thanks are due to Dr. Nicoletta Beffagna and Dr. Giulia Romani for the determination of cytoplasmic and vacuolar pH by the weak acid-weak base distribution method, and to Drs. Franca Rasi-Caldogno and Maria Ida De Michelis for critical reading of the manuscript and helpful discussion.

LITERATURE CITED

- ALBERGONI FG, MT MARRÈ, V TROCKNER, N BEFFAGNA, G ROMANI, E MARRÈ 1987 Changes of vacuolar and cytoplasmic pH associated with the activation of the H^+ pump in *Elodea* leaves. In BP Marin, ed, Plant Vacuoles. Their Importance in Plant Cell Compartmentation. NATO ASI Series, Plenum Publ. Corp., New York. In press
- ALBERGONI FG, MT MARRÈ, E MARRÈ 1987 Photosynthesis-induced activation of electrogenic H^+ extrusion in *Elodea densa* leaves. VII International Workshop on Plant Membrane Transport, Sydney, August 1986, In press
- BARR R, TA CRAIG, FL CRANE 1985 Transmembrane ferricyanide reduction in carrot cells. *Biochim Biophys Acta* 812: 49–54
- BELBY MJ 1985 Potassium channels at *Chara* plasmalemma. *J Exp Bot* 36: 228–239
- BELLANDO M, A TROTTA, A BONETTI, R COLOMBO, P LADO, E MARRÈ 1979

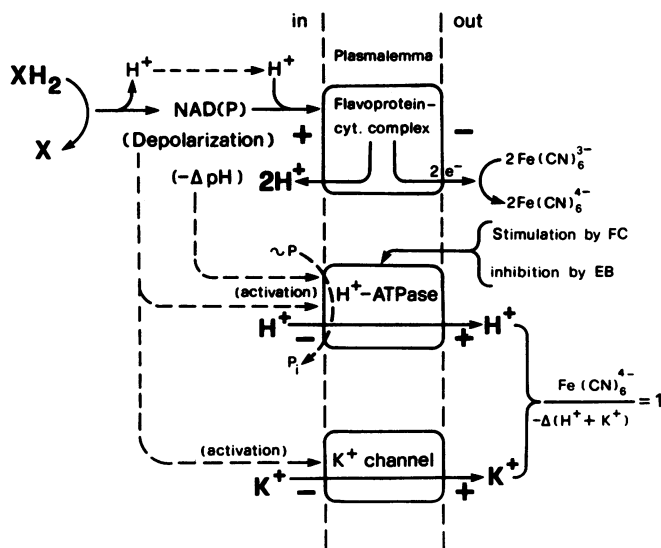

FIG. 3. Proposed model for electron and H^+ fluxes associated with ferricyanide reduction and for the relationships between plasmalemma redox system and ATP-driven H^+ extrusion.

- Dissociation of H⁺ extrusion from K⁺ uptake by means of lipophilic cations. *Plant Cell Environ* 2: 39–47
6. BÖTTGER M, M BIGDON, HJ SOLL 1985 Proton translocation in corn coleoptiles: ATPase or redox chain. *Planta* 163: 376–380
 7. BRUMMER B, H FELLE, RW PARISH 1984 Evidence that acid solutions induce plant cell elongation by acidifying the cytosol and stimulating the proton pump. *FEBS Lett* 174: 223–227
 8. CERANA R, A BONETTI, R COLOMBO, P LADO 1981 Tributylbenzylammonium (TBBA⁺)-dependent fusicoccin (FC)-induced H⁺ extrusion in maize roots: relationship between the stimulating effects of TBBA⁺ on H⁺ extrusion and on Cl⁻ efflux. *Planta* 152: 202–208
 9. COCUCCI M, E MARRÈ, A BALLARIN-DENTI, A SCACCHI 1976 Characteristics of fusicoccin-induced changes of transmembrane potential and ion uptake in maize root segments. *Plant Sci Lett* 6: 143–156
 10. COCUCCI MC, E MARRÈ 1986 Erythrosine B as an effective inhibitor of electrogenic H⁺ extrusion. *Plant Cell Environ* 9: 677–679
 11. CRAIG TA, FL CRANE 1982 Hormonal control of a transplasmamembrane electron transport system in plant cell. *Proc Ind Acad Sci* 91: 150–154
 12. FEDERICO R, CE GIARTOSIO 1983 A transplasmamembrane electron transport system in maize roots. *Plant Physiol* 73: 182–184
 13. HAGER, A, I MOSER 1985 Acetic acid esters and permeable weak acids induce active proton extrusion and extension growth of coleoptile segments by lowering the cytoplasmic pH. *Planta* 163: 391–400
 14. IVANKINA NG, VA NOVAK, AI MICLASHEVICH 1984 Redox reactions and active H⁺-transport in the plasmalemma of *Elodea* leaf cells. In WJ Cram, K Janacek, R Rybova, S Sigler, eds. *Membrane Transport in Plants*. John Wiley & Sons, Chichester, Sussex, England, pp 404–405
 15. KOCHIAN LV, WJ LUCAS 1985 Potassium transport in corn roots. III. Perturbation by exogenous NADH and ferricyanide. *Plant Physiol* 77: 429–436
 16. LADO P, R CERANA, A BONETTI, MT MARRÈ, E MARRÈ 1981 Effects of calmoduline inhibitors in plants. I. Synergism with fusicoccin in the stimulation of growth and H⁺ secretion and in hyperpolarization of the transmembrane electric potential. *Plant Sci Lett* 23: 253–262
 17. LASS B, G THIEL, CI ULLRICH-EBERIUS 1986 Electron transport across the plasmalemma of *Lemna gibba* G1. *Planta* 169: 251–259
 18. LIN W 1984 Further characterization of the transport property of plasmalemma NADH oxidation system in isolated corn root protoplasts. *Plant Physiol* 74: 219–222
 19. MARRÈ E, G ROMANI, N BEFFAGNA, V TROCKNER 1986 Intracellular pH alkalization associated with the fusicoccin- and K⁺-induced activation of the H⁺ pump in *Elodea densa* leaves. VIII International Workshop on Plant Membrane Transport. Sydney, August 1986. In press
 20. MARRÈ E, G ROMANI, N BEFFAGNA 1987 Potassium transport and regulation of intracellular pH in *Elodea densa* leaves. *Bot Acta* 101: 17–23
 21. MARRÈ MT, G ROMANI, M COCUCCI, MM MOLONEY, E MARRÈ 1982 Divalent cation influx, depolarization of the transmembrane electric potential and proton extrusion in maize root segments. In D Marmè, E Marrè, R Hertel, eds. *Plasmalemma and Tonoplast: Their Functions in the Plant Cell*. Elsevier Biomedical Press, Amsterdam, pp 3–13
 22. MARRÈ MT, FG ALBERGONI, E MARRÈ 1987 Electrogenic H⁺ extrusion in *Elodea densa* leaves. VII International Workshop on Plant Membrane Transport, Sydney, August 1986. In press
 23. NEUFELD E, AW BORON 1987 A plasmamembrane redox system and proton transport in isolated mesophyll cells. *Plant Physiol* 83: 895–899
 24. RASI-CALDOGNO F, MC PUGLIARELLO 1985 Fusicoccin stimulates H⁺ ATPase of plasmalemma in isolated membrane vesicles from radish. *Biochem Biophys Res Comm* 133: 280–285
 25. RASI-CALDOGNO F, MI DE MICHELIS, MC PUGLIARELLO, E MARRÈ 1986 H⁺ pumping driven by the plasma membrane ATPase in membrane vesicles from radish: stimulation by fusicoccin. *Plant Physiol* 82: 121–125
 26. ROMANI G, MT MARRÈ, M BELLANDO, G ALLOATTI, E MARRÈ 1985 H⁺ extrusion and potassium uptake associated with potential hyperpolarization in maize and wheat root segments treated with permeant weak acids. *Plant Physiol* 79: 734–739
 27. RUBINSTEIN B, AI STERN 1986 Relationship of transplasmalemma redox activity to proton and solute transport by roots of zea mays. *Plant Physiol* 80: 805–811
 28. SIMONS PC, FC LANFERMEIJER, AH DE BOER, HBA PRINS, HFB BIENFAIT 1984 Depolarization of cell membrane potential during trans-plasmamembrane electron transfer to extracellular electron acceptors in iron-deficient roots of *Phaseolus vulgaris* L. *Plant Physiol* 76: 943–946
 29. SIMONS PC, W VAN DEN BRIEL, HF BIENFAIT 1984 Cytosolic NADPH is the electron donor for extracellular Fe^{III} reduction in iron-deficient bean roots. *Plant Physiol* 75: 219–221