

Activation of G proteins by (R_p) and (S_p) diastereomers of guanosine 5'-[β -thio]triphosphate in hamster fibroblasts

Differential stereospecificity of G_i , G_s and G_p

Sonia PARIS*† and Fritz ECKSTEIN†

*CNRS-Institut de Pharmacologie, 660 route des Lucioles, Sophia Antipolis, 06560 Valbonne, France, and †Max-Planck-Institut für experimentelle Medizin, Hermann-Rein-Strasse 3, 3400 Göttingen, Germany

The effects of guanosine 5'-[β -thio]triphosphate (GTP β [S]) on G proteins have been examined in Chinese hamster lung fibroblasts (CCL39 line) permeabilized with α -toxin from *Staphylococcus aureus*. Although much less effective than guanosine 5'-[γ -thio]triphosphate (GTP γ [S]), both (R_p) and (S_p) diastereomers of GTP β [S] were found to activate three G protein-mediated pathways: inhibition of forskolin-stimulated adenylate cyclase (mediated by G_i), potentiation of receptor-mediated activation of adenylate cyclase (mediated by G_s), and activation of phosphoinositide breakdown (mediated by G_p). Activation of G_i and G_s occurred above 3 μ M-GTP β [S], but activation of G_p only occurred above 100 μ M-GTP β [S]. Moreover, the order of effectiveness of the two diastereomers was not the same for the three G protein-mediated processes. Whereas both G_i and G_s were more effectively activated (about 5-fold) by (S_p)-GTP β [S] than by (R_p)-GTP β [S], G_p showed a marked preference for the (R_p) isomer. Indeed, (R_p)-GTP β [S] induced the formation of inositol phosphates with a shorter latency and was a better competitor of GDP for binding to G_p than the (S_p) isomer. These results point to different guanine nucleotide-binding properties for G_i and G_s on the one hand and G_p on the other. At least two distinct G_p proteins, differing by their sensitivity to pertussis toxin, are present in CCL39 cells. Since pretreatment of cells with pertussis toxin completely suppressed the effects of (R_p)-GTP β [S] on G_i , while only slightly attenuating its effects on G_p , we believe that it is the pertussis toxin-insensitive G_p which prefers the (R_p) isomer. Therefore (R_p)-GTP β [S] may be a valuable tool for the selective activation and the biochemical characterization of this pertussis toxin-insensitive G_p .

INTRODUCTION

Hydrolysis-resistant analogues of guanine nucleotides, and particularly phosphorothioates [1], have proven to be useful tools for probing the involvement of G proteins in signalling pathways. Guanosine 5'-[γ -thio]triphosphate (GTP γ [S]), for instance, causes persistent activation of G proteins in the absence of hormones, whereas guanosine 5'-[β -thio]diphosphate (GDP β [S]) has been frequently used as a competitive inhibitor of GTP to prevent or terminate G protein activation [2,3]. Unexpectedly, however, GDP β [S] was found to activate G proteins in Chinese hamster lung fibroblasts (CCL39 line), mimicking all the effects of GTP γ [S] after a lag phase of 15–20 min [4]. It was therefore postulated that GDP β [S] was phosphorylated to GTP β [S] in CCL39 cells, and that GTP β [S] could activate G proteins in the same way as GTP γ [S] [4].

The second part of this hypothesis has been directly tested here by examining the effects of (R_p) and (S_p) diastereomers of GTP β [S] on three G protein-mediated regulations in CCL39 cells: inhibition and activation of adenylate cyclase (G_i - and G_s -mediated pathways respectively), and stimulation of polyphosphoinositide breakdown by phospholipase C (PLC) (G_p -mediated activation). It should be stressed that the terms G_i , G_s and G_p are used here to refer to the functions of the G proteins, rather than to the entities, since there is increasing evidence that several G proteins can mediate the same function, and conversely

that distinct functions can be mediated by a single G protein. For instance, at least three different G proteins (G_{i1} , G_{i2} and G_{i3}) can mediate inhibition of adenylate cyclase [5], two of which, G_{i2} and G_{i3} , are present in CCL39 cells [6]. On the other hand, PLC activation in CCL39 cells is believed to involve at least two G proteins, a pertussis toxin-sensitive G protein, which may be one of the G_i proteins, and a pertussis toxin-insensitive one. This conclusion is based on the observations that treatment of cells with pertussis toxin markedly reduces the activation of PLC by thrombin [7], AlF_4^- [8] and GTP γ [S] [4], whereas carbachol-induced activation of PLC in CCL39 cells expressing M_1 muscarinic acetylcholine receptors is completely insensitive to the toxin [9].

In order to permit free passage of GTP analogues through the plasma membrane, and also to deplete the endogeneous pool of guanine nucleotides, CCL39 cells have been permeabilized by treatment with α -toxin from *Staphylococcus aureus*. This toxin assembles into a ring-structured hexamer at the membrane surface, generating a transmembrane pore with a diameter of 2–3 nm [10], a size which allows passage of small molecules but not of proteins [11,12].

This report shows that both (R_p)- and (S_p)-GTP β [S] can indeed activate G_i , G_s and G_p in permeabilized CCL39 cells, but with different relative efficiencies. Most interestingly, G_p differs from G_i and G_s by its marked preference for the (R_p)-diastereomer, which is consistent with the observation that (R_p)-

Abbreviations used: DMEM, Dulbecco's modified Eagle's medium; GTP β [S], guanosine 5'-[β -thio]triphosphate; GTP γ [S], guanosine 5'-[γ -thio]triphosphate; GDP β [S], guanosine 5'-[β -thio]diphosphate; Gpp[NH]p, guanosine 5'-[β -imido]triphosphate; G_i , inhibitory G protein of adenylate cyclase; G_s , stimulatory G protein of adenylate cyclase; G_p , stimulatory G protein of phospholipase C; IBMX, 3-isobutyl-1-methylxanthine; PLC, phosphoinositide-specific phospholipase C; PGE $_1$, prostaglandin E $_1$.

† To whom correspondence should be addressed.

GTP β [S] selectively activates Ca²⁺ signalling in mast cells [13]. This result suggests that the various G proteins differ in their nucleotide-binding site.

EXPERIMENTAL

Materials

GTP γ [S] and guanosine 5'-[$\beta\gamma$ -imido]triphosphate (Gpp-[NH]p) were purchased from Boehringer Mannheim. *S. aureus* α -toxin was from Diagnostics Pasteur (Marnes-la-Coquette, France). Pertussis toxin, forskolin, 3-isobutyl-1-methylxanthine (IBMX) and prostaglandin E₁ (PGE₁) were supplied by Sigma. [³H]Adenine, [2,8-³H]ATP and *myo*-[2-³H]inositol were from Amersham Corp.

Synthesis of GTP β [S]

The (*R*_p) and (*S*_p) diastereomers of GTP β [S] (Fig. 1) were synthesized as described [14].

Cell culture

The Chinese hamster lung fibroblast line CCL39 (American Type Culture Collection) was maintained in Dulbecco's modified Eagle's medium (DMEM; Gibco) supplemented with 5% (v/v) fetal calf serum, antibiotics (50 units of penicillin/ml and 50 μ g of streptomycin/ml) and 25 mM-bicarbonate at 37 °C in CO₂/air (1:19). Confluent cultures in 35 mm dishes (~0.3 mg of protein) were rendered quiescent by a 24 h incubation in serum-free DMEM.

When cells were pretreated with pertussis toxin, the toxin (100 ng/ml) was added 5–6 h before the start of the experiment.

Cell permeabilization

S. aureus α -toxin was purified by ammonium sulphate precipitation at 80% saturation and stored as a suspension in an 80%-satd. ammonium sulphate solution at 4 °C [15]. The haemolytic activity of α -toxin was measured by monitoring the lysis of rabbit erythrocytes [16], and the amount of toxin required to permeabilize CCL39 cells was determined empirically for each batch of toxin by measuring the release of [³H]adenine nucleotides (see the Results section). Optimal permeabilization was usually achieved by incubation at 37 °C for 45–60 min with 75–125 haemolytic units of α -toxin/ml in a HEPES-buffered saline solution containing 110 mM-KCl, 20 mM-NaCl, 5 mM-MgCl₂, 0.4 mM-CaCl₂, 0.5 mM-EGTA (0.5 μ M free Ca²⁺) and 20 mM-HEPES/Tris, pH 7.3 (buffer A).

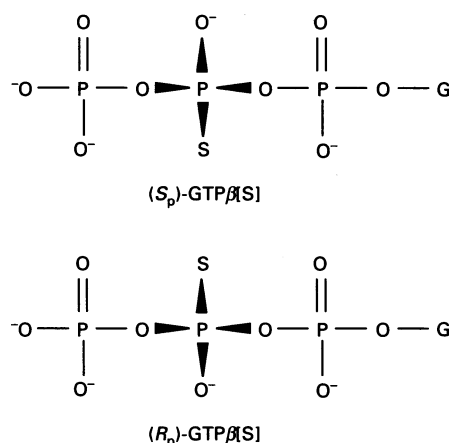

Fig. 1. Absolute configurations of the diastereomers of GTP β [S]

Measurement of cyclic AMP production

Quiescent cells were permeabilized as described above and then incubated at 37 °C in 0.7 ml of buffer A supplemented with 1 mM-IBMX and 0.2 mM-[³H]ATP (3 μ Ci/ml). GTP analogues, forskolin and PGE₁ were added as indicated in the Figure legends. The reaction was stopped by addition of 0.3 ml of ice-cold 15% (w/v) trichloroacetic acid containing 5 mM-cyclic AMP and 5 mM-ATP, and immediate cooling on ice. After 15 min the acid extract was removed and the dish was rinsed with 0.5 ml of water. The pooled extract and wash was then subjected to Dowex/alumina double-column chromatography, to separate [³H]cyclic AMP [17].

Measurement of phosphoinositide breakdown

Quiescent cells prelabelled with [³H]inositol (1 μ Ci/ml, 24 h) were washed with buffer A and permeabilized with α -toxin as described above. The medium was then removed and replaced with 0.7 ml of buffer A supplemented with 20 mM-LiCl and 2 mM-ATP, and the formation of [³H]inositol phosphates was initiated by addition of GTP analogues, as indicated. The reaction was stopped at desired times by addition of 0.1 ml of 35% (w/v) HClO₄ and immediate cooling on ice. After 15 min the acid extract was removed and the dish rinsed with 0.4 ml of water. The combined extract and wash was neutralized with KOH and separated by anion-exchange chromatography as described [4].

RESULTS

Permeabilization of CCL39 cells

The permeabilization of CCL39 cells to nucleotides was monitored by measuring the release of radioactive adenine nucleotides. Cells were preincubated with [³H]adenine in order to label the adenine nucleotide pool. Subsequently, following a wash to remove extracellular [³H]adenine, the cells were incubated with increasing α -toxin concentrations and the acid-soluble radioactivity remaining in cells was determined after various incubation times. As shown in Fig. 2, the rate of nucleotide

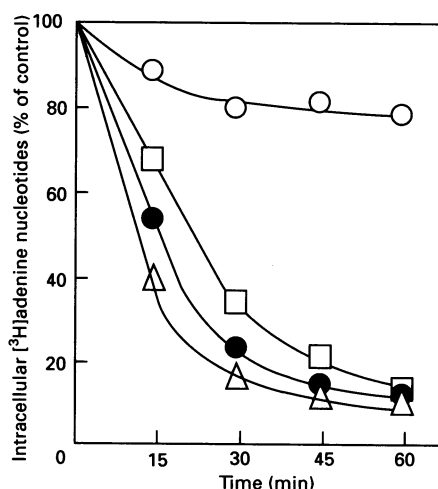

Fig. 2. Assay of permeabilization of CCL39 cells to nucleotides by α -toxin

Quiescent CCL39 cells prelabelled with [³H]adenine (0.5 μ Ci/ml, 24 h) were washed with buffer A and incubated in this medium with various concentrations of α -toxin (units/ml): \circ , 0; \square , 50; \bullet , 75; \triangle , 100. At the indicated times, the cultures were rapidly washed three times with ice-cold buffer A and extracted with 5% trichloroacetic acid. Radioactivity present in the acid extract was measured and expressed as a percentage of the control value at time 0 (~200 000 d.p.m./dish).

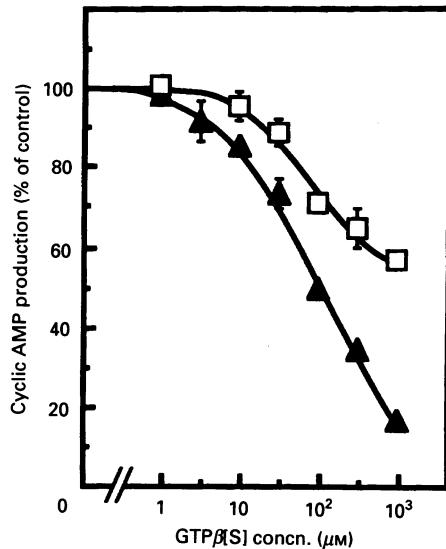

Fig. 3. Inhibitory effects of (R_p)- and (S_p)-GTP β [S] on forskolin-stimulated cyclic AMP production

Cells were permeabilized for 60 min with 125 units of α -toxin/ml before being incubated with IBMX and [3 H]ATP as described in the Experimental section. (R_p)-GTP β [S] (\square) or (S_p)-GTP β [S] (\blacktriangle) was added at the indicated concentration immediately after IBMX, and forskolin (100 μ M) was added 10 min later. The reaction was stopped 20 min after forskolin addition, and [3 H]cyclic AMP was determined. The basal [3 H]cyclic AMP level, measured in the sole presence of IBMX, was subtracted (180 d.p.m./dish). The control value (100%) was 2500 d.p.m./20 min. Values are means of duplicate determinations.

Table 1. Effect of (S_p)-GTP β [S] on forskolin-stimulated cyclic AMP production in the presence of increasing concentrations of (R_p)-GTP β [S]

Conditions were as described for Fig. 3. Cells were incubated for 10 min with the indicated concentrations of (R_p)- and (S_p)-GTP β [S] and were then stimulated for 20 min with 100 μ M-forskolin. The control value for cyclic AMP production (100%) was 3400 ± 200 d.p.m./20 min. Values are means of duplicates that differed by less than 10%.

GTP β [S] concentration (mM)		Cyclic AMP production (% of control)
(R_p)	(S_p)	
0	0	100
0.3	0	62
0	0.3	35
0.1	0.3	30
0.3	0.3	28
1	0.3	28

release increased with the toxin concentration, and maximal release was achieved after 45–60 min for toxin concentrations above 50 units/ml. For all subsequent experiments reported here, the cells were permeabilized by incubation with 100 or 125 units of toxin/ml for 45 or 60 min. Under these conditions of maximal release, the endogenous nucleotide pool was assumed to be depleted by at least 90%. The permeabilization was performed in a cytosolic-type saline solution, and free Ca^{2+} was buffered to 0.5 μ M, a concentration which allows maximal stimulation of inositol phosphate formation by GTP γ [S] without causing any significant increase in the basal activity (see below).

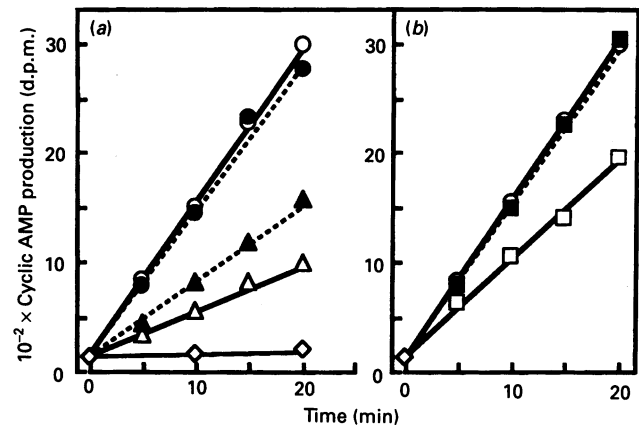

Fig. 4. Effect of pertussis toxin on (S_p)- and (R_p)-GTP β [S]-induced inhibition of forskolin-stimulated cyclic AMP production

Conditions were as described for Fig. 3. Cells pretreated (filled symbols) or not (open symbols) with pertussis toxin (100 ng/ml) for 6 h were permeabilized and then incubated with [3 H]ATP and IBMX. Some cultures received 0.3 mM-(S_p)-GTP β [S] (Δ , \blacktriangle) or 0.3 mM-(R_p)-GTP β [S] (\square , \blacksquare). After 10 min, 100 μ M-forskolin was added to all cultures except to control dishes incubated with IBMX alone (\diamond). [3 H]Cyclic AMP production was determined at the indicated times after forskolin addition.

Activation of G_i by (R_p)- and (S_p)-GTP β [S]

Adenylate cyclase activity in permeabilized CCL39 cells was measured by the conversion of [3 H]ATP into [3 H]cyclic AMP in the presence of the phosphodiesterase inhibitor IBMX. The basal activity was hardly detectable, but cyclic AMP production was markedly stimulated by 100 μ M-forskolin, as shown in Fig. 4. Both (R_p)- and (S_p)-GTP β [S] caused a concentration-dependent inhibition of forskolin-stimulated cyclic AMP production (Fig. 3). The (S_p) isomer was however notably more effective, since 50% inhibition was obtained with 100 μ M-(S_p)-GTP β [S], whereas even 1 mM of the (R_p) isomer only caused 40% inhibition. Before concluding, however, that G_i activity was preferentially induced by the (S_p) isomer, it was necessary to rule out the possibility that (R_p)-GTP β [S]-mediated activation of G_i could be masked by an opposing activation of G_s or an activation of protein kinase C, previously shown to suppress G_i -mediated inhibition of adenylate cyclase in CCL39 cells [18]. We therefore examined whether (R_p)-GTP β [S] could attenuate (S_p)-GTP β [S]-mediated inhibition of the cyclase. This however was not the case (Table 1). The inhibitory effects of 0.3 mM-(S_p)-GTP β [S] were maintained and even slightly reinforced upon addition of increasing concentrations of the (R_p) isomer. This demonstrates that G_i is indeed differentially activated by the two diastereomers of GTP β [S], with a marked preference for the (S_p) configuration. It was not possible to compare the GTP β [S] isomers with GTP γ [S] or Gpp[NH]p for their effectiveness in G_i activation, since neither GTP γ [S] nor Gpp[NH]p was found to cause any significant inhibition of forskolin-stimulated cyclic AMP production in permeabilized CCL39 cells, even at submicromolar concentrations. The most likely explanation is that the strong activation of G_s induced by these analogues (see below) completely obliterated the effect on G_i .

Pretreatment of cells with pertussis toxin resulted in a complete suppression of (R_p)-GTP β [S]-induced inhibition of forskolin-stimulated cyclic AMP production (Fig. 4b), whereas it only attenuated the (S_p)-GTP β [S]-dependent inhibition (Fig. 4a). It should be noted, however, that the magnitude of the pertussis toxin effects was dependent on the concentration of (S_p)-GTP β [S].

Whereas the inhibition of cyclic AMP production was attenuated by only 25% after the toxin pretreatment at 0.3 mM- (S_p) -GTP β [S] (Fig. 4), it was decreased by 50% at 0.1 mM- (S_p) -GTP β [S] (results not shown). This suggests that ADP-ribosylation of G_i causes a shift of the dose-response to higher concentrations of (S_p) -GTP β [S], as has been observed for Gpp[NH]p and GTP in G_s -deficient membranes [19].

Activation of G_s by (R_p) - and (S_p) -GTP β [S]

In the absence of an adenylate cyclase stimulatory hormone, both (R_p) - and (S_p) -GTP β [S] failed to increase cyclic AMP production, even at concentrations as high as 1 mM (Fig. 5a). In contrast, the cyclase activity was markedly stimulated by GTP γ [S] and Gpp[NH]p, with half-maximal effects around 0.3 μ M and 3 μ M respectively. These data suggest either that the GTP β [S] isomers cannot activate G_s by spontaneous nucleotide exchange due to a very low affinity for G_s or, alternatively, that G_s activation does occur but is not sufficient to overcome the activation of G_i (see above). Therefore the effects of GTP β [S] isomers on cyclic AMP production were next examined in cells pretreated with pertussis toxin, in order to suppress or at least attenuate the activation of G_i , and in the presence of the cyclase stimulatory factor PGE $_1$, in order to facilitate nucleotide exchange. As shown in Fig. 5(b), the activation of G_s by GTP β [S] isomers could be revealed under these conditions. PGE $_1$ alone caused a small increase in cyclic AMP production, presumably due to the residual endogenous GTP, but this stimulation was markedly potentiated by addition of (R_p) - or (S_p) -GTP β [S]. Activation of G_s by (R_p) -GTP β [S] was detectable above 10 μ M and steadily increased up to 1 mM, almost reaching the maximal effect induced by Gpp[NH]p. In contrast, the (S_p) isomer activated G_s at lower concentrations, but the concentration-dependence curve exhibited a bell shape, with a maximum around 100 μ M. A likely explanation is that the activation of G_i was not completely suppressed by pertussis toxin at high (S_p) -GTP β [S] concentrations, which resulted in a progressive attenuation of G_s activity. Comparison of the concentration-dependence curves for Gpp[NH]p, (S_p) -GTP β [S] and (R_p) -GTP β [S]

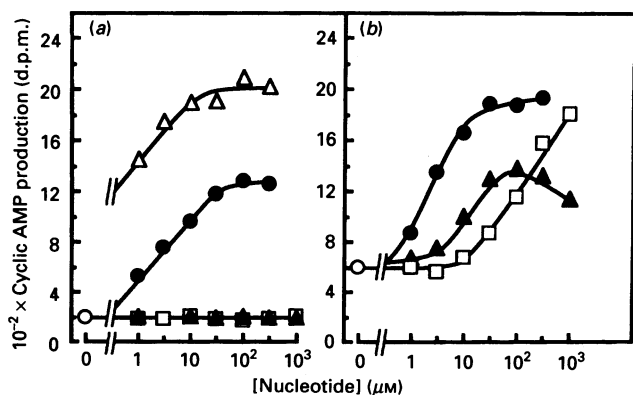

Fig. 5. Comparison of effects of (R_p) -GTP β [S], (S_p) -GTP β [S], Gpp[NH]p and GTP γ [S] on G_s .

(a) Cells were permeabilized for 60 min with 125 units of α -toxin/ml and were then incubated with [3 H]ATP and IBMX. After 5 min the reaction was started by addition of the indicated concentrations of GTP γ [S] (Δ), Gpp[NH]p (\bullet), (R_p) -GTP β [S] (\square) or (S_p) -GTP β [S] (\blacktriangle), and was stopped 30 min later. (b) Cells were pretreated with 100 ng of pertussis toxin/ml for 6 h before being permeabilized as above. The nucleotides were added immediately after IBMX, and 10 μ M-PGE $_1$ was added after a further 5 min. The reaction was stopped 20 min later.

[S] shows that 3 μ M-Gpp[NH]p (concentration giving half-maximal stimulation for this nucleotide) was equivalent to 30 μ M- (S_p) -GTP β [S] and to 150 μ M- (R_p) -GTP β [S] for the potentiation of PGE $_1$ -stimulated cyclic AMP production.

Activation of G_p by (R_p) - and (S_p) -GTP β [S]

Hydrolysis of phosphoinositides by PLC was assayed in permeabilized CCL39 cells prelabelled with [3 H]inositol by measuring the accumulation of radioactive inositol phosphates in the presence of Li $^+$. The basal PLC activity was increased by Ca $^{2+}$, but only at high concentrations, with half-maximal activation occurring at around 50 μ M-Ca $^{2+}$. In contrast, GTP γ [S]-stimulated inositol phosphate formation was markedly less dependent on Ca $^{2+}$. A substantial activation of PLC by GTP γ [S] was observed in Ca $^{2+}$ -free medium (in the presence of 0.5 mM-EGTA), and this activation was only doubled by increasing the free Ca $^{2+}$ concentration from 10 $^{-9}$ to 10 $^{-6}$ M, with a half-maximal effect occurring at approx. 30 nM-Ca $^{2+}$. In all experiments reported here, the effects of GTP analogues on PLC were therefore examined at 0.5 μ M free Ca $^{2+}$. Moreover, 2 mM-ATP was routinely included in the incubation medium to optimize inositol phosphate production, since it was observed that inositol phosphate accumulation rapidly levelled off in the absence of added ATP, presumably due to a limiting polyphosphoinositide regeneration. It should be noted that CCL39 cells apparently do not possess purinergic receptors, because ATP (even in the millimolar range) fails to activate PLC in intact cells (results not shown).

Fig. 6 shows the time course of inositol phosphate production in permeabilized CCL39 cells stimulated with 1 mM-GTP γ [S], (R_p) -GTP β [S] or (S_p) -GTP β [S]. Although notably less effective than GTP γ [S], both isomers of GTP β [S] could activate PLC, after a significant lag phase. Onset of steady-state activation occurred after a lag of approx. 5 min for (R_p) -GTP β [S] and 10 min for (S_p) -GTP β [S] (see also Fig. 8). No lag was observed with 1 mM-GTP γ [S]. At lower GTP γ [S] concentrations (10 μ M and below), a small lag was occasionally observed which never exceeded 2 min. Thus the latency observed with GTP β [S] isomers cannot be ascribed to a rate-limiting diffusion of nucleotides into cells, but is more likely to be due to the slow exchange of (S_p) -

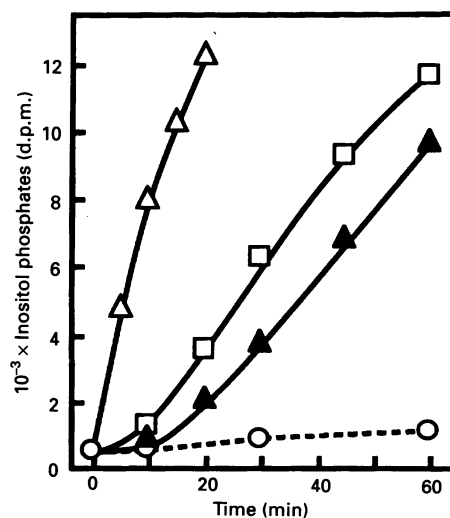

Fig. 6. Stimulation of inositol phosphate formation by GTP γ [S], (R_p) -GTP β [S] and (S_p) -GTP β [S] in permeabilized CCL39 cells

[3 H]inositol-labelled cells were permeabilized with 100 units of α -toxin/ml for 45 min and were then incubated in buffer A with 2 mM-ATP, 20 mM-LiCl and 1 mM-GTP γ [S] (Δ), 1 mM- (R_p) -GTP β [S] (\square), 1 mM- (S_p) -GTP β [S] (\blacktriangle) or no addition (\circ). Total inositol phosphates were determined at the indicated times.

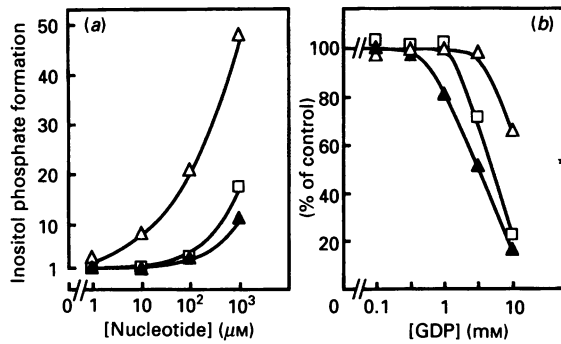

Fig. 7. Concentration-dependence of effects of GTP γ [S], (*R_p*)-GTP β [S] and (*S_p*)-GTP β [S] on inositol phosphate formation, and inhibition by GDP

Conditions were as described for Fig. 6. (a) GTP γ [S] (Δ), (*R_p*)-GTP β [S] (\square), (*S_p*)-GTP β [S] (\blacktriangle) was added at the indicated concentrations and the reaction was stopped after 20 min for GTP γ [S] or 45 min for (*R_p*)- and (*S_p*)-GTP β [S]. Data were normalized relative to the basal accumulation of inositol phosphates (= 1) measured with LiCl alone (210 d.p.m./20 min and 470 d.p.m./45 min). (b) GTP γ [S] (Δ), (*R_p*)-GTP β [S] (\square) or (*S_p*)-GTP β [S] (\blacktriangle) was added at 1 mM in the presence of increasing concentrations of GDP. The reaction was stopped after 10 min for GTP γ [S] and 40 min for (*R_p*)- and (*S_p*)-GTP β [S]. The 100% value (measured in the absence of GDP) corresponds to 6200 d.p.m./10 min for GTP γ [S], 6500 d.p.m./40 min for (*R_p*)-GTP β [S] and 5200 d.p.m./40 min for (*S_p*)-GTP β [S].

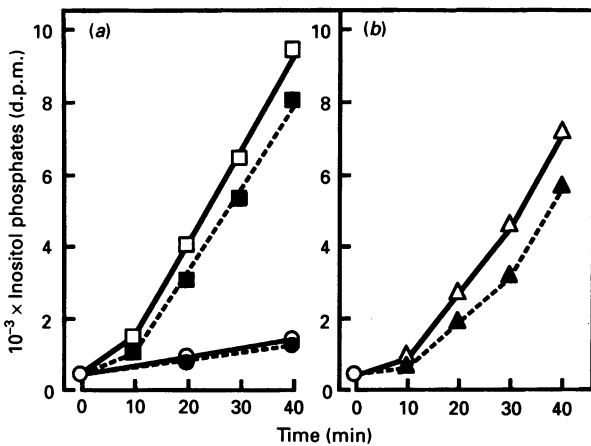

Fig. 8. Effect of pertussis toxin on (*R_p*)- and (*S_p*)-GTP β [S]-induced inositol phosphate formation

Cells were pretreated (filled symbols) or not (open symbols) with 100 ng of pertussis toxin/ml for 5 h and permeabilized as described for Fig. 6. Inositol phosphate formation was then stimulated with 1 mM-(*R_p*)-GTP β [S] (\square , \blacksquare) or 1 mM-(*S_p*)-GTP β [S] (Δ , \blacktriangle) in the presence of 20 mM-LiCl. Control dishes were incubated with LiCl alone (\circ , \bullet).

GTP β [S] and, to a lesser extent, (*R_p*)-GTP β [S] for bound GDP on the G protein(s) coupled to PLC.

Interestingly, (*R_p*)-GTP β [S] was more effective than (*S_p*)-GTP β [S] for *G_p* activation, in marked contrast with the activations of *G_i* and *G_s*. This is further illustrated by the concentration-dependence presented in Fig. 7(a). Note that PLC activation was hardly detectable below a concentration of 100 μM of both GTP β [S] isomers, whereas 1 μM -GTP γ [S] already promoted a measurable inositol phosphate production. With GTP, PLC activation could be detected only above 3 mM (results not shown). Surprisingly, PLC activity was not saturated with 1 mM-GTP γ [S], despite a 50-fold stimulation over the basal activity,

which may be relevant to the absence of saturation observed for thrombin-stimulated PLC in intact CCL39 cells [7,20]. In accordance with the order of effectiveness of the three GTP analogues, GDP was found to compete more easily with (*S_p*)-GTP β [S] than with the (*R_p*) isomer, while a large excess of GDP was necessary to displace GTP γ [S]. As shown in Fig. 7(b), the stimulation obtained by addition of 1 mM of each GTP analogue was 50% inhibited by 3 mM-GDP for (*S_p*)-GTP β [S], 5 mM-GDP for (*R_p*)-GTP β [S] and ~15 mM-GDP (obtained by extrapolation) for GTP γ [S].

Although (*S_p*)-GTP β [S] appears to activate *G_p* more slowly than (*R_p*)-GTP β [S], it should be noted that a nearly equivalent steady-state activation of PLC was nevertheless attained with both isomers after a prolonged incubation [compare the rates of inositol phosphate production after a 30 min incubation with 1 mM-(*R_p*)- or (*S_p*)-GTP β [S] in Figs. 6 and 8]. Thus the (*S_p*) configuration retards the activation of *G_p* by GTP β [S], but does not seem to affect the interaction of the activated G protein(s) with PLC.

Fig. 8 shows that pretreatment of cells with pertussis toxin resulted in only a modest inhibition of PLC activation by (*R_p*)- and (*S_p*)-GTP β [S]. The inhibition was essentially due to an increase of the lag phase, particularly with (*S_p*)-GTP β [S] but, again, a similar rate of inositol phosphate production was attained after 30 min with both isomers in control as well as in pertussis toxin-treated cells.

DISCUSSION

In this study we show that both (*R_p*) and (*S_p*) diastereomers of GTP β [S] can activate three G protein-mediated signalling pathways in α -toxin-permeabilized Chinese hamster CCL39 fibroblasts, namely the *G_i*, *G_s* and *G_p* activities leading to inhibition or activation of adenylate cyclase and to activation of phosphoinositide breakdown respectively. These results therefore nicely support our previous hypothesis [4] that the activation of G proteins induced by GDP β [S] in these cells is due to the phosphorylation of GDP β [S] to GTP β [S]. Evidence that a nucleoside diphosphate kinase plays indeed a role in G protein activation in CCL39 cells has been obtained (S. Paris, unpublished work).

It should be pointed out, however, that both GTP β [S] isomers are very poor activators of G proteins compared with GTP γ [S]. This is consistent with the conclusions of earlier studies on transducin [21], ras protein [22] and prokaryotic elongation factor Tu [23] that both the pro-*R* and the pro-*S* oxygen atoms at the β -phosphorus of GTP are involved in key interactions with the protein or Mg^{2+} , and that substitution of one of these oxygen atoms with sulphur greatly reduces the binding affinity of the guanine nucleotide to the G protein. This low effectiveness of GTP β [S] isomers certainly explains the apparent lack of effect of these phosphorothioate analogues on *G_s* in the absence of an adenylate cyclase stimulatory factor, observed in this study (Fig. 5a) as well as in another cell system [24]. In our hands, activation of *G_s* by GTP β [S] was best revealed in the presence of PGE₁ and after treatment of cells with pertussis toxin to suppress or attenuate the activation of *G_i*. Conversely, GTP β [S] isomers are most suitable GTP analogues to probe the activation of *G_i* in cell or membrane systems also containing *G_s*, since the activation of *G_i* by these analogues is not concealed by that of *G_s*, as is often the case with GTP γ [S] or even Gpp[NH]p.

Most interestingly, the order of effectiveness of the two diastereomers of GTP β [S] was not the same for the three G protein-mediated pathways studied here. Whereas both *G_i* and *G_s* were more readily activated by (*S_p*)-GTP β [S] than by the (*R_p*) isomer, thereby resembling transducin [21], *G_p* in contrast

exhibited a marked preference for the (R_p) diastereomer. It should be stressed that the apparent potency of a given analogue in stimulating a G protein-mediated event is not a direct measure of its binding affinity for the G protein, but rather an overall reflection of its affinity and its resistance to hydrolysis. Both isomers of GTP β [S] were shown to be cleaved by ras protein at a measurable rate, although considerably slower than for GTP, and with a marked preference for the (R_p) isomer [22]. Moreover, it is difficult to accurately compare the potency of the two diastereomers for activation of the various G proteins, since the maximal effect is generally not well defined (see Figs. 3, 5 and 7). If one compares the concentrations of each isomer which produce the same absolute effect, it appears that (S_p)-GTP β [S] is approx. 5-fold more active than the (R_p) isomer on G_i and G_s (Figs. 3 and 5). For G_i , however, since (R_p)-GTP β [S] seems to give no more than 40% inhibition of adenylate cyclase (Fig. 3), the possibility that this isomer activates only a subset of the total G_i pool cannot be ruled out. In the case of G_p activation, the relative potencies of the two diastereomers are even more difficult to estimate due to the time-dependent increase in PLC activity. In fact, (S_p)-GTP β [S] appears to activate G_p more slowly than the (R_p) isomer, but leads to a similar activation after a prolonged incubation. This suggests that the (S_p) isomer might have a lower affinity for G_p but a better resistance to hydrolysis than the (R_p) isomer. When assayed for its potency to compete with GDP on G_p , (R_p)-GTP β [S] was found to be nearly 2-fold more effective than the (S_p) isomer. Interestingly, (R_p)-GTP β [S] was similarly reported to be more effective than the (S_p) isomer for stimulating Ca^{2+} release in mast cells, and this effect was ascribed to G_p activation [13], a hypothesis which is strongly supported by our present findings. The identity of G_p proteins is still unclear. At least two distinct G proteins, one sensitive and one insensitive to pertussis toxin, are thought to mediate PLC activation in CCL39 cells [7–9], but these proteins remain to be identified. It can only be postulated that the pertussis toxin-sensitive G_p might be one of the G_i proteins, or G_o [25], while the toxin-insensitive G_p might belong to the G_q -type family [26,27]. Since PLC activation is also partially inhibited by pertussis toxin in mast cells [28], it is difficult to definitely conclude which G protein is preferentially activated by (R_p)-GTP β [S]. G_i proteins, however, appear to be very unlikely candidates, considering the higher potency of the (S_p) isomer for inducing adenylate cyclase inhibition. Moreover, our observation that pertussis toxin pretreatment causes only a modest attenuation of G_p activation by (R_p)-GTP β [S], whereas it completely suppresses the activation of G_i by this isomer, would rather favour the hypothesis that (R_p)-GTP β [S] is primarily activating the pertussis toxin-insensitive G_p . In this regard, it is interesting to note that G_q and related proteins have been found to differ from G_i and G_s proteins by a slow guanine nucleotide exchange [29,30], possibly due to subtle differences in the nucleotide-binding domain [31]. It is tempting to speculate that these differences might also change the stereospecificity of the interactions with the β -phosphate of GTP. To test this hypothesis, it would be of interest to directly assay the activation of G_q by GTP β [S] isomers in a reconstituted system.

In any case, the results of this study strengthen the conclusions of von zur Mühlen *et al.* [13] that (R_p)-GTP β [S] should be a valuable tool in further studies on G_p . Indeed, this GTP analogue can be used to selectively activate the G_p pathway, without affecting the other major G protein-mediated processes. In

addition to its lack of effect on G_o , the G protein mediating exocytosis [13], we have shown here that its effects on G_s are undetectable in the absence of an adenylate cyclase stimulatory factor, and its effects on G_i can be abolished by pertussis toxin. Such a selective activation of the G_p pathway can certainly not be obtained with more potent GTP analogues such as GTP γ [S].

We thank Marc Chabre for critical reading of the manuscript, Franck Aguila for preparing the illustrations and Gabrielle Imbs for skilful secretarial assistance.

REFERENCES

- Eckstein, F. (1985) *Annu. Rev. Biochem.* **54**, 367–402
- Eckstein, F., Cassel, D., Levkovitz, H., Lowe, M. & Selinger, Z. (1979) *J. Biol. Chem.* **254**, 9829–9834
- Cassel, D., Eckstein, F., Lowe, M. & Selinger, Z. (1979) *J. Biol. Chem.* **254**, 9835–9838
- Paris, S. & Pouyssegur, J. (1990) *J. Biol. Chem.* **265**, 11567–11575
- Kobayashi, I., Shibasaki, H., Takahashi, K., Tohyama, K., Kurachi, Y., Ito, H., Ui, M. & Katada, T. (1990) *Eur. J. Biochem.* **191**, 499–506
- Pouyssegur, J. (1990) in *G Proteins* (Iyengar, R. & Birnbaumer, L., eds.), pp. 555–570, Academic Press, New York
- Paris, S. & Pouyssegur, J. (1986) *EMBO J.* **5**, 55–60
- Paris, S. & Pouyssegur, J. (1987) *J. Biol. Chem.* **262**, 1970–1976
- Seuwen, K., Kahan, C., Hartmann, T. & Pouyssegur, J. (1990) *J. Biol. Chem.* **265**, 22292–22299
- Füssle, R., Bhakdi, S., Sziegoleit, A., Trantum-Jensen, J., Kranz, T. & Wellensiek, H. J. (1981) *J. Cell Biol.* **91**, 83–94
- Bader, M.-F., Thiersé, D., Aunis, D., Ahnert-Hilger, G. & Gratzl, M. (1986) *J. Biol. Chem.* **261**, 5777–5783
- Hohman, R. J. (1988) *Proc. Natl. Acad. Sci. U.S.A.* **85**, 1624–1628
- von zur Mühlen, F., Eckstein, F. & Penner, R. (1991) *Proc. Natl. Acad. Sci. U.S.A.* **88**, 926–930
- Connolly, B. A., Romaniuk, P. J. & Eckstein, F. (1982) *Biochemistry* **21**, 1983–1989
- Bader, M.-F., Sontag, J.-M., Thiersé, D. & Aunis, D. (1989) *J. Biol. Chem.* **264**, 16426–16434
- Bernheimer, A. W. (1988) *Methods Enzymol.* **165**, 213–217
- Johnson, R. A. & Salomon, Y. (1991) *Methods Enzymol.* **195**, 3–21
- Magnaldo, I., Pouyssegur, J. & Paris, S. (1988) *Biochem. J.* **253**, 711–719
- Sunyer, T., Monastirsky, B., Codina, J. & Birnbaumer, L. (1989) *Mol. Endocrinol.* **3**, 1115–1124
- L'Allemain, G., Paris, S., Magnaldo, I. & Pouyssegur, J. (1986) *J. Cell. Physiol.* **129**, 167–174
- Yamanaka, G., Eckstein, F. & Stryer, L. (1985) *Biochemistry* **24**, 8094–8101
- Tucker, J., Sczakiel, G., Feuerstein, J., John, J., Goody, R. S. & Wittinghofer, A. (1986) *EMBO J.* **5**, 1351–1358
- Leupold, C. M., Goody, R. S. & Wittinghofer, A. (1983) *Eur. J. Biochem.* **135**, 237–241
- Jones, D. T., Masters, S. B., Bourne, H. R. & Reed, R. R. (1990) *J. Biol. Chem.* **265**, 2671–2676
- Moriarty, T. M., Padrell, E., Carty, D. J., Omri, G., Landau, E. M. & Iyengar, R. (1990) *Nature (London)* **343**, 79–82
- Smrcka, A. V., Hepler, J. R., Brown, K. O. & Sternweis, P. C. (1991) *Science* **251**, 804–807
- Taylor, S. J., Chae, H. Z., Rhee, S. G. & Exton, J. H. (1991) *Nature (London)* **350**, 516–518
- Nakamura, T. & Ui, M. (1985) *J. Biol. Chem.* **260**, 3584–3593
- Taylor, S. J., Smith, J. A. & Exton, J. H. (1990) *J. Biol. Chem.* **265**, 17150–17156
- Pang, I.-H. & Sternweis, P. C. (1990) *J. Biol. Chem.* **265**, 18707–18712
- Strathmann, M. & Simon, M. I. (1990) *Proc. Natl. Acad. Sci. U.S.A.* **87**, 9113–9117