

Transmembrane organization of mitochondrial NADH dehydrogenase as revealed by radiochemical labelling and cross-linking

Salil D. PATEL,* M. W. J. CLEETER and C. Ian RAGAN†

Department of Biochemistry, University of Southampton, Southampton SO9 3TU, U.K.

The organization of bovine heart NADH dehydrogenase in the mitochondrial inner membrane was investigated by chemical cross-linking and radiolabelling with [¹²⁵I]iododiazobenzenesulphonate (IDABS). Mitochondria or submitochondrial particles were cross-linked with disulphosuccinimidyl tartrate and dimethyl suberimidate, and dimeric products containing subunits of the NADH dehydrogenase were analysed by Western blotting with subunit-specific antisera. Cross-linking of mitochondria gave rise to (49+30) kDa and (49+19) kDa dimers and an additional dimer containing the 30 kDa subunit. Cross-linking of submitochondrial particles gave rise to (75+51) kDa, (75+30) kDa and (49+13) kDa dimers and a further dimer containing the 30 kDa subunit. We conclude that the 49 kDa and 30 kDa subunits are transmembranous, the 19 kDa subunit is exposed on the cytoplasmic face of the membrane, whereas the 75, 51 and 13 kDa subunits are exposed on the matrix face of the membrane. Reaction of the isolated enzyme with IDABS results in labelling of 75, 49, 42, 33, 30, 13 and 10 kDa subunits. From experiments in which mitochondria or submitochondrial particles were first labelled and NADH dehydrogenase then isolated by immunoprecipitation, it was found that labelling of the 49 kDa subunit occurs predominantly from the cytoplasmic side of the membrane. On the other hand, labelling of the 75, 13 and 10 kDa subunits occurs predominantly from the matrix side of the membrane, whereas the 30 and 33 kDa subunits are heavily labelled from either side. These findings are consistent with those obtained from cross-linking.

INTRODUCTION

In previous work from this laboratory [1] it was concluded that the mitochondrial NADH dehydrogenase complex (Complex I) was transmembranous. Bovine heart mitochondria (with the outer membrane disrupted) or inverted submitochondrial particles were radiolabelled by lactoperoxidase-catalysed iodination or by reaction with ³⁵S-labelled diazobenzenesulphonate. Complex I was then isolated by immunoprecipitation and the distribution of radioactivity between the various polypeptide subunits was analysed after SDS/polyacrylamide-gel electrophoresis. The problems associated with this approach are well known. Since the membrane preparations used are unlikely to be perfectly sealed and uniformly sided, it is frequently difficult to decide whether a protein is on one side of the membrane only or is transmembranous. Analysis of label distribution in the primary sequence will of course distinguish these possibilities, but little sequence information is yet available for the subunits of Complex I.

In the preceding paper [2], we described the use of cross-linking agents to look at subunit-subunit associations in isolated Complex I. The subunits which were most extensively cross-linked were those constituting the iron-protein domain of the enzyme, and other work with a variety of hydrophilic reagents [3] had suggested that these subunits form a major part of those regions of the

enzyme exposed to the aqueous phases on either side of the membrane. We reasoned that non-penetrating cross-linking agents applied either to mitochondria or to submitochondrial particles should provide qualitatively different patterns of dimer formation which might be easier to interpret than radiochemical-labelling data. In the present paper we describe this novel application of cross-linking agents and show that the conclusions from this study are in very good agreement with the results of radiolabelling with the hydrophilic label [¹²⁵I]-iododiazobenzenesulphonate (IDABS).

MATERIALS AND METHODS

Preparations and chemicals

Mitochondria and submitochondrial particles were prepared from ox heart as described by Crane *et al.* [4] and Racker [5] respectively. For radiolabelling experiments, the mitochondria were further purified by separation into heavy-layer and light-layer fractions as described by Blair [6]. Only the heavy-layer fraction was used. Complex I was prepared by the method of Hatefi & Rieske [7]. The cross-linkers, disulphosuccinimidyl tartrate (DSST) and dimethyl suberimidate (DMS) were obtained from Pierce Chemicals, Chester, Cheshire, U.K.

Abbreviations used: IDABS, iododiazobenzenesulphonate; DSST, disulphosuccinimidyl tartrate; DMS, dimethyl suberimidate.

* Present address: Division of Biology, California Institute of Technology, Pasadena, CA 91125, U.S.A.

† Present address and address for correspondence and reprint requests: Merck Sharp & Dohme Research Laboratories, Neuroscience Research Centre, Terlings Park, Eastwick Road, Harlow, Essex, CM20 2QR, U.K.

Cross-linking

Cross-linking of Complex I was carried out exactly as described in the preceding paper [2], except that DSST was freshly dissolved in 0.25 M-sucrose/50 mM-triethanolamine/HCl buffer and adjusted to pH 8. Mitochondria were dialysed for 1 h against 200 vol. of sucrose/triethanolamine buffer before use, whereas submitochondrial particles were given a final wash by centrifugation in the same buffer. Cross-linking of mitochondria and submitochondrial particles was carried out with protein concentrations of 20 mg and 10 mg/ml respectively. Other conditions were as described in the preceding paper [2] or in the appropriate Figure legends.

SDS/polyacrylamide-gel electrophoresis and Western blotting

Electrophoresis, preparation of antisera and Western blotting were exactly as described in the preceding paper [2].

Labelling with [¹²⁵I]iodobenzenesulphonate

[¹²⁵I]Iodosulphanilic acid (500 μ Ci from New England Nuclear) was evaporated to dryness with a stream of dry N₂. The residue was taken up in 10 μ l of water and cooled to 0 °C. NaNO₂ (5 μ l of a 0.05 M solution in water) and HCl (5 μ l of a 0.1 M solution) were added sequentially and, after 5 min at 0 °C, the solution was neutralized by the addition of 20 μ l of 0.25 M-sucrose/50 mM-sodium phosphate, pH 8.0.

Complex I, mitochondria or submitochondrial particles were then added and incubated for 30 min at 0 °C. The Complex I had been previously dialysed against sucrose/phosphate buffer and was added at a ratio of 3 mg of protein/500 μ Ci of IDABS (final concn. 5 mg of protein/ml). Mitochondria and submitochondrial particles were labelled at a ratio of 9 mg of protein/500 μ Ci of IDABS (final concn. 6 mg of protein/ml). After incubation, further reaction was quenched by addition of 0.5 M-Tris/HCl, pH 8.0, to a final concentration of 20 mM. Complex I was sedimented in an Eppendorf bench centrifuge for 5 min and the pellets resuspended and re-sedimented three times in sucrose/phosphate buffer. Mitochondria were washed by sedimentation for 2 min and resuspension in 0.25 M-sucrose/50 mM-Tris/HCl, pH 7.8, containing 1% (w/v) bovine serum albumin. Submitochondrial particles were diluted 20-fold with the same buffer and sedimented by centrifugation at 100 000 g for 30 min followed by resuspension.

Protein assay

Protein was measured by the method of Lowry *et al.* [8], with bovine serum albumin (fraction V from Sigma) as a standard.

Immunoprecipitation of labelled polypeptides from Complex I

IDABS-labelled Complex I (200 μ g of protein) was diluted to 300 μ l with sucrose/phosphate buffer. SDS [200 μ l of a 10% (v/v) solution] was then added, and the mixture heated to 100 °C for 5 min. After cooling, Triton X-100 [400 μ l of a 10% (v/v) solution] was added and 100 μ l portions were mixed with 50 μ l of antiserum or 50 μ l of control serum and incubated at 4 °C for 2 h.

Antigen-antibody complexes were adsorbed on to 200 μ l of Pansorbin (Calbiochem) for 1.5 h at room temperature. The cells were washed three times by

sedimentation and resuspension in sucrose/phosphate buffer. Adsorbed protein was solubilized with 40 μ l of 0.5 M-Tris/HCl, pH 6.8, 40 μ l of 10% (w/v) SDS and 40 μ l of 10% (v/v) 2-mercaptoethanol at 100 °C for 2 min and analysed by SDS/polyacrylamide-gel electrophoresis and autoradiography using Kodak X-Omat S film at -70 °C.

Immunoprecipitation of labelled Complex I from mitochondria and submitochondrial particles

Immunoprecipitation from detergent-solubilized membranes with antiserum raised to intact Complex I was done as described by Smith & Ragan [1].

RESULTS

Choice of non-penetrating cross-linking reagents

Although most traditional cross-linking reagents are able to penetrate cell membranes, the simple addition of sulphonate residues to the reactive parts of the molecules is sufficient to render them impermeant. Thus, Staros [9,10] described the synthesis of di-isethionyl 3,3'-dithio-bispropionimide and demonstrated that it did not cross the red-cell membrane. This compound and the related di-isethionyl suberimide [11] are very unstable in aqueous solution, and Staros [10] later developed cross-linkers containing the more stable sulphosuccinimidyl group. In the present study we used a similar reagent, disulphosuccinimidyl tartrate (DSST), since we had already found that the non-sulphonated compound was a good cross-linker of Complex I.

Cross-linking of isolated Complex I with DSST produced very similar results to those obtained with DST [2]. As shown in Fig. 1, four products containing the 75 kDa iron-protein subunit were formed: the pair of (75+51) kDa dimers, a (75+30) kDa dimer and a product containing a small unidentified subunit. These assignments were confirmed with antisera to the 51 kDa and 30 kDa subunits (results not shown). Fig. 1(b) shows products containing the 49 kDa subunit. The prominent (49+30), (49+19) and (49+13) kDa dimers were clearly present, and the overall pattern was very similar to that obtained with DST at similar concentrations. The major difference was the absence of very-large- M_r products when cross-linking was performed with the higher concentrations of DSST.

Cross-linking of mitochondria and submitochondrial particles with DSST

In the experiment of Fig. 2, mitochondria and submitochondrial particles were cross-linked and analysed by Western blotting with antiserum to the 49 kDa subunit. Cross-linked products of M_r 75 000 and 68 000, previously attributed to (49+30) kDa and (49+19) kDa dimers respectively, were much more prominent in cross-linked mitochondria. On the other hand, the 63 kDa product, attributed to a (49+13) kDa dimer, was more prominent in submitochondrial particles, though less clearly so.

Analysis with antiserum to the 30 kDa subunit (Fig. 3) confirmed the identity of the 75 kDa product which again appeared as a pair of closely migrating bands. A product with an M_r of 97 000 was clearly more prominent in submitochondrial particles. In addition, some small dimers were produced in low quantity, and one of these seemed to be predominant in mitochondria. Overall, the

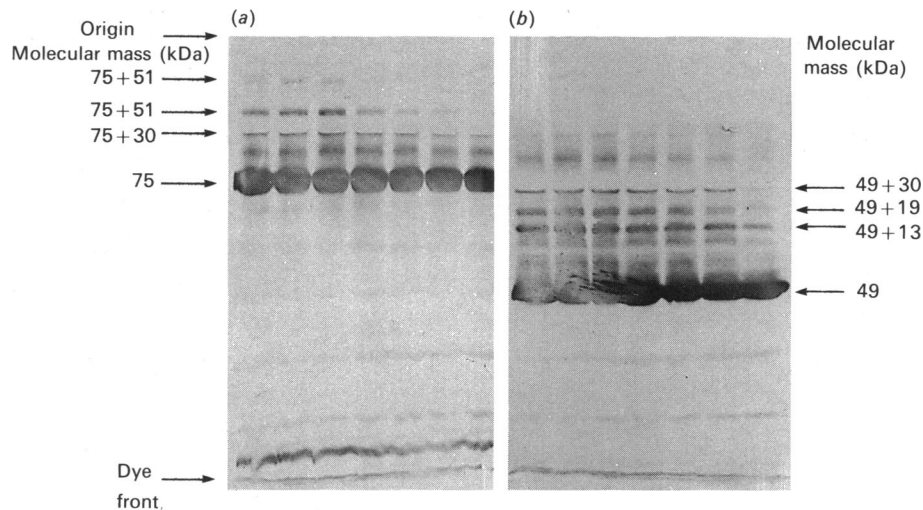

Fig. 1. Cross-linking of isolated complex I with DSST

Complex I was cross-linked with DSST. Concentrations of DSST were, from left to right: 5.0, 3.2, 2.9, 2.1, 1.4, 0.7 and 0.35 mM. Cross-linked samples were analysed by gel electrophoresis on 10% (w/v) acrylamide gels and Western blotting with antiserum to (a) the 75 kDa subunit and (b), the 49 kDa subunit.

number of clearly identified products was less than expected from cross-linking of isolated Complex I. However, this decrease in accessibility is not uncommon when comparing native with isolated membrane proteins.

The 97 kDa product was positively identified as a (75+30) kDa dimer by probing with antiserum to the 75 kDa subunit (Fig. 4). Again, this dimer was more prominent in submitochondrial particles, as was a larger

dimer identified as the (75+51) kDa product. The latter finding was entirely expected, since the 51 kDa subunit is the site of binding of NADH [12] and must therefore be exposed in part on the matrix face of the membrane.

Cross-linking of mitochondria and submitochondrial particles with DMS

Since Wang & Richards [13] had reported extensive penetration of the red-cell membrane by dimethyl 3,3'-

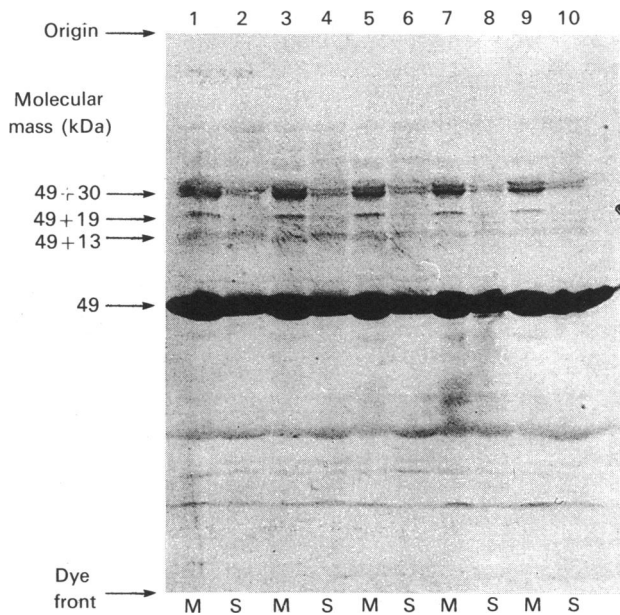

Fig. 2. Cross-linking of the 49 kDa subunit in mitochondria and submitochondrial particles with DSST

Cross-linking of mitochondria (M) and submitochondrial particles (S) was carried out with concentrations of DSST of 5 mM (tracks 1 and 2), 3.2 mM (tracks 3 and 4), 1.9 mM (tracks 5 and 6), 1 mM (tracks 7 and 8) and 0 mM (tracks 9 and 10). Samples were analysed by Western blotting with antiserum to the 49 kDa subunit.

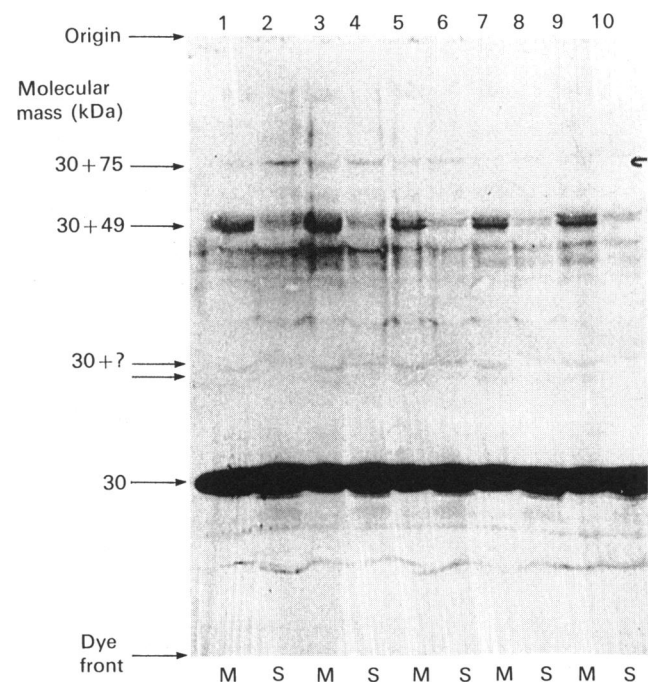

Fig. 3. Cross-linking of the 30 kDa subunit in mitochondria (M) and submitochondrial (S) particles with DSST

Conditions were exactly as in the legend to Fig. 2, except that antiserum to the 30 kDa subunit was used.

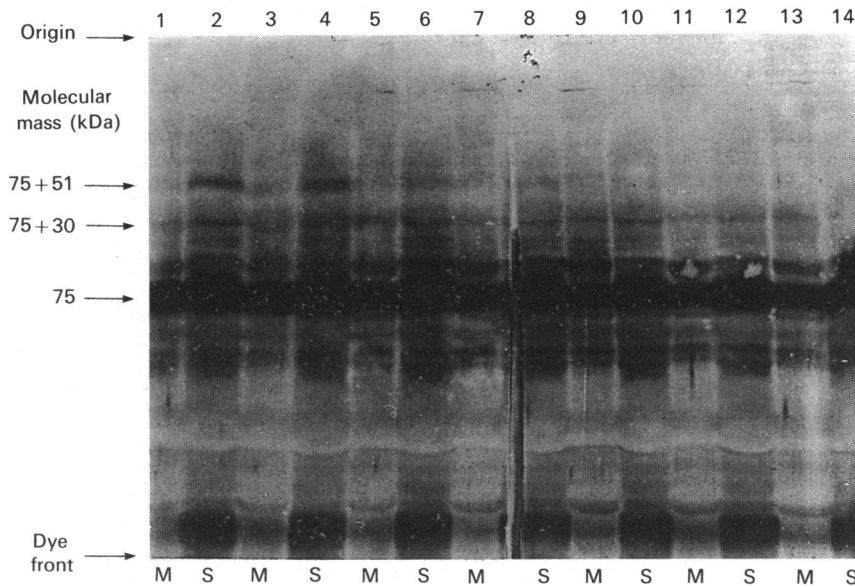

Fig. 4. Cross-linking of the 75 kDa subunit in mitochondria (M) and submitochondrial particles (S) with DSST

Conditions were exactly as in the legend to Fig. 2, except that antiserum to the 75 kDa subunit was used. Cross-linker concentrations were 5 mM (tracks 1 and 2), 3.2 mM (tracks 3 and 4), 3 mM (tracks 5 and 6), 2 mM (tracks 7 and 8), 1.2 mM (tracks 9 and 10), 0.8 mM (tracks 11 and 12) and 0 mM (tracks 13 and 14).

dithiobispropionimidate, despite the charge on the imidate moiety and its product amidine, we had expected that bisimidates in general would be unsuitable for sided cross-linking. We were surprised therefore to find that DMS proved to be a 'clean' reagent for this purpose, at least at low concentration.

As shown in Figs. 5–7, DMS had rather limited ability to cross-link membrane-bound Complex I compared with the isolated enzyme, particularly with regard to

49 kDa-subunit products [2]. Nevertheless, the (49+30) kDa dimer (Figs. 5 and 6) and the (75+30) kDa dimer (Figs. 6 and 7) could be clearly identified and were found predominantly in cross-linked mitochondria and submitochondrial particles respectively. This is particularly clear in Fig. 6, where it can also be seen that with higher DMS concentration the distinction between mitochondria and submitochondrial particles is becoming lost, consistent with penetration of the membrane by the reagent. Small dimers containing the 30 kDa subunit were also formed in submitochondrial particles and mitochondria respectively (cf. Fig. 3), but the identity of the other subunits in these was not established.

The sidedness of the various cross-linked products is summarized in Table 1.

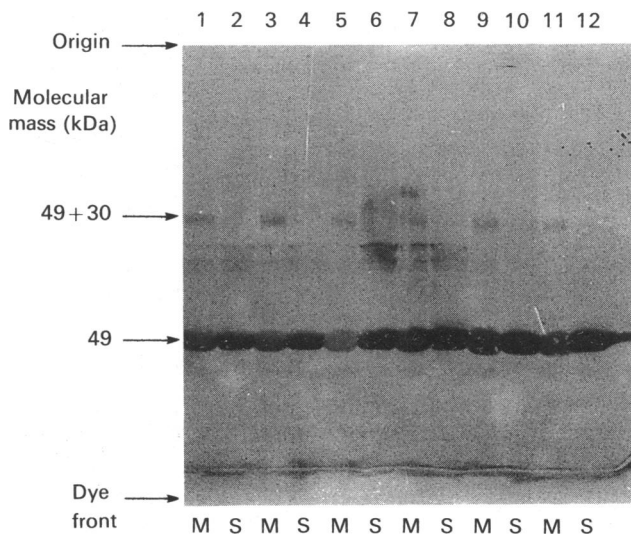

Fig. 5. Cross-linking of the 49 kDa subunit in mitochondria (M) and submitochondrial (S) particles with DMS

Conditions were exactly as in the legend to Fig. 2, except that DMS was used at concentrations of 15 mM (tracks 1 and 2), 8 mM (tracks 3 and 4), 3.7 mM (tracks 5 and 6), 1 mM (tracks 7 and 8), 0.3 mM (tracks 9 and 10) and 0 mM (tracks 11 and 12).

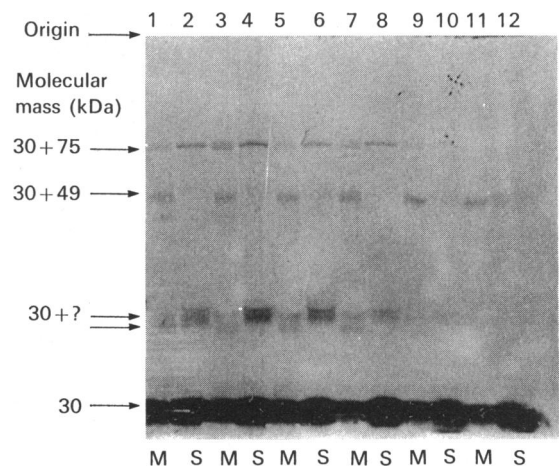

Fig. 6. Cross-linking of the 30 kDa subunit in mitochondria (M) and submitochondrial (S) particles with DMS

Conditions were otherwise as in the legend to Fig. 5. The lower part of the Western blot is not shown.

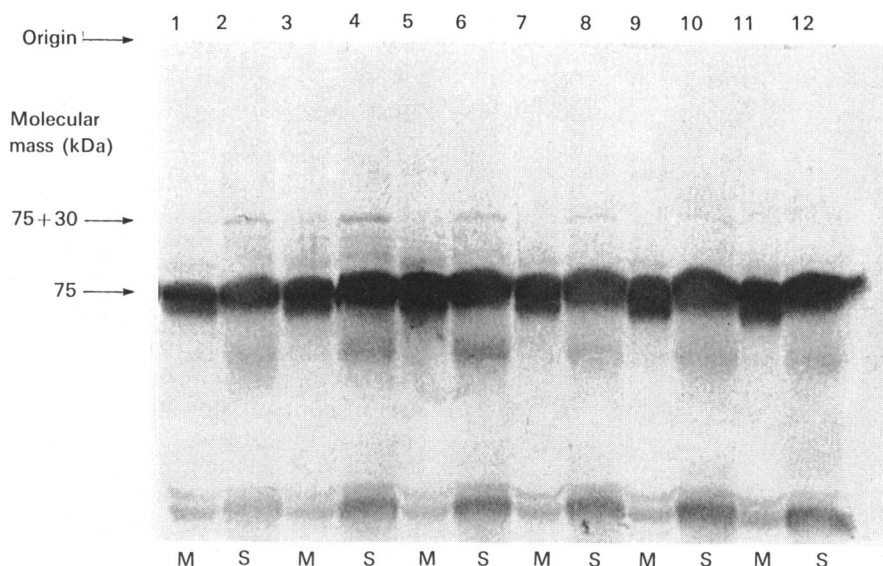

Fig. 7. Cross-linking of the 75 kDa subunit in mitochondria (M) and submitochondrial (S) particles with DMS

Conditions were otherwise as in the legend to Fig. 5. The lower part of the Western blot is not shown.

Labelling of isolated Complex I with IDABS

Fig. 8 shows the distribution of radioactivity between the subunits of Complex I after labelling with IDABS. Subunits of M_r values 75, 49, 30 and 13 kDa were labelled, and these were confirmed as iron-protein-fragment subunits by immunoprecipitation with subunit specific antisera (Fig. 8). The other labelled components were the 42, 33 (ND-1 gene product [14]) and 10 kDa subunits, which are all constituents of the hydrophobic domain. In agreement with the results of previous work with other hydrophilic probes [3], no subunits of the flavoprotein fragment were labelled.

In Complex I isolated by immunoprecipitation from IDABS-labelled mitochondria and submitochondrial particles, the distribution of label was different. As shown in Fig. 9, the labelled impurities noted in Fig. 8

were not present, and the 42 kDa subunit was absent, as reported previously [1,15]. The 75, 13 and 10 kDa subunits were heavily labelled in submitochondrial particles and only to a minor extent in mitochondria. The reverse was true of the 49 kDa subunit, whereas the 33 and 30 kDa subunits were extensively labelled in either preparation (Table 1).

Table 1. Sidedness of Complex I subunits

The upper half of the Table gives the cross-linked products formed when cross-linker is applied to either the cytoplasmic face or matrix face of the mitochondrial inner membrane. The lower half of the Table lists those subunits which are labelled by IDABS on either side of the membrane.

Method	Molecular mass (kDa)	
	Cytoplasmic face	Matrix face
Cross-linking	49 + 30	75 + 51
	49 + 19	75 + 30
	30 + small subunit	49 + 13
		30 + small subunit
IDABS labelling	49	75
	33	33
	30	30
		13
		10

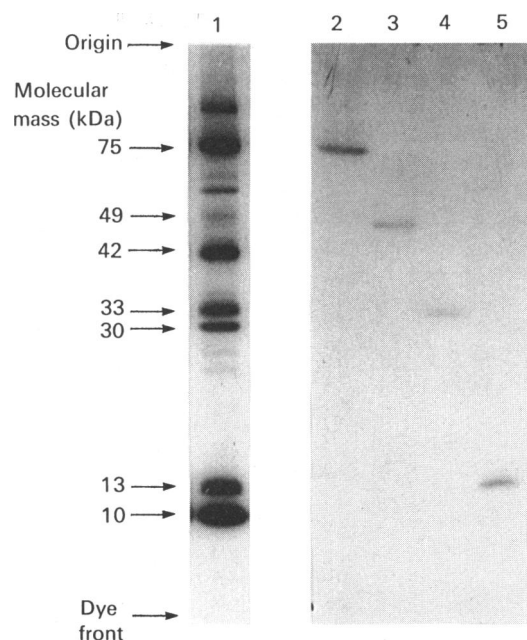

Fig. 8. Labelling of isolated Complex I with IDABS

Complex I was labelled with IDABS as described in the Materials and methods section. The labelled Complex I (track 1) or material immunoprecipitated from the Complex with antiserum to the 75 kDa subunit (track 2), the 49 kDa subunit (track 3), the 30 kDa subunit (track 4) or the 13 kDa subunit (track 5) was analysed by gel electrophoresis and autoradiography.

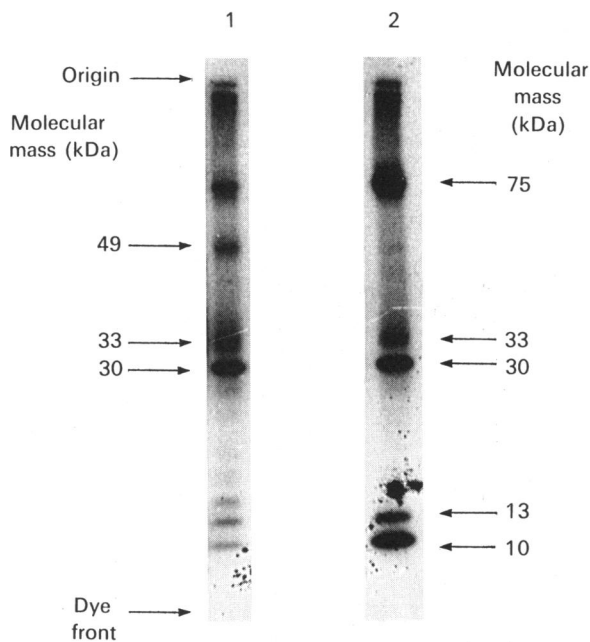

Fig. 9. Labelling of Complex I in mitochondria and submitochondrial particles with IDABS

Complex I was immunoprecipitated from IDABS-labelled mitochondria (track 1) and submitochondrial particles (track 2) as described in the Materials and methods section. Samples were analysed by gel electrophoresis and autoradiography.

If we assume that the mitochondrial- and submitochondrial-particle preparations were uniformly sided and that reaction with the probe is a measure of exposure, then these results suggest that the 33 and 30 kDa subunits are transmembranous, whereas the 75, 13 and 10 kDa subunits are mostly or wholly exposed on the matrix side of the membrane, and the 49 kDa subunit is mostly or wholly exposed on the cytoplasmic face.

These conclusions are in complete agreement with those based on the results of cross-linking experiments.

DISCUSSION

The observation that the 30 kDa subunit can be cross-linked to different subunits depending on the side of the membrane to which the cross-linker is added constitutes definite proof that this subunit is transmembranous. This conclusion is not affected by some degree of heterogeneity in the membrane preparations, since it is based on a qualitative, not quantitative, difference. The same is probably true of the 49 kDa subunit, which is clearly exposed on the cytoplasmic face of the membrane, where it is in contact with 30 and 19 kDa subunits, but also seems to protrude on the matrix side, where it contacts the 13 kDa subunit. However, the formation of the (49 + 13) kDa dimer was not as clearly dependent on the sidedness of the preparation. The 75 kDa and 51 kDa subunits are definitely exposed on the matrix side of the membrane, but the absence of cross-linked products containing either of these subunits after treatment of mitochondria does not prove that these subunits are solely exposed on the matrix side. A similar argument applies to the 19 kDa subunit. The agreement with the IDABS labelling is very striking, although the reliance in the labelling study on quantitative differences makes definitive identification of transmembranous proteins impossible. Furthermore, the labelling of Complex I subunits is very dependent on the type of probe used. In earlier studies with lactoperoxidase-catalysed iodination and diazobenzenesulphonate the labelling patterns were quite different [1]. In particular, rather more subunits of Complex I were labelled than with IDABS, with the exception of the 30 kDa protein, which failed to react. Despite these differences, it was concluded that the 75, 49 and 33 kDa subunits were transmembranous, in agreement with our present findings.

The discovery that DMS could act as a sided reagent was unexpected, and we attribute this to a rate of penetration rather slower than the rate of reaction, so

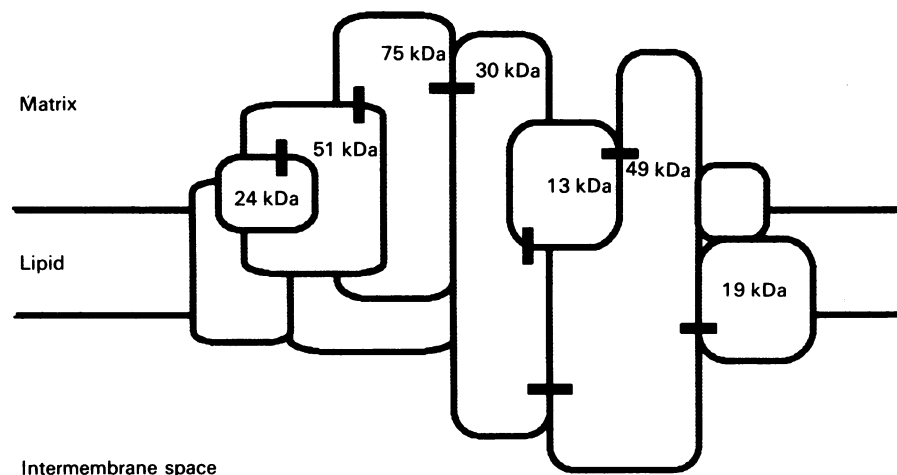

Scheme 1. Structure of Complex I: arrangement of Complex I subunits based on the results of this and the preceding paper [2]

The bold lines linking subunits (in kDa) indicate cross-links. Cross-linking of the 30 kDa and 13 kDa subunits was found with the isolated iron-protein fragment [17]. Cross-links to unidentified hydrophobic subunits are not shown.

that labelling on the side of reagent presentation was favoured. In support of this, labelling from both sides was evident at higher reagent concentration, although this could also be explained by loss of membrane integrity.

Our conclusions on the topology of Complex I subunits are shown diagrammatically in Scheme 1. Of particular significance is the transmembranous nature of the iron-protein fragment of the enzyme. This can be isolated in a soluble state from Complex I by treatment with chaotropic agents [16], and associations between the 75, 49, 30 and 13 kDa subunits are maintained. This has been demonstrated by their parallel immunoprecipitation by subunit-specific antisera [11] and by cross-linking of the isolated fragment [17]. When Complex I is photolabelled with probes partitioning into the membrane lipid, none of these subunits are labelled [18,19]. This fact, and the solubility of the fragment, make it very unlikely that this domain of the enzyme is in direct contact with the membrane lipid. Thus the model proposed originally by Hatefi and co-workers (see, e.g. [16]) and expanded by us in subsequent work [3], that the iron-protein domain is surrounded by a shell of hydrophobic proteins in the lipid phase of the membrane, is still valid.

This work was supported by research grants from the Science and Engineering Research Council.

REFERENCES

1. Smith, S. & Ragan, C. I. (1980) *Biochem. J.* **185**, 315–326
2. Patel, S. D. & Ragan, C. I. (1988) *Biochem. J.* **256**, 521–528
3. Ragan, C. I. (1987) *Curr. Top. Bioenerg.* **15**, 1–35
4. Crane, F. L., Glenn, J. L. & Green, D. E. (1956) *Biochim. Biophys. Acta* **22**, 475–487
5. Racker, E. (1962) *Proc. Natl. Acad. Sci. U.S.A.* **48**, 1659–1663
6. Blair, P. V. (1967) *Methods Enzymol.* **10**, 78–81
7. Hatefi, Y. & Reiske, J. S. (1967) *Methods Enzymol.* **10**, 235–239
8. Lowry, O. H., Rosebrough, N. J., Farr, A. L. & Randall, R. J. (1951) *J. Biol. Chem.* **193**, 265–275
9. Staros, J. V. (1981) *Biophys. J.* **27**, 21–22
10. Staros, J. V. (1982) *Biochemistry* **21**, 3950–3954
11. Ragan, C. I., Cleeter, M. W. J., Earley, F. G. P. & Patel, S. D. (1985) in *Achievements and Perspectives of Mitochondrial Research*, vol. 1: *Bioenergetics* (Quagliariello, E., Slater, E. C., Palmieri, F., Saccone, C. & Kroon, A. M., eds.), pp. 61–71, Elsevier, Amsterdam
12. Chen, S. & Guillory, R. J. (1981) *J. Biol. Chem.* **256**, 8318–8322
13. Wang, K. & Richards, F. M. (1974) *J. Biol. Chem.* **249**, 8005–8010
14. Earley, F. G. P., Patel, S. D., Ragan, C. I. & Attardi, G. (1987) *FEBS Lett.* **219**, 108–113
15. Cleeter, M. W. J. & Ragan, C. I. (1985) *Biochem. J.* **230**, 739–746
16. Hatefi, Y. & Stempel, K. E. (1969). *J. Biol. Chem.* **244**, 2350–2357
17. Cleeter, M. W. J., Banister, S. H. & Ragan, C. I. (1985) *Biochem. J.* **227**, 467–474
18. Earley, F. G. P. & Ragan, C. I. (1980) *Biochem. J.* **191**, 429–436
19. Earley, F. G. P. & Ragan, C. I. (1981) *FEBS Lett.* **127**, 45–47

Received 18 January 1988/1 June 1988; accepted 21 July 1988