

Incorporation of Exogenous Precursors into Uridine Nucleotides and Ribonucleic Acid

NUCLEOTIDE COMPARTMENTATION IN THE RENAL CORTEX *IN VIVO*

By Pedro CORTES,* Nathan W. LEVIN,* Francis DUMLER,*
Kumarapuram K. VENKATACHALAM,* Chacko P. VERGHESE* and Jay BERNSTEIN†

*Department of Medicine, Henry Ford Hospital, Detroit, MI 48202, U.S.A., and

†Department of Anatomic Pathology, William Beaumont Hospital, Royal Oak, MI 48072, U.S.A.

(Received 12 February 1979)

The possibility of compartmentation of UTP *in vivo* was investigated in the renal cortex of unanaesthetized rats. In addition, liver and spleen were studied in order to compare tissues with different utilization of precursors for pyrimidine nucleotide synthesis. After continuous 2 h infusions of [³H]uridine or [³H]orotate, their incorporation into UTP, UDP-sugars and RNA was quantified. Rates of RNA synthesis were calculated by dividing the incorporation of precursor into RNA by the average specific radioactivity of the UTP pool. Although similar RNA-synthesis rates might have been expected with the two precursors, higher rates were found with uridine than with orotate. The relative incorporation into UDP-sugars of these precursors was also different. Similar results were obtained in the liver. In the spleen, equal amounts of both precursors were incorporated into UTP, but [³H]orotate incorporation did not lead to labelling of RNA. To evaluate the heterogeneity of cells with respect to the metabolism of pyrimidines, precursor incorporation was studied in isolated glomeruli and by radioautography. Incorporation into glomeruli was qualitatively similar to but quantitatively different from results in the renal cortex. Although there is obvious tissue heterogeneity, compartmentation of UTP pools is the most credible explanation for the results obtained with the renal cortex and liver. Consequently RNA and UDP-sugars may originate from two different UTP pools. Tissue heterogeneity is the likely explanation for the results obtained in the spleen. Studies of synthesis of pyrimidine and RNA, particularly in relation to growth and regeneration, must take into consideration the precursor used, the apparent existence of UTP compartmentation and the degree of cellular heterogeneity.

Most mammalian cells actively synthesizing RNA possess two pathways for pyrimidine nucleotide synthesis, one for synthesis *de novo* and one salvage pathway. Orotate is commonly used as the precursor for the study of the former. Cells are highly permeable to orotate, hence its incorporation into the nucleotide pool depends on the rate of its subsequent conversion to UMP (Hauschka, 1973). Uridine, which is generally used for the study of the salvage pathway, is transported intracellularly by a facilitated diffusion system common to other nucleosides and is rapidly phosphorylated to UMP (Plageman *et al.*, 1978).

Radioactively labelled orotate and uridine have been used interchangeably to label uridine nucleotides and to study RNA synthesis *in vivo* and *in vitro* in animal cells or tissues. The degree of incorporation of these precursors into RNA varies widely for different tissues in the same animal (Witschi, 1972; Lewan *et al.*, 1975; Yngner *et al.*, 1977). The predominant incorporation of one over the other has largely determined the selection of the precursor to be used in studying a particular tissue or cell type.

It has been stressed repeatedly that quantification of the precursor pools is needed in the assessment of the rate of RNA synthesis as determined by incorporation rates of exogenous precursors (Harbers *et al.*, 1959; Emerson & Humphreys, 1971; Hauschka, 1973). When incorporation of label into RNA is corrected for changes in the specific radioactivity of the UTP precursor pool, the variables involved in cellular transport and isotope dilution in precursor pools are avoided (Bucher & Swaffield, 1969; Yu & Feigelson, 1970; Kalra & Wheldrake, 1972; Kaukel *et al.*, 1972; Cortes *et al.*, 1976). However, estimation of the rate of RNA synthesis could be subject to significant errors, if RNA were formed from a compartmented nucleotide precursor pool that was not in equilibrium with the main cellular nucleotide pool (Goody & Ellem, 1975). Evidence for a separate UTP pool, for example, from which rRNA is formed has been provided in isolated cells in culture (Plageman, 1971; Dämmgen & Scholtissek, 1975; Wieggers *et al.*, 1976). In contrast with this, other studies using similar techniques could not confirm the existence

of compartmented UTP or GTP pools in connection with RNA synthesis (Wu & Soeiro, 1971; Soeiro & Ehrenfeld, 1973; Dinauer & LaMarca, 1976). No previous attempts have been made to demonstrate UTP compartmentation in mammalian tissues *in vivo*.

The labelling characteristics and turnover rates of different classes of RNA have been extensively studied in the kidney (Hill, 1975; Melvin *et al.*, 1976; Ouellette & Malt, 1976). The kidney efficiently utilizes both exogenous uridine and orotate for RNA synthesis (Lewan *et al.*, 1975; Yngner *et al.*, 1977), but there are marked differences in the relative uptakes of these precursors in both the medullary and cortical regions (Toback *et al.*, 1974a,b; Liberti & Kline, 1974). These differences in uptake between cortex and medulla would seem to preclude the useful study of pyrimidine metabolism in the whole organ.

In this study, evidence has been sought for UTP compartmentation in the renal cortex of unanaesthetized rats. To this end, comparisons were made between the incorporation of orotate and that of uridine into UDP-sugars and RNA as related to the specific radioactivity of their common UTP precursor pool. To contrast the results obtained in the renal cortex with the results in other tissues having different degrees of precursor utilization, the studies were extended to include the liver and spleen from each animal.

Materials and Methods

Animals and surgical techniques

Male CDF rats, 158–196 g (Charles River Breeding Laboratories, Wilmington, MA, U.S.A.), were kept individually in circular cages and allowed free access to food and water. Permanent indwelling cannulae were inserted into the inferior vena cavae and brought out subcutaneously to the backs of the animals (Cortes *et al.*, 1976). The cannulae were taken out to the exterior of the cages through stainless-steel springs each weighing less than 5 g. This technique permitted the starting of intravenous infusions without handling the animals.

The animals were allowed 14 days to recover from surgery after which a mean increase of 36 g in weight was observed. Blood clotting within the cannulae was prevented by daily flushing with 0.2 ml of heparinized 0.15 M-NaCl.

Intravenous infusions

Unanaesthetized animals received continuous intravenous infusions at a rate of 10 μ l/min for 120 min (Sage 355 infusion pumps; Orion Research, Cambridge, MA, U.S.A.). One group of 10 animals received a total per animal of 0.3 mCi of [5-³H]-uridine and 50 nmol of uridine (sp. radioactivity of

mixture 6 Ci/mmol), and 10 animals in another group each received a total of 0.075 mCi of [5-³H]-orotic acid and 50 nmol of sodium orotate (sp. radioactivity of mixture 1.5 Ci/mmol) dissolved in 0.15 M-NaCl. Animals were anaesthetized with a mixture of methoxyfluorane and O₂ during the last 5 min of the infusion without interruption of flow, and tissue samples were obtained.

Tissue-handling and -extraction methods

Tissue specimens were collected without interfering with the blood supply, the main vessels to the organ being clamped after a portion of each was obtained. A rim of left renal cortex, a portion of liver and the spleen were cut and allowed to fall directly into liquid N₂. The samples were obtained in this order: first, renal cortex and spleen by left lumbotomy; second, liver by frontal laparotomy; third, a blood sample by cardiac puncture. In addition, a portion of the left renal cortex was fixed in formaldehyde for radioautographic examination, and the remainder of this kidney plus the whole right kidney were rapidly immersed in 0.15 M-NaCl at 2°C for glomerular isolation.

Contaminating blood in all specimens and any medullary portion remaining in the cortical specimens were scraped from the tissue to be studied under liquid N₂. Tissue samples weighing 300–400 mg were pulverized in a pre-cooled stainless-steel mortar and transferred to a beaker containing 0.2 M-HClO₄ and at 2°C. As an internal standard, 0.25 μ Ci of [2-¹⁴C]UTP was added for assessment of UTP recovery. The tissue was homogenized at 2°C, and the cold acid-soluble fraction was neutralized to pH 7.0 \pm 0.1 with 1 M-KOH in a Radiometer ABU-12 titrator (Radiometer, A/S Copenhagen, Denmark) and freeze-dried for later chromatographic analysis.

RNA was extracted from the remaining precipitate by alkaline hydrolysis in 0.3 M-KOH, and DNA by acid hydrolysis in 1 M-HClO₄ as previously described (Munro & Fleck, 1966).

Quantitative nucleotide analysis

The freeze-dried acid-soluble fractions were re-suspended in 0.2 ml of distilled water and centrifuged at 107 000 g for 30 min in a Beckman Airfuge (Beckman Instruments, Fullerton, CA, U.S.A.). Nucleotide analyses were carried out in duplicate on 20 μ l samples of the clear supernatant obtained after centrifugation.

Chromatographic analyses of nucleotides were carried out by a modification of methods previously described (Hartwick & Brown, 1975) using a Varian-8000 high-pressure liquid chromatograph (Varian Instruments, Palo Alto, CA, U.S.A.). Peaks were detected by simultaneous monitoring at 280 nm and at

245 or 262 nm and their areas quantified with Varian CDS-111 and Varian 485 electronic integrators. Chromatographic fractions were collected every 15 s for measurements of radioactivity.

Renal-cortical and splenic UTP were analysed in columns (4.6 cm × 25 cm) of Partisil-10 SAX (Whatman, Clifton, NJ, U.S.A.) that were eluted with 1.3 ml of buffer/min in a concave gradient formed initially by 5% (v/v) acetonitrile in 0.25 M-KH₂PO₄, pH 4.0, and finally by 1 M-KH₂PO₄, pH 4.8. Two columns in series were required for the analysis of hepatic UTP. Maximal differences between duplicate measurements of UTP were less than 10%; UTP recoveries varied between 62 and 73%. Analyses of UDP-sugars were carried out with two Partisil-10 SAX columns in series that were eluted at a rate of 2 ml/min with buffer in a concave gradient formed initially by 0.06 M-KH₂PO₄, pH 3.0, and finally by 1 M-KH₂PO₄, pH 3.3. UDP-glucose and UDP-galactose, eluted as a single peak, were quantified together and are referred to as UDP-sugars in this paper.

Glomerular isolation

Renal-cortical tissue from each experimental group was dissected from medullae, weighed and pooled. The renal cortices were minced and washed with 0.15 M-NaCl. Glomeruli were obtained by graded sieving with stainless-steel meshes of 120, 140 and 200 gauge used sequentially (Misra, 1972). The glomeruli recovered after the final sieving were concentrated by gravity, washed twice with 0.15 M-NaCl and separated from the suspension by centrifugation at 2000g and 2°C for 3 min. The entire isolation procedure was carried out at 2°C; preliminary experiments demonstrated identical recovery of glomerular RNA, DNA and protein after storage of the samples up to 3 h at 2°C. Portions (5 μl) of the final suspensions were examined by light microscopy for purity and determination of glomerular concentrations. Mean renal-cortical weight was 604 mg per kidney, yielding approx. 10.5 × 10³ glomeruli per cortex. The glomerular samples were homogenized at 2°C and the acid-soluble fractions obtained in 0.34 M-HClO₄. RNA, DNA and proteins were extracted and measured as described for the whole renal cortex.

Chemical methods and radioactivity measurements

RNA was measured by the orcinol reaction for quantification of ribose (McKay, 1964). With this method, 0.6 μg of ribose was equivalent to 1 μg of yeast RNA (type I, Sigma). DNA was measured by two methods: the first according to its u.v. absorption, by a two-wavelength method (Tsanev & Markov, 1960), and the second according to its deoxyribose

content, by the diphenylamine reaction (Giles & Myers, 1965). The latter gave results that were consistently 20% lower than the spectrophotometric method and was considered to be more specific; with it, 0.13 μg of deoxyribose were equivalent to 1 μg of calf thymus DNA (type I, Sigma). Protein was measured by the method of Lowry *et al.* (1951).

Plasma samples, acid-soluble fractions, RNA extracts and the collected chromatographic fractions were analysed for radioactivity by dual-isotope counting in a three-channel liquid-scintillation counter (LS-350 Beckman Instruments). Acidic samples were neutralized with 1 M-Tris base buffer before counting. A xylene-based commercial scintillator for aqueous samples was used (ACS; Amersham, Arlington Heights, IL, U.S.A.). Efficiency of counting was from 32 to 38% for ³H and from 58 to 75% for ¹⁴C.

Radioautography

Deparaffinized sections of formalin-fixed tissue were coated with NTB-2 emulsion which was exposed for 2 weeks at 4°C and then developed in Kodak Dektol for 2 min (Eastman-Kodak Co., Rochester, NY, U.S.A.). After clearing in Kodak Rapid-Fix, sections were stained with haematoxylin and eosin for light-microscopic examination (Baserga & Malamud, 1969).

Arbitrarily numbered sections of each kidney were examined without knowledge of the individual experimental procedures. The sections were examined under a 40X oil-immersion objective. Five glomeruli were chosen at random in each slide, and grains were counted within the boundaries of an eyepiece reticle. The totals were divided by the number of glomerular nuclei in the area encompassed by the reticle. Ten cross-sectional profiles of proximal tubule, identified by brush border, were randomly selected, except that the boundaries of the cross-section had to be clear for purposes of counting. The grains present in the tubular cells were counted and each total was divided by the number of nuclei in the tubular cross-section.

Standards and radiolabelled compounds

All standards were obtained from Sigma Chemical Co. (St. Louis, MO, U.S.A.). Mixtures of purified nucleotides were used as chromatographic standards. Solutions of yeast RNA and calf thymus DNA used to determine the pentose equivalence were prepared by the same extraction procedures as the tissue samples. Crystalline bovine serum albumin was used as standard for protein measurements.

Radiolabelled compounds were obtained from New England Nuclear Corp. (Boston, MA, U.S.A.). These included [³-H]orotic acid (sp. radioactivity

20Ci/mmol), [^3H]uridine (sp. radioactivity 20.3 Ci/mmol) and [^{14}C]UTP (sp. radioactivity 53.3 mCi/mmol). The radiochemical purity of the labelled UTP used as internal standard was 98%, as determined by high-pressure liquid chromatography.

Presentation of data and statistical analysis

RNA and DNA were quantified by their pentose content as determined by their respective colorimetric reactions. Incorporation values are presented as absolute d.p.m./mg of DNA or as a fraction of the d.p.m. infused/200 g body wt. per mg of tissue DNA. UTP-incorporation data were obtained as means of two consecutive chromatographic analyses after correcting for recovery of the UTP internal standard.

RNA-synthesis rate was calculated as the amount of UTP incorporated into RNA/h per mg of DNA [i.e. (d.p.m. incorporated into RNA/h per mg of DNA)/($\frac{1}{2} \times$ sp. radioactivity of UTP)] or per mg of protein (Bucher & Swaffield, 1969). The measurement of synthesis rate is based on one-half of the UTP specific radioactivity obtained at the end of the infusion period, which represents the mean value for the entire labelling period. This estimate of mean specific radioactivity is warranted, since incorporation of exogenous precursor into renal cortex or liver UTP increases linearly during the period of continuous infusion (Bucher & Swaffield, 1969; Cortes *et al.*, 1976).

Results are presented as means \pm S.E.M. with the numbers of observations in parentheses. The statistical significance between group means was determined by the unpaired Student's *t* test.

Results

UTP, UDP-sugars, RNA and DNA content in renal cortex, liver and spleen

Concentrations of DNA in the renal cortex, liver and spleen were 0.452 ± 0.005 (20), 0.311 ± 0.005 (20) and 1.51 ± 0.04 (20) mg/g of tissue respectively. DNA

content was not affected by the kind of infusion used. Mean glomerular content of DNA was 1.46 ng/glomerulus. RNA content of the renal cortex was substantially lower than that of liver when expressed per unit of DNA or protein (Table 1). Glomerular RNA represented only a small fraction of the total renal-cortical RNA as derived from the estimated 30×10^3 glomeruli present in the rat renal cortex (Arataki, 1926; Rouffignac & Monnens, 1976; Solomon, 1977) and from the 70 mg of protein per cortex and $0.072 \mu\text{g}$ of protein per glomerulus, which were the mean values found in this study. According to this calculation, glomerular RNA represents 5% and glomerular protein 3% of the total respective amounts found in the renal cortex.

Contents of RNA, UTP and UDP-sugars in the renal cortex, liver and spleen were markedly different in the three tissues studied (Table 1). Liver had the highest ratios of UTP/DNA, with values 60% higher than in the renal cortex and 7 times the amount found in the spleen. There were 4–6-fold differences in the content of UDP-sugars among the three tissues studied, the highest values being in the liver and the lowest in the spleen.

Distribution of label in renal-cortical uridine phosphates after infusion of [^3H]orotate or [^3H]uridine

At the completion of 2 h continuous intravenous infusions of labelled precursors, 0.52 ± 0.02 (8) % of the total [^3H]uridine and 0.09 ± 0.003 (10) % of the total [^3H]orotate infused were found/ml of plasma.

To study the efficiency of the two precursors in labelling uridine phosphates, pooled samples of cortical acid-soluble extracts were analysed. Radioactivity found in these extracts as orotate or uridine was excluded from the calculations, because of the contaminating effect of plasma present in the tissue. Almost 100% of the acid-extractable radioactivity in the group infused with [^3H]uridine and 96% in the group infused with [^3H]orotate was recovered as uridine phosphates or as the main UDP-sugars

Table 1. Tissue content of RNA, UTP and UDP-sugars in renal cortex, liver, spleen and of RNA in isolated glomeruli. Tissue values were obtained in samples rapidly frozen in liquid N_2 . Values are presented as means \pm S.E.M. for 20 animals. Glomerular values were obtained in glomeruli separated at 2°C , and are means \pm S.E.M. for four separate glomerular preparations, each originated from the pooled renal cortices of four to five animals.

	RNA (mg)		UTP (nmol)		UDP-glucose+UDP-galactose (nmol)	
	(per mg of DNA)	(per g of protein)	(per mg of DNA)	(per mg of protein)	(per mg of DNA)	(per mg of protein)
Renal cortex	1.63 ± 0.02	6.37 ± 0.07	441 ± 13	1.72 ± 0.05	368 ± 7	1.44 ± 0.03
Glomeruli	0.624 ± 0.056	11.1 ± 0.54	—	—	—	—
Liver	4.67 ± 0.07	8.83 ± 0.17	707 ± 38	1.38 ± 0.07	2285 ± 68	4.31 ± 0.12
Spleen	0.614 ± 0.022	8.20 ± 0.25	112 ± 4	1.50 ± 0.05	97.6 ± 0	1.31 ± 0.04

and UDP-amino sugars. Less than 1% of the total radioactivity was incorporated into CTP and orotidine 5'-phosphate.

Distribution of label among the main derivatives of uridine appeared to be similar regardless of the precursor used for the infusion, the differences obtained being 3% or less (Table 2).

Table 2. Distribution of label in the pyrimidine nucleotides of renal cortex after continuous infusions of [^3H]uridine or [^3H]orotate as precursors

Samples of renal cortex were obtained at the end of continuous 2h infusions in 10 animals receiving [^3H]orotate and in eight animals receiving [^3H]uridine. Portions of tissue acid-soluble extracts were pooled and a 20 μl sample was taken for chromatographic analysis. The radioactivity found in each chromatographic peak was quantified and expressed as a percentage of the total radioactivity contained in the sample used for analysis. In order to exclude the error caused by the plasma radioactivity contained in the tissue specimen, the radioactivity incorporated as [^3H]uridine or [^3H]orotate was omitted from the calculations obtained from animals infused with the corresponding labelled precursors.

	Percentage of total radioactivity	
	[^3H]Uridine infusion	[^3H]Orotate infusion
Uridine	—	2.2
UMP	16.3	14.0
UDP	18.5	19.7
UTP	24.0	21.0
UDPG+UDP-galactose	20.8	22.6
UDP-acetylglucosamine+UDP-glucuronic acid	20.0	18.3
Total	99.6	97.8

Incorporation of infused [^3H]orotate or [^3H]uridine into UTP, UDP-sugars and RNA in the renal cortex, liver and spleen

The incorporation of [^3H]orotate or [^3H]uridine was studied in individual samples of acid-soluble extracts of renal cortex, liver and spleen. Renal cortex and liver differed in the degree of labelling of UTP and UDP-sugars. [^3H]Orotate labelled UTP and UDP-sugars to a similar extent in the renal cortex, but in the liver UDP-sugars were labelled to a greater degree than was UTP ($P < 0.001$) (Table 3). Similar results were obtained with [^3H]uridine.

At the completion of the infusions the amount of orotate incorporated into UTP, UDP-sugars and RNA was significantly greater than that of uridine ($P < 0.001$) in both renal cortex and liver (Table 3). In addition, uridine incorporation was less in the liver than in the kidney, so that hepatic UTP labelling was only one-seventh of the value of renal UTP labelling.

Incorporation of both orotate and uridine into RNA was greater in the renal cortex than in the liver. However, when incorporation into RNA was divided by the incorporation into UTP, a significantly greater ratio was obtained with uridine as precursor than with orotate in both tissues (Table 3). Uridine appears therefore to be incorporated into RNA more efficiently than orotate for a given degree of UTP labelling.

The labelling characteristics of UTP, UDP-sugars and RNA in the spleen were in sharp contrast with the results obtained in the renal cortex and liver. In the spleen, the incorporation of orotate and uridine into UTP was identical. Orotate incorporation into UDP-sugars and RNA was minimal, but uridine was incorporated into both UDP-sugars and RNA (Table 3). These results suggest that the fraction of

Table 3. Incorporation of [^3H]orotate or [^3H]uridine into RNA, UTP and UDP-sugars in renal cortex, liver and spleen after a continuous infusion with them

Samples of renal cortex, liver or spleen were obtained from ten animals receiving [^3H]orotate and from eight animals receiving [^3H]uridine. The amount of radioactivity incorporated was expressed as the percentage of the total radioactivity infused per mg of DNA in the tissue samples. Values are presented as means \pm S.E.M.

	Fractional incorporation (% of d.p.m. infused/mg of DNA)			
	UTP	UDP-Glucose+UDP-galactose	RNA	RNA/UTP
Renal cortex				
[^3H]Orotate	4.77 \pm 0.21	4.54 \pm 0.26	3.54 \pm 0.13	0.746 \pm 0.017
[^3H]Uridine	0.123 \pm 0.010*	0.101 \pm 0.009*	0.127 \pm 0.009*	0.974 \pm 0.042*
Liver				
[^3H]Orotate	2.03 \pm 0.13	7.08 \pm 0.46	1.56 \pm 0.10	0.773 \pm 0.025
[^3H]Uridine	0.0176 \pm 0.0011*	0.0351 \pm 0.0031*	0.0234 \pm 0.0009*	1.37 \pm 0.11*
Spleen				
[^3H]Orotate	0.0231 \pm 0.0044	0.0087 \pm 0.0016	< 0.004	—
[^3H]Uridine	0.0268 \pm 0.0022	0.022 \pm 0.002*	0.0406 \pm 0.004	1.56 \pm 0.15

* Significance of difference between result for [^3H]orotate and [^3H]uridine, $P < 0.001$.

the splenic UTP that was labelled with [^3H]orotate could not be further processed into UDP-sugars or RNA.

Calculated RNA-synthesis rate in the renal cortex, liver and spleen after infusion of [^3H]orotate or [^3H]uridine

The calculated rate of renal-cortical RNA synthesis with uridine as precursor was significantly greater than with orotate as precursor. Expressing the results per unit of DNA or per unit of protein did not affect the observed differences (Table 4). Similar results were obtained in the calculated rates of RNA synthesis in the liver (Table 4). RNA-synthesis rate per unit of DNA was significantly higher ($P < 0.001$) in the liver than in the renal cortex when data obtained with the same precursors were compared.

The calculated rate of splenic RNA synthesis with uridine was the lowest for the three tissues studied with this precursor when expressed per unit of DNA (Table 4). No comparisons could be made after labelling with [^3H]orotate, since the incorporation of this precursor into RNA was negligible.

Specific radioactivity of the pool of UDP-sugars in the renal cortex, liver and spleen after infusion of [^3H]orotate or [^3H]uridine

The specific radioactivity of the UDP-sugar pool was severalfold higher in the renal cortex than in the liver with both precursors (Table 4). However, in both tissues there were differences between [^3H]-

orotate and [^3H]uridine in the labelling of UDP-sugars. When the specific radioactivity of the UDP-sugar pool was related to the specific radioactivity of the UTP pool from which it originated, a significantly greater value was obtained with orotate than with uridine (Table 4). These results are consistent with more efficient incorporation of orotate than uridine into UDP-sugars for a given specific radioactivity of the UTP pool.

Incorporation of [^3H]orotate or [^3H]uridine into the glomerular acid-soluble fraction and RNA

To investigate differences in the handling of exogenous RNA precursors between distinct morphological areas within the renal cortex, the labelling of RNA was studied in isolated glomeruli. The amount of label found in the glomerular acid-soluble fraction was assumed to be equivalent to the amount of precursor incorporated into the total uridine phosphate pool. In contrast with the limitations encountered in studying the whole renal cortex, contaminating plasma and non-incorporated precursor were removed from the glomeruli during the procedure for glomerular isolation.

The incorporation of label into RNA, expressed as absolute amount of radioactivity or as specific radioactivity, was greater with uridine than with orotate (Table 5). Since the specific radioactivity of infused [^3H]uridine was 4 times that of [^3H]orotate, this finding was expected. When the incorporation of precursor was expressed as a fraction of the total infused, orotate was incorporated more efficiently into uridine phosphates and RNA than was uridine (Table 5).

Table 4. Specific radioactivity of the UTP and UDP-sugar pools and calculated RNA-synthesis rate in the renal cortex, liver and spleen after a continuous infusion of [^3H]orotate or [^3H]uridine

Values were obtained in the same samples as in Table 3 and are presented as means \pm S.E.M.

	$10^{-2} \times \text{Sp. radioactivity (d.p.m./nmol)}$			RNA-synthesis rate (nmol of UTP incorporated/h)	
	UTP	UDP-glucose+ UDP-galactose	UDP-glucose+ UDP-galactose/UTP	(per mg of DNA)	(per mg of protein)
Renal cortex					
[^3H]Orotate	189 \pm 6	218 \pm 11	1.15 \pm 0.05‡	331 \pm 9	1.27 \pm 0.04
[^3H]Uridine	16.2 \pm 2.1*	15.4 \pm 2.1*	0.956 \pm 0.038‡	425 \pm 9*	1.69 \pm 0.03*
Liver					
[^3H]Orotate	46.4 \pm 4.6	55.7 \pm 4.2	1.12 \pm 0.04	527 \pm 16	1.05 \pm 0.04
[^3H]Uridine	1.67 \pm 0.19*	0.988 \pm 0.089*	0.650 \pm 0.110†	961 \pm 118*	1.83 \pm 0.22*
Spleen					
[^3H]Orotate	4.66 \pm 0.68	1.55 \pm 0.26	0.368 \pm 0.056	—	—
[^3H]Uridine	13.8 \pm 0.9*	13.0 \pm 1.3*	1.38 \pm 0.10‡	181 \pm 9	2.20 \pm 0.15

* Significance of difference between result for [^3H]orotate and [^3H]uridine, $P < 0.001$.

† $P < 0.005$.

‡ $P < 0.025$.

Table 5. Incorporation of [^3H]orotate or [^3H]uridine into glomerular nucleotides and RNA after a continuous infusion with them. Renal cortices obtained from one and one-third kidneys per rat in animals infused with [^3H]orotate or [^3H]uridine were pooled into four separate samples and their glomeruli isolated. Precursor incorporation into RNA or into the acid-soluble glomerular extract was expressed as the percentage of the total radioactivity infused per mg of glomerular DNA. Values presented correspond to data obtained in pooled glomeruli from four to five animals.

	$10^{-3} \times$ Total incorporation (d.p.m./mg of DNA)		Fractional incorporation (% of d.p.m. infused/mg of DNA)			$10^{-3} \times$ Sp. radioactivity of RNA (d.p.m./mg)
	Uridine phosphates	RNA	Uridine phosphates	RNA	RNA/uridine phosphates	
[^3H]Orotate	777	215	0.421	0.117	0.28	404
	792	283	0.429	0.153	0.36	544
[^3H]Uridine	497	427	0.071	0.061	0.86	613
	456	439	0.065	0.063	0.97	589

Table 6. Glomerular and proximal-tubular cell labelling after a continuous infusion of [^3H]orotate or [^3H]uridine

Cellular uptake of labelled precursors was assessed by radioautographic study of renal-cortex specimens obtained from the same animals as were used in the experiments described in Table 3. Results are presented as means \pm s.e.m. of the number of grains counted per cell. Individual values were obtained in 200–400 glomerular cells or in 70–110 tubular cells. A total of ten and eight renal cortices labelled with [^3H]orotate or [^3H]uridine respectively were examined.

	Cellular labelling (grains/nucleus)	
	[^3H]Orotate infusion	[^3H]Uridine infusion
Glomeruli	0.342 \pm 0.065	1.01 \pm 0.06
Proximal tubule	13.0 \pm 1.2	2.51 \pm 0.21
Tubuloglomerular ratio	51.6 \pm 9.8	2.55 \pm 0.28*

* Significance of difference, $P < 0.001$.

The incorporation of orotate into RNA was one-third of that of uridine when the observed values were divided by those for incorporation into the total precursor pool of uridine phosphates (Table 5). Consequently uridine appears to be incorporated into glomerular RNA more efficiently than orotate for a given degree of labelling of uridine phosphates.

Proximal-tubular and glomerular cell labelling after infusion of [^3H]orotate or [^3H]uridine

Differences in cellular uptake of [^3H]orotate and [^3H]uridine in separate anatomical regions of the renal cortex were studied by radioautographic techniques. The proximal tubule and the glomerulus were selected for study as two easily identifiable major histological components. The intensity of cellular labelling would be expected to depend on the absolute amount of radioactivity infused. [^3H]Uridine infusion therefore should have yielded greater cellular

labelling than [^3H]orotate infusion throughout the renal cortex, assuming identical cellular uptake of precursor in all areas. Glomerular cells were labelled to a greater extent by [^3H]uridine than by [^3H]orotate. Proximal-tubular cells were labelled more than the glomerular cells by both precursors. However, labelling of these tubular cells with [^3H]orotate was 6 times greater than with uridine (Table 6). Thus a significantly different tubuloglomerular ratio of cellular uptake was obtained when the two precursors were compared.

Visual inspection seemed to show greater uptake of [^3H]uridine than of [^3H]orotate in the distal nephron, but quantitative assessment was not attempted because of difficulties in the precise identification of different segments of the nephron and therefore in the randomization of microscopic fields.

Discussion

This study confirms the greater uptake of orotate than of uridine by both renal cortex and liver (Lewan *et al.*, 1975; Yngner *et al.*, 1977). However, there were differences between these tissues in the incorporation of labelled precursors into pyrimidine nucleotides and RNA. Uridine, and to a lesser degree orotate, were incorporated into UTP and RNA to a greater extent in the renal cortex than in the liver. More labelled orotate was incorporated into UDP-sugars in the liver than in renal cortex. This efficient incorporation and the existence of a larger hepatic UDP-sugar pool is likely to be related to the greater synthesis of glycogen in the liver than in the renal cortex (Hers, 1976).

Extracellular labelled precursors must enter the cell and mix with intracellular pools of intermediates before being converted to the nucleoside triphosphates, which are the immediate precursors of RNA. Since equilibration of these pools cannot be assured (Hauschka, 1973), quantitative measurement of RNA

synthesis requires determination of both the specific radioactivity of the pool of nucleotide triphosphate precursor of RNA and the amount of label incorporated into RNA. RNA synthesis, expressed as the rate of UTP incorporation into RNA, should be identical, regardless of the precursor used to label UTP, but in this study clearly dissimilar values were obtained with [³H]uridine and [³H]orotate, although both were utilized efficiently for labelling of RNA (Tables 3 and 4). These observations indicate that the specific radioactivity of the total UTP pool used for the calculation of RNA synthesis does not correspond to the specific radioactivity of the pool involved in the formation of RNA. These results suggest the presence of a separate UTP pool that is readily available for RNA synthesis and that preferentially accumulates exogenous uridine.

Since UTP is the immediate precursor of CTP, incorporation of labelled CTP into RNA could result in an overestimation of the RNA-synthesis rate. However, the specific radioactivity of the renal CTP pool labelled with [³H]orotate or [³H]uridine is only a small fraction of the specific radioactivity of the UTP pool (P. Cortes & N. W. Levin, unpublished work). Therefore the amount of radioactivity in RNA due to its content of labelled cytidine is probably not a significant source of error in calculating RNA-synthesis rate with either of the labelled precursors when continuous intravenous infusion is used.

Labelling of UDP-sugars in the renal cortex and liver was accomplished more efficiently with [³H]-orotate than with [³H]uridine (Table 4), suggesting that radioactivity in UDP-sugars originates from a separate UTP pool into which exogenous orotate is incorporated preferentially.

The method used in this study for labelling of nucleotides might be expected to be inadequate for demonstrating compartmentation of the UTP pool, since ample time for equilibration between pools is allowed by continuous infusion of labelled precursor. Despite this and the differences in the relative labelling of UTP in renal cortex and liver (Table 3), similar evidence for compartmentation was found in both tissues. If the study of the utilization of precursors had consisted merely of analysing the distribution of radioactivity among the different nucleotides in acid-soluble tissue extracts, it might have been concluded that there was similar utilization of the exogenous precursors in the synthesis of UTP and UDP-sugars (Table 2). Hence this mode of analysis seems to be insufficient to assess changes in pyrimidine metabolism.

The renal cortex contains functionally dissimilar segments of the nephron that might also be dissimilar in their uptake of pyrimidine precursors and in UTP utilization (Ross *et al.*, 1975). Tissue heterogeneity therefore offers an alternative interpretation of the discordant results obtained in this study.

The spleen, containing a diversity of cell types, may provide evidence for the effect of tissue heterogeneity on studies of pyrimidine metabolism. Uridine was incorporated into splenic UTP to the same extent as was orotate and efficiently labelled UDP-sugars and RNA. However, UTP labelled by orotate was barely utilized for the synthesis of UDP-sugars and RNA (Table 3). These findings might be explained by dissimilar pyrimidine metabolism in different cells. For example, erythrocytes, which form a major cellular component, can transport but not phosphorylate uridine (Lieu *et al.*, 1971; Pickard & Paterson, 1972). In contrast, erythrocytes utilize exogenous orotate for the synthesis of nucleotides, even though they lack the enzymes to form pyrimidines *de novo* and cannot synthesize RNA (Smith & Baker, 1959; Fox *et al.*, 1978). Lymphoid cells, which form the bulk of the spleen, cannot utilize exogenous orotate but efficiently transport and phosphorylate uridine for RNA synthesis (Forsdyke, 1968). Thus the results obtained in studies on the spleen may reflect the presence of two cell populations: one incorporating orotate into UTP but unable to synthesize RNA, the other incorporating uridine into UTP and RNA but unable to utilize orotate. The handling of exogenous precursors by the renal cortex and liver is therefore quite different from their handling by the spleen.

The utilization of precursors by the glomerulus was similar to that of the entire renal cortex. Orotate was incorporated more efficiently than uridine into nucleotides and RNA, and nucleotides labelled with [³H]uridine were comparatively more efficient precursors for RNA synthesis (Table 5). Compartmentation of UTP therefore also possibly occurs in the glomerular cells. However, there were quantitative differences between whole cortex and isolated glomeruli in their proportional utilization of precursors. When results obtained with the two precursors are compared, glomeruli incorporated uridine into RNA relatively more efficiently than did cortex (Tables 3 and 5), and the uptake of orotate by proximal-tubular cells was comparatively higher than the uptake by glomerular cells, as demonstrated by radioautography (Table 6). Thus not all cells in the renal cortex are identical in their use of exogenous UTP precursors.

The degree of cellular heterogeneity with regard to the uptake of pyrimidine precursors in the liver is unknown. Hepatocytes arranged in lobules form the bulk of the liver mass (Preisig *et al.*, 1972), and orotate injected *in vivo* is uniformly distributed throughout the tissue (Loeb & Yeung, 1975). However, several studies have reported heterogeneity in the lobular distribution of a number of hepatic metabolic functions (Welsh, 1972; Babcock & Cardell, 1974; Katz *et al.*, 1977), and fine structural differences have been found between peripheral

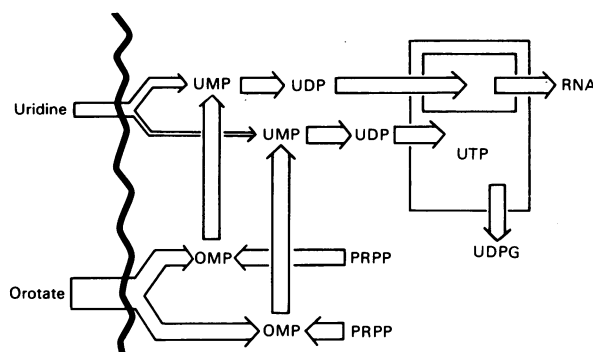

Scheme 1. *Theoretical model of UTP compartmentation*

OMP, orotidine 5'-phosphate; PRPP, 5'-phosphoribosyl pyrophosphate; UDPG, uridine 5'-diphosphoglucose.

and centrolobular hepatocytes (Schmucker *et al.*, 1978).

Previous studies of liver slices have produced evidence for the existence of separate UMP pools (Tseng & Gurside, 1973), and compartmentation of uridine phosphate pools has been hypothesized to occur in regenerating liver (Bucher & Swaffield, 1966). Results from kinetic studies on the incorporation of uridine into UTP and RNA in rat hepatoma cells have indicated the presence of at least two UTP pools, only one of which serves as a source for RNA synthesis (Plageman, 1971; Khym *et al.*, 1978).

Although some degree of cellular heterogeneity is present in the renal cortex and is also likely to exist in the liver, intracellular compartmentation in these tissues is the most likely explanation of the results described in this study. Several models of intracellular UTP compartmentation conform to the results obtained. One of those in which all uridine phosphate pools appear to be compartmented is depicted in Scheme 1. This model is in keeping with previous evidence for UMP compartmentation and with the presence of two forms of hepatic uridine kinase (Krystal & Webb, 1971; Tseng & Gurside, 1973; Keefer *et al.*, 1975).

The observations described in the present work are of significance in the study of tissue growth and in the investigation of the consequences of inhibition of pyrimidine synthesis in RNA formation. The total UTP pool increases during tissue regeneration (Bucher & Swaffield, 1969; Cortes *et al.*, 1976) after administration of large quantities of pyrimidine precursors (von Euler *et al.*, 1963) and is probably altered by inhibitors of enzymes involved in the synthesis *de novo* of pyrimidines (Vesely *et al.*, 1968; Traut & Jones, 1977). In these and other situations in which the total UTP pool is likely to be altered (Mandel, 1964), the change may not be proportional in all the different UTP pools. This would result in variable dilution of individual labelled precursors

incorporated at different rates into separate UTP pools and modify the amount of label incorporated in RNA. Thus rates of RNA synthesis would be calculated which would not reflect actual changes in synthesis rate.

We thank Mr. K. M. Adams and Mr. S. Sastri for their excellent technical assistance and Ms. M. Dode for expert secretarial help. This work was supported by research grants from the Kidney Foundation of Michigan (grant 76R017), the Juvenile Diabetes Foundation (project R38811), with funds supplied by Henry Ford Hospital via a Ford Foundation grant and by a grant from William Beaumont Hospital Research Institute.

References

- Arataki, M. (1926) *Am. J. Anat.* **36**, 399-436
 Babcock, M. B. & Cardell, R. R. (1974) *Am. J. Anat.* **140**, 299-338
 Baserga, R. & Malamud, D. (1969) in *Modern Methods in Experimental Pathology: Autoradiography: Techniques and Application*, pp. 17-69, Harper and Row, New York, Evanston and London
 Bucher, N. L. & Swaffield (1966) *Biochim. Biophys. Acta* **129**, 445-459
 Bucher, N. L. & Swaffield (1969) *Biochim. Biophys. Acta* **174**, 491-502
 Cortes, P., Levin, N. W. & Martin, P. R. (1976) *Biochem. J.* **158**, 457-470
 Dämmgen, J. W. & Scholtissek, C. (1975) *Eur. J. Biochem.* **59**, 51-54
 Dinauer, M. C. & LaMarca, M. J. (1976) *Exp. Cell Res.* **101**, 122-126
 Emerson, C. P., Jr. & Humphreys, T. (1971) *Anal. Biochem.* **40**, 254-266
 Forsdyke, D. R. (1968) *Biochem. J.* **107**, 197-205
 Fox, I. H., Burk, L., Planet, G., Goren, M. & Kaminska, J. (1978) *J. Biol. Chem.* **253**, 6794-6800
 Giles, K. W. & Myers, A. (1965) *Nature (London)* **206**, 93
 Goody, H. E. & Ellem, K. A. O. (1975) *Biochim. Biophys. Acta* **383**, 30-39

- Harbers, E., Chaudhuri, N. K. & Heidelberger, C. (1959) *J. Biol. Chem.* **234**, 1255-1262
- Hartwick, R. A. & Brown, P. R. (1975) *J. Chromatogr.* **112**, 651-662
- Hauschka, P. V. (1973) *Methods Cell Biol.* **7**, 361-462
- Hers, H. G. (1976) *Annu. Rev. Biochem.* **44**, 167-189
- Hill, J. M. (1975) *J. Cell Biol.* **64**, 260-265
- Kalra, J. & Wheldrake, J. F. (1972) *FEBS Lett.* **25**, 298-300
- Katz, N., Teutsch, H. F., Sasse, D. & Jungermann, K. (1977) *FEBS Lett.* **76**, 226-230
- Kaukel, E., Fuhrmann, U. & Hiltz, H. (1972) *Biochem. Biophys. Res. Commun.* **48**, 1516-1524
- Keefer, R. C., McNamara, D. J. & Webb, T. E. (1975) *Cancer Biochem. Biophys.* **1**, 107-110
- Khym, J. X., Jones, M. H., Lee, W. H., Regan, J. D. & Volkin, E. (1978) *J. Biol. Chem.* **253**, 8741-8746
- Krystal, G. & Webb, T. E. (1971) *Biochem. J.* **124**, 943-947
- Lewan, L., Petersen, I. & Yngner, T. (1975) *Hoppe-Seyler's Z. Physiol. Chem.* **356**, 425-429
- Liberti, J. P. & Kline, E. S. (1974) *Life Sci.* **15**, 1815-1826
- Lieu, T. S., Hudson, R. A., Brown, R. K. & White, B. C. (1971) *Biochim. Biophys. Acta* **241**, 884-893
- Loeb, J. N. & Yeung, L. L. (1975) *J. Exp. Med.* **142**, 575-587
- Lowry, O. H., Rosebrough, N. J., Farr, A. L. & Randall, R. J. (1951) *J. Biol. Chem.* **193**, 265-275
- Mandel, P. (1964) *Prog. Nucleic Acid Res. Mol. Biol.* **3**, 299-334
- McKay, E. (1964) *Clin. Chim. Acta* **10**, 320-329
- Melvin, W. T., Kumar, A. & Malt, R. A. (1976) *J. Cell Biol.* **69**, 548-556
- Misra, R. P. (1972) *Am. J. Clin. Pathol.* **58**, 135-139
- Munro, H. N. & Fleck, A. (1966) *Methods Biochem. Anal.* **14**, 113-176
- Ouellette, A. J. & Malt, R. A. (1976) *Biochemistry* **15**, 3358-3361
- Pickard, M. A. & Paterson, A. R. P. (1972) *Can. J. Biochem.* **50**, 704-705
- Plageman, P. G. W. (1971) *J. Cell. Physiol.* **77**, 241-258
- Plageman, P. G. W., Marz, R. & Wohlhueter, R. M. (1978) *J. Cell. Physiol.* **97**, 49-72
- Preisig, R., Bircher, J. & Paumgartner, G. (1972) *Prog. Liver Dis.* **4**, 201-216
- Ross, J. S., Malamud, D., Caulfield, J. B. & Malt, R. A. (1975) *Am. J. Physiol.* **229**, 952-954
- Rouffignac, C. & Monnens, L. (1976) *J. Physiol. (London)* **262**, 119-129
- Schmucker, D. L., Mooney, J. S. & Jones, A. L. (1978) *J. Cell Biol.* **78**, 319-337
- Smith, L. H. & Baker, F. A. (1959) *J. Clin. Invest.* **38**, 798-809
- Soeiro, R. & Ehrenfeld, E. (1973) *J. Mol. Biol.* **77**, 177-187
- Solomon, S. (1977) *J. Physiol. (London)* **272**, 573-589
- Toback, F. G., Smith, P. D. & Lowenstein, L. M. (1974a) *Am. J. Physiol.* **226**, 1474-1479
- Toback, F. G., Smith, P. D. & Lowenstein, L. M. (1974b) *Proc. Soc. Exp. Biol. Med.* **146**, 222-224
- Traut, T. W. & Jones, M. E. (1977) *Biochem. Pharmacol.* **26**, 2291-2296
- Tsanev, R. & Markov, G. G. (1960) *Biochim. Biophys. Acta* **42**, 442-452
- Tseng, J. K. & Gurrpide, E. (1973) *J. Biol. Chem.* **248**, 5634-5640
- Vesely, J., Cihák, A. & Sörm, F. (1968) *Biochem. Pharmacol.* **17**, 519-524
- von Euler, L. H., Rubin, R. J. & Handschumacher, R. E. (1963) *J. Biol. Chem.* **238**, 2464-2469
- Welsh, F. (1972) *J. Histochem. Cytochem.* **20**, 107-111
- Wieggers, U., Kramer, G., Klapproth, K. & Hiltz, H. (1976) *Eur. J. Biochem.* **64**, 535-540
- Witschi, H. (1972) *Cancer Res.* **32**, 1686-1694
- Wu, R. S. & Soeiro, R. (1971) *J. Mol. Biol.* **58**, 481-487
- Yngner, T., Petersen, I. & Lewan, L. (1977) *Int. J. Biochem.* **8**, 395-401
- Yu, F. L. & Feigelson, P. (1970) *Arch. Biochem. Biophys.* **141**, 662-667