

A Sensitive and Accurate Gel Osmometer

By A. G. OGSTON and B. N. PRESTON

Department of Biochemistry, University of Oxford, Oxford OX1 3QU, U.K.

(Received 7 November 1972)

1. A bilayer strip, cut from a thin layer of cross-linked polyacrylamide gel cast on to cellulose tissue, forms an open circular loop whose ends are close together. Shrinkage of the gel, in response to the osmotic pressure of a non-penetrating solution, causes a proportional separation of the ends of the loop. This is measured with a microscope and micrometer eyepiece. 2. The resulting effective sensitivity is about 30 times that of the Sephadex-bead osmometer (Ogston & Wells, 1970), i.e. of the order of 5 Pa, comparable with that of a membrane osmometer. Use of gel up to 70% (w/v) allows the measurement of molecular weights, as low as 1500 in favourable cases, with an accuracy of 1-2%. The useful range of osmotic pressure is up to 5 kPa. A single measurement requires 0.5 ml of solution. Equilibration is completed in 20-30 min. 3. The method is illustrated by measurements on human serum albumin, ovalbumin, cytochrome *c*, samples of dextrans, polyvinyl alcohol, and polyethylene glycols 6000 and 1000.

Edmond *et al.* (1968) and Ogston & Wells (1970) described the measurement of colloid osmotic pressure by use of single beads of Sephadex. As Ogston & Wells (1970) pointed out, the method, though suitable for the measurement of high osmotic pressures in solutions of macromolecules of large molecular weight, is not useful for more dilute solutions or for lower-molecular-weight solutes, for two reasons: (1) Sephadex G-50, the most highly cross-linked grade of Sephadex that can be used, is significantly permeable to proteins of molecular weight less than about 100000; (2) the precision with which the bead diameter can be measured (about 0.3 μm) corresponds to an error of about 150 Pa of osmotic pressure, which, for example, is nearly one-half the osmotic pressure of a 1% (w/v) solution of serum albumin.

If the method is to be comparable in precision and range of usefulness with membrane osmometry, both a less-permeable gel than Sephadex G-50 and a greatly increased sensitivity are required. We have achieved both objects. Following a suggestion of Dr. C. W. McCutchen (personal communication) and the indications of the chromatographic experiments of Morris & Morris (1971), we have used cross-linked polyacrylamide gel to make bilayer strips of gel on cellulose tissue to form open circular loops whose ends are close together. When one of these is exposed to a solution of a non-penetrating solute the gel shrinks, the loop opens and its ends separate proportionally. The gel can be made of concentration up to 70%, with negligible permeability to solutes of molecular weight 13000 or lower. A great increase in sensitivity over the Sephadex-bead method (in practice by a factor of up to 30) is achieved, in part by the greater contour length of the loop, in part by the 'bimetal' effect of differential shrinkage of its layers.

At the same time most of the advantages of the bead method (smallness of scale, shortness of equilibration time, simplicity and cheapness) are preserved.

Experimental

Materials

Acrylamide, NN'-methylenebisacrylamide and NNN'N'-tetramethylethylenediamine. These were B.D.H. laboratory reagents (BDH Chemicals Ltd., Poole, Dorset, U.K.), used without further purification.

Potassium persulphate. This was B.D.H. technical grade (BDH Chemicals Ltd.).

Dextran 500. This was from Pharmacia, Uppsala, Sweden (lot no. 5406).

Low-molecular-weight dextrans. These were gifts from Dr. K. Granath, Pharmacia, Uppsala, Sweden, who also supplied the values of number-average (Table 1) and weight-average molecular weights, determined by gel chromatography and by end-group analysis by the method of Park & Johnson (1949). The \bar{M}_w/\bar{M}_n values of the samples were in the range 1.1-1.3.

Polyethylene glycols 6000 and 1000. These were B.D.H. laboratory reagents (BDH Chemicals Ltd.).

Polyvinyl alcohol. This was the material used by Ogston & Wells (1970).

Human serum albumin. This was a sample prepared by Laurent & Öbrink (1972).

Ovalbumin. This was Sigma 'Albumin, Egg' grade V, lot no. 118B-8041 [Sigma (London) Chemical Co., London S.W.6, U.K.].

Cytochrome c. This was from Sigma (London) Chemical Co., from horse heart, type VI, lot no. 31C-7050.

Table 1. *Molecular weights of dextran samples*

For details see the text.

Dextran sample	$10^{-3} \times \bar{M}_w$	$10^{-3} \times \bar{M}_n$	\bar{M}_w/\bar{M}_n
52.8	77.5	52.8	1.47
37.5	50.5	37.5	1.35
19.7	26.5	19.7	1.35
13.4	14.7	13.4	1.10
7.1	8.46	7.08	1.19
6.6	7.33	6.58	1.11
4.5	5.05	4.52	1.12

A synthetic peptide. This was made by, and was a gift from, Dr. D. B. Hope, Department of Pharmacology, Oxford. Its molecular weight was 853.

A plus B chain of insulin. This was a gift from Dr. R. Cecil, Department of Biochemistry, Oxford, made by oxidation with performic acid.

Cellulose tissue. This was the wrapping from 'Cover glasses, 22mm × 25mm to British Standard 748' (Weber and Sons, Lancing, Sussex, U.K.). A single thickness of Kleenex tissue was a satisfactory substitute.

Solutions. These were made by weight in water or NaCl solutions; in calculating volume concentrations allowance was made for the moisture content and partial specific volumes of the solutes and the density of the solvents. Protein solutions were thoroughly dialysed against diffusate, changes of concentration during dialysis being measured spectrophotometrically.

Bilayer loops

Principle. Cross-linked polyacrylamide is cast, in an O₂-free atmosphere, into a mould so as to form a thin sheet of gel on a thin layer of cellulose tissue. This bilayer is removed from the mould and a narrow strip cut from it. When a strip is immersed in water or other aqueous solution, the gel swells a little but the cellulose tissue remains virtually unaffected, this differential swelling causing the strip to curl into a loop. By adjusting the contour length of the loop, the ends of the loops are made close together. The loop is mounted by a clip in a chamber on a microscope slide. The variation of the distance between the ends is measured with a micrometer eyepiece. The loop is calibrated with solutions of known osmotic pressure.

Making and using loops

Polymerization. Following the findings of Morris & Morris (1971), that polyacrylamide gel of a given total concentration has the lowest permeability when made

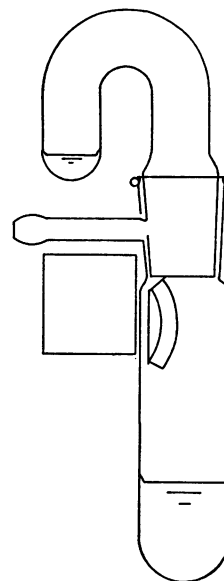
Fig. 1. *Use of a Thunberg tube for making loops under O₂-free conditions*

A re-curved mould (see Fig. 2b) is shown held in place by the magnet. The rubber band holding this magnet, that holding the parts of the mould together, and the piece of steel paper clip (see the text) are not shown.

with 5% of the cross-linking agent, this proportion was used throughout these studies. Mixed stock solutions in water of acrylamide and *NN'*-methylenebisacrylamide were made (19:1, by wt.) of such concentrations as to give the required final concentrations of gel. Stock solution (4.5 ml) was placed in a 20 ml Thunberg tube (Fig. 1) and 0.1 ml of *NNN'N'*-tetramethylethylenediamine (0.3 ml in 10 ml of water) was added. For gels up to and including 35% (w/v), 0.4 ml of 2% (w/v) K₂S₂O₈ in water, and for gels above 35% (w/v), 0.4 ml of 5% (w/v) K₂S₂O₈ in water, was placed in the curved stopper. The tube was then evacuated four or five times on a water pump, with admission of O₂-free N₂ after each evacuation. After the final evacuation, the contents of the vessel were mixed by inverting the tube, the mould (see below) was immersed in the solution and N₂ was admitted. Uniform gelation took place in 1–2 min after mixing. The tube was left standing in cold water for at least 2 h to allow complete polymerization.

Moulds. For gels of a concentration up to 35% (w/v) a plane mould was used (Fig. 2a). This consisted of two strips of haemocytometer cover-slip, each about 5 mm × 20 mm, cemented with Araldite on to

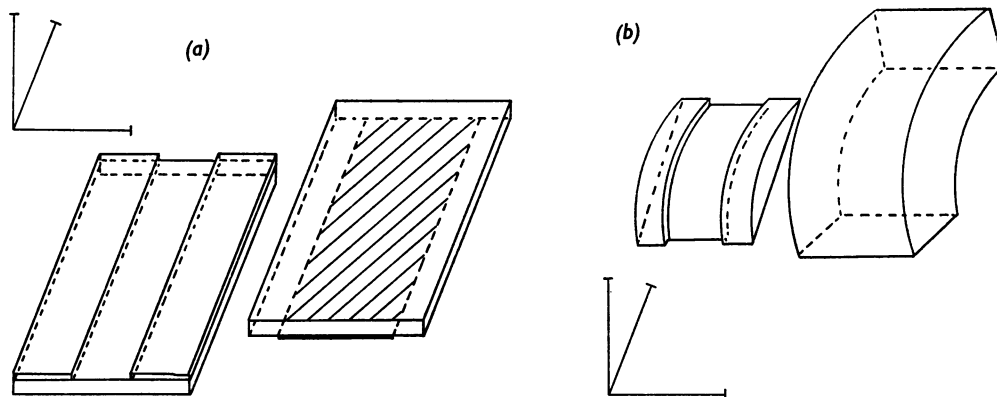

Fig. 2. Moulds for making bilayers

(a) Isometric diagram of a plane mould. The channel is on the left, the cover on the right. A piece of cellulose tissue (see the text) is shown applied to the under side of the cover. Scale distance = 1 cm. (b) Isometric diagram of a re-curved mould made of Perspex (see the text). The cellulose tissue, applied to the cover (right) as in Fig. 2(a), is not shown. Scale distance = 1 cm.

a piece of microscope slide, with their long edges parallel and 5 mm apart so as to form a channel about 5 mm \times 20 mm \times 0.5 mm deep. A cover for the channel 20 mm long and of sufficient width was cut from a microscope slide. A piece of thin cellulose tissue was cut to about the same size as the cover, care being taken that the main orientation of the cellulose fibres was parallel to the length of the channel. The tissue was applied to and stretched on the cover after it had been moistened with saliva. The cover, with tissue, was placed on the channel and held in place with a suitably distorted steel paper clip. The assembled mould formed an open-ended tube, 0.5 mm \times 5 mm \times 20 mm. It was held in the body of the Thunberg tube just below the grind by the use of a magnet attached externally to the side arm of the tube with a rubber band (Fig. 1). Immediately after the mixing of the contents of the tube (with care not to wet or splash the mould), and while it was still evacuated, the magnet was moved so as to lower the mould gently into the polymerizing mixture, which filled it. N_2 was then admitted to collapse any bubbles that might have clung to the cellulose.

Because strips made from gels more concentrated than 35% (w/v) curled into loops of inconveniently small radius, a mould with reversed curvature was used for these (Fig. 2b). A Perspex cylinder was made, 10 mm long \times 17 mm diameter, and a circumferential channel was machined on this, 5 mm wide \times 0.5 mm deep. A Perspex cylindrical annulus was made, 10 mm long \times 17 mm internal diameter \times 27 mm external diameter. Both cylinder and annulus were cut radially at 120° into three pieces; one piece of

each, with the tissue applied to the inner face of the annular part, formed the mould; they were held by a small rubber band, together with a piece of paper clip (so that the whole could be held by the magnet).

Loops. After gelation was complete, the excess of gel in the tube was broken up with a spatula, the mould was taken from the tube and adherent gel was removed. The cover was carefully lifted off. The tissue with its layer of gel could then be lifted out cleanly. It was moistened with water and placed, tissue side down, on a glass plate between two cover-slip spacers, 0.5 mm thick, cemented parallel and about 20 mm apart. Four or five strips, each about 20 mm long \times 1 mm wide, could then be cut, parallel to the long dimension (and to the cellulose fibres), with use, as a guide, of a smooth-edged microscope slide supported on the cover-slip spacers (Fig. 3a). To obtain clean cuts with Gillette stainless-steel razor blades, each corner of a blade was used twice only. The strips were then transferred to water or to the appropriate salt solution in a Petri dish and left for 1 h or more to equilibrate. A satisfactory loop is circular, free from bubbles, and the cellulose layer forms, or is everywhere close to, its inner surface.

Each such loop was next cut to a suitable contour length. The loop was placed on its side on a sheet of Perspex and encircling a small rectangular Perspex post cemented to the sheet (Fig. 3b). The loop was adjusted so that one of its ends projected past the post, against which it was gently gripped with a narrow piece of Perspex. The projecting end was cleanly trimmed off with a razor blade. Trimming was continued until the ends were 1–2 mm apart when the

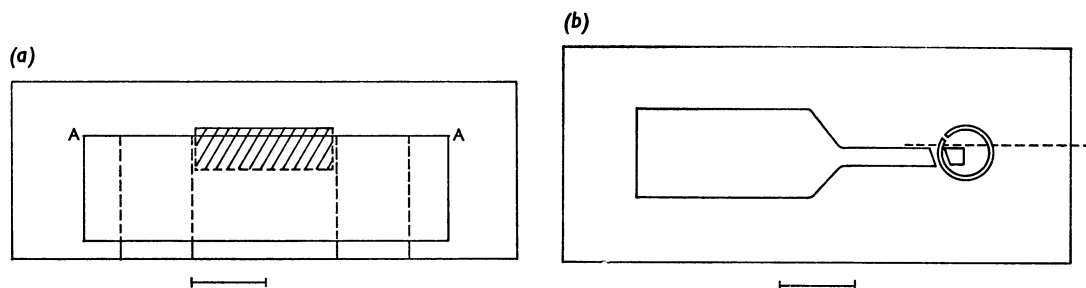

Fig. 3. *Jigs for trimming bilayer strips*

(a) Plan of jig for cutting strips (see the text). The gel bilayer is shown in place (■). The line of cut is marked A-A. Scale distance = 1 cm. (b) Plan of jig for trimming a loop to the required contour length (see the text). ---- shows the line of cut.

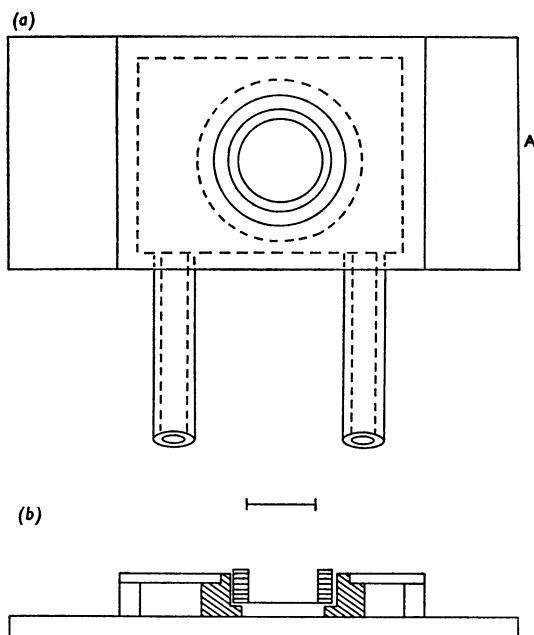

Fig. 4. *Slides for holding cells*

For details see the text. (a) Plan of the slide for holding the cell (for simplicity, a single-chamber slide is shown, and the cell is not included). (b) Section through the line A-A (see Fig. 4a), with the cell in place. ■ is brass, ▨ is stainless-steel and □ is Perspex. Scale distance = 1 cm.

loop was placed freely in solvent. The total contour length after trimming was 10–15 mm.

Mounting the loop. A slide (Fig. 4), through which thermostatically controlled water was circulated, was

made of Perspex and brass to fit on the mechanical stage of the microscope. It contained two circular brass chambers, 16 mm inner diameter \times 5 mm deep, into each of which a stainless-steel annular cell (16 mm external diameter \times 10 mm internal diameter \times 5 mm deep) was an easy fit; a circular cover-slip, cemented with Araldite to one end of the annulus, formed the base of the cell. A clip of platinum foil and wire (Fig. 5) was cemented with Araldite to a strip of glass (1 mm \times 2 mm \times 5 mm), which in turn was stuck with Picein cement on to the base of the cell. The midpoint of the loop was pushed gently into this clip and adjusted so that the loop lay horizontally. The upper end of the cell was closed by a circular cover-slip.

Filling and replacement of solutions. Solvent or solution was added to the cell by means of a teat pipette or a small syringe so as just to fill the cell. The cover-slip was then slid into place. Small air bubbles not in contact with the loop did not interfere. The cell was emptied similarly. Although emptying in this way left not more than 2% of the previous solution in the cell, an intermediate washing with fresh solution was used when there was no shortage of material. Solutions were adjusted to 25°C before use.

Measurement. The microscope was a Carl Zeiss (Jena) NfpK Research microscope fitted with a two-way mechanical stage. The objective was a Zeiss \times 2.5 Planachromat, used with a 'spectacle lens' condenser. The ocular was a Vickers \times 10 Kellner micrometer. The magnification at the ocular cross-wire was \times 5. The stage was adjusted so that both ends of the loop were in view. A sharply defined and recognizable feature in each loop end was chosen. The ocular was rotated so as to allow the nearest distance between these to be measured, with slight refocusing for each chosen feature if necessary. The micrometer scale could be read to $\pm 1 \mu\text{m}$, corresponding to

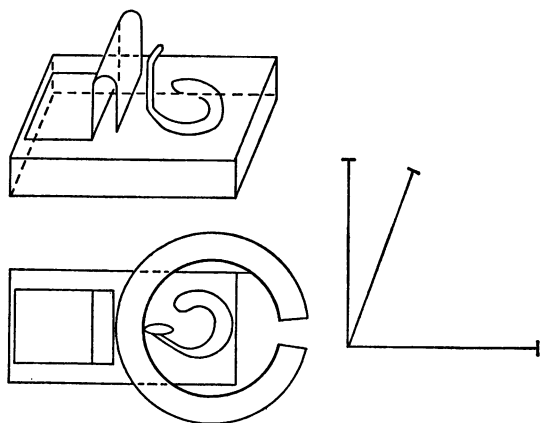

Fig. 5. Isometric drawing and plan (with loop shown in place) of the clip for the loop

The clip is made of platinum foil and wire, cemented to glass (see the text). Scale distance = 5 mm.

$\pm 0.2 \mu\text{m}$ at the object. At least three (usually more) independent measurements of each distance were made.

Temperature control. Water was circulated to the slide through short lagged tubes from an external thermostat maintained at $25 \pm 0.05^\circ\text{C}$.

Calibration. Solutions of Dextran 52.8 made by weight in water or salt solution were used for calibration. Their osmotic pressures were calculated from the virial coefficients determined by Edmond *et al.* (1968), quoted by Ogston & Wells (1970), by eqn. (1):

$$\frac{\pi}{RT} = \frac{c}{M} + A_2 c^2 + A_3 c^3 \quad (1)$$

where c is the concentration (g/ml), $A_2 = 0.51 \times 10^{-3} \text{ mol} \cdot \text{cm}^3 \cdot \text{g}^{-2}$, $A_3 = 2.0 \times 10^{-3} \text{ mol} \cdot \text{cm}^6 \cdot \text{g}^{-3}$, $M = 5.28 \times 10^4 \text{ g/mol}$; π/RT is mosm.

Results

Quantities

All dimensions quoted are those of the unmagnified object. Gel concentrations are % (w/v) as cast; that is, no allowance is made for the slight swelling that takes place on immersion in solvent.

Gel permeability

Preliminary experiments were made with cylinders of 18% gel cast as described, but in short lengths of Pyrex 1 mm precision-bore tubing, their diameters being measured by the photographic method of Ogston & Wells (1970). Solutions of Dextran 500 and of Dextran 52.8 gave precisely the same diameter-

osmotic-pressure relationships, showing that this gel is effectively impermeable to Dextran 52.8, which is therefore a suitable calibrating substance. Dextran 37.5 gave slightly but significantly smaller changes of diameter at corresponding osmotic pressures.

Temperature

The increased sensitivity of the loops revealed that the temperature must be controlled to within $\pm 0.05^\circ\text{C}$.

Effect of salt

An approximately linear dependence was found between the loop end separation and the concentration of NaCl in water. This was such that the concentration of supporting salt must be kept constant within 0.1 mm both in calibration and in measurement if the full precision of the method is to be exploited. This is best achieved by thorough dialysis of experimental solutions and use of equilibrium diffusate as the solvent for calibration.

Precision

Repeated measurements made on the same loop in the same solution on a number of occasions (114 independent measurements in 21 sets) gave the standard error of a single measurement as $0.8 \mu\text{m}$.

Reproducibility

In each calibration (with Dextran 52.8), and in most osmotic measurements, three or more different solutions were used, of osmotic pressure up to that of a 1 mosm solution, in addition to solvent. The measurement on solvent was always repeated after those on the solutions; sometimes measurements were repeated on one or more of the solutions. For each measurement three or more independent readings were made. The mean maximum divergence within 18 such pairs or sets of measurements (52 measurements in all, each the mean on average of four readings) was $0.9 \mu\text{m}$. Calibration curves were linear within the range of osmotic pressure; most experimental curves (loop measurement against concentration) were also linear. The least-squares fit of seven such sets of linear results obtained with 25–50% gels gave coefficients of variation of the estimated slopes of 0.001–0.041, mean 0.008. The estimated residual root-mean-square deviations of individual readings from the fitted lines were usually 1–1.5 μm , occasionally as high as 4 μm , showing a high degree of linearity.

Sensitivity

By this we mean the change of osmotic pressure corresponding to the least significantly detectable change of separation of the ends of the loop. It is an

unsatisfactory term because the higher the sensitivity the smaller the number that expresses it, but we have not been able to find a better. If we assume that at least four individual measurements are made of each distance, the s.e.m. will be not greater than $0.5\mu\text{m}$. This quantity divided by the slope of the calibration curve (end separation against osmotic pressure) gives the values shown in Table 2. The values vary approximately linearly with gel concentration. Variation between different loops of the same gel concentration arises principally from differences of their contour lengths.

Rate of equilibration

The time-course of change of end separation, after a change of solution, was followed on a number of occasions. The process was first order with velocity constants 0.15min^{-1} (solvent to solution) and 0.20min^{-1} (solution to solvent) respectively. The difference was consistent, but unexplained. Rates varied little with gel concentration. Usually the total changes are such that they are complete within the error of measurement in 20–30min.

Test measurements

These are summarized in Table 3. The estimated standard errors are based on those of the ratios of slope of the calibration curve (end separation against osmotic pressure) to the slope of the experimental curve (end separation against concentration). The

Table 2. Sensitivities of loops made with various concentrations of polyacrylamide gel

For experimental details see the text.

Gel concentration (%, w/v)	Sensitivity (Pa)
25	3.2
25	7.5
30	18.1
35	18.2
40	17.5
50	28.5
60	40.5
70	50.7

Table 3. Examples of molecular weights determined by the polyacrylamide-gel-loop method

For experimental details see the text.

Solutes	Gel concn. (%, w/v)	$10^3 \times$ Highest concn. of solute (g/ml)	No. of solutions	No. of measurements	Estimate of number-average mol.wt. (\pm s.e.m.)
Human serum albumin	35	30.0	5	34	66000 (700)*
Ovalbumin	25	15.8	5	29	44380 (600)†
Cytochrome c	35	4.5	3	29	12580 (160)‡
	50	5.0	4	31	12320 (170)‡
Dextran 19.7	30	9	4	33	19500 (340)
Dextran 13.4	35	7.1	4	32	13100 (170)§
Dextran 7.1	35	2.6	2	18	7600 (160)§
	40	2.6	3	27	7270 (150)§
Dextran 6.6	60	3.04	1	8	6610 (130)§
Dextran 4.5	60	3.31	1	10	4700 (110)§
Polyvinyl alcohol	30	19	4	41	46000 (600)
Polyethylene glycol 6000	30	4.8	3	16	5820 (130)
	30	4.8	5	48	5530 (100)
	30	4.8	4	18	5530 (100)
	40	3.6	4	24	5582 (65)
	35	0.58	1	16	1500 (45)
Polyethylene glycol 1000	40	1.47	3	26	1695 (17)
	50	1.47	4	34	1464 (20)
	60	1.47	3	32	1566 (32)
	70	1.47	3	35	1525 (50)

* Creeth (1952) obtained 65360; Low (1952) obtained 65600.

† Warner (1954) accepted 45000.

‡ Formula value is 12384.

§ See Table 1.

|| B. N. Preston (unpublished work) obtained $M_n = 46000$ (6000) for this material by membrane osmometry.

linear least-squares fit of the results was used except for Dextran 19.7 and polyvinyl alcohol; in these cases a term in the square of the concentration was included. It should be noted that the polyethylene glycol 6000 was not the same material as was used by Nichol *et al.* (1967), Edmond & Ogston (1968) and Ogston & Silpananta (1970).

In addition to the measurements given in Table 3, attempts were made to measure molecular weights of dextran fractions of molecular weight less than 3000, of mixed A plus B chain of insulin, and of a synthetic peptide. In all these cases there was evidence of excessive penetration of 60 or 70% gel; 'rebound' (Ogston & Wells, 1970) was observed on changing from solution to buffer or the reverse, and high estimates of the molecular weight were obtained.

Discussion

Sensitivity of the method

For illustration, we compare a loop with a bead of the same gel of 0.5 mm diameter (Ogston & Wells, 1970). Typically the length of gel in the loop is 15 mm, so that a 30-fold gain is obtained from this alone. Further, if a loop forms a just complete circle of contour length L , x is the separation of the ends, and the effective radial separation of gel and cellulose layer is δ , then:

$$\frac{dx}{dL} = \frac{L\delta}{2\pi}$$

so that if we take δ as one-half the thickness of the gel, i.e. 0.25 mm, then $dx/dL = 9.6$. The whole increase of sensitivity is therefore by a factor $9.6 \times 30 = 288$. In a preliminary experiment a 1 mm-diam. cylinder of 18% (w/v) polyacrylamide gave a diameter change of $-44 \mu\text{m}/\text{mosmol}$ with solutions of Dextran 500 and a 15 mm-diam. loop gave a change of end separation of 63 mm/mosmol. On this basis, the loop was $2 \times 6.3/44 \times 10^{-3} = 286$ times more sensitive than a 0.5 mm cylinder, in excellent agreement with prediction.

In practice we have not achieved so great a factor (Table 2), mainly because of the lower precision of measurement with a micrometer eyepiece compared with that of the photographic method of Ogston & Wells (1970). We have not sought further improvement in this respect, partly because of the speed and convenience of direct visual measurement, partly because of the difficulty of finding suitable features in the ends of the loop that will remain simultaneously in the absolutely sharp focus which the photographic method requires.

Molecular size of solute and penetration of the gel

If the solute penetrates the gel to a significant extent, the internal osmotic pressure of the gel phase

will be increased by an amount due to the internal equilibrium concentration of the solute (c_2'/M_2) plus a term $A^*c_1'c_2'$ (Ogston & Silpananta, 1970; writing c_1' in place of c_2'), where c_2' is the internal concentration of solute, M_2 is its molecular weight, c_1' is the concentration of the gel and A^* is the interaction coefficient between solute and gel. The observed osmotic pressure will therefore be decreased by the sum of these terms, the relative error being:

$$-\left(\frac{c_2'}{M_2} + A^*c_1'c_2'\right) \bigg/ \frac{c_2''}{M_2} \equiv -K_{AV}(1 + A^*M_2c_1') \quad (2)$$

where c_2'' is the concentration of solute in the solution and K_{AV} is c_2'/c_2'' . From eqn. (5) of Ogston & Silpananta (1970) (the last term of which should be $-A^*c_2'$), neglecting self-interaction terms and the small pressure term \bar{v}_2Pf , and noting that A^*M_2 equals ϵ (the limiting exclusion volume per g of dry gel), the relative error can be written:

$$e^{-\epsilon c_1'(1 + \epsilon c_1')} \quad (3)$$

If this is not to exceed -0.01 , then c_1' must not be less than 6.6.

If we assume the gel to consist of cylindrical molecular fibres, of radius r_t and length l per g of dry gel, and assume the solute molecules to be spheres of radius r_s , then:

$$\epsilon = \pi(r_s + r_t)^2 l \quad (4)$$

and

$$\bar{v}_t = \pi r_t^2 l \quad (5)$$

where \bar{v}_t is the partial specific volume of gel. Combining these:

$$r_s = r_t \left[\left(\frac{\epsilon}{\bar{v}_t} \right)^{\frac{1}{2}} - 1 \right] \quad (6)$$

so that the limiting value of r_s [$(r_s)_{lim.}$] is given by:

$$(r_s)_{lim.} = r_t \left[\left(\frac{6.6}{c_1' \bar{v}_t} \right)^{\frac{1}{2}} - 1 \right] \quad (7)$$

Taking r_t for polyacrylamide as 0.5 nm and $\bar{v}_t = 0.7$ (A. G. Ogston, B. N. Preston & J. D. Wells, unpublished work) gives the values for $(r_s)_{lim.}$ shown in Table 4. These values appear to overestimate the lower limit of effective radius. Thus cytochrome c , if an unsolvated sphere, would have a radius of 1.6 nm but did not penetrate a 35% gel significantly. It must further be remembered that r_s is the effective radius of the solute molecule, which will be greater for a given molecular weight if the molecule has a non-compact structure. For example, it would be expected that polyethylene glycol 1000 would have an effective radius of 1.5 nm, based on the dimensions of polyethylene glycol 6000 given by Ogston & Silpananta (1970) as 3.0 nm. It is observed that the polyethylene glycol 1000 is also sufficiently excluded

Table 4. Lower limiting values of the effective radius (r_s) of solute molecules required to make the error in osmotic pressures due to penetration of the gel not greater than 0.01 (see the text, eqn. 7), with corresponding molecular weights (M) of compact spherical molecules of $\bar{v} = 0.75$

For further details see the text.

Gel concentration			
(%, w/v)	(g/ml) (c_f)	(r_s) _{lim.} (nm)	$10^{-3} M$
20	0.2	2.9	29
30	0.3	2.3	16
40	0.4	1.9	11
50	0.5	1.7	7.4
60	0.6	1.5	5.8
70	0.7	1.3	4.5

by a 35% gel. Nevertheless, Table 4 provides some guide to the molecular sizes of solutes for which this method is suitable.

General aspects

The method described represents a marked improvement on the Sephadex-bead method (Ogston & Wells, 1970) in two respects: (i) it is very much more sensitive, sufficiently so to allow accurate estimates of molecular weight to be made from osmotic pressures of relatively dilute solutions; (ii) the use of polyacrylamide, together with the increased sensitivity, allows measurements to be made on solutes of much lower molecular size. Its main disadvantages are: (i) it requires about ten times as much solution per measurement; this is offset, however, by the fact that more dilute solutions can be used (an accurate measurement can be made, for example, with 1 mg of solute or less); (ii) the equilibration time, though still conveniently short, is somewhat longer (20–30 min as compared with 10 min); this is offset by the speed of visual in place of photographic measurement; (iii) the increased sensitivity requires

precise control of temperature and of the concentration of the buffer salts.

The useful range of the method as described is up to 5 kPa (2 mosm); for osmotic pressures above this the bead method (or a modification of it) is sufficiently accurate. The method compares well with membrane osmometry in its combination of range, accuracy, smallness of scale, speed, simplicity and cheapness; it is, of course, not an absolute method but requires calibration. It should be possible to modify it for use with non-aqueous systems.

We are grateful to Professor R. R. Porter and the University of Oxford for facilities in the Department of Biochemistry, to Professor T. C. Laurent and to the University of Uppsala for facilities in the Institute of Medical Chemistry, to the Medical Research Council for a grant from which the microscopic equipment was purchased, to Dr. K. Granath for the samples of dextran, to Professor Laurent for the human serum albumin, to Dr. R. Cecil for the preparation of insulin chains, and to Dr. D. B. Hope for the synthetic peptide. B. N. P. was on sabbatical leave from the Department of Biochemistry, Monash University, Clayton, Victoria, Australia. We acknowledge helpful discussion and suggestions from Dr. J. D. Wells: most especially we acknowledge the suggestion of Dr. C. W. McCutchen which initiated this work.

References

- Creeth, J. M. (1952) *Biochem. J.* **51**, 10–17
 Edmond, E. & Ogston, A. G. (1968) *Biochem. J.* **109**, 569–576
 Edmond, E., Farquhar, S., Dunstone, J. R. & Ogston, A. G. (1968) *Biochem. J.* **108**, 755–763
 Laurent, T. C. & Öbrink, B. (1972) *Eur. J. Biochem.* **28**, 94–101
 Low, B. W. (1952) *J. Amer. Chem. Soc.* **74**, 4830–4834
 Morris, C. J. O. R. & Morris, P. (1971) *Biochem. J.* **124**, 517–528
 Nichol, L. W., Ogston, A. G. & Preston, B. N. (1967) *Biochem. J.* **102**, 407–416
 Ogston, A. G. & Silpananta, P. (1970) *Biochem. J.* **116**, 171–175
 Ogston, A. G. & Wells, J. D. (1970) *Biochem. J.* **119**, 67–73
 Park, J. T. & Johnson, M. J. (1949) *J. Biol. Chem.* **181**, 149–151
 Warner, R. C. (1954) *Proteins*, 1st edn., 2, part A, pp. 448, 449