

EVIDENCE FOR TWO TRANSIENT SODIUM CURRENTS IN THE FROG NODE OF RANVIER

BY EVELYNE BENOIT, ALAIN CORBIER AND JEAN-MARC DUBOIS*

From the Laboratoire de Physiologie Comparée, Université Paris XI and Laboratoire de Physiologie Cellulaire et des Ensembles Neuronaux associé au CNRS, 91405-Orsay, France

(Received 26 June 1984)

SUMMARY

1. Na current (I_{Na}) was monitored in isolated voltage-clamped frog nodes of Ranvier in order to analyse the pharmacological and kinetic properties of fast and slow phases of inactivation.

2. Niflumic acid (0.1–10 mM) and tetrodotoxin (0.3–30 nM) did not alter fast and slow inactivation time courses but preferentially reduced the amplitude of the fast phase of inactivation. The block of both phases of inactivation by niflumic acid and tetrodotoxin was well described if one assumed that more than one molecule of drug reacted with one channel.

3. Fast and slow currents, corresponding respectively to fast and slow phases of inactivation, reversed at different potentials, had different threshold voltages of activation and the slopes of their steady-state inactivation curves were different. The recovery from inactivation of the compound I_{Na} could be described by the sum of two exponentials (plus a delay) corresponding respectively to fast and slow currents.

4. When calculated from I_{Na} recorded without and with niflumic acid or tetrodotoxin, the slow current activated about three times more slowly than the fast current.

5. Large prehyperpolarizations delayed both the activation and the inactivation of the fast current but only the activation of the slow current.

6. Lowering the temperature decreased the fast current but increased the slow current.

7. We conclude that the inactivatable Na current of the nodal membrane is made up of two components ($I_{Na,f}$ and $I_{Na,s}$) corresponding to two different and interconvertible forms of the Na channel.

INTRODUCTION

In the node of Ranvier, the time course of the Na current inactivation cannot be described by a single exponential but is well fitted by the sum of two exponentials. This has been interpreted as resulting from the existence of several inactivated or several open states of the channels (Chiu, 1977; Nonner, 1980; Ochs, Bromm &

* To whom reprint requests should be addressed at Laboratoire de Physiologie Comparée, Bât. 443, Université Paris XI, 91405-Orsay, France.

Schwarz, 1981; Sigworth, 1981; Neumcke & Stämpfli, 1982). Alternatively, one can assume that the two phases of Na inactivation correspond to two distinct currents flowing through two different types of Na channels. We present several pharmacological and kinetic arguments supporting this hypothesis and describe some properties of the two presumed types of Na channels. A preliminary report of part of the results has been given (Corbier & Dubois, 1983).

METHODS

The experiments were carried out on nodes of Ranvier of isolated myelinated nerve fibres from the frog *Rana esculenta*. The nodal membrane was voltage clamped using the method of Nonner (1969). Membrane currents were calculated arbitrarily assuming an axoplasmic resistance of 10 M Ω . A membrane potential of -70 mV was defined as the potential corresponding to 30% inactivation of the peak Na current recorded at 0 mV. If not stated otherwise, the node was maintained at a holding potential of -70 mV. Resting Na inactivation was removed by 50 ms pre-pulses to -110, -120 or -160 mV. Linear leakage and capacity currents were subtracted electronically from the total current.

The node was superfused with control Ringer solution or test solutions. The Ringer solution had the following composition (mM): NaCl, 111.5; KCl, 2.5; CaCl₂, 1.8; NaHCO₃, 2.4; pH, 7.4. A 1 M-solution of niflumic acid (NA) in NaOH was diluted in Ringer solution to give final niflumic acid concentrations. The pH was adjusted with HCl. Ionic currents through K channels were suppressed by replacing the end-pool solution with CsCl (120 mM) and adding tetraethylammonium (10 mM) to the external solution.

The temperature was measured with a small thermistor placed in the cooled block which held the chamber. Temperature changes were carried out more slowly than 0.5 °C min⁻¹ in order to avoid time-dependent processes caused by slow relaxation of the gating kinetics (Schwarz, 1979).

Na currents were recorded after low-pass filtering with an active Bessel filter with cut-off frequency set at 10 or 20 kHz. The inactivation time course of Na current (I_{Na}) was described by the equation:

$$I_{Na} = I_{Na, f_0} e^{-t/\tau_{h, f}} + I_{Na, s_0} e^{-t/\tau_{h, s}} + I_1, \quad (1)$$

where I_{Na, f_0} and I_{Na, s_0} were the extrapolated values to time zero of the fast and slow phases of inactivation, $\tau_{h, f}$ and $\tau_{h, s}$ were the fast and slow inactivation time constants and I_1 was either a non-inactivating Na current (late Na current) (Dubois & Bergman, 1975) or a non-linear leakage current. I_1 , assumed to be time independent, represented less than 3% of the peak Na current. It was measured at the end of 20–50 ms depolarizations and was subtracted from the total current.

The values of initial amplitudes and time constants were determined either by eye or by linear-regression analyses ($r^2 \geq 0.98$) using logarithms of the measured values. No systematic and important differences were noted between the values obtained by the two methods. However, it must be noted that the values of initial amplitudes (I_{Na, f_0} and I_{Na, s_0}) are very sensitive to inaccuracies in determinations of I_1 and of the time corresponding to the full inactivation of $I_{Na, f}$. Because of these inaccuracies, we estimate that I_{Na, f_0} and I_{Na, s_0} were determined with a maximum error of 5%.

The effective series resistance was uncompensated. In the frog node of Ranvier, the series resistance was considered to be either relatively important (Drouin & Neumcke, 1974; Sigworth, 1980; Neumcke & Stämpfli, 1983) or negligible (Chiu, 1977; Kniffki, Siemen & Vogel, 1981). We made control experiments to test these assumptions in our experimental conditions. The usual method of compensation of the series resistance is positive feed-back, and full compensation is assumed to be achieved when, at a given depolarizing voltage, the time course of I_{Na} is independent of the amplitude of the current. In the experiments presented in Fig. 1, the amplitude of the peak current was reduced to about 35% of its control value by lowering the external Na concentration to 30 mM, or adding tetrodotoxin (TTX) (4 nM) to the external solution or applying a 50 ms prepolarization to -61 mV (instead of a prehyperpolarization to -120 mV). In these experimental conditions the inactivation time constants ($\tau_{h, f}$ and $\tau_{h, s}$) were not significantly different. With TTX and prepolarization, the inactivation time course of the over-all current was modified, due to

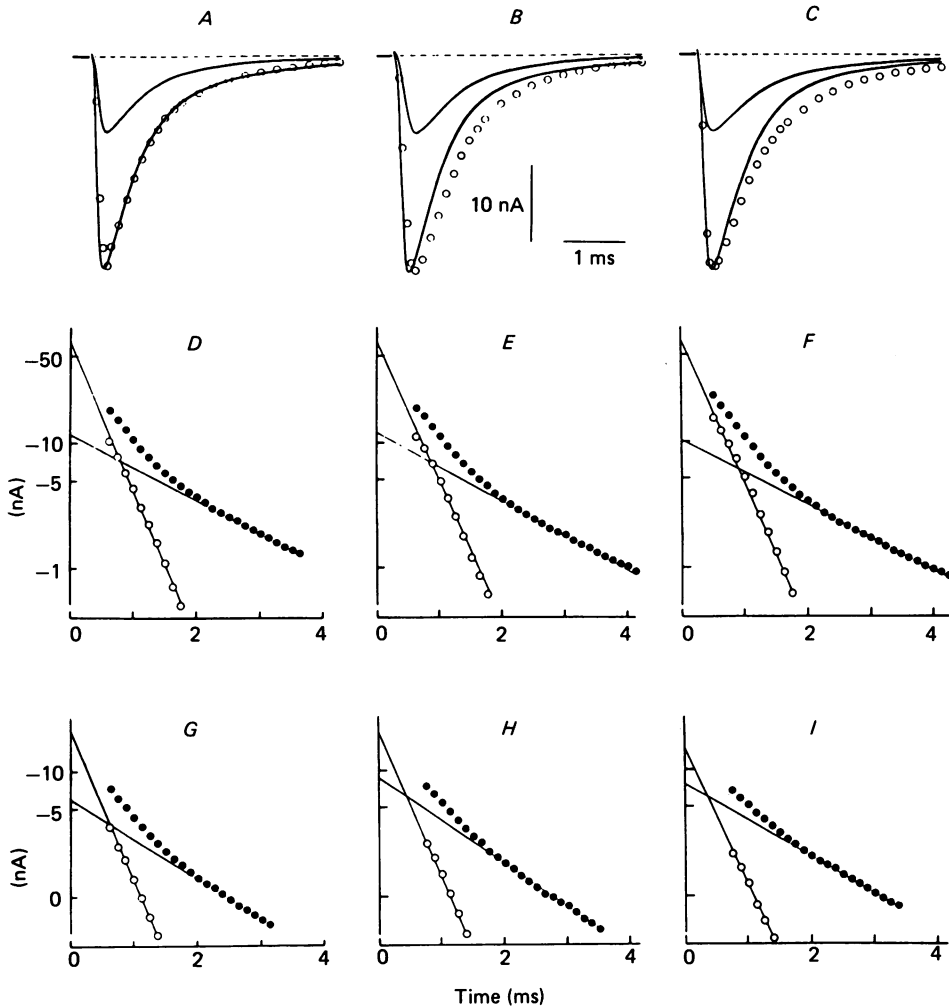

Fig. 1. Effects of decreasing the amplitude of the Na current on its time course of inactivation. *A-C*, superimposed traces of Na current recorded during depolarizations to -10 mV in control and in low-Na solution (30 mM-NaCl + 90 mM-CsCl) (*A*), in control and in the presence of 4 nM-TTX (*B*) and with a 50 ms pre-pulse to either -120 or -61 mV (*C*). The circles were obtained by multiplying the values of the reduced currents by 2.6 (*A*) and 2.8 (*B* and *C*). *D-I*, representations in semilogarithmic coordinates of the inactivation phases of I_{Na} traces presented in *A-C*, in control conditions (*D-F*), in low-Na solution (*G*), in the presence of TTX (*H*) and with the pre-pulse to -61 mV (*I*). $\tau_{h,t}$ is 0.37 ms (*D*), 0.38 ms (*E*), 0.38 ms (*F*), 0.36 ms (*G*), 0.37 ms (*H*) and 0.39 ms (*I*). $\tau_{h,s}$ is 1.63 ms (*D*), 1.54 ms (*E*), 1.68 ms (*F*), 1.35 ms (*G*), 1.24 ms (*H*) and 1.48 ms (*I*). $I_{\text{Na},s0}/I_{\text{Na},f0}$ is, in the control: 0.19 (*D*), 0.18 (*E*), 0.16 (*F*); in low-Na solution: 0.28 (*G*); with TTX: 0.43 (*H*) and with the predepolarization: 0.51 (*I*). Temperature: 13.5°C . Fibre: 22-05-84.

a more important reduction of I_{Na, f_0} than I_{Na, s_0} . Moreover, one can note that the time to peak of I_{Na} was not significantly modified in low-Na solution and with the prepolarization (Fig. 1A and C) but was increased with TTX (Fig. 1B; see also Chiu, 1977, Fig. 8 and Neumcke & Stämpfli, 1983). In the experiment presented in Fig. 1, the ratio of reductions of I_{Na, f_0} and I_{Na, s_0} was 0.42 with TTX and 0.30 with the prepolarization. In four identical experiments, this ratio was 0.72 ± 0.02 in low-Na solution. If one assumes that the value of the series resistance is not modified by TTX or the low-Na solution, these results indicate that at least a part of the change in the time course of the over-all current with the reduction of its amplitude is not due to the series resistance, but should result from different properties of the two phases of inactivation. The effects of TTX and prepolarization are analysed in the Results section. The differential effects of the low-Na solution on I_{Na, f_0} and I_{Na, s_0} can be due either to the series resistance or to different sensitivities of the two phases of Na inactivation to the external Na concentration. In order to test these possibilities, we recorded the Na current in high- and low-Na solutions either with a holding potential (V_h) set at -70 mV or after reduction of the current via the 'ultra slow' inactivation (Fox, 1976) to about 50% of its control value with V_h set at -50 mV. In both cases, the test pulse was preceded by a 50 ms pre-pulse to -120 mV. Under both conditions, we found that in low-Na solution, I_{Na, f_0} was more reduced than I_{Na, s_0} . The ratio of reductions of I_{Na, f_0} and I_{Na, s_0} was 0.68 with $V_h = -70$ mV and 0.73 with $V_h = -50$ mV. This clearly indicates that in our experimental conditions, the series resistance can be considered as negligible.

Recently, it has been shown (Dubois & Coulombe, 1984) that, in the node of Ranvier, an inward Na current could induce a depletion of Na ions in the perinodal space and consequently a change in Na driving force and Na conductance. However, in normal fibres, these effects can be, in a first approximation, considered as negligible. Our results, by showing that at a given voltage, $\tau_{h, f}$ and $\tau_{h, s}$ are independent of the current amplitude, prove the validity of this approximation.

The experiments were carried out indiscriminately on motor or sensory fibres. In contrast with Schwarz, Bromm, Speilman & Weytjens (1983), we did not observe any qualitative differences between the two types of fibres. However, this point would have to be clarified by further experiments, concerning especially the relative amplitudes of fast and slow phases of Na inactivation in the two types of fibres.

RESULTS

Separation of fast and slow Na currents by niflumic acid

The best way to demonstrate that the two phases of an ionic current correspond to two different components is to use a drug which blocks one phase without affecting the other. We found that niflumic acid was an efficient tool for separating two Na currents in the frog node of Ranvier. Niflumic acid is an anti-inflammatory drug. It blocks the chloride permeability in red blood cells (Cousin & Motais, 1979) and in crayfish muscle fibres (Brûlé, Haudecoeur, Jdâiaa & Guilbault, 1983) in the 10^{-9} – 10^{-6} M concentration range. In the node of Ranvier, we observed that external niflumic acid had no effect on the ionic permeabilities for concentrations up to 0.1 mM. For larger concentrations, it reversibly and rapidly blocked I_{Na} and shifted the steady-state Na inactivation curve towards negative voltages. Moreover, we observed that niflumic acid exerted differential effects on the two phases of Na current inactivation.

Fig. 2 presents traces of Na current and representations in semilogarithmic coordinates of their inactivation phases in the absence and in the presence of 2 and 5 mM-external niflumic acid. In each solution, the Na current was recorded during depolarizations to 0 mV preceded by 50 ms hyperpolarizations to -160 mV. Niflumic acid did not significantly modify the inactivation time constants (see also Table 1) but preferentially reduced the amplitude of the fast inactivation phase. With

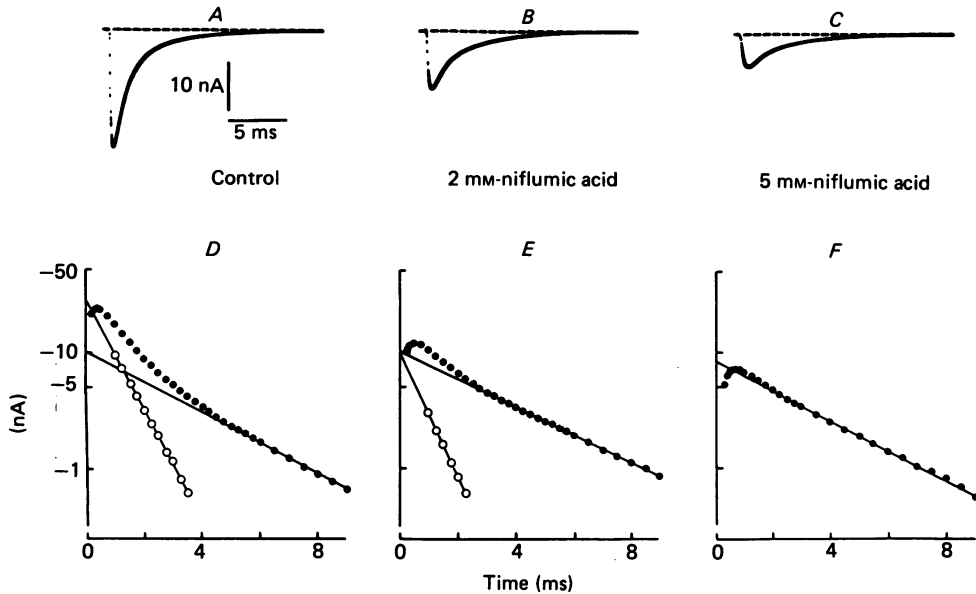

Fig. 2. Separation of fast and slow currents by niflumic acid. Traces of Na current (upper) and representations in semilogarithmic coordinates of their inactivation phases (lower) without (*A* and *D*) and with 2 mM- (*B* and *E*) and 5 mM- (*C* and *F*) niflumic acid. The current was recorded during depolarizations to 0 mV preceded by 50 ms hyperpolarizations to -160 mV. In *D*, *E* and *F*, filled circles give the over-all Na current and open circles give the fast current after subtraction of the slow current (straight line through filled circles). $\tau_{h,f}$ is 0.87 ms (control) and 0.79 ms (2 mM-niflumic acid). $\tau_{h,s}$ is 3.17 ms (control), 3.64 ms (2 mM-niflumic acid) and 3.48 ms (5 mM-niflumic acid). $I_{\text{Na},s_0}/I_{\text{Na},f_0}$ is 0.37 (*D*) and 0.95 (*E*). Temperature: 10 °C. Fibre: 17-02-83.

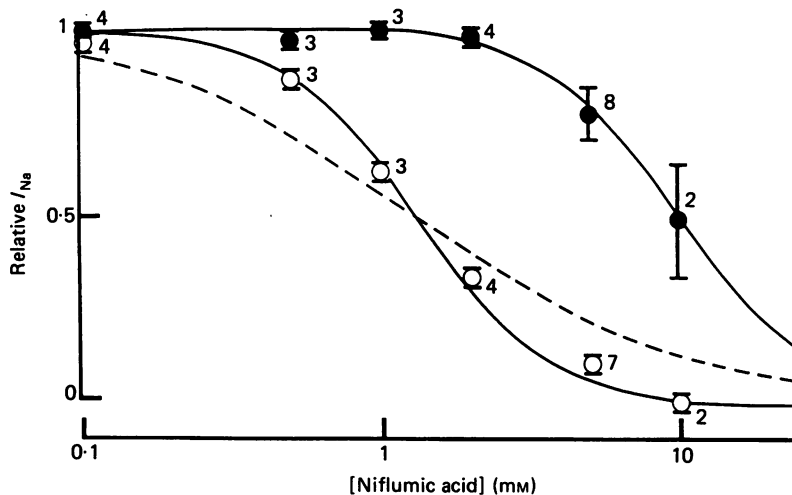

Fig. 3. Niflumic acid dose-response curves for fast and slow currents. Fast (open circles) and slow (filled circles) currents are extrapolated values to time zero of fast and slow phases of inactivation. The currents were normalized to their respective values in the absence of niflumic acid. Mean values and s.e. of mean obtained in two to eight experiments. The numbers besides each point give the number of experiments. The dashed curve represents the inhibition of the fast current assuming a one-to-one reaction between channels and niflumic acid molecules, with a dissociation constant of 1.3 mM. The continuous curves were calculated from eqn. (2) with $K = 1.3$ mM (fast current) and 10 mM (slow current). Temperature: 10–13 °C.

5 mM-niflumic acid, the fast inactivation phase was almost completely blocked whereas the slow inactivation phase was only slightly reduced. Moreover, it must be noted that niflumic acid significantly increased the time to peak of I_{Na} .

Fig. 3 represents dose-response curves of the effects of niflumic acid on the fast ($I_{Na,f}$) and slow ($I_{Na,s}$) phases of inactivation. The points are mean values of $I_{Na,f}$ and $I_{Na,s}$.

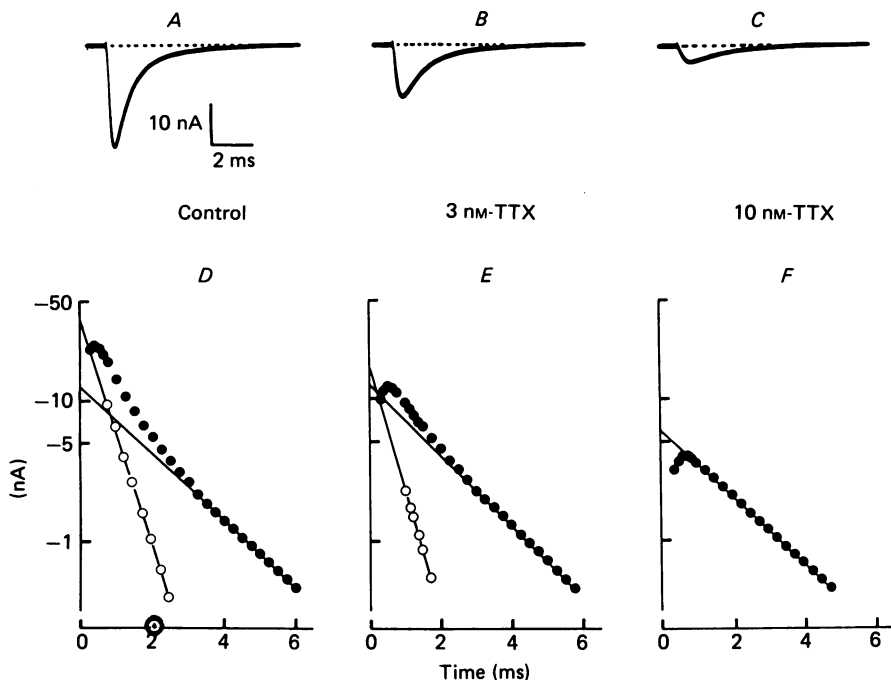

Fig. 4. Separation of fast and slow currents by TTX. Traces of Na current (upper) and representations in semilogarithmic coordinates of their inactivation phases (lower) without (*A* and *D*) and with 3 nM- (*B* and *E*) and 10 nM- (*C* and *F*) TTX. The current was recorded during depolarizations to 0 mV preceded by 50 ms hyperpolarizations to -120 mV. In *D*, *E* and *F*, filled circles give the over-all current and open circles give the fast current after subtracting the slow current (straight line through filled circles). $\tau_{h,f}$ is 0.58 ms (control) and 0.55 ms (3 nM-TTX). $\tau_{h,s}$ is 1.83 ms (control), 1.74 ms (3 nM-TTX) and 1.80 ms (10 nM-TTX). $I_{Na,s_0}/I_{Na,f_0}$ is 0.34 (*D*) and 0.93 (*E*). Temperature: 14 °C. Fibre: 23-09-83.

and I_{Na,s_0} obtained on different fibres and normalized to their respective values in control solution. It is clear from Fig. 3 that niflumic acid had differential effects on $I_{Na,f}$ and $I_{Na,s}$. Moreover, the block of $I_{Na,f}$ and $I_{Na,s}$ cannot be described assuming a one-to-one reaction between channels and niflumic acid molecules (dashed curve in Fig. 3). In contrast, it is well fitted by eqn. (2) which suggests that two molecules of niflumic acid are necessary to block one channel:

$$\frac{I}{I_0} = 1 - \frac{1}{1 + \frac{K^2}{[D]^2}}, \quad (2)$$

where I and I_0 are the currents without and with drug (D) respectively, and K is the concentration of drug corresponding to a 50% block of the current.

Separation of fast and slow Na currents by TTX

The preceding results suggest the existence, in the nodal membrane, of two types of Na channels with different affinities for niflumic acid. Following this conclusion,

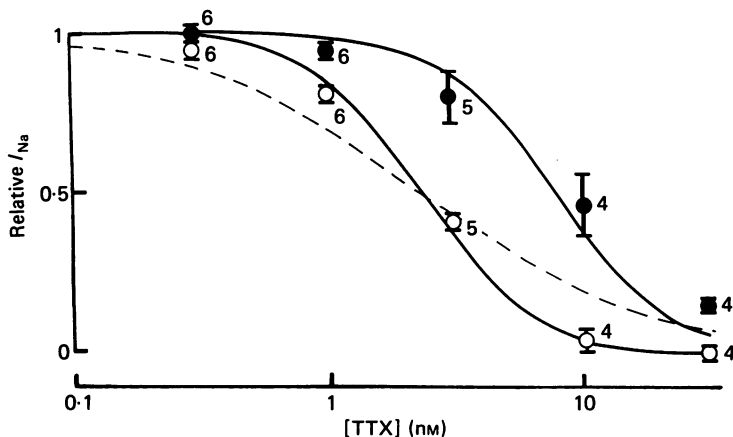

Fig. 5. Tetrodotoxin dose-response curves for fast and slow currents. Fast (open circles) and slow (filled circles) currents are extrapolated values to time zero of fast and slow phases of inactivation. The currents were normalized to their respective values in the absence of TTX. Mean values and s.e. of the mean obtained in four to six experiments. The numbers besides each point give the number of experiments. The dashed curve represents the inhibition of the fast current assuming a one-to-one reaction between channels and TTX molecules, with a dissociation constant of 2.3 nM. The continuous curves were calculated from eqn. (2) with $K = 2.3$ nM (fast current) and 7.8 nM (slow current). Temperature: 13–15 °C.

it was of interest to study the effects of the most widely used natural toxin: TTX, on $I_{\text{Na},f}$ and $I_{\text{Na},s}$. Fig. 4 presents traces of Na current and representations in semilogarithmic coordinates of their inactivation phases, in the absence and in the presence of 3 and 10 nM-TTX. In each solution, the Na current was recorded during depolarizations to 0 mV, preceded by 50 ms hyperpolarizations to -120 mV. Surprisingly, the effects of TTX were very similar to those of niflumic acid. The inactivation time constants were not significantly modified (see also Table 1) and $I_{\text{Na},f}$ was more reduced than $I_{\text{Na},s}$. With 10 nM-TTX, while the fast inactivation phase was almost completely blocked, the slow inactivation phase was only reduced to about half of its control value. Similarly to what was observed with niflumic acid, TTX significantly increased the time to peak of I_{Na} . Fig. 5 represents dose-response curves of the effects of TTX on $I_{\text{Na},f}$ and $I_{\text{Na},s}$. The points are mean values of I_{Na,t_0} and I_{Na,s_0} normalized to their respective values in control solution. Fast and slow Na currents were reduced to 50% of their control values by 2 and 10 nM-TTX respectively. Furthermore, similarly to what was observed with niflumic acid, the block of $I_{\text{Na},f}$ and $I_{\text{Na},s}$ cannot be described by a one-to-one reaction between

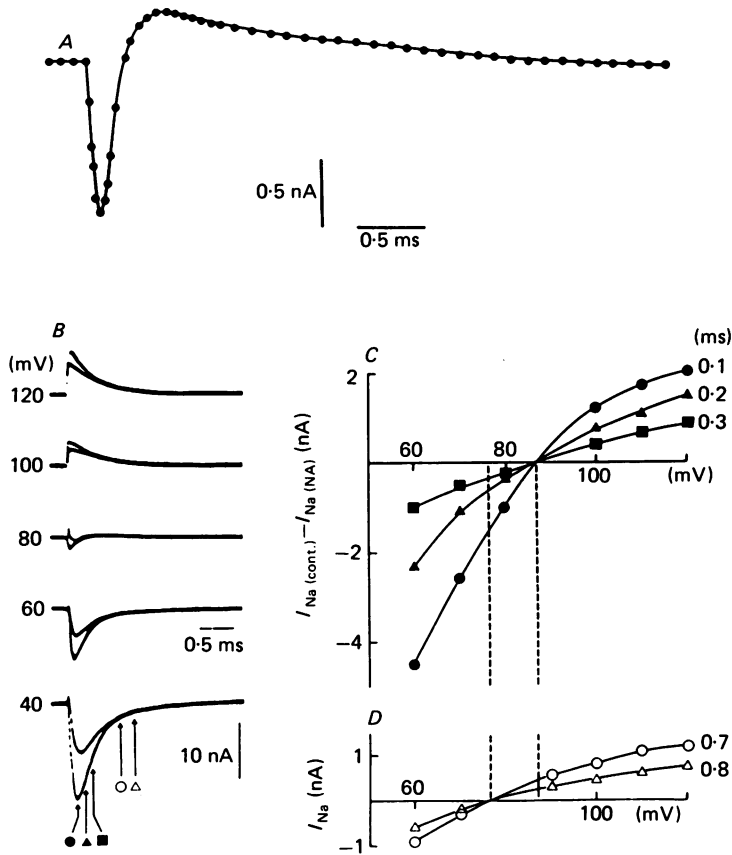

Fig. 6. Reversal potentials of fast and slow currents. *A*, Na current calculated as the difference between current traces recorded in control solution and in the presence of 300 nM-TTX, during depolarizations to +80 mV from a holding potential of -100 mV. Temperature: 14 °C. Fibre: 25-05-84. *B*, traces of Na current near its reversal potential without and with niflumic acid (NA) (2 mM). The depolarizations were preceded by 50 ms hyperpolarizations to -160 mV. *C*, fast current as a function of membrane potential. The current was calculated as the difference ($I_{\text{Na(cont.)}} - I_{\text{Na(NA)}}$) between the traces in each pair of records in *B*, after 0.1 ms (circles), 0.2 ms (triangles) and 0.3 ms (squares) depolarizations (arrows and filled symbols in *B*). *D*, slow current as a function of membrane potential. The current was measured after 0.7 ms (circles) and 0.8 ms (triangles) depolarizations (arrows and open symbols in *B*). In *C* and *D*, the dashed lines indicate the reversal potentials of fast and slow currents. Temperature: 13 °C. Fibre: 14-06-83.

channels and TTX molecules (dashed curve), but is well fitted if one assumes that two TTX molecules react with one channel (see Discussion).

Reversal potentials

In the frog node of Ranvier, the peak Na current recorded near its reversal potential is never nil but presents an initial inward phase followed by an outward phase (see Fig. 6*A* and Sigworth, 1981, Fig. 1). A possible explanation for this phenomenon is that $I_{\text{Na,f}}$ and $I_{\text{Na,s}}$ do not reverse at the same voltage. In order to test this

hypothesis, we recorded I_{Na} at various voltages near its reversal potential in control solution and after addition of 2 mM-niflumic acid (Fig. 6*B*). Since the slow current was almost unaffected by 2 mM-niflumic acid, the difference between currents without and with niflumic acid gives the blocked current (i.e. a part of the fast current). In the experiment presented in Fig. 6, the fast current reversed near +85 mV and its reversal potential remained the same at different times of current decay (Fig. 6*C*).

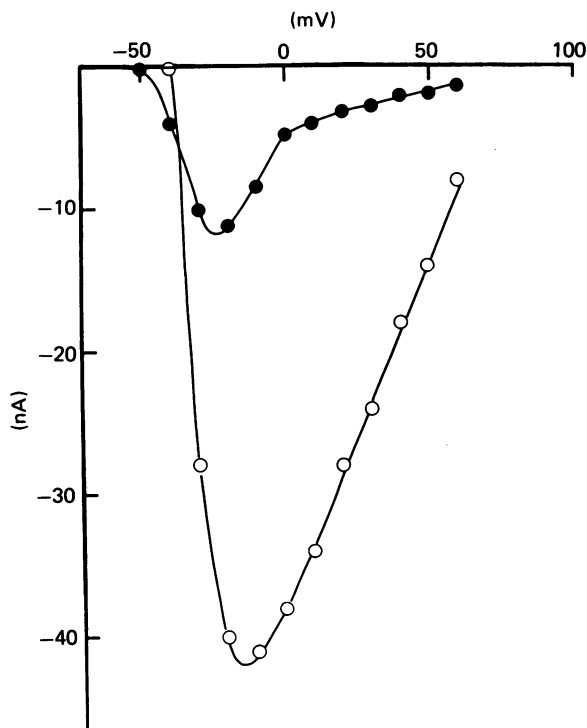

Fig. 7. Fast and slow current-voltage curves. Fast (open circles) and slow (filled circles) currents are extrapolated values to time zero of fast and slow phases of inactivation. Na currents were recorded during depolarizations of various amplitudes preceded by 50 ms hyperpolarizations to -120 mV. Temperature: 14°C . Fibre: 03-11-83.

In the same experiment, the current not blocked by niflumic acid (i.e. the slow current) reversed near +75 mV (Fig. 6*D*). These observations suggest that the change in reversal potential ($V_{\text{rev.}}$) of the compound I_{Na} during depolarizations to near $V_{\text{rev.}}$, is not due to a voltage-clamp artifact, but is a consequence of different reversal potentials and time courses of fast and slow currents. Assuming that in our experimental conditions, $V_{\text{rev.}}$ was only determined by external Na and internal Cs, it can be calculated from Fig. 6, that the selectivity ($P_{\text{Na}}/P_{\text{Cs}}$) of fast channels was 1.5 larger than that of slow channels.

Current-voltage curves

In order to analyse the activation-voltage dependence of fast and slow currents, we recorded the compound I_{Na} during depolarizations of various amplitudes

preceded by 50 ms hyperpolarizations to -120 mV. For each voltage, the inactivation time course of I_{Na} was separated into fast and slow phases as shown in Figs. 2 and 4. The values of I_{Na,r_0} and I_{Na,s_0} were plotted against voltage (Fig. 7).

It must be noted that near -40 mV, only one phase of inactivation can be shown. The question arises whether this current corresponds to fast, slow or both fast and slow components. We observed that the current near -40 mV was practically unaffected by 2 mM-niflumic acid. This observation led us to conclude that the

TABLE 1. Inactivation time constants

	$\tau_{h,r}$ (ms)	$\tau_{h,s}$ (ms)
Control	0.61 ± 0.03 ($n = 22$)	3.03 ± 0.37 ($n = 22$)
Niflumic acid	0.65 ± 0.04 ($n = 20$)	3.23 ± 0.29 ($n = 22$)
TTX	0.59 ± 0.02 ($n = 19$)	2.98 ± 0.31 ($n = 25$)
Pre-pulse	0.72 ± 0.03 ($n = 16$)	3.17 ± 0.19 ($n = 20$)

The inactivation time constants were calculated in control (without drug or without pre-pulse), in the presence of 0.1–10 mM-niflumic acid, 0.3 to 30 nM-TTX or 50 ms pre-pulses of various amplitudes to between -110 and -50 mV. Mean \pm s.e. of mean of n determinations.

current near -40 mV was exclusively a slow current (see also Fig. 13) which, consequently, activates at more negative voltages than $I_{\text{Na},r}$. Furthermore, it is interesting to note that the slope of the slow current–voltage relation changes abruptly near 0 mV (see also Fig. 13). This phenomenon, always observed in our experiments, should be further analysed. It may suggest that slow channels have two distinct open states (with different elementary conductances) whose probability of appearance is voltage dependent.

Steady-state inactivation curves

In the experiment presented in Fig. 8, the compound I_{Na} was recorded during depolarizations to -10 mV preceded by 50 ms pulses of various amplitudes. The inactivation time course of I_{Na} was separated into fast and slow phases and their amplitudes, normalized to their respective values for large prehyperpolarizations, were plotted against pre-pulse voltage, giving the familiar steady-state inactivation parameter (h_∞)– V curves for both components (Fig. 8A). First of all, it must be noted that the time constants of slow (Fig. 8B and C) and fast inactivations were not modified by the pre-pulse amplitude (see Table 1). Fig. 8A shows that the slopes of fast and slow h_∞ – V curves are different. Assuming symmetrical occupancy of the open state of the h system, the h_∞ – V curves were fitted by the equation:

$$h_\infty = 1/[1 + \exp(V - \bar{V})/k], \quad (3)$$

where \bar{V} was the membrane potential for $h_\infty = 0.5$ and k the steepness factor. For four similar experiments, the respective values of \bar{V} and k were (mean \pm s.e. of mean) -65.5 ± 0.7 mV and 6.3 ± 0.8 mV for the fast current and -64.8 ± 3.2 mV and 13.1 ± 3.0 mV for the slow current.

From these observations, it appears that with a pre-pulse near -50 mV, the fast current is almost fully inactivated whereas the slow current is only partly reduced.

This point is illustrated in Fig. 8 *B* and *C* which show, in semilogarithmic coordinates, the inactivation time course of I_{Na} after pre-pulses to -70 mV (*B*) and -50 mV (*C*). With the pre-pulse to -50 mV, only one phase of inactivation can be shown, corresponding to the reduced slow phase observed with more negative pre-pulses. These findings show that, in addition to pharmacological manipulations, fast and slow currents can be separated by pre-pulses of various amplitudes.

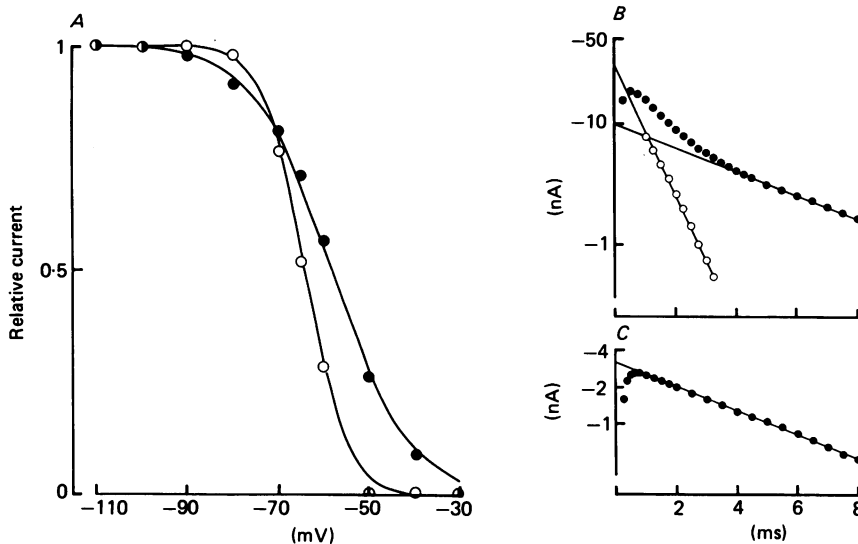

Fig. 8. Steady-state inactivation curves of fast and slow currents. *A*, fast (open circles) and slow (filled circles) steady-state inactivation curves. Na currents were recorded during depolarizations to -10 mV preceded by 50 ms pulses of various amplitudes. The points are extrapolated values to time zero of fast and slow phases of inactivation, normalized respectively to their values for large prehyperpolarizations. The curves were calculated from eqn. (3). The values of the parameters \bar{V} and k were respectively -64 mV and 4.5 mV (fast) and -58 mV and 8.5 mV (slow). *B* and *C*, representations in semilogarithmic coordinates of the inactivation phases of I_{Na} recorded with a pre-pulse to -70 mV (*B*) and -50 mV (*C*). $\tau_{h,f}$ is 0.82 ms (*B*). $\tau_{h,s}$ is 4.48 ms (*B*) and 4.36 ms (*C*). Holding potential: -110 mV. Temperature: 11°C . Fibre: 15-12-83.

Recovery from inactivation

In the node of Ranvier, the recovery from inactivation of the peak I_{Na} has been described by one (Chiu, 1977) or two (Ochs *et al.* 1981) exponentials, starting after an initial delay. This has been interpreted as resulting from the existence of two inactivated (Chiu, 1977) or two open (Ochs *et al.* 1981) states of the channels. Following the observations described above, it was of interest to see whether the existence of several phases in the recovery from inactivation could also be explained by the existence of two types of channels. In order to test this hypothesis, we recorded I_{Na} during test pulses applied at various times after a pre-pulse. The current was measured either 0.25 or 3 ms after the beginning of test pulses, corresponding respectively to time to peak and time for which the fast current was fully inactivated. When measured at 0.25 ms, the recovery could be fitted by the sum of two

exponentials and an initial delay (Fig. 9A). When measured at 3 ms (Fig. 9B), the recovery could be fitted by a single exponential without delay and with a time constant very similar to that of the slow phase of recovery measured at 0.25 ms. These observations suggest that fast and slow phases in Fig. 9 correspond to recovery from inactivation of fast and slow channels respectively. Moreover, the existence of a delay

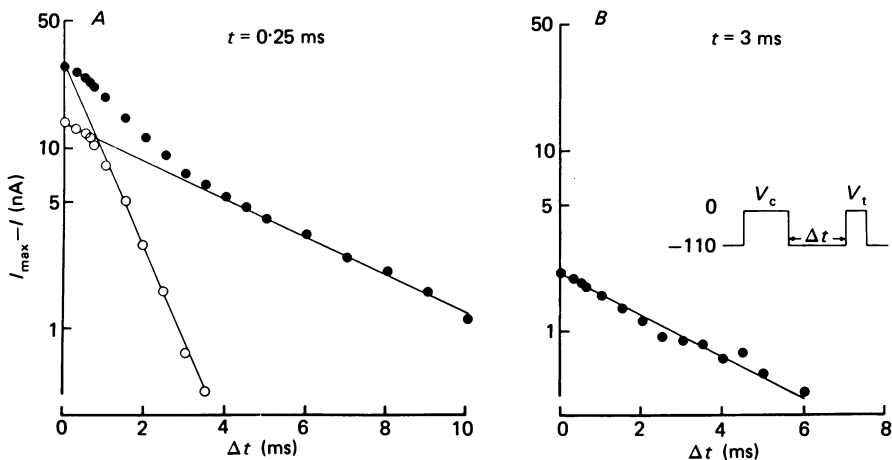

Fig. 9. Recovery from inactivation of fast and slow currents. Na currents were recorded during test depolarizations (V_t) to 0 mV at various times (Δt) after a 15 ms conditioning pulse (V_c) to 0 mV. The current was measured either 0.25 ms (A) or 3 ms (B) after the beginning of test pulses. Note that after 0.25 ms test depolarization, the recovery from inactivation could be described by the sum of two exponentials, plus a delay. After 3 ms test depolarization, the fast current was fully inactivated whatever the value of Δt , and the recovery from inactivation could be described by a single exponential. $\tau_{h,f}$ is 0.88 ms (A). $\tau_{h,s}$ is 3.96 ms (A) and 3.95 ms (B). Holding potential: -110 mV. Temperature: 14 °C. Fibre: 14-03-83. Maximum current, I_{\max} .

in the recovery measured at 0.25 ms and the absence of delay in the recovery measured at 3 ms may suggest that fast channels have two inactivated states, but slow channels have only one inactivated state. However, considering the relative lack of precision in the measurement of currents after partial inactivation, this conclusion will have to be confirmed by further experiments.

Turn-on kinetics

The preceding results show that fast and slow currents have different inactivation kinetics and different voltage dependencies. The question arises whether they also have different turn-on kinetics. Figs. 1, 2 and 4 show that the time to peak of the compound I_{Na} is increased by niflumic acid and TTX. Taking into account the differential effects of these drugs on $I_{Na,f}$ and $I_{Na,s}$, these observations suggest that $I_{Na,s}$ activates more slowly than $I_{Na,f}$. This conclusion is confirmed by the experiments presented in Fig. 10. I_{Na} was recorded successively either in control solution and in the presence of TTX (10^{-8} M) or in control solution and in the presence of niflumic acid (10^{-3} M). From the traces of I_{Na} with and without drug, the turn-on

time courses of $I_{\text{Na},f}$ and $I_{\text{Na},s}$ were calculated. Both start after an initial delay, and $I_{\text{Na},s}$ activates about three times more slowly than $I_{\text{Na},f}$.

Effects of large prehyperpolarizations

In squid axon, *Myxicola* axon and myelinated nerve fibre, prehyperpolarizations have two effects on I_{Na} . They increase I_{Na} by decreasing the steady-state inactivation

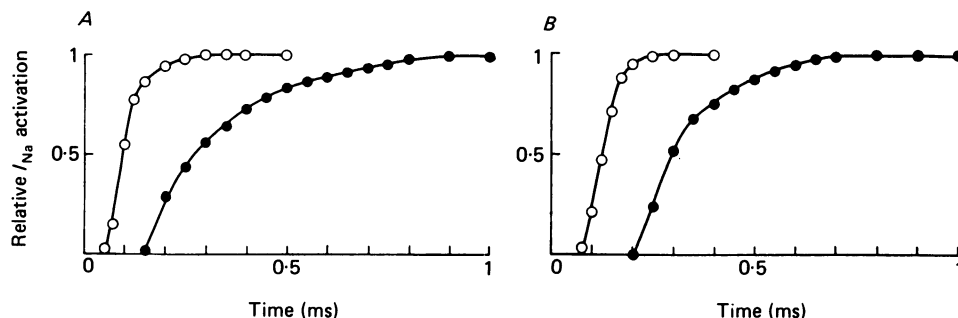

Fig. 10. Activation time courses of fast and slow currents. Na currents were recorded either during depolarization to 0 mV preceded by 50 ms hyperpolarizations to -110 mV (A) or during depolarizations to -10 mV from a holding potential of -110 mV (B), in control solution and in the presence of 10 nM-TTX (A) or in control solution and in the presence of 1 mM-niflumic acid (B). Activation time courses of fast (open circles) and slow (filled circles) currents were calculated from the traces of current without and with TTX (A) or without and with niflumic acid (B) if one assumes independence between activations and inactivations. Curves drawn by eye. Temperature: 13°C (A), 12°C (B). Fibres: 27-09-83 (A), 09-12-83 (B).

(increase of h_∞), and they delay the I_{Na} turn-on (Armstrong & Bezanilla, 1974; Keynes & Rojas, 1976; Neumcke, Nonner & Stämpfli, 1976; Chiu, 1977; Hahn & Goldman, 1978; Schauf, 1983; Taylor & Bezanilla, 1983). The delay in Na activation is usually interpreted as resulting from the existence of several closed states of the channels with an increased probability of channels being in the fully closed state at large hyperpolarizations. In the following experiment, we studied the effects of large prehyperpolarizations on $I_{\text{Na},f}$ and $I_{\text{Na},s}$. 50 ms pulses to -110 and -140 mV were successively applied before a given test pulse. In such conditions, fast and slow steady-state inactivations were nil ($h_\infty = 1$) (see Fig. 8), and the effects of prehyperpolarizations on the time course of I_{Na} could be studied alone. When recorded during a test pulse to -10 mV, the peak I_{Na} consisted mainly of fast current (see Fig. 7). In such a condition, a prehyperpolarization to -140 mV (instead of -110 mV) delayed both the activation and the inactivation, which induced an increase in time to peak without affecting peak I_{Na} amplitude (Fig. 11A). When recorded during a test pulse to -43 mV, I_{Na} consisted mainly of slow current (see Fig. 7) and a prehyperpolarization to -140 mV (instead of -110 mV) delayed the activation, but had no effect on the inactivation. Consequently, an increase in time to peak and a decrease in peak I_{Na} amplitude were induced (Fig. 11B). When recorded during a test pulse to -10 mV, but in the presence of 10 nM-TTX, I_{Na} consisted mainly of slow current (see Figs. 4 and 5). In such conditions, the prehyperpolarization to

–140 mV (instead of –110 mV) had the same effects as when I_{Na} was recorded at –43 mV without TTX, i.e. the activation was delayed, the inactivation remained unchanged and consequently the time to peak was increased and the amplitude of the peak I_{Na} was reduced (Fig. 11C). These observations show that large prehyperpolarizations have different effects on the time course of fast and slow currents. They

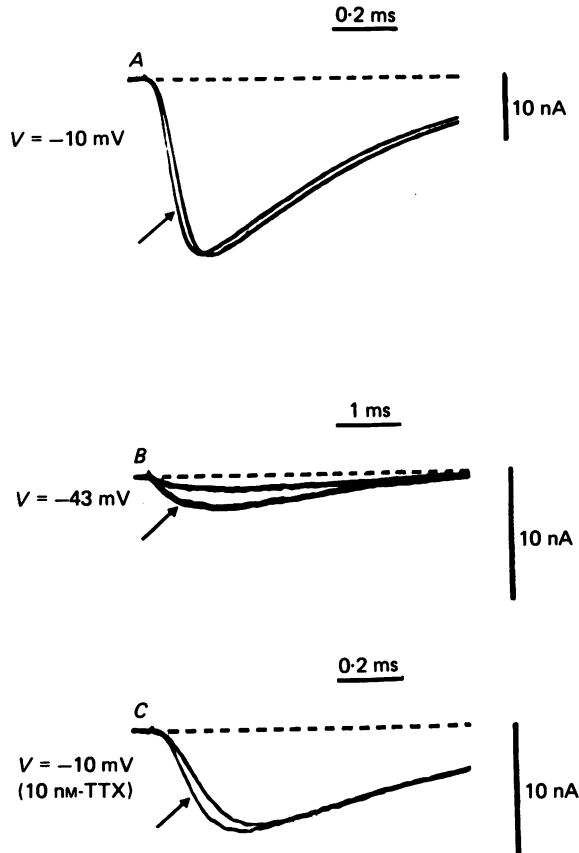

Fig. 11. Effects of large hyperpolarizing pre-pulses on fast and slow currents. Na currents were recorded after 50 ms prehyperpolarizations to –110 mV (arrows) and –140 mV during depolarizations to –10 mV in control solution (A), to –43 mV in control solution (B) and to –10 mV in control solution plus 10 nM-TTX (C). Temperature: 12 °C. Fibre: 09-12-83.

suggest that conformational changes of the two types of channels result from different mechanisms (see Discussion).

Effects of temperature

In the squid axon, Matteson & Armstrong (1982) provided evidence for the existence of two forms (normal and sleepy) of the Na channel, at low temperature. In order to see whether a similar conclusion could be drawn for the node of Ranvier, we analysed the effects of temperature (between 3 and 17 °C) on $I_{\text{Na},f}$ and $I_{\text{Na},s}$.

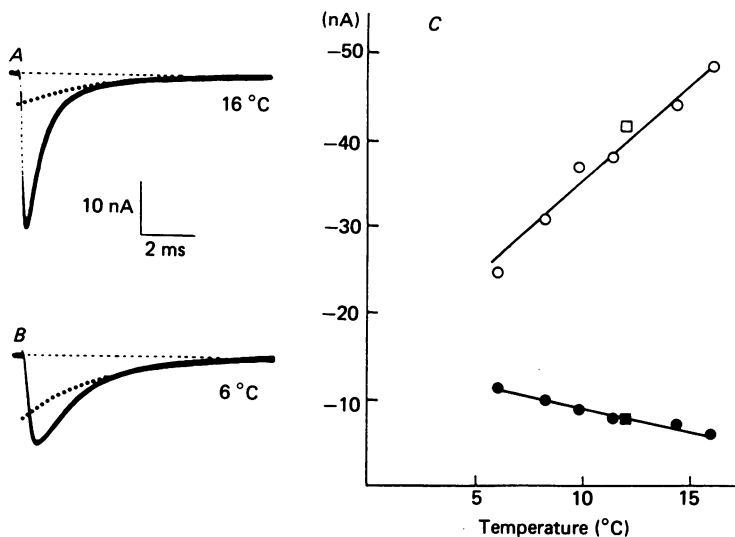

Fig. 12. Effects of temperature on fast and slow current amplitude. *A* and *B*, traces of Na current during depolarizations to -10 mV preceded by 50 ms hyperpolarizations to -120 mV at 16°C (*A*) and 6°C (*B*). Filled circles give extrapolations of the slow inactivation phase. $\tau_{h,f}$, $\tau_{h,s}$ and $I_{\text{Na},s_0}/I_{\text{Na},f_0}$ are respectively: 0.50 ms, 2.47 ms and 0.14 (16°C) and 0.85 ms, 2.55 ms and 0.47 (6°C). *C*, amplitude of fast (open symbols) and slow (filled symbols) currents extrapolated to time zero as a function of temperature. Same protocol as in *A* and *B*. The currents were recorded during lowering of the temperature (circles) and after rewarming (squares). Curves drawn by eye. Fibre: 03-11-83.

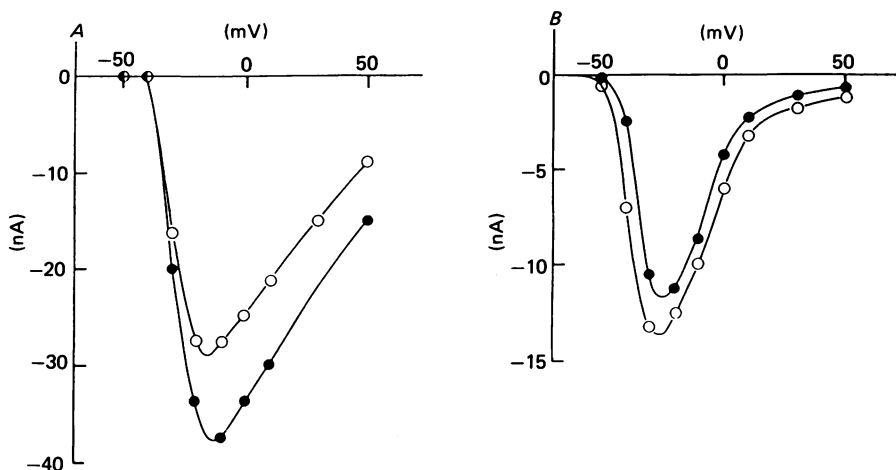

Fig. 13. Fast (*A*) and slow (*B*) current-voltage curves at 15°C (filled circles) and 4°C (open circles). The currents were recorded during depolarizations of various amplitudes preceded by 50 ms hyperpolarizations to -120 mV. The points are extrapolated values to time zero of fast and slow inactivation phases. Fibre: 17-11-83.

Values of I_{Na,f_0} and I_{Na,s_0} were plotted against temperature as shown in Fig. 12. The most important point was that whereas I_{Na,f_0} decreased, I_{Na,s_0} increased at low temperature. This conclusion, confirmed at various membrane potentials (Fig. 13) will be discussed below. In Fig. 13, I_{Na,f_0} and I_{Na,s_0} are not represented for potentials more positive than +50 mV (see also Fig. 7). For large depolarizations, the separation of $I_{\text{Na},f}$ and $I_{\text{Na},s}$ was not possible because of the very small amplitude of $I_{\text{Na},s}$.

TABLE 2. Q_{10} s of various parameters

Fibre	$\tau_{h,f}^{-1}$	$\tau_{h,s}^{-1}$	$I_{\text{Na},f_0} + I_{\text{Na},s_0}$	$\frac{I_{\text{Na},f_0}}{I_{\text{Na},s_0}}$
27-9-83	1.40	2.17	1.09	2.55
4-10-83	2.24	1.99	1.70	1.68
25-10-83	2.67	1.89	1.40	3.83
26-10-83	1.72	2.20	1.37	1.61
27-10-83	2.14	1.90	1.96	2.14
3-11-83	1.60	1.04	1.44	3.30
17-11-83	1.53	1.64	1.25	3.34
Mean \pm S.E. of mean	1.90 ± 0.17	1.83 ± 0.15	1.46 ± 0.12	2.64 ± 0.36

For this, it was difficult to get precise differences between reversal potentials of $I_{\text{Na},f}$ and $I_{\text{Na},s}$ at high and low temperatures. However, when considering the peak current, in agreement with the Nernst equation, its reversal potential at 4 °C, compared with its value at 15 °C, was shifted by about 3 mV towards negative voltages. We calculated Q_{10} s of various parameters (Table 2). Assuming negligible changes in Na driving force with temperature, Q_{10} of $I_{\text{Na},f_0} + I_{\text{Na},s_0}$ represents the Q_{10} of the conductance. Q_{10} s of $\tau_{h,f}$, $\tau_{h,s}$ and the conductance are very similar to those found previously considering the over-all inactivation (see Collins & Rojas, 1982).

DISCUSSION

The major findings in this paper can be summarized as follows. (1) Na inactivation exhibits two phases. (2) The slow phase of Na inactivation is less sensitive to niflumic acid and TTX than the fast phase of Na inactivation. (3) Fast and slow Na currents (as defined from their rate of inactivation) reverse at different potentials, have different activation- and inactivation-voltage dependencies, have different kinetics of recovery from inactivation and different kinetics of activation. (4) Large prehyperpolarizations delay both the activation and the inactivation of the fast current but delay only the activation of the slow current. (5) Low temperatures decrease the fast current but increase the slow current. (6) The dose-response relations of the effects of niflumic acid and TTX on the fast current are better fitted if one assumes that two molecules of drug react with each channel rather than one.

Two types of Na channels

The differential effects of niflumic acid and TTX on fast and slow phases of inactivation and the different time and voltage dependencies of fast and slow currents suggest the existence of two different types of channels. Alternatively, one can assume

only one population of channels with two distinct open (Ochs *et al.* 1981) or inactivated (Chiu, 1977) states. In the case of one population of channels with two open or inactivated states, the channels should be differentially blocked by niflumic acid or TTX in their different open or inactivated states and thus, the kinetics of Na inactivation should be altered by TTX or niflumic acid. Since this is not the case, we conclude that two different populations of Na channels with different sensitivities to niflumic acid, TTX and voltage, different ionic selectivities and different activation and inactivation kinetics, exist.

Activation-inactivation coupling

Concerning the effects of prehyperpolarizations on the time course of both currents, our results can help to reconcile the different models already proposed which suppose that activation and inactivation are either coupled or not (see review by French & Horn, 1983). From our results (Fig. 11), we conclude that activation and inactivation are coupled (or partly coupled) in fast channels but are independent in slow channels. Schemes (A) and (B) summarize these conclusions:

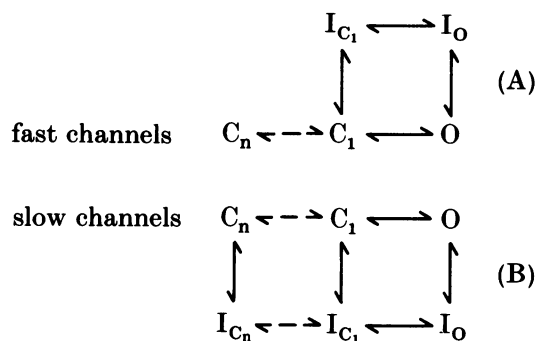

C, O and I are respectively closed, open and inactivated states of the channels. We assume that large prehyperpolarizations increase the probability of fast and slow channels to be in C_n state and that slow channels can inactivate when they are in C_n state but not fast channels. Consequently, large prehyperpolarizations delay the activation of both fast and slow channels but only delay the inactivation of fast channels. A second inactivated state I_{C₁}, by passing the open state of fast channels (Armstrong & Gilly, 1979), was introduced in order to take into account the facts that: (a) the channels do not conduct significantly during recovery from inactivation (see Armstrong & Croop, 1982); (b) in the voltage range -50 to -100 mV, the fast channels have a larger probability to inactivate than to open (see Figs. 7 and 8).

Two TTX molecules are necessary to block one channel

Our results suggest that two molecules of niflumic acid and TTX are necessary to block one channel. This conclusion deserves attention since, to our knowledge and except for the block of Na channels in the frog node of Ranvier by Triton X-100 (Brismar & Rydqvist, 1978) a Hill coefficient near 1 was always found for a block of ionic channels. The effects of niflumic acid are very similar to those of local anaesthetics for which it is assumed that one molecule blocks one channel. Taking

into account the lack of information on the effects of niflumic acid on axons, we shall concentrate the discussion on the effects of TTX for which many reports are available.

A plot in double logarithmic coordinates (Hill plot) of our data gave Hill coefficients (n_H) of 1.68 with $r^2 = 0.97$ (calculated from mean values for each TTX concentration) and 1.48 ± 0.24 with $r^2 \geq 0.90$ (calculated from mean n_H s of five experiments) for the fast current. For the slow one, n_H s of 1.35 with $r^2 = 0.99$ (calculated from mean values for each TTX concentration) and 1.19 ± 0.29 with $r^2 \geq 0.90$ (calculated from mean n_H s of five experiments) were found. One explanation for such values could be that, in our experiments, the effects of TTX were not stationary. This seems unlikely since the membrane was exposed to TTX for 3–8 min in each solution before I_{Na} was recorded. A Hill coefficient larger than 1 suggests the existence of at least two co-operative TTX receptors per channel. The fact that the Hill coefficient is smaller for the slow current than for the fast one, can be explained either by different co-operativities, or by different mechanisms of TTX reaction with the two types of channels. This point needs further experiments to be clarified. When the peak Na current was considered, we found n_H s of 1.17 with $r^2 = 0.99$ (calculated from mean values for each TTX concentration) and 1.17 ± 0.09 with $r^2 \geq 0.98$ (calculated from mean n_H s of five experiments). Such values can be explained, from our results, by different sensitivities for TTX (see Fig. 5) and different time courses and proportions (see Figs. 4 and 10) of the two components. We conclude that there should exist more than one TTX receptor per channel. This idea is in contrast with most previous reports. However, two arguments can be extracted from the literature in favour of this conclusion. (1) Reviewing the literature on TTX and saxitoxin, Ritchie & Rogart (1977) pointed out that it was not definitively established that a single toxin molecule combines with a single Na channel. They concluded that one 'could not exclude the possibility that two molecules of toxin were reacting with each receptor'. (2) On the basis of fluorescence resonance energy transfer experiments, Angelides & Nutter (1984) concluded that at least two TTX receptors are interacting or closely arranged, and they represented the channel with three TTX-binding components forming the ion-conducting pore. If there really exists more than one TTX receptor per channel, previous conclusions on the interaction of TTX with Na channels must be reconsidered. However, taking into account the inaccuracies in determinations of I_{Na, t_0} and I_{Na, s_0} , further investigations are required to confirm this point.

Interconversion of fast and slow channels

The effects of low temperatures on $I_{Na, s}$ can be explained by at least three interpretations: (a) an increase in elementary conductance of slow channels; (b) an induction of new conducting channels or new conducting states of channels; (c) a transformation of fast channels into slow channels. The first interpretation seems very unlikely since it is difficult to imagine that the elementary conductance increases with a decrease in temperature. The second interpretation can be supported by the observation that, in the node of Ranvier, the maximum charge movement increases with lowering of the temperature (Collins & Rojas, 1982). However, it must be noted that this observation can also be in favour of the transformation hypothesis if one assumes that the gating particles of slow channels have a larger effective valence than the gating particles of fast channels. An induction of conducting Na channels by

long-lasting depolarizations has been reported in *Xenopus laevis* oocyte (Baud, Kado & Marcher, 1982). However, this induction was decreased at low temperatures (C. Baud & R. T. Kado, personal communication). Consequently, we think that, in the node of Ranvier, the transformation hypothesis is the most likely interpretation of the effects of temperature. This interpretation is very similar to that proposed by Matteson & Armstrong (1982) for normal and sleepy Na channels in the squid axon. At any temperature, there would exist an equilibrium between the two forms (F and S) of channels which can be represented by scheme (C)



where a and b are rate constants of transformation of channels. According to this scheme, fast and slow currents (I_{Na, f_0} and I_{Na, s_0}) are respectively equal to $b/(a+b)$ and $a/(a+b)$, multiplied by the respective elementary conductances and opening probabilities of fast and slow channels. With a change in temperature, one can assume that, at a given voltage, the product of the elementary conductance and the opening probability of fast channels divided by the product of the elementary conductance and the opening probability of slow channels, remains constant. Consequently, the Q_{10} of $I_{\text{Na}, f_0}/I_{\text{Na}, s_0}$ represents the Q_{10} of b/a (see Table 2). Further experiments are required to state more precisely the validity of the model proposed. In particular, it would be of interest to induce changes in a and b at a constant temperature. Since the proportion of fast and slow currents are dependent on temperature, it is tempting to think that fast and slow forms of the channel are related to different lipid environments of the protein forming the channel. It would be interesting to see whether changes in the lipid composition or the fluidity of the membrane could alter the proportion of fast and slow currents.

Concluding remarks

In the present report, we have not taken into consideration the small 'late' Na current which does not (or only very slowly) inactivate (Dubois & Bergman, 1975) (see Methods). In fact, three different Na currents probably exist in the node of Ranvier (fast, slow and late). It would be of interest to see whether the late current corresponds to a third form of the channel and whether drugs and toxins which slow down and partly suppress the inactivation would not in fact shift the equilibrium between forms towards the late one.

Several types of TTX-binding sites or Na currents have been demonstrated or suggested in squid axon (Sevcik, 1976; Matteson & Armstrong, 1982; Gilly & Armstrong, 1984); node of Ranvier (Dubois & Bergman, 1975; Sigworth, 1981; present report); cerebellar Purkinje fibres (Llinas & Sugimori, 1980); skeletal muscle fibre (Caillé, Ildefonse, Rougier & Roy, 1981; Jaimovich, Chicheportiche, Lombet, Lazdunski, Ildefonse & Rougier, 1983); cardiac cells (Coraboeuf, Deroubaix & Coulombe, 1979; Ten Eick, Yeh & Matsuki, 1984); rat myotubes (Lombet, Frelin, Renaud & Lazdunski, 1982); neuroblastoma cells (Nagy, Kiss & Hof, 1983) and *Xenopus* oocytes injected with poly(A)⁺ messenger RNA extracted from rat brain or cat muscles (Gundersen, Miledi & Parker, 1983). As demonstrated for K currents (see

Dubois, 1983), it appears that the existence of several Na currents is a common feature of excitable membranes. An important question is: do these currents correspond to different open states of one population of channels, different forms in equilibrium of one type of channel (tautochannels) or different non-interconvertible populations of channels (heterochannels)? *A priori*, these three possibilities can be thought to coexist and a definitive answer to this question must await further detailed investigations in different cells. Whatever the situation is, it is now clear that the 'sodium system' can no longer be interpreted in terms of one population of channels and previous conclusions on Na channel behaviour must be considered with some caution.

We thank UPSA Laboratoires for a generous gift of niflumic acid. We are grateful to H. Ducholier for participating in preliminary experiments and P. Guilbault for suggesting the initial experiments. We would like to express our warmest appreciation to E. Coraboeuf and A. Coulombe for their critical reading of the manuscript and helpful comments and suggestions during the progress of this work. We thank P. Richer for her assistance in the preparation of the manuscript. This work was supported by grants from MIR (83.C.0329 and 83.C.9012) and INSERM (CRE 836010).

REFERENCES

- ANGELIDES, K. J. & NUTTER, T. J. (1984). Molecular and cellular mapping of the voltage-dependent Na^+ channel. *Biophysical Journal* **45**, 31–34.
- ARMSTRONG, C. M. & BEZANILLA, F. (1974). Charge movement associated with the opening and closing of the activation gates of the Na channels. *Journal of General Physiology* **63**, 533–552.
- ARMSTRONG, C. M. & CROOP, R. S. (1982). Simulation of Na channel inactivation by thiazin dyes. *Journal of General Physiology* **80**, 641–662.
- ARMSTRONG, C. M. & GILLY, W. F. (1979). Fast and slow steps in the activation of sodium channels. *Journal of General Physiology* **74**, 691–711.
- BAUD, C., KADO, R. T. & MARCHER, K. (1982). Sodium channels induced by depolarization of the *Xenopus laevis* oocyte. *Proceedings of the National Academy of Sciences of the U.S.A.* **79**, 3188–3192.
- BRISMAR, T. & RYDQVIST, B. (1978). Effect of the nonionic detergent Triton X-100 on sodium permeability of the myelinated nerve fibre of *Xenopus laevis*. *Acta physiologica scandinavica* **102**, 425–433.
- BRÛLÉ, G., HAUDECOEUR, G., JDËIAA, H. & GUILBAULT (1983). Inhibition par une substance amphiphile, l'acide niflumique, de la rectification dans le sens entrant de la fibre musculaire de crustacé. *Archives internationales de physiologie et de biochimie* **91**, 269–277.
- CAILLÉ, J., ILDEFONSE, M., ROUGIER, O. & ROY, G. (1981). Surface and tubular membrane sodium currents in frog twitch muscle fibre; implication in excitation contraction coupling. *Advances in Physiological Sciences* **5**, 389–409.
- CHIU, S. Y. (1977). Inactivation of sodium channels: second order kinetics in myelinated nerve. *Journal of Physiology* **273**, 573–596.
- COLLINS, C. A. & ROJAS, E. (1982). Temperature dependence of the sodium channel gating kinetics in the node of Ranvier. *Quarterly Journal of Experimental Physiology* **67**, 41–55.
- CORABOEUF, E., DEROUBAIX, E. & COULOMBE, A. (1979). Effect of tetrodotoxin on action potential of the conducting system in the dog heart. *American Journal of Physiology* **234**, 561–567.
- CORBIER, A. & DUBOIS, J. M. (1983). Two transient Na currents in the frog node of Ranvier. *Journal of Physiology* **345**, 79P.
- COUSIN, J. L. & MOTAIS, R. (1979). Inhibition of anion permeability by amphiphilic compounds in human red cell: Evidence for an interaction of niflumic acid with the band 3 protein. *Journal of Membrane Biology* **46**, 125–153.
- DROUIN, H. & NEUMCKE, B. (1974). Specific and unspecific charges at the sodium channels of the nerve membrane. *Pflügers Archiv* **351**, 207–229.
- DUBOIS, J. M. (1983). Potassium currents in the frog node of Ranvier. *Progress in Biophysics and Molecular Biology* **42**, 1–20.

- DUBOIS, J. M. & BERGMAN, C. (1975). Late sodium current in the node of Ranvier. *Pflügers Archiv* **357**, 145–148.
- DUBOIS, J. M. & COULOMBE, A. (1984). Current-dependent inactivation induced by sodium depletion in normal and batrachotoxin-treated frog node of Ranvier. *Journal of General Physiology* **84**, 25–48.
- FOX, J. M. (1976). Ultra-slow inactivation of the ionic currents through the membrane of myelinated nerve. *Biochimica et biophysica acta* **426**, 232–244.
- FRENCH, R. J. & HORN, R. (1983). Sodium channel gating: models, mimics and modifiers. *Annual Review of Biophysics and Bioengineering* **12**, 319–356.
- GILLY, W. F. & ARMSTRONG, C. M. (1984). Threshold channels – a novel type of sodium channel in squid giant axon. *Nature* **309**, 448–450.
- GUNDERSEN, C. B., MILEDI, R. & PARKER, I. (1983). Voltage-operated channels induced by foreign messenger RNA in *Xenopus* oocytes. *Proceedings of the Royal Society B* **220**, 131–140.
- HAHN, R. & GOLDMAN, L. (1978). Initial conditions and the kinetics of the sodium conductance in *Myxicola* axons. I. Effects on the time-course of the sodium conductance. *Journal of General Physiology* **72**, 863–877.
- JAIMOVICH, E., CHICHEPORTICHE, R., LOMBET, A., LAZDUNSKI, M., ILDEFONSE, M. & ROUGIER, O. (1983). Differences in the properties of Na⁺ channels in muscle surface and T-tubular membranes revealed by tetrodotoxin derivatives. *Pflügers Archiv* **397**, 1–5.
- KEYNES, R. D. & ROJAS, E. (1976). The temporal and steady-state relationships between activation of the sodium conductance and movement of the gating particles in the squid giant axon. *Journal of Physiology* **255**, 157–189.
- KNIFFKI, K. D., SIEMEN, D. & VOGEL, W. (1981). Development of sodium permeability inactivation in nodal membranes. *Journal of Physiology* **313**, 37–48.
- LLINAS, R. & SUGIMORI, M. (1980). Electrophysiological properties of *in vitro* Purkinje cell somata in mammalian cerebellar slices. *Journal of Physiology* **305**, 171–195.
- LOMBET, A., FRELIN, C., RENAUD, J. F. & LAZDUNSKI, M. (1982). Na⁺ channels with binding sites of high and low affinity for tetrodotoxin in different excitable and non-excitable cells. *European Journal of Biochemistry* **124**, 199–203.
- MATTESON, D. R. & ARMSTRONG, C. M. (1982). Evidence for a population of sleepy sodium channels in squid axon at low temperature. *Journal of General Physiology* **79**, 739–758.
- NAGY, K., KISS, T. & HOF, D. (1983). Single Na channels in mouse neuroblastoma cell membrane. Indications for two open states. *Pflügers Archiv* **399**, 302–308.
- NEUMCKE, B., NONNER, W. & STÄMPFLI, R. (1976). Asymmetrical displacement current and its relation with the activation of sodium current in the membrane of frog myelinated nerve. *Pflügers Archiv* **363**, 193–203.
- NEUMCKE, B. & STÄMPFLI, R. (1982). Sodium currents and sodium-current fluctuations in rat myelinated nerve fibres. *Journal of Physiology* **329**, 163–184.
- NEUMCKE, B. & STÄMPFLI, R. (1983). Alteration of the conductance of Na⁺ channels in the nodal membrane of frog nerve by holding potential and tetrodotoxin. *Biochimica et biophysica acta* **727**, 177–184.
- NONNER, W. (1969). A new voltage clamp method for Ranvier nodes. *Pflügers Archiv* **309**, 116–192.
- NONNER, W. (1980). Relations between the inactivation of sodium channels and the immobilization of gating charge in frog myelinated nerve. *Journal of Physiology* **299**, 573–603.
- OCHS, G., BROMM, B. & SCHWARZ, J. R. (1981). A three-state model for inactivation of sodium permeability. *Biochimica et biophysica acta* **645**, 243–252.
- RITCHIE, J. M. & ROGART, R. B. (1977). The binding of saxitoxin and tetrodotoxin to excitable tissue. *Reviews of Physiology, Biochemistry and Pharmacology* **79**, 1–50.
- SCHAUF, C. L. (1983). Insensitivity of activation delays in potassium and sodium channels to heavy water in *Myxicola* giant axon. *Journal of Physiology* **337**, 173–182.
- SCHWARZ, J. R., BROMM, B., SPIELMAN, R. P. & WEYJTJENS, J. L. F. (1983). Development of Na inactivation in motor and sensory myelinated nerve fibres of *Rana esculanta*. *Pflügers Archiv* **398**, 126–129.
- SCHWARZ, W. (1979). Temperature experiments on nerve and muscle membranes of frogs. Indications for a phase transition. *Pflügers Archiv* **382**, 27–34.
- SEVCIK, C. (1976). Binding of tetrodotoxin to squid nerve fibers. Two kinds of receptors? *Journal of General Physiology* **68**, 95–103.

- SIGWORTH, F. J. (1980). The variance of sodium current fluctuations at the node of Ranvier. *Journal of Physiology* **307**, 97–129.
- SIGWORTH, F. J. (1981). Covariance of nonstationary sodium current fluctuations at the node of Ranvier. *Biophysical Journal* **34**, 111–133.
- TAYLOR, R. E. & BEZANILLA, F. (1983). Sodium and gating current time shifts resulting from changes in initial conditions. *Journal of General Physiology* **81**, 773–784.
- TEN EICK, R., YEH, J. & MATSUKI, N. (1984). Two types of voltage dependent Na channels suggested by differential sensitivity of single channels to tetrodotoxin. *Biophysical Journal* **45**, 70–73.