

STATISTICS OF THE MAINTAINED DISCHARGE OF CAT RETINAL GANGLION CELLS

BY L. J. FRISHMAN AND M. W. LEVINE*

*From the Departments of Engineering Sciences and Biological Sciences and the
Biomedical Engineering Center, Northwestern University, Evanston, IL 60201, U.S.A.*

(Received 9 June 1982)

SUMMARY

1. Action potentials were recorded from single fibres in the optic tracts of anaesthetized cats. Continuous records were obtained at various levels of scotopic and mesopic retinal illumination. In some cases, the light intensity was modulated by a pseudorandom Gaussian white-noise signal.

2. The maintained discharge of on-centre neurones increased while the maintained discharge of off-centre neurones decreased with increased illumination of the receptive field centre. For both cell types, the coefficient of variation declined with increased rate of discharge.

3. There was minimal short-term dependency in the firing patterns, and it was unaffected by the level of retinal illumination. Virtually all of the structure revealed by the normalized autocovariance functions could be attributed to the shape of the interval distributions. The first few coefficients of the serial correlogram were slightly negative. The magnitude of this negativity was not related to illumination.

4. Long-term dependency in the firing pattern was also quite small; the standard deviations of the mean rate in samples of about 1 sec duration were only slightly less than would be predicted from the interval distributions. This dependency tended to increase at higher retinal illuminations.

5. Neural discharges elicited by Gaussian modulation of the light were strikingly different from those elicited by steady light. Modulation caused the first coefficient of the serial correlogram to become more positive, while the next several coefficients became more negative. A corresponding pattern could be seen in the normalized autocovariance functions, and in the differences between the normalized autocovariance and normalized autoconvolution. Long-term dependency also increased dramatically, such that the standard deviations of mean rate were about 60% of what would be expected given the interval distributions observed.

6. These results place a number of constraints upon the ways in which intrinsic noise in the retina may enter the visual processing network. Two alternative models consistent with the data are presented.

* Department of Psychology, University of Illinois at Chicago, Chicago, IL 60680, U.S.A.

INTRODUCTION

Retinal ganglion cells in the cat produce maintained activity under most conditions, and there have been several studies of the statistical properties of this activity (e.g. Kuffler, FitzHugh & Barlow, 1957; Rodieck, 1967; Barlow & Levick, 1969; Barlow, Levick & Yoon, 1971; Sato, Yamamoto & Nakahama, 1976). Previous investigators have analysed the statistical distribution of interspike intervals (Barlow & Levick, 1969; Barlow *et al.* 1971), and have asked how the mean rate and the variability of the mean rate change with adaptation level (Rodieck, 1967; Barlow & Levick, 1969; Sato *et al.* 1976). They have also looked at the statistical dependence between intervals, asking whether or not the time to the next spike is totally independent of the preceding interval. To date, the statistical measures that have been used, i.e. autocorrelation, joint interval histograms and serial correlation, have been measures of short-term dependency. Use of these measures has shown statistical dependency of maintained activity of cat retinal ganglion cells to be weak and variable (Rodieck, 1967; Sato *et al.* 1976), and the sources of it have remained obscure.

Recently, Levine (1980) has devised a method for examining statistical dependency over the long term. Using this method, he found that the mean firing rate of goldfish retinal ganglion cells is much less variable than would be predicted from sampling the interspike interval distribution. To investigate the source of this organization, Levine (1982) compared the statistical properties of the maintained discharge of the goldfish retina with the properties of the firing when extrinsic Gaussian white noise was applied. On the basis of these data, a model was proposed. The model specifies the locus of retinal noise as well as the characteristics and loci of filters which condition both the visual signal and intrinsic noise in the goldfish retina.

A main goal of the present study was to examine further the statistical dependency of maintained activity in the cat retina. Statistical properties of the maintained activity were compared at different levels of illumination and in the absence and presence of extrinsic noise. One finding was that the maintained activity in the cat retina is less organized both over the short and the long term than that in the goldfish retina. Two alternative models that account for our data from the cat retina are suggested, and these models are compared with a model previously proposed for the goldfish retina (Levine, 1982).

METHODS

Preparation and recording. Adult cats were prepared essentially according to techniques described elsewhere (Enroth-Cugell, Goldstick & Linsenmeier, 1980). Cats were pre-treated with 0.2 mg atropine sulphate and initially anaesthetized with halothane (Fluothane) in oxygen. Anaesthesia was maintained during surgical preparation with sodium thiamylal (Surital) given i.v.; light anaesthesia was maintained during recording with i.v. urethane (20–30 mg/kg.hr) following a loading dose of 200 mg/kg. The cervical sympathetic trunks were cut bilaterally, and paralysis was produced with gallamine triethiodide (Flaxedil; 20–40 mg/kg.hr i.v.) to ensure ocular stability. Mean arterial blood pressure was generally above 90 mmHg, and subscapular temperature was kept at about 38 °C. End-tidal CO₂ was maintained at 4% by adjusting the volume per minute of the respiration pump. Pupils were fully dilated with atropine, and the nictitating membranes were retracted with a weak solution (1–2%) of phenylephrine HCl. Clear contact lenses were chosen by direct ophthalmoscopy to make the eyes emmetropic.

Tungsten-in-glass electrodes (Levick, 1972) were placed in the optic tract. Impulses were amplified by conventional means, played through a loudspeaker, displayed on a cathode-ray tube and converted to standard pulses which were recorded by a PDP 11/10 computer and stored on floppy diskettes. Statistical analyses were performed off-line on a PDP 11/03 computer.

The position of the receptive field of each cell was plotted on a tangent screen in front of the cat. The positions of the optic disks were plotted on the same screen, and values given by Kinston, Vadas & Bishop (1969) were used to estimate the position of the area centralis.

Stimulation. Photic stimulation was produced by a three-channel Maxwellian view optical system originally described by Enroth-Cugell, Hertz & Lennie (1977), but modified to use high-power light-emitting diode (l.e.d.) light sources. The modified stimulator was designed for another experiment in which the rod and cone systems were stimulated separately by different channels; the data for the present experiment were collected during that other experiment (Levine & Frishman, 1981). In each of the two 'cone' channels, a red l.e.d. (Litronix LD52C) was used in combination with a red cut-off filter (Ilford 608) to give maximum light at 647 nm, with a maximum available mean retinal illumination of 1.9 log photopic trolands. In the one 'rod' channel, a green l.e.d. (General Instruments MV5252) was used in combination with a green interference filter (Balzer 539) to give maximum light at 542 nm, with a maximum available mean retinal illumination of 1.2 log photopic trolands. Retinal illuminations were calibrated with a United Detector Technology optometer (Model 40X) according to the method of Nygaard & Frumkes (1982). The output of the l.e.d.s was controlled over a 2 log unit range by pulse-width modulation, and over a much larger range by neutral density filters. The pulse width was set under program control by a three-channel l.e.d. controller board (designed by P. Lennie and built at the University of Sussex) in the computer interface (Cambridge Electronic Design, Ltd.) which was connected to three remote l.e.d. drivers. In each channel, one half of a bipartite field or a grating inside an adjustable aperture could be focused on the cat's retina. In this study, different combinations of the three channels were used at different times; stimulus strengths were referenced to the 'thresholds' (24 impulses in response to four $\frac{1}{2}$ sec flashes) observed after about 10 min of dark adaptation from a mesopic level.

Extrinsic noise was generated by modulating the width of pulses to the l.e.d.s according to a digital file of 2048 random numbers. The digital file was constructed to approximate Gaussian white noise, truncated at the extremes to three standard deviations. The Gaussian distribution was approximated by using the Digital Equipment Corporation Fortran random number generator, and transforming according to the method of Schwartz & Shaw (1975). (The file represents a portion of the 3000 number file used by Levine, 1982.) Each entry in the file determined the width of two consecutive pulses (200 Hz pulse repetition rate). The depth of modulation is reported as the peak-to-peak amplitude (± 3 standard deviations), expressed as a percentage of the mean.

To check that the Gaussian modulation would not induce any structure in the firing, an electronic simulation of an X-cell centre (Schweitzer-Tong, 1983) was used to generate test data. The same stimulus presented to the cats was presented to a UDT (Model 40X) optometer; the output of the optometer (filtered to exclude frequencies above 160 Hz) drove the voltage-to-frequency input of an Exact (Model 508) function generator, which sent pulses to the computer. 'Data' files generated in this way were analysed by the programs used to analyse the neural data. No significant structure could be demonstrated in these files.

Receptive field-centre size was first estimated by choosing the minimum diameter stimulus spot which produced the largest audible response to sinusoidal light modulation (1.5 Hz, 70% contrast). Then the stimulus aperture was adjusted to be slightly larger than the estimated receptive field-centre size. A bipartite field or a grating stimulus was placed within the aperture.

X/Y classification. A bipartite field generated by the two red channels was contrast-reversed at 1.5 or 2 Hz. The basis for classification was the presence of a null position for X cells (Enroth-Cugell & Robson, 1966) or the presence of a second harmonic Fourier component for Y cells that was, at maximum, more than twice the amplitude of the fundamental Fourier component (Hochstein & Shapley, 1976). Fourier components were calculated from average response histograms collected over 5 or 7 sec; test results were limited to cases where modulation of one half of the field led to peak-to-peak amplitudes of 10–20 impulses/sec. Cells which had large receptive field centres and whose responses sounded 'sluggish' were classified as W cells (Cleland & Levick, 1974; Stone & Fukada, 1974). All of the W cells for which linearity tests were performed proved linear.

Data collection. Data were collected in periods (gates) of 30 sec duration in most cases; 20.48 sec was used for experiments in which the light was modulated by Gaussian white noise. During each

gate, the time of occurrence of each spike was recorded to the nearest msec. A single 'observation' consisted of three gates that were usually consecutive. Gates at any given illumination level were collected until the mean rates in sequential gates were within 1 or 2 impulses/sec. Generally, gates in the dark were collected after at least 10 min of dark adaptation from a mesopic level; gates in light were collected after several minutes of adaptation to each new level.

Data analysis. Interspike interval histograms were computed with one msec resolution for the three 30 sec gates. For presentation, consecutive bins were added to give 2 msec resolution. Histograms were normalized so that the ordinate represents an estimate of the probability of obtaining intervals of each duration.

Two descriptors were calculated from the interval distributions: (1) the mean interval μ_1 and (2) the coefficient of variation, which was defined as the standard deviation of the intervals divided by the mean interval. The inverse of the mean interval is the mean rate.

There are several ways of assessing the statistical dependency of intervals. One indicator of structure is the normalized autocovariance, a time-locked function. This was derived by converting the autocorrelation function to autocovariance and dividing by the variance to normalize to the dimensionless units of correlation (this transformation is described by Levine, 1982). The autocorrelation function is an average response histogram in which each impulse is the origin for a histogram of all subsequent impulses, with all the histograms summed and divided by the total number of impulses. Its normalization is useful for comparing autocorrelations which are based on firing patterns with different mean rates.

To distinguish the observed normalized autocovariance from that predicted for a renewal process (random) with the same interval distribution, it may be compared to the normalized autoconvolution function. The normalized autoconvolution function is the autoconvolution (Yang & Chen, 1978; Levine, 1980) normalized by the same transformation that converts the autocorrelation into the normalized autocovariance (see Levine, 1983). The difference between the normalized autocovariance function and the corresponding normalized autoconvolution function represents the part of normalized autocovariance that is attributable to temporal ordering of the intervals.

Another way of demonstrating structure in the discharge is by deriving the serial correlogram (Kuffler *et al.* 1957; Perkel, Gerstein & Moore, 1967). Each serial correlation coefficient represents the product-moment correlation between an interval and the interval some specified number of intervals before it. A non-zero coefficient indicates that the duration of an interval is a function of the duration of the preceding interval (first-order coefficient), the interval before that (second order coefficient), and so forth.

For a quantitative examination of any possible changes in organization, only the serial correlogram will be considered. The serial correlogram and normalized autocovariance differ in that the serial correlogram reveals dependencies related to interval ordering, while the normalized autocovariance reveals time-locked dependencies; nevertheless, there is considerable overlap in what the two describe. The serial correlogram has two advantages for statistical comparisons: (1) it is not dependent upon the form of the interval distribution and (2) much of its information is contained in only a few numbers, the first few coefficients.

To demonstrate long-term organization in firing, a method recently devised by Levine (1980) was used. The log of the standard deviation of rate ($\sigma_{N/T}$) is plotted as a function of the log of the sample duration (T), and that function is compared to the predicted function:

$$\hat{\sigma}_{N/T} = \sigma_1 \mu_1^{-1/2} T^{-1/2} \quad (1)$$

where N is the total number of impulses, and μ_1 and σ_1 are the observed mean and standard deviation of the intervals, respectively. For each T computed, each data gate is divided into as many non-overlapping samples of length T as possible, and all samples are used in the estimation of the standard deviation of rate at that T .

The program that produced Figs. 3 and 6 first analysed the actual data (plotted as squares), and then calculated and drew the line corresponding to eqn. (1), which provides a standard for what would be expected for a renewal process with the observed interval distribution. In addition, the program shuffled the intervals and recalculated and plotted the standard deviation of rate *vs.* T (crosses). The shuffling was important in cases of low rate or coefficient of variation, where the assumptions leading to the predictions of eqn. (1) may fail.

Statistics. Correlations are reported as the Pearson product-moment correlation between pairs of variables. Correlations are considered to be significantly different from 0 when P is less than 0.02.

Since individual cells were often tested at more than one illumination level, N is larger than the number of cells.

When comparisons were made between values of a dependent variable under two different conditions (e.g. firing rate in strong light *vs.* firing rate in dim light), a paired comparison (Student's) t test was performed. When control conditions bracketed test conditions in time, the results of the control conditions were averaged. For comparisons of records using modulation with those using none, two t tests were run: the first included pairs of control and test conditions nearest in time; the second, termed the 'strong' test, used only the strongest modulations in order to maximize effects, and only those cases in which modulation noticeably affected the cell by raising the coefficient of variation were used. Generally, there was little difference between the results of the two t tests. Results reported are from the first test unless specified otherwise.

Sample. Data were recorded from thirty-nine retinal ganglion cells in ten different cats; in addition, data from ten units each recorded at a single photopic level were supplied by other investigators in this laboratory (Enroth-Cugell, Robson, Schweitzer-Tong & Watson, 1983). All of our units had receptive fields located within the central 20 deg of the visual field. After discarding four units because of strong rhythmic patterns in their maintained discharge, there were twenty-five on-X cells (none at photopic levels, thirteen recorded at more than one illumination), nine off-X cells (three at photopic levels, four recorded at more than one illumination), five on-Y cells (two at photopic levels, the remaining three recorded at more than one illumination), two off-Y cells (both at photopic levels), two on-W cells (one photopic), and two cells not properly classified (both at photopic levels). The units recorded at photopic levels were not included in the correlations or t tests, since the stimulus configuration (a uniform cathode ray tube screen at 400 cd m⁻²) was not comparable to those used for the other units. Modulation was used on nine cells; all were on-centre. Eight of the nine were X cells; one was a linear W cell.

RESULTS

Effect of steady illumination of the receptive field centre. Correlations of statistical parameters with illumination were based on pooled data from twenty-six units; the nine units devoted mainly to the study of effects of white noise (reported below) were not included. The correlation coefficients were separately computed for on-centre units ($N = 53$ observations from twenty units), off-centre units ($N = 29$ observations from six units), and all units pooled ($N = 82$ observations). The t tests were performed using only on-centre units, or all units pooled.

Mean firing rate was positively correlated with illumination for on-centre units ($r = +0.71$, $P < 0.0001$), and tended to be negatively correlated with illumination for off-centre units ($r = -0.35$). This effect was generally observable in each unit, although the functions were not uniformly monotonic. Rates in darkness were significantly lower than those in light for on-centre units ($t = -7.252$, 13 d.f.; $P < 0.0001$); there were insufficient data for a similar test of off-centre units. While there were also insufficient data for a statistical test of Y cells, a trend toward increased firing with increased illumination could also be seen in each of the five on-Y cells, indicating that this is not a feature unique to X cells.

The variability of the maintained discharge also was affected by the illumination. The coefficient of variation was negatively correlated with illumination ($r = -0.65$, $P < 0.0001$; t test: $t = 5.396$, 13 d.f., $P < 0.002$) for on-centre cells, and positively correlated with illumination for off-centre cells ($r = +0.54$, $P < 0.005$). In each case, its value declined with increasing mean rate (on-centre: $r = -0.63$, $P < 0.0001$; off-centre: $r = -0.46$, $P < 0.02$; all units pooled: $r = -0.57$, $P < 0.0001$). It is likely that the change in the coefficient of variation is a result of the change in mean rate with illumination, and not directly a result of illumination.

Since illumination affected the mean rate and the coefficient of variation, it inevitably caused changes in the normalized autocovariance functions. Two examples are given in Fig. 1 *A* and *B*, which show autocovariance functions from an off-X unit and an on-Y unit, each in darkness (continuous line) and in the presence of a steady mesopic light covering the receptive field centre (dashed line). The obvious differences between the functions in light and dark do not represent changes in the temporal organization of the firing, however, for they may be explained by the differences in the corresponding interval distributions, shown in Fig. 1 *C* and *D*. This can best be demonstrated by computing the differences between each normalized autocovariance function (in Fig. 1 *A* and *B*) and its corresponding normalized autoconvolution (from the interval distributions in Fig. 1 *C* and *D*). The resulting difference functions (shown in Fig. 1 *E* and *F*) represent the portion of the normalized autocovariance that is attributable to temporal ordering within the discharge. It is clear that there is virtually no structure in the discharge that cannot be derived from the interval distributions in each condition, and there is no difference between conditions.

Another way to demonstrate structure in the discharge is to derive the serial correlogram. The serial correlograms derived from the data used to generate Fig. 1 are shown in Fig. 2. As concluded from Fig. 1, there is little or no change in the dependence upon previous firing history; in fact, there is little such dependency to be changed.

The statistics of the first three serial coefficients for all our cells support the notion that there is little or no change in dependency with changes in illumination. All correlations of serial coefficients with level of illumination were negative, but none proved significant, whether considering on-centre cells, off-centre cells, or both types pooled. Similarly, no *t* test comparing values of any coefficient in dim *vs.* more intense illumination reached significance. (The largest absolute value of *t* observed was 2.297 with 18 d.f.)

It should be noted that the serial coefficients showed considerable variability. The standard deviations of each serial coefficient (all cells pooled) ranged from 2.08 to 555.7 times the absolute mean values of the coefficients. As a rule, the first three coefficients were similarly displaced in any observation; this may be inferred from the positive correlations between pairs of coefficients (all units: $r_{1,2} = +0.40$, $P < 0.0002$; $r_{2,3} = +0.29$, $P < 0.01$).

Although illumination seemed not to affect the relatively short-term correlations in the firing pattern, it is possible it affected the long-term structure. To test for this, we have compared plots of standard deviation of rate *vs.* sample duration in dim and more intense illumination. Such a comparison is shown in Fig. 3; Fig. 3 *A* is derived from three 30 sec gates of firing in the dark, Fig. 3 *B* is derived from the same unit firing in the presence of relatively strong steady retinal illumination. The first thing to note is that neither of these plots shows great deviation from the relationship to be expected in the absence of any structure. With the single exception of one unit that showed a striking difference between the observed and predicted standard deviations of rate (reminiscent of the patterns generally observed in goldfish: Levine, 1980), the observed standard deviations were minimally smaller than predicted. For some units, such as the one shown in Fig. 3, there was a tendency for the firing in the presence of higher illuminations to be more organized than that in the presence

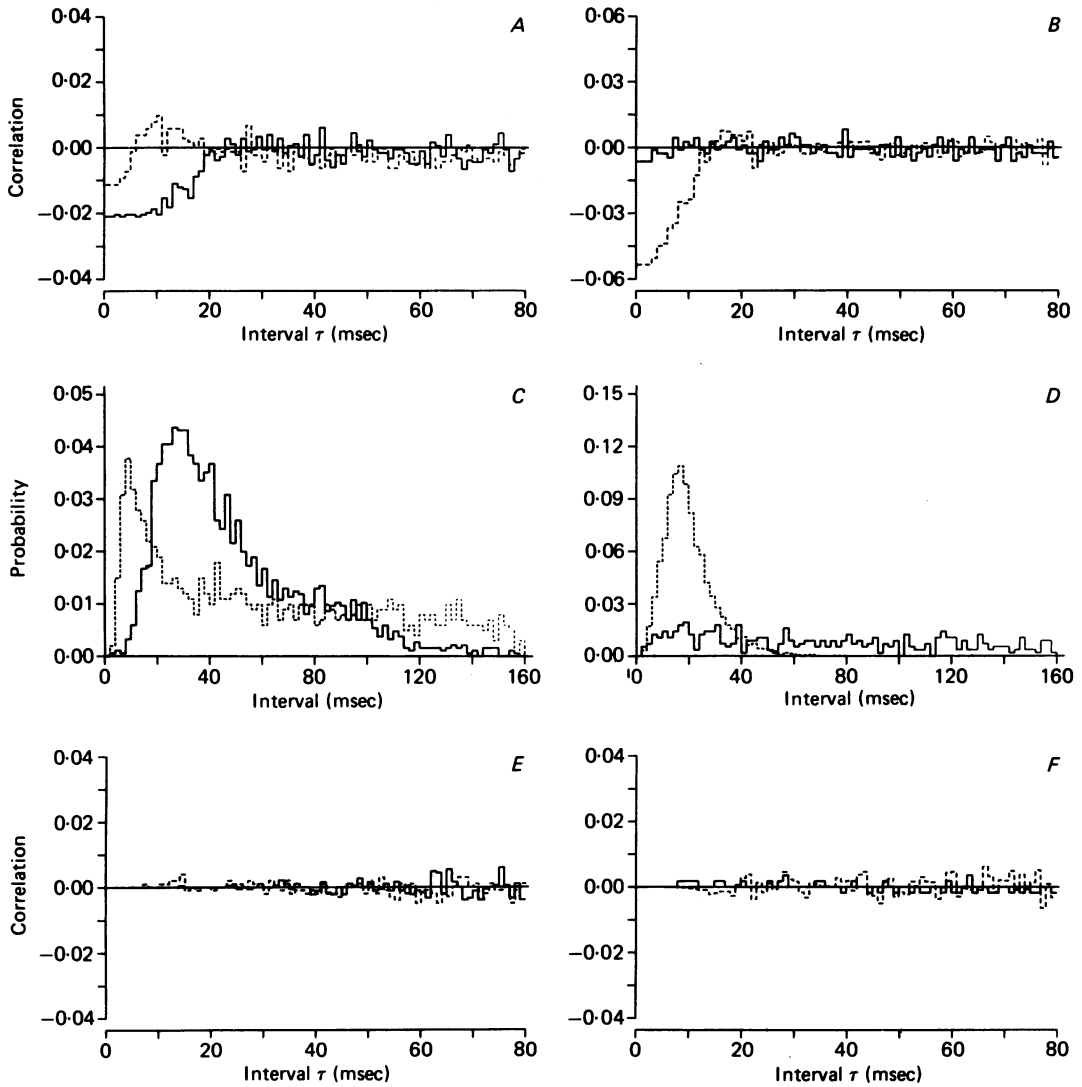

Fig. 1. Firing patterns of two retinal ganglion cells in darkness (continuous lines) and light (dashed lines). *A* and *B*, normalized autocovariance functions showing correlation as a function of lag interval, 1 msec bin width. *C* and *D*, interspike interval distributions, 2 msec bin width. *E* and *F*, differences between normalized autocovariance functions and normalized autoconvolution functions, 1 msec bin width. Each function is derived from three consecutive 30 sec gates; corresponding functions in *A*, *C*, *E*, and in *B*, *D*, *F* are from the same data. *A*, *C*, *E*, off-X unit 4/9; records in light in presence of 1 deg aperture with 1.31 cycles/deg sinusoidal gratings (red and green in counterphase), 2.0 log above threshold. Mean rate in dark = 20.5 impulses/sec, coefficient of variation = 0.59; mean rate in light = 11.2 impulses/sec, coefficient of variation = 0.89. *B*, *D*, *F*, on-Y unit 8/5; records in light in presence of 2 deg aperture with 9 cycles/deg square-wave gratings (red and green in counterphase), 4.1 log above threshold. Mean rate in dark = 6.2 impulses/sec, coefficient of variation = 0.96; mean rate in light = 50.6 impulses/sec, coefficient of variation = 0.50.

of lower illuminations; the unit shown in Fig. 3 represents one of the largest differences between dim and more intense illuminations.

In order to quantify the plots of standard deviation of rate *vs.* sample duration for statistical comparisons, straight lines were fitted to the observations of log standard deviation at short durations; examples may be seen as the dashed lines in Fig. 3. Two parameters may be derived from these lines: their slopes, and their displacements from the prediction of eqn. (1) (since there is no intrinsic origin, we arbitrarily chose to measure the displacement at 1.0 sec duration). In fact, these two parameters are strongly correlated, both for on-cells ($r = +0.78$, $P < 0.0001$) and off-cells ($r = +0.86$, $P < 0.0001$). The positive correlation implies that as slope becomes steeper (more different from -0.5 , the square-root relationship predicted by eqn. (1)), the displacement becomes more negative (standard deviation a smaller fraction of the predicted value).

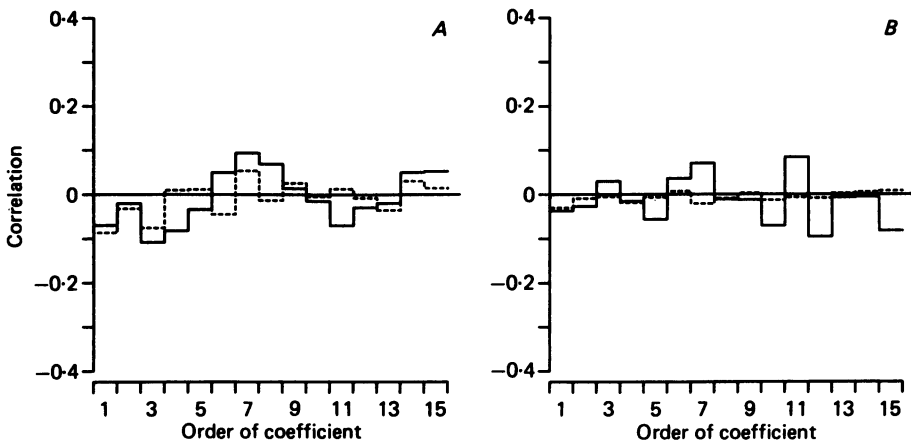

Fig. 2. Serial correlograms in darkness (continuous lines) and light (dashed lines). *A*, same data as Fig. 1 *A*, *C* and *E*. *B*, same data as Fig. 1 *B*, *D* and *F*.

The correlations of these parameters with illumination show that there does tend to be more organization at higher illuminations. When all units are pooled, slopes become more negative, i.e. steeper, with increasing illumination ($r = -0.33$, $P < 0.005$) as does displacement ($r = -0.42$, $P < 0.0001$). These correlations are also significant when only off-centre units are considered (slope: $r = -0.50$, $P < 0.001$; displacement: $r = -0.53$, $P < 0.005$), and are in the same directions when only on-centre units are considered (slope: $r = -0.25$; displacement: $r = -0.35$, $P < 0.01$). These relationships are apparently not secondary to the dependence of the mean rate or the coefficient of variation upon illumination, for none of the correlations between slope or displacement and rate or coefficient of variation are significantly different from zero, for either on- or off-centre units.

While the parameters of the plots of standard deviation of rate are significantly correlated with illumination, the relationship is not strong or consistent enough to yield a statistically significant difference on any *t* test. Table 1 presents the means and standard deviations of these parameters for the comparisons in the *t* tests.

Summary of the parameters of the maintained discharge. Since the parameters of the

maintained discharge (with the exception of the mean rate and the coefficient of variation) are minimally affected by changes in illumination, the data from all levels of illumination may be pooled to present a summary of these parameters. Table 2 presents the means (and standard deviations) of the values measured. This table includes the cells recorded at photopic levels; no differences were noted between the statistics of the units at photopic levels and those of the units included in the correlations reported above.

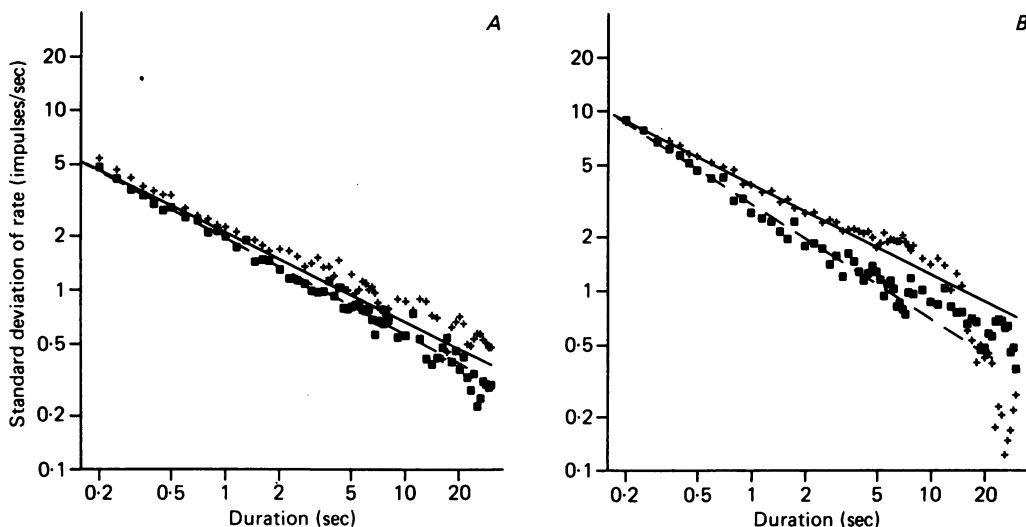

Fig. 3. Standard deviation of firing rate as a function of sample duration. Squares are derived from three consecutive 30 sec gates; crosses are derived from the same interval distribution after shuffling. Continuous lines are predictions of eqn. (1). On-Y unit 4/11. *A*, maintained discharge in the dark; mean rate = 3.6 impulses/sec, coefficient of variation = 1.08; dashed line slope = -0.54, displacement at 1 sec = -0.03 log. *B*, maintained discharge in the presence of a steady light: 4 deg aperture with 1.31 cycles/deg sinusoidal gratings (red and green in counterphase) 2.1 log above threshold; mean rate = 18.4 impulses/sec, coefficient of variation = 0.92; dashed line slope = -0.64, displacement at 1 sec = -0.11 log.

TABLE 1. Parameters of the plots of standard deviation of rate vs. duration comparing dim and more intense illumination. Means of eighteen paired observations, each of three 30 sec gates. Numbers in parentheses are standard deviations

	Dim	More intense
Slope of $\sigma_{N/T}$ line	-0.531 (0.056)	-0.569 (0.072)
Displacement of $\sigma_{N/T}$ line (log units)	-0.003 (0.057)	-0.046 (0.089)

The serial correlation coefficients (serial correlogram) are all very small, and, as pointed out above, there is considerable variability in these values. The fact that the means are nearly zero is consistent with the conclusion drawn from the individual differences between normalized autoconvolutions and normalized autocovariances that there is minimal short-term structure in the firing patterns. It should be noted, however, that the small negative first coefficient is significantly less than zero ($t = -3.144$, 91 d.f., $P < 0.005$).

TABLE 2. Parameters of the maintained firing of retinal ganglion cells in the cat. Means of observations, where each observation represents three gates of 30 sec. Numbers in parentheses are standard deviations

	On-centre, X cells	On-centre, Y cells	All on-centre	All off-centre	All cells
Number of units	17	5	23	11	36
Number of observations	39	17	57	35	92
Mean rate (spikes/sec)	34.58 (17.61)	30.28 (21.15)	33.66 (19.19)	26.37 (19.19)	30.88 (19.13)
Coefficient of variation	0.655 (0.343)	0.791 (0.288)	0.691 (0.330)	0.688 (0.206)	0.690 (0.288)
1st serial coefficient	-0.013 (0.093)	-0.035 (0.078)	-0.022 (0.089)	-0.032 (0.058)	-0.026 (0.079)
2nd serial coefficient	+0.003 (0.050)	-0.011 (0.048)	-0.006 (0.049)	-0.002 (0.041)	-0.001 (0.046)
3rd serial coefficient	-0.005 (0.041)	0.005 (0.043)	-0.005 (0.041)	-0.014 (0.056)	0.009 (0.047)
Slope of $\sigma_{N/T}$ line	-0.560 (0.079)	-0.561 (0.066)	-0.561 (0.074)	-0.540 (0.056)	-0.553 (0.068)
Displacement of $\sigma_{N/T}$ line (log units)	-0.037 (0.095)	-0.049 (0.054)	-0.041 (0.084)	-0.011 (0.057)	-0.030 (0.076)

Similarly, the means of the parameters of the standard deviation of rate *vs.* duration plots indicate only minimal deviation from a renewal process. The mean slopes are only slightly steeper than -0.5 and the mean displacements are very slightly less than zero; however, both of these small differences are significant: (displacement: $t = 3.742$, 91 d.f., $P < 0.0005$; slope: $t = 7.412$, 91 d.f., $P < 0.0001$). (Compare these values with those in Table 3, column 2.)

TABLE 3. Comparison of maintained firing in steady light with that in light modulated as Gaussian white noise. Conventions as in Table 1. Gate length = 20.48 sec. On-centre cells only

	No modulation	At least 50% modulation
Number of units	9	9
Number of observations	19	19
Mean rate (spikes/sec)	48.59 (16.60)	55.02 (13.68)
Coefficient of variation	0.440 (0.189)	0.823 (0.252)
1st serial coefficient	-0.074 (0.105)	+0.020 (0.063)
2nd serial coefficient	-0.019 (0.055)	-0.060 (0.057)
3rd serial coefficient	-0.027 (0.063)	-0.078 (0.051)
4th serial coefficient	-0.022 (0.034)	-0.064 (0.043)
Slope of $\sigma_{N/T}$ line	-0.576 (0.084)	-0.655 (0.102)
Displacement of $\sigma_{N/T}$ line (log units)	-0.084 (0.113)	-0.232 (0.113)

Modulation of the light. In order to compare the way the retina processes its intrinsic noise with the way it processes extrinsic signals, we have stimulated the receptive field centres of on-centre cells with white-noise modulation of the light. Comparisons in this section are between steady and modulated lights at the same mean illuminations. Mean data are summarized in Table 3.

Modulation of the light provides a source of variability in addition to the intrinsic variability of the maintained discharge; it is therefore not surprising that it generally increases the coefficient of variation. In some individual cases, modulation more than doubled the coefficient; on the average, it increased by about 87% when the modulation was greater than 50%. (The first column in Table 3 provides a set of comparison values in the absence of modulation. The high mesopic retinal illuminations used in the modulation experiment resulted in a considerably higher mean rate and lower coefficient of variation than was observed in the cells reported in Table 2.) The correlation of the coefficient of variation with depth of modulation was strongly positive ($r = +0.71$, $P < 0.0001$). Similarly, the paired *t* test comparisons showed significant elevation of the coefficient with increased modulation depth ($t = -6.624$, 11 d.f., $P < 0.0001$).

There was a tendency for the mean rate to increase with increased depth of modulation, indicating a non-linearity such as has been described for goldfish (Levine, 1982). However, this tendency was quite weak in the cat; the mean rate increased by only 13% while the coefficient of variation increased by 87%. In fact, the correlation of rate with depth of modulation is not significantly greater than zero ($r = +0.16$, $N = 13$), and the paired *t* test shows no significant change in rate ($t = -1.941$, 11 d.f.). Only the strong *t* test confirms a real rise in rate ($t = -3.426$, 7 d.f., $P < 0.02$).

Modulation of the light effected a considerable change in the organization of the

maintained discharge. An example is shown in Fig. 4*A*, in which the continuous line is the normalized autocovariance from an on-X cell firing in steady light, while the dashed line is the normalized autocovariance from the same unit when the identical light was modulated at 100%. That this difference is not wholly attributable to changes in the interval distribution may be seen in Fig. 4*B*, which shows the differences between the normalized autocovariances and normalized autoconvolutions for the same data. The firing in the absence of modulation is not noticeably different from a renewal process, but obvious structure is evident in the presence of modulation. Similar results were obtained from eight of the nine cells tested.

Organization of the discharge in the presence of modulation may be discerned in the serial correlograms as well. Fig. 5 presents serial correlograms derived from the

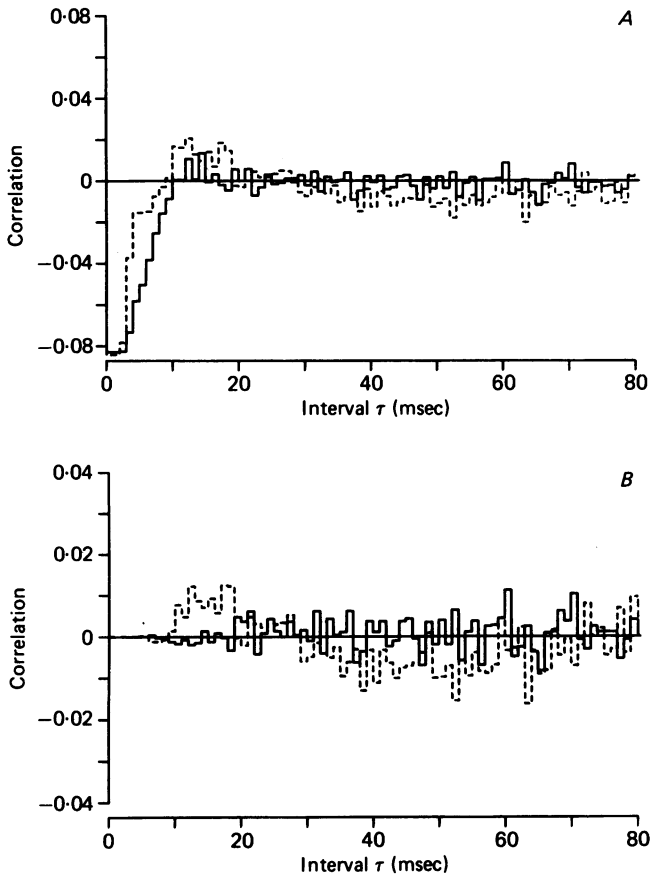

Fig. 4. Firing patterns in the presence of a steady light (continuous line) and the same mean illumination modulated at 100% contrast by Gaussian white noise (dashed line). Each function is derived from three consecutive 20.48 sec gates. On-X unit 12/10; 2 deg aperture with red stimulus in half of bipartite field, 4.28 log above threshold. Mean rate in steady light = 76.4 impulses/sec, coefficient of variation = 0.44; mean rate in modulated light = 77.5 impulses/sec, coefficient of variation = 0.78. *A*, normalized autocovariance functions. *B*, differences between normalized autocovariance functions and normalized autoconvolution functions, 1 msec bin width.

data of Fig. 4. The first coefficient was rendered more positive, while the next few were made more negative by the modulation. The pattern in the steady light was barely different from a renewal process, while that in the presence of modulation showed clear evidence of structure.

Statistics of the first four serial coefficients bear out the above observations. The first coefficient is positively correlated with depth of modulation ($r = +0.38$, $P < 0.02$), while the second, third and fourth are negatively correlated ($r_2 = -0.34$, $P < 0.05$; $r_3 = -0.41$, $P < 0.01$; $r_4 = -0.40$, $P < 0.01$). The t test comparisons showed a significant difference in the second and third coefficients ($t_2 = 2.627$, 11 d.f., $P < 0.02$; $t_3 = 5.068$, 11 d.f., $P < 0.0005$); the strong tests uniformly showed greater significance, with $P < 0.01$ for each of the first four coefficients.

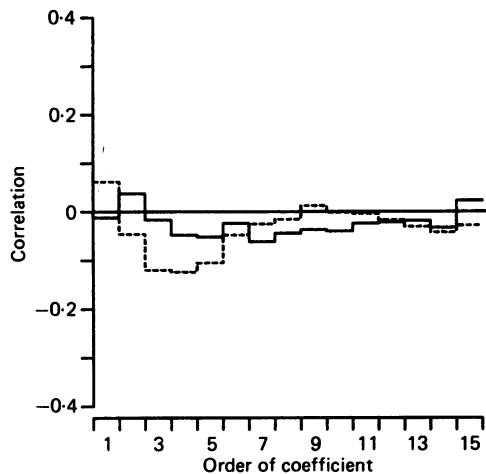

Fig. 5. Serial correlograms derived from the same data as in Fig. 4.

Plots of standard deviation of rate *vs.* duration also reveal a strong organization of the firing in response to randomly modulated light. Fig. 6 shows a series of these plots for a single unit at one mean retinal illumination. Fig. 6*A* presents the pattern derived from three 20.48 sec gates with no modulation, Fig. 6*B* with 50% modulation, Fig. 6*C* with 100% modulation. Clearly, as the modulation is increased, the slope of the line fit to the observed standard deviations of rate becomes steeper, and the displacement of the line from the prediction of eqn. (1) becomes greater. The pattern in Fig. 6*C* is similar to that observed in goldfish, either with or without modulation of the light (Levine, 1980, 1982). Similar changes were observed in all units studied, except for one that exhibited strongly oscillatory behaviour in the presence of Gaussian noise.

Statistics of the parameters of lines fit to the observed standard deviations further support the notion that presentation of random (renewal process) noise to the receptors leads to a pattern that looks less like a renewal process than the firing in the absence of modulation. The correlation of the slope with depth of modulation is negative ($r = -0.56$, $P < 0.0001$), implying steeper slope with greater modulation. Similarly, there is a negative correlation between displacement and depth of

modulation ($r = -0.41$, $P < 0.01$), implying that the observed standard deviation of rate is lower relative to the prediction of eqn. (1) when the light is modulated than when it is steady. Paired t test comparisons of the steady condition to the modulated confirm a difference between conditions (slope: $t = 3.593$, 11 d.f., $P < 0.005$; displacement: $t = 2.265$, 11 d.f., $P < 0.05$; strong test, $t = 3.216$, 7 d.f., $P < 0.02$).

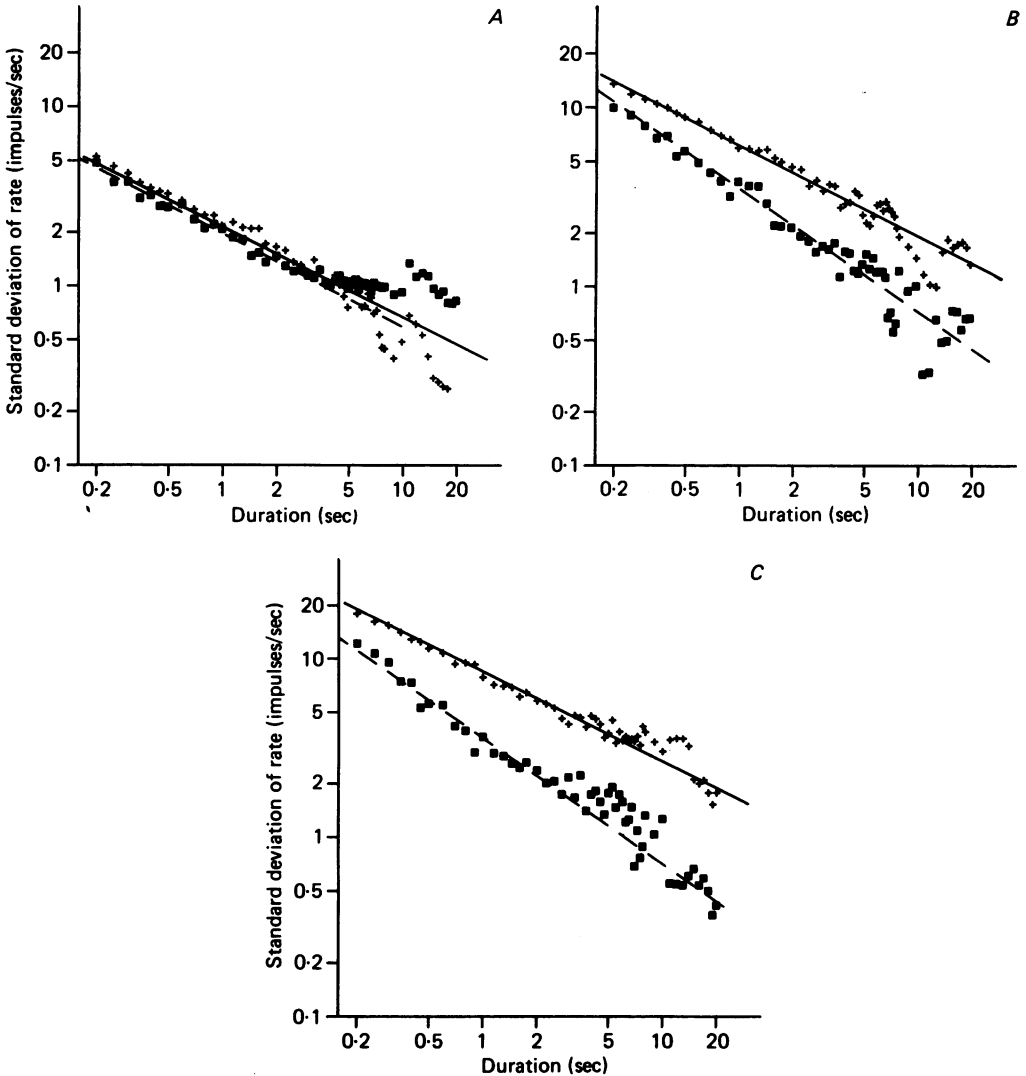

Fig. 6. Standard deviation of rate vs. sample durations; same mean illuminations with different contrasts of modulation by Gaussian white noise. (Same conventions as Fig. 3.) On-X unit 11/6; 1 deg aperture with red/green bipartite field 4.65 log above threshold. *A*, steady illumination; mean rate = 36.2 impulses/sec, coefficient of variation = 0.35; slope of dashed line = -0.52 , displacement at 1 sec = -0.04 log. *B*, 50% modulation; mean rate = 45.5 impulses/sec, coefficient of variation = 0.92; slope of dashed line = -0.68 , displacement at 1 sec = -0.24 log. *C*, 100% modulation; mean rate = 49.5 impulses/sec, coefficient of variation = 1.20; slope of dashed line = -0.71 , displacement at 1 sec = -0.37 log.

DISCUSSION

Comparison to previous work. Our observation that the coefficient of variation decreases at higher rates of firing is consistent with Barlow & Levick's (1969) observations for on-centre neurones, and with Rodieck's (1967) data. Our interval distributions are quite similar to those reported by Barlow & Levick (1969) and by Sanderson, Kozak & Calvert (1973). Our finding that on-centre cells increase their mean rates at higher illuminations while off-centre cells decrease their mean rates is also in general agreement with Barlow & Levick's (1969) report, but our changes in rate were more consistent than theirs. The greater consistency we observed could be due to the limited range of illuminations we used.

The temporal patterning of the firing which is revealed in the normalized autocovariances is comparable to the patterning in Rodieck's (1967) autocorrelograms (which differ only in the scaling of the ordinate). The autoconvolutions presented in Rodieck's paper are also similar to their corresponding autocorrelograms, but since the autocorrelograms and autoconvolutions were not shown on the same axes, we do not know whether the differences would be as negligible as the differences between normalized autocovariance and normalized autoconvolution that we observed.

Our statistical analyses of dependency were based upon the serial correlograms and the plots of standard deviation of rate *vs.* sample duration. There are no measures comparable to the latter in other papers, but Kuffler *et al.* (1957), Rodieck (1967), and Sato *et al.* (1976) present serial correlograms that differ from ours. The principal difference lies in the first coefficient; we report a quite small negative value (-0.026), while others have reported significantly more negative values (Kuffler *et al.*: -0.173 ; Rodieck: -0.060 ; Sato *et al.*: X cells: -0.121 , Y cells: -0.084).

It is not clear why our data showed less dependency than those of others. Since the mean value of the first serial coefficient is not dramatically different across cell types in our preparation (see Table 2), it is unlikely that we sampled a different population of ganglion cells. It is possible that differences in anaesthesia were responsible; the others used decerebration, nitrous oxide, barbiturates, or combinations of two of these, whereas we used urethane.

While the mean values of our first serial coefficients differ, we agree with Rodieck (1967) on a significant point: the serial correlogram was not affected by ambient steady illumination. It thus seems that the lack of effect of illumination in our results is not simply explicable by our rather small coefficients.

A model for intrinsic noise in the cat's maintained discharge. How can we account for the statistical dependency we have observed? A simple way to achieve a negative first serial coefficient is by alternating long and short intervals (closely spaced pairs), which may be due to a hyperexcitability of the ganglion cell membrane (see Raymond, 1979). In the extreme, this might be recognizable as a burstiness, and probably be considered a pathological symptom.

On the other hand, a negative first coefficient can indicate that random noise has been operated on by a high-pass filter. A high-pass filter is also implicated by the observation that the standard deviation of rate (for long sample durations) is smaller than would be expected for a renewal process (Levine, 1980). Since we observed a strong correlation ($r = +0.48$, $P < 0.0001$) between the first serial coefficient (also the

second and third) and the displacement of the line representing standard deviation of rate *vs.* sample duration, it is likely that the negative coefficient is due to high-pass filtering. (Note that this correlation is based only on data collected in the absence of modulation of the light.)

Although the maintained discharge of ganglion cells shows evidence of high-pass filtering, the filtering must be weak for the measures indicating it are small. This is in contrast to the responses to Gaussian modulation of light, where increased negative displacement and more negative slope of the line relating standard deviation of rate to sample duration indicate greater high-pass filtering. The more positive first serial coefficient in the presence of Gaussian modulation indicates that low-pass filtering must also be present. Thus, extrinsic noise is processed by a band-pass filter.

Band-pass filtering of extrinsic noise was also implicated for goldfish retinal ganglion cells (Levine, 1982). However, goldfish ganglion cells also showed evidence of strong high-pass filtering of intrinsic noise in the absence of Gaussian modulation of light. The most parsimonious model for goldfish ganglion cells is one in which the band-pass properties of the retinal network are achieved by the serial application of a low-pass and a high-pass filter; the intrinsic noise is injected between these filters, so that it is processed by the high-pass filter only (Levine, 1982).

There are at least two simple modifications of the goldfish model that can accommodate the data from the cat, in which the organization is attenuated in the absence of modulation. One possibility (Fig. 7A) is to assume that the filters in the visual processing path are distributed, rather than being two discrete (or lumpable) filters. In that case, the 'high-pass filter' could actually be a cascade of high-pass filters. Then the difference between the cat and goldfish could be that for the cat the intrinsic noise is injected later in the cascade, so it is less filtered. It should also be noted that the over-all parameters of the filtering network must be somewhat different from those in the fish to account for the different appearances of the serial correlograms in the presence of Gaussian modulation of the light, and that the extreme non-linearity in the retinal processing network of fish (i.e. a marked increase of mean rate in the presence of modulation) is absent or weak in the cat.

This model has some similarities to one presented by Shapley & Victor (1981) for the contrast gain control mechanism in cat retina. In their model, the visual signal is conditioned by a cascade of low-pass filters, followed by a single-stage high-pass filter whose parameters depend upon the contrast. However, the high-pass filter in our model would also have to be a cascade, with the intrinsic noise injected before the last stage. Then the intrinsic noise would be only slightly filtered, and the increased high-pass filtering we observe at higher illuminations (which produced higher contrasts) would be consistent with the increased product of gain and band width they observed for higher contrasts.

A second way to account for our data from the cat is to assume that there are two sources of intrinsic noise in the maintained discharge: one ('distal source') enters the network early enough to enjoy the high-pass filtering imposed upon visual signals; the second ('proximal source') provides random variability at the end of the retinal processing network (see Fig. 7B). The distal source could be analogous to the noise source in fish, entering before the high-pass filter. The proximal source is either absent or much less significant in fish. The distal source provides the structured discharge

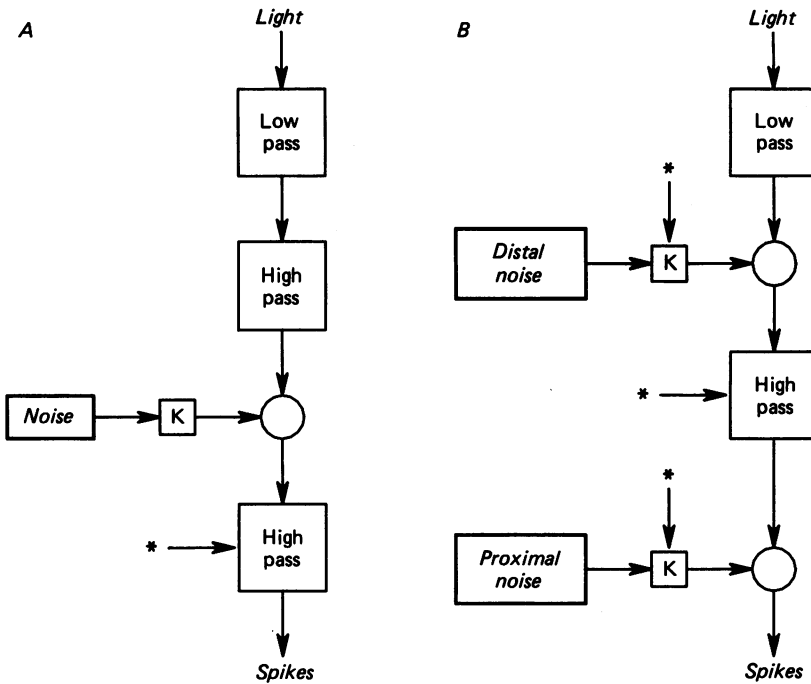

Fig. 7. Two models that incorporate our findings. Photic signals enter at the top; intrinsic noise is generated in the rectangles to the left. Circles represent the combination of signals, not necessarily linearly. Asterisks represent points at which gain or filter properties might be altered by mean illumination. *A*, single noise source injected within cascade of filters. *B*, distal noise precedes all high-pass filtering, proximal noise injected after all filtering.

noted for fish; the proximal source provides a random component that dilutes the structure in the cat, sometimes obscuring it entirely. The particular pattern observed would depend on the relative variability provided by these sources.

We also considered the possibility that the high-pass filter might fail to be patent in the maintained discharge simply because it has a dead zone, and the greater variability produced by our extrinsic modulation was required to exceed that non-linearity. Since filtering is not entirely absent in the maintained discharge, one might then expect the more variable units to show greater filtering. To test this hypothesis, we correlated the parameters considered in this paper with the variability of the maintained discharge, but found no significant relationships. In fact, the tendency was for instances of greater variability to show less high-pass filtering. Thus, we cannot explain the minimal filtering of the maintained discharge by hypothesizing that the variability was too low for the filter to express itself.

The origin of retinal variability. It is hard to specify the most distal anatomical level at which noise might enter the processing network. Barlow & Levick (1969) have suggested that the variability of the maintained discharge comes from the receptors, that it is a Poisson process resulting from the absorption of photons (or spontaneous pigment isomerizations in the dark). Our evidence is inconsistent with this hypothesis, even for the distal source of the model in Fig. 7*B*. The principal reason for this assertion is that there is a qualitative difference between the serial correlograms observed in steady light and those observed in the presence of random modulation of the light at the same mean illumination. Any signal triggered by isomerization must

travel the same retinal pathway, whether the variability in that signal is due to the variability of photon absorption, spontaneous isomerizations, or our randomly induced variations in the mean rate of quantum arrival. A negative first coefficient in steady light (or dark) would be inconsistent with a positive first coefficient in the presence of modulation.

If the absorption of photons were the source of much of the variability of the maintained discharge, one would expect this variability to decline when the mean illumination is increased (so that relative variability becomes much smaller). In fact, the coefficient of variation of receptors has been reported to decline as the $5/2$ power of illumination (Zeevi & Mangoubi, 1978), or at least more rapidly than the hyperpolarization (Lamb & Simon, 1977). Thus, the coefficient of variation that we observed in ganglion cells should be negatively correlated with illumination; this is what is observed for on-centre cells, but the opposite occurs for off-centre cells. Moreover, if the distal source were due to isomerizations, the relative variability of that source should decrease with increased illumination, and thus the organization should also decrease, which it does not. Of course, there could also be some even more powerful effects upon the random proximal source at the end of the processing network, or a change in the filtering network, such as the change in product of gain and band width described by Shapley & Victor (1981).

While isomerization may not be the source of the most distal variability, a receptor locus cannot be excluded. The only restriction is that there be an opportunity for low-pass filtering between the absorption of photons and the point at which the distal noise is introduced into the processing hierarchy. Such low-pass filtering is indeed found within photoreceptors (Baylor, Hodgkin & Lamb, 1974; Baron & Boynton, 1975; Toyoda & Coles, 1975; Schwartz, 1977). A noise source in the receptors could follow this filtering, even though receptor noise has generally been attributed to light-sensitive events (Lamb & Simon, 1976, 1977), or at least localized in the outer segments (Baylor, Matthews & Yau, 1980). Given the expected decline in receptor noise with illumination and the large number of receptors serving each ganglion cell, it seems more likely that the noise source is proximal to the low-pass filtering of the receptor-bipolar synapse (Ashmore & Copenhagen, 1980).

Just as the most distal point can be excluded as the locus for the injection of noise (or distal noise), the possibility that the organization is due to the ganglion cell spike-generating mechanism itself can also be rejected. Since a long-term process such as variation of nervous excitability following activity (Raymond, 1979) would have to effect the intrinsic variability as much as the variability induced by modulation, it cannot account for the organization reported here.

We would like to thank Dr C. Enroth-Cugell for her encouragement and support. We are also grateful to Drs J. Troy, D. Schweitzer-Tong and C. Enroth-Cugell for their comments on this manuscript.

This work was supported by N.I.H. grants R01EY00206 and F32EY05297.

REFERENCES

- ASHMORE, J. F. & COPENHAGEN, D. R. (1980). Different postsynaptic events in two types of retinal bipolar cell. *Nature, Lond.* **288**, 84–86.
- BARLOW, H. B. & LEVICK, W. R. (1969). Changes in the maintained discharge with adaptation level in the cat retina. *J. Physiol.* **202**, 699–718.
- BARLOW, H. B., LEVICK, W. R. & YOON, M. (1971). Responses to single quanta of light in retinal ganglion cells of the cat. *Vision Res. Suppl.* **3**, 87–101.
- BARON, W. S. & BOYNTON, R. M. (1975). Response of primate cones to sinusoidally flickering homochromatic stimuli. *J. Physiol.* **246**, 311–331.
- BAYLOR, D. A., HODGKIN, A. L. & LAMB, T. D. (1974). Reconstruction of the electrical responses of turtle cones to flashes and steps of light. *J. Physiol.* **242**, 759–791.
- BAYLOR, D. A., MATTHEWS, G. & YAU, K.-W. (1980). Two components of electrical dark noise in toad retinal rod outer segments. *J. Physiol.* **309**, 591–621.
- CLELAND, B. G. & LEVICK, W. R. (1974). Brisk and sluggish concentrically organized cells in the cat's retina. *J. Physiol.* **240**, 421–456.
- ENROTH-CUGELL, C., GOLDSTICK, T. K. & LINSSENMEIER, R. A. (1980). The contrast sensitivity of retinal ganglion cells at reduced oxygen tensions. *J. Physiol.* **304**, 59–81.
- ENROTH-CUGELL, C., HERTZ, B. G. & LENNIE, P. (1977). Cone signals in the cat's retina. *J. Physiol.* **269**, 273–296.
- ENROTH-CUGELL, C. & ROBSON, J. G. (1966). The contrast sensitivity of retinal ganglion cells of the cat. *J. Physiol.* **187**, 517–552.
- ENROTH-CUGELL, C., ROBSON, J. G., SCHWEITZER-TONG, D. E., & WATSON, A. B. (1983). Spatio-temporal interactions in cat retinal ganglion cells showing linear spatial summation. *J. Physiol.* (in the Press).
- HOCHSTEIN, S. & SHAPLEY, R. M. (1976). Quantitative analysis of retinal ganglion cell classifications. *J. Physiol.* **262**, 237–264.
- KINSTON, W. J., VADAS, M. A. & BISHOP, P. O. (1969). Multiple projection of the visual field to the medial portion of the dorsal lateral geniculate nucleus and the adjacent nuclei of the cat. *J. comp. Neurol.* **136**, 295–316.
- KUFFLER, S. W., FITZHUGH, R. & BARLOW, H. B. (1957). Maintained activity in the cat's retina in light and darkness. *J. gen. Physiol.* **40**, 295–316.
- LAMB, T. D. & SIMON, E. J. (1976). The relation between intercellular coupling and electrical noise in turtle photoreceptors. *J. Physiol.* **263**, 257–286.
- LAMB, T. D. & SIMON, E. J. (1977). Analysis of electrical noise in turtle cones. *J. Physiol.* **272**, 435–468.
- LEVICK, W. R. (1972). Another tungsten microelectrode. *Med & Biol. Engng* **10**, 510–515.
- LEVINE, M. W. (1980). Firing rates of a retinal neuron are not predictable from interspike interval statistics. *Biophys. J.* **30**, 9–20.
- LEVINE, M. W. (1982). Retinal processing of intrinsic and extrinsic noise. *J. Neurophysiol.* **48**, 992–1010.
- LEVINE, M. W. & FRISHMAN, L. F. (1981). Interactions of rod and cone inputs to cat retinal ganglion cells. *Invest. Ophthalm. & vis. Science Suppl.* **20**, 14.
- NYGAARD, R. W. & FRUMKES, T. E. (1982). Calibration of the retinal illuminance provided by Maxwellian views. *Vision Res.* **22**, 433–434.
- PERKEL, D. H., GERSTEIN, G. L. & MOORE, G. P. (1967). Neuronal spike trains and stochastic point processes. I. The single spike train. *Biophys. J.* **7**, 391–418.
- RAYMOND, S. A. (1979). Effects of nerve impulses on threshold of frog sciatic nerve fibres. *J. Physiol.* **290**, 273–303.
- RODIECK, R. W. (1967). Maintained activity of cat retinal ganglion cells. *J. Neurophysiol.* **30**, 1043–1071.
- SANDERSON, A. C., KOZAK, W. M. & CALVERT, T. W. (1973). Distribution coding in the visual pathway. *Biophys. J.* **13**, 218–244.
- SATO, T., YAMAMOTO, M. & NAKAHAMA, H. (1976). Variability of interspike intervals of cat's on-center optic tract fibers activated by steady light spot: a comparative study on X and Y fibers. *Exp. Brain Res.* **24**, 285–293.
- SCHWARTZ, E. A. (1977). Voltage noise observed in rods of the turtle retina. *J. Physiol.* **272**, 217–246.
- SCHWARTZ, M. & SHAW, L. (1975). *Signal Processing*, pp. 104–109. New York: McGraw Hill.

- SCHWEITZER-TONG, D. E. (1983). The photoneuromime: an artificial visual neuron for dynamic testing of computer-controlled experiments. *Behav. Res. Meth. & Instrum.* (in the Press).
- SHAPLEY, R. M. & VICTOR, J. D. (1981). How the contrast gain control modifies the frequency responses of cat retinal ganglion cells. *J. Physiol.* **318**, 161-179.
- STONE, J. & FUKADA, Y. T. (1974). Properties of cat retinal ganglion cells: A comparison of W-cells with X- and Y-cells. *J. Neurophysiol.* **37**, 722-748.
- TOYODA, J. I. & COLES, J. A. (1975). Rod response to sinusoidally flickering light. *Vision Res.* **15**, 981-983.
- YANG, G. L. & CHEN, T. C. (1978). On statistical methods in neuronal spike-train analysis. *Math. Biosci.* **38**, 1-34.
- ZEEVI, Y. Y. & MANGOUBI, S. S. (1978). Noise suppression in photoreceptors and its relevance to incremental intensity thresholds. *J. opt. Soc. Am.* **68**, 1772-1776.