

Inheritance of Duane's syndrome

T. H. KIRKHAM*

The Royal Infirmary, Sheffield

The retraction syndrome described by Duane in 1905 comprises complete or less often partial absence of abduction, with retraction of the affected eye into the orbit and narrowing of the palpebral fissure on adduction. There is often an upshoot or downshoot of the globe on adduction. On attempted abduction there is usually slight protrusion of the globe with widening of the palpebral aperture.

A familial incidence has been noted in about 10 per cent. of the cases reported in the literature (Duke-Elder, 1964), although in most reports no adequate family investigation appears to have been made.

Familial cases of Duane's syndrome have been reported by many authors during the past 100 years.†

Also, evidence for "formes frustes" of Duane's syndrome in other family members in the form of pareses of oculomotor muscles other than the lateral rectus or of slight narrowing of the palpebral fissure on adduction, has been reported by François and de Vos (1958) and by Orłowski, Krych, and Michniowska-Leonowicz (1961).

Most of the above observations have been confined to single sibships, or to two and occasionally three generations. Duane's syndrome has occurred as an isolated phenomenon in each of these reports, apart from those of Mein (1968) and Kirkham (1969a) where perceptive deafness was a feature, and Waardenburg (1963) where the Klippel-Feil anomaly was seen in a girl and in her paternal aunt.

The Klippel-Feil anomaly consists of a variety of bony deformities of the cervical spine, usually involving fusion, which appears clinically as a short neck with a limited range of movements of the head and neck and a low posterior hairline.

Present investigations

This paper attempts to elucidate the nature of the genetic factors responsible for the inheritance of Duane's syndrome and its relationship to perceptive deafness and to the Klippel-Feil anomaly.

Between the years 1949 and 1968, a total of 149,000 new patients with strabismus was seen in the Orthoptic Clinics of the United Sheffield Hospitals; of these only 126 (0.84 per cent.) had Duane's syndrome. This accords well with the experience of White and Brown (1939), who found that twelve (1.1 per cent.) of their 1,062 patients with strabismus had Duane's syndrome.

Received for publication September 15, 1969

* Present address (for reprints): The Nuffield Laboratory of Ophthalmology, Walton Street, Oxford.

† Harlan, 1885; Gunsburg, 1889; Türk, 1896, 1899; Wolff, 1900; Varese, 1901; Best, 1903; Kraus, 1905; Endelman, 1911; Peters, 1921; Waardenburg, 1923, 1932, 1953, 1963; Gifford, 1926; Zentmayer, 1935; Lodberg, 1937; Malbrán, 1949; Schlossman and Priestley, 1952; Böhringer, 1952; Weekers and Daenen, 1955; Gundersen and Zeavin, 1956; Gedda and Magistretti, 1956; François and De Vos, 1958; Bekenn, 1961; Dias Alves, 1961; Pintucci and Di Tizio, 1961; Goldfarb and Gannon, 1964; Kanbayashi, Ichikawa, Tani, Maki, Taji, and Kaino, 1967; Mein, 1968; Kirkham, 1969a.

The clinical picture in this condition is known to be variable. Lyle and Wybar (1967) subdivided such patients into three groups according to the degree of involvement of abduction or adduction; for the present study this was not considered important and would have been difficult in view of the many variations seen.

The 126 patients in this series comprised 82 females (65 per cent.) and 44 males (35 per cent.). In the male patients, the syndrome affected the right side in eight, and the left side in twenty-six, and was bilateral in ten. In the female patients the right side was involved in twenty, and left side in fifty, and both sides in twelve. Thus, in all, the right side was involved in 22 per cent., the left side in 60 per cent., and both sides in 18 per cent. of cases

Detailed family histories were obtained from 94 of these patients who were traced and re-examined. Wherever the possibility of strabismus or deafness existed in a relative, ophthalmic or audiological examinations were arranged. In many of the families there were cases of concomitant strabismus and otosclerosis, but the investigations of others revealed patients with Duane's syndrome or perceptive deafness.

A further eighteen patients replied to a questionnaire, denying the presence of deafness or cervical spine anomalies, and of squint, deafness, or cervical spine anomalies in relatives. The clinical records of the remaining fourteen patients made no reference to the presence (or absence) of deafness or spinal anomalies.

Of the 112 patients for whom clinical information was complete, twelve had perceptive deafness and five had the Klippel-Feil anomaly. Only two patients demonstrated the full triad of Klippel-Feil anomaly, Duane's syndrome, and perceptive deafness.

Figures 1, 2, and 3 show the pedigrees of the index patients who were themselves deaf or had the Klippel-Feil anomaly, or in which other members of the family were affected by Duane's syndrome or perceptive deafness. In one family a possible instance of the Klippel-Feil anomaly occurred in a female infant who died soon after birth; no *post mortem* examination was performed. The pedigree of a family affected through five generations with perceptive deafness in which two patients had Duane's syndrome has been reported elsewhere (Kirkham 1969a) and is not included here.

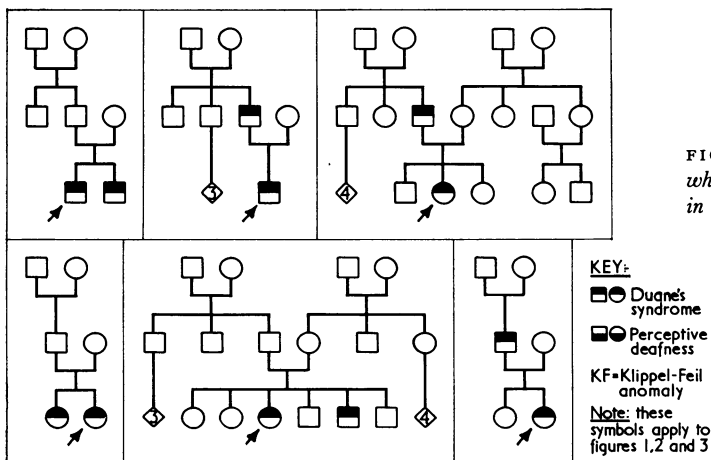

FIG. 1 Pedigrees of families in which Duane's syndrome occurred in isolation

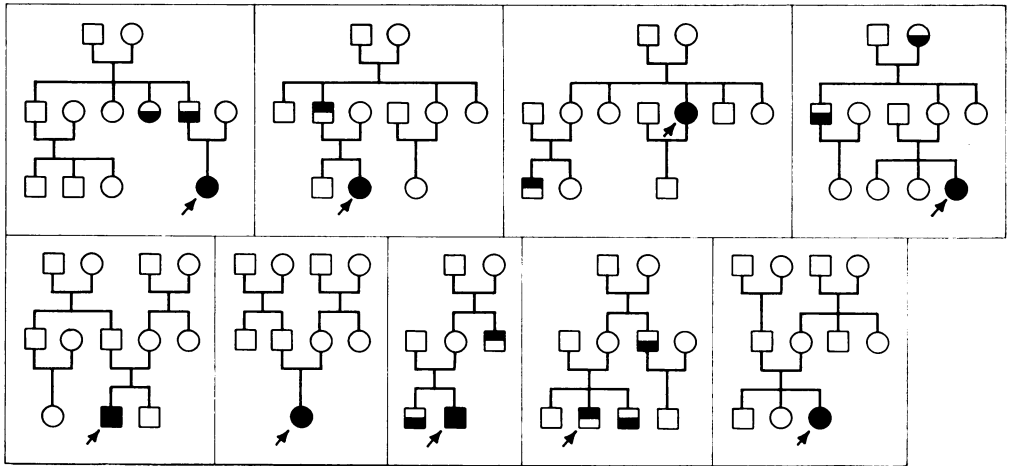

FIG. 2 *Pedigrees of families in which Duane's syndrome occurred with perceptible deafness*

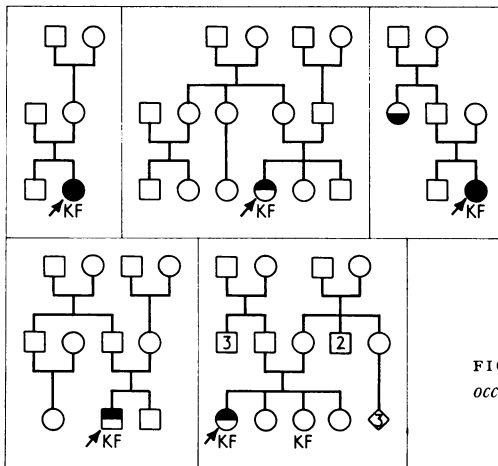

FIG. 3 *Pedigrees of families in which Duane's syndrome occurred in association with the Klippel-Feil anomaly*

Discussion

Isolated instances of Duane's syndrome with deafness or the Klippel-Feil anomaly are not unknown. Bielschowsky (1939) described a congenitally deaf-mute girl with bilateral Duane's syndrome, and Mein (1968) mentioned two cases of deafness in her series of 77 patients with Duane's syndrome. In a review of visual defects in deaf children, Stockwell (1952) noted that one female showed absence of the lateral rectus muscles, possibly a case of Duane's syndrome.

Single cases of Duane's syndrome associated with the Klippel-Feil anomaly have been reported by Mau (1924), Magnus (1944), Casellato and Meucci (1957), and Mein (1968). The male patient described by Baumann (1932) who could not turn either eye outwards possibly belongs to this category, as do the female patient of Thomson (1937) with an lateral rectus palsy and the girl described by Latto (1942) with the Klippel-Feil anomaly whose lateral ocular movements were said to be limited.

The association of profound childhood deafness with the Klippel-Feil anomaly is well established; Whetnall and Fry (1964) described three female patients, one of whom had defective vision (? Duane's syndrome). Fraser (1964) saw nineteen cases of the Klippel-

Feil anomaly in profoundly deaf children, and other similar cases were reported by Mitchell (1934), Bizarro (1938), Schwarze (1941), Erskine (1946), Bardadin and Siedlanowska (1955), Witzel (1958), and Cohney (1963).

A girl with the Klippel-Feil anomaly, Duane's syndrome, and congenital deafness was reported by Wildervanck (1952) and the same triad of signs in two other girls was documented by Waardenburg (1953). The syndrome was given the title cervico-oculo-facial dysmorphism by Franceschetti and Klein (1954) and by Pintucci and di Tizio (1961) who reported further cases. Wildervanck (1960) gave a detailed report of a similar girl who had, in addition, an epibulbar dermoid, and described further incomplete cases of the syndrome which he preferred to call the cervico-oculo-acusticus syndrome. The name "Wildervanck's syndrome" was suggested by Everberg, Ratjen, and Sorensen (1963) who described radiological abnormalities of the inner ear in a male patient with the syndrome. Further examples of the full syndrome have been described by Bintliff (1965), Wildervanck, Hoeksema, and Penning (1966), Franceschetti, Klein, Brocher, and Ammann (1966), Fraser and MacGillivray (1968), McLay and Maran (1969), and Kirkham (1969b).

It is obvious from this review of the literature that a definite relationship exists between some cases of Duane's syndrome, perceptive deafness, and the Klippel-Feil anomaly.

Instances of deafness, often congenital, were discovered in relatives of the patients described by Bielschowsky (1939), Franceschetti and Klein (1954), Wildervanck (1960), Wildervanck and others (1966), Franceschetti and others (1966), and Kirkham (1969a). In addition, the brother of the patient described by Franceschetti and others (1966) was said to have had similar deformities of the neck and mouth which resulted in neonatal death. One relative of a patient described by Fraser and MacGillivray (1968) had a short neck and another a speech defect (? profound deafness). Considering these reports, together with the familial cases of Duane's syndrome mentioned earlier, it is clear that the relationship between Duane's syndrome, perceptive deafness, and the Klippel-Feil anomaly has a genetic basis.

Wildervanck (1952, 1960) at first considered that the combination of these signs was fortuitous and ascribed the syndrome to the status dysraphicus, but later (1963) concluded that the syndrome was transmitted as a recessive trait. Wildervanck and others (1966) saw evidence of the status dysraphicus ("short necks", anencephaly, rachischisis) and of deafness among the relatives of their patients with the cervico-oculo-acusticus syndrome, and considered a multi-factorial inheritance to be the most likely explanation. Franceschetti and others (1966), in discussing their familial observation, considered that the triad was inherited as an irregular dominant character with variable expressivity of the responsible pleiotropic gene. Discussing the inheritance of Duane's syndrome in isolation, Waardenburg (1963) expressed the opinion that an irregular dominant gene effect was responsible. Fraser and MacGillivray (1968) detected chromosomal damage in one of their patients, a girl showing mental deficiency in addition to the full syndrome.

In the present series of 112 patients with Duane's syndrome, twelve (10.7 per cent.) had perceptive deafness and five (4.4 per cent.) had the Klippel-Feil anomaly. The families of several of these patients included other instances of Duane's syndrome or perceptive deafness, and in one family a female sibling who died in infancy was said to have shown multiple congenital deformities, including a neck abnormality.

Interpreting these findings in association with those in the literature, it seems reasonable to suggest that Duane's syndrome, the Klippel-Feil anomaly, and perceptive deafness are inherited as a single gene trait which is manifest in the heterozygote. The gene is incompletely penetrant and exhibits variable expressivity; thus the clinical picture is that of a

gene with pleiotropic effects inherited in an irregularly dominant manner. It is further suggested that the abnormal gene is partly sex-limited, acting on a polygenic background which is modified by sex in such a way that females are more susceptible or males are more resistant to the action of the gene. It is also possible that unknown environmental factors are of importance in modifying the expression of the gene.

In the large groups of isolated cases of Duane's syndrome, it is possible that some are not genetically determined but are the result of teratogenic agents to which the mother was exposed during pregnancy. Although in this series it has been ascertained that none of the mothers was diabetic and that there was no history of drug-taking or exposure to radiation and no history of rubella or other infections during pregnancy, this does not exclude the possibility of other unknown teratogenic agents.

Patients with Duane's syndrome in whom there was a history of the mother's having taken thalidomide during pregnancy have been described by Papst (1963) and Cullen (1967); in these patients abnormalities of the external ear were frequent. A series of five children with congenital ear deformities and deafness of a conductive nature due to atresia of the external auditory meatus was described by Livingstone and Delahanty (1968). These patients showed abnormal ocular movements indistinguishable from Duane's syndrome combined with weakness of the facial muscles resembling the Moebius syndrome; it is of interest that one of these patients showed the Klippel-Feil anomaly. The clinical features in these patients are so characteristic as to form a distinct syndrome; that thalidomide is not the only cause of this "toxic" Duane's syndrome is shown by an identical case reported by Warrington (1897). It is interesting that such environmental factors can act *in utero* to produce abnormal ocular movements indistinguishable from Duane's syndrome.

Summary

The literature relating to Duane's syndrome, perceptive deafness, and the Klippel-Feil anomaly is reviewed.

A series of 126 patients showing Duane's syndrome was studied and instances of perceptive deafness and the Klippel-Feil anomaly were found amongst these patients and their relatives.

It is concluded that the triad of Duane's syndrome, the Klippel-Feil anomaly, and perceptive deafness is inherited as a dominant condition with variable penetrance and expression. The gene is partially sex-limited and unknown environmental factors are possibly important in modifying its effect.

I wish to thank the Consultant Ophthalmologists of the United Sheffield Hospitals for allowing me to review their patients.

I am indebted to Miss Joyce Mein and the Staff of the Orthoptic Departments without whose help this study would not have been possible.

References

- BARDADIN, T., and SIEDLANOWSKA, H. (1955) *Otolaryng. pol.*, **9**, 25
 BAUMANN, G. I. (1932) *J. Amer. med. Ass.*, **98**, 129
 BEKEND, S. A. (1961) *Brit. orthopt. J.*, **18**, 100
 BEST (1903) *Dtsch. med. Wschr.*, **29**, Vereins-Beilage, p. 393
 BIELSCHOWSKY, A. (1939) "Graefe-Saemisch Handbuch der gesamten Augenheilkunde", 2nd ed., band 8, abteil 1, p. 353. Springer, Berlin
 BINTLIFF, S. J. (1965) *J. Amer. med. Wom. Ass.*, **20**, 547

- BIZARRO, A. H. (1938) *Lancet*, **2**, 828
- BÖHRINGER, H. R. (1952) *Arch. Klaus-Stift.*, **27**, 176
- CASELLATO, L., and MEUCCI, M. (1957) *Atti Soc. oftal. lombarda*, **12**, 278
- COHNEY, B. C. (1963) *Plast. reconstr. Surg.*, **31**, 179
- CULLEN, J. F. (1967) *Brit. orthopt. J.*, **24**, 2
- DIASALVES, D. (1961) *Rev. bras. Oftal.*, **20**, 339
- DUANE, A. (1905) *Arch. Ophthal. (N.Y.)*, **34**, 133
- DUKE-ELDER, S. (1964) "System of Ophthalmology", vol. 3, pt. 2, p. 993. Kimpton, London
- ENDELMAN, L. (1911) *Z. Augenheilk.*, **26**, 75
- ERSKINE, C. A. (1946) *A.M.A. Arch. Path.*, **41**, 269
- EVERBERG, G., RATJEN, E., and SORENSEN, H. (1963) *Brit. J. Radiol.*, **36**, 562
- FRANCESCHETTI, A., and KLEIN, D. (1954) *J. Génét. hum.*, **3**, 176
- , ———, BROCHER, J. E. W., and AMMANN, F. (1966) In "Genetics in Ophthalmology", *Acta Fac. med. Univ. Brun.*, **25**, 53
- FRANÇOIS, J., and VOS, E. DE (1958) *J. Génét. hum.*, **7**, 111
- FRASER, G. R. (1964) In "Research in Deafness in Children", ed. L. Fisch, p. 10. Blackwell Scientific Publications, Oxford
- FRASER, W. I., and MACGILLIVRAY, R. C. (1968) *J. ment. Defic. Res.*, **12**, 322
- GEDDA, L., and MAGISTRETTI, S. (1956) *Acta Genet. med. (Roma)*, **5**, 391
- GIFFORD, H. (1926) *Amer. J. Ophthal.*, **9**, 3
- GOLDFARB, C., and GANNON, F. L. (1964) *Dis. nerv. Syst.*, **25**, 17
- GUNDERSEN, T., and ZEAVIN, B. (1956) *A.M.A. Arch. Ophthal.*, **55**, 576
- GÜNSBURG, F. (1889) *Klin. Mbl. Augenheilk.*, **27**, 263
- HARLAN, G. C. (1885) *Trans. Amer. ophthal. Soc.*, **4**, 48
- KANBAYASHI, S., ICHIKAWA, H., TANI, H., MAKI, O., TAJI, M., and KAINO, T. (1967) *Rinsho Ganka*, **21**, 507
- KIRKHAM, T. H. (1969a) *Brit. J. Ophthal.*, **53**, 335
- (1969b) *Arch. Dis. Childh.*, **44**, 504
- KRAUS (1905) *Münch. med. Wschr.*, **52**, 1957
- LATTO, D. J. (1942) *Brit. med. J.*, **1**, 699
- LIVINGSTONE, G. H., and DELAHANTY, J. E. (1968) *J. Laryng.*, **82**, 495
- LODBERG, C. V. (1937) *Acta ophthal. (Kbh.)*, **15**, 247
- LYLE, T. KEITH, and WYBAR, K. C. (1967) "Lyle and Jackson's Practical Orthoptics in the Treatment of Squint", 5th ed., p. 573. Lewis, London
- MAGNUS, J. A. (1944) *Brit. J. Ophthal.*, **28**, 241
- MALBRÁN, J. (1949) "Estrabismos y paralisís". Editorial Oftalmológica Argentina, Buenos Aires
- MAU, C. (1924) *Z. orthop. Chir.*, **43**, 608
- McLAY, K., and MARAN, A. G. D. (1969) *J. Laryng.*, **83**, 175
- MEIN, J. (1968) In "Trans. I Int. Congr. Orthoptists, London, 1967", p. 165. Kimpton, London
- MITCHELL, H. S. (1934) *Arch. Dis. Childh.*, **9**, 213
- ORLOWSKI, W. J., KRYCH, J., and MICHNIEWSKA-LEONOWICZ, J. (1961) *Acta ophthal. (Kbh.)*, **39**, 6
- PAPST, W. (1963) *Ber. dtsh. ophthal. Ges. (Heidelberg)*, **65**, 209
- PETERS, A. (1921) *Arch. Augenheilk.*, **88**, 198
- PINTUCCI, F., and DI TIZIO, A. (1961) *J. Génét. hum.*, **10**, 156
- SCHLOSSMAN, A., and PRIESTLEY, B. S. (1952) *A.M.A. Arch. Ophthal.*, **47**, 1
- SCHWARZE, K. (1941) *Arch. orthop. Unfall-Chir.*, **41**, 47
- STOCKWELL, E. (1952) *A.M.A. Arch. Ophthal.*, **48**, 428
- THOMSON, J. (1937) *Arch. Dis. Childh.*, **12**, 127
- TÜRK, S. (1896) *Dtsch. med. Wschr.*, **22**, 199
- (1899) *Zbl. prakt. Augenheilk.*, **23**, 14
- VARESE, P. M. (1901) *Arch. Ottal.*, **9**, 143

- WAARDENBURG, P. J. (1923) *Amer. J. Ophthal.*, **6**, 44
——— (1932) "Das Menschliche Auge und seine Erbanlagen". Nijhoff, Den Haag
——— (1953) *v. Graefes Arch. Ophthal.*, **154**, 96
———, FRANCESCHETTI, A., and KLEIN, D. (1963) In "Genetics in Ophthalmology", vol. 2, p. 1119. Blackwell Scientific Publications, Oxford
WARRINGTON, W. B. (1897) *Ophthal. Rev.*, **16**, 99
WEEKERS, R., and DAENEN, P. (1955) *Bull. Soc. belge Ophthal.*, no. 109, p. 1
WHETNALL, E., and FRY, D. B. (1964) In "The Deaf Child", p. 103. Heinemann, London
WHITE, J. W., and BROWN, H. W. (1939) *Arch. Ophthal. (Chicago)*, **21**, 999
WILDERVANCK, L. S. (1952) *Ned. T. Geneesk.*, **96**, 2752
——— (1960) *Ibid.*, **104**, 2600
——— (1963) In "Proc II Int. Congr. Hum. Genet., Rome, 1961", vol. 3, p. 1409
———, HOEKSEMA, P. E., and PENNING, L. (1966) *Acta oto-laryng. (Stockh.)*, **61**, 445
WITZEL, S. H. (1958) *A.M.A. Arch. Ophthal.*, **59**, 463
WOLFF, J. (1900) *Arch. Ophthal. (N.Y.)*, **29**, 297
ZENTMAYER, W. (1935) *Amer. J. Ophthal.*, **18**, 861