

High Frequency cDNA Recombination of the *Saccharomyces* Retrotransposon Ty5: The LTR Mediates Formation of Tandem Elements

Ning Ke and Daniel F. Voytas

Department of Zoology and Genetics, Iowa State University, Ames, Iowa 50011

Manuscript received April 30, 1997
Accepted for publication July 10, 1997

ABSTRACT

Retroelement cDNA can integrate into the genome using the element-encoded integrase, or it can recombine with preexisting elements using the recombination system of the host. Recombination is a particularly important pathway for the yeast retrotransposon Ty5 and accounts for ~30% of the putative transposition events when a homologous substrate is carried on a plasmid and ~7% when the substrate is located at the chromosomal *URA3* locus. Characterization of recombinants revealed that they are either simple replacements of the marker gene or tandem elements. Using an assay system in which the donor element and recombination substrates are separated, we found that the long terminal repeats (LTRs) are critical for tandem element formation. LTR-containing substrates generate tandem elements at frequencies more than 10-fold higher than similarly sized internal Ty5 sequences. Internal sequences, however, facilitate tandem element formation when associated with an LTR, and there is a linear relationship between frequencies of tandem element formation and the length of LTR-containing substrates. We propose that recombination is initiated between the LTRs of the cDNA and substrate and that internal sequences promote tandem element formation by facilitating sequence alignment. Because of its location in subtelomeric regions, recombinational amplification of Ty5 may contribute to the organization of chromosome ends.

RETROTRANSPOSONS are a group of mobile genetic elements that replicate through an mRNA intermediate (BOEKE and SANDMEYER 1991). There are two major classes of retrotransposons, which are distinguished by whether or not they are flanked by long terminal direct repeats (LTRs). The LTR-containing retrotransposons replicate by a mechanism analogous to the retroviruses (BROWN and VARMUS 1989; BOEKE and SANDMEYER 1991). This replication cycle begins with the synthesis of an element mRNA that is translated to yield the protein products required for replication and also serves as a template for reverse transcription. Two major polyproteins are encoded by retrotransposon mRNA that are equivalent to retroviral *gag* and *pol* polyproteins. The *gag* gene products assemble into virus-like particles. Packaged inside these particles are template mRNAs and the *pol* gene products, which include protease, reverse transcriptase, integrase and RNase H. A cDNA synthesized in the particle through reverse transcription can enter the genome by one of two pathways: it can be integrated into the chromosome by the element-encoded integrase (BOEKE and SANDMEYER 1991) or it can recombine with preexisting elements. The latter pathway is mediated by the host recombination system (MELAMED *et al.* 1992; NEVO-CASPI and KUPIEC 1994, 1996; SHARON *et al.* 1994).

Corresponding author: Daniel F. Voytas, 2208 Molecular Biology Building, Iowa State University, Ames, IA 50011.
E-mail: voytas@iastate.edu

The yeast *Saccharomyces cerevisiae* has five distinct families of retrotransposons, designated Ty1–Ty5 (BOEKE and SANDMEYER 1991). The Ty1 elements have been studied extensively. Transposition assays have been developed in which Ty1 elements have been placed under the transcriptional control of the *GAL1* promoter and modified to carry selectable marker genes to monitor Ty1 replication. Genetically marked Ty1 cDNA that results from reverse transcription typically enters the yeast genome by the integration pathway. This cDNA can also recombine with a chromosomal Ty1 element such that the chromosomal element acquires the cDNA marker gene (MELAMED *et al.* 1992). In addition, Ty1 cDNA recombination can yield tandem elements, and they are frequently observed when the integration pathway is blocked (SHARON *et al.* 1994). Tandem elements have also been generated by wild-type Ty1 elements at the *HML* locus and other chromosomal loci (WEINSTOCK *et al.* 1990). This indicates that tandem elements are formed naturally, although the mechanism by which this occurs remains to be determined.

Retroelement reverse transcriptase can occasionally reverse transcribe cellular mRNAs. This process has important implications for genome evolution, because cellular cDNAs can integrate to new locations to generate gene duplications or pseudogenes. Cellular cDNA can also recombine with parental genes, and the paucity of introns in *S. cerevisiae* is likely due to such recombination events (FINK 1987). It has been shown that cDNA generated from *S. cerevisiae* *HIS3* mRNA either can re-

combine with the chromosomal *HIS3* locus or can be carried to new genomic locations through the action of a Ty1 element (DERR *et al.* 1991; DERR and STRATHERN 1993). Similar events have also been documented in mammalian cells and likely arise by aberrant reverse transcription (TCHENIO *et al.* 1993; MAESTRE *et al.* 1995).

An active Ty5 element, Ty5-6p, has been identified from the species *Saccharomyces paradoxus*. This element is 5376 bp long and is flanked by 251-bp LTRs (ZOU *et al.* 1996a). Endogenous *Saccharomyces* Ty5 elements are associated with the telomeres and the *HM* loci, and Ty5-6p has been shown to integrate preferentially into these sites (ZOU *et al.* 1995, 1996a). The telomeres and *HM* loci are bound in unique chromatin, called silent chromatin (LAURENSEN and RINE 1992), which directs Ty5 integration to these locations (ZOU and VOYTAS 1997). The subtelomeric regions of *S. cerevisiae* also contain other repeated sequences, namely *Y'* elements and X repeats (LOUIS 1995). *Y'* elements play a role in telomere structure and may have a biological function, as supported by the observation that the early senescence phenotype characteristic of certain telomere-length mutants (such as *est1*) can be overcome by amplification of *Y'* through recombination (LUNDBLAD and BLACKBURN 1993). The presence of Ty5 at subtelomeric regions suggests that it may also play a role in telomere structure. Consistent with this hypothesis, we demonstrate that Ty5 cDNA recombines at a high frequency, and Ty5 elements can amplify in copy number through tandem element formation. In addition, we describe an assay that has made it possible to identify sequences important for recombination. Using data obtained from this assay, we propose models for tandem element formation based on recombination between the LTRs of the cDNA and the substrate.

MATERIALS AND METHODS

Strains: Yeast strains used in this study were YPH499 (MATA, GAL, *trp1*Δ63, *ura3-52*, *leu2*Δ1, *his3*Δ200, *lys2-801*, *ade2-101*) and its isogenic derivatives. Integrative transformation was used to recombine the *GALI-Ty5* constructs into yeast chromosomes (HINNEN *et al.* 1978). pSZ157, which contains *GALI-Ty5his3AI* (see below) on the integration plasmid pRS406 (SIKORSKI and HIETER 1989), was linearized with *NcoI* before transforming YPH499 by the lithium acetate method to generate YNK277 (AUSUBEL *et al.* 1987). pNK298, which contains *GALI-Ty5neoAI* (see below) on the integration plasmid pRS305 (SIKORSKI and HIETER 1989), was linearized with *BstEII* and used to transform YPH499 to generate strain YNK364. Transposition assays using these strains were conducted to test the transposition competence of integrated Ty5 elements before further analysis. The *Escherichia coli* strain XL1-blue was used for DNA manipulations (Stratagene). Plasmids were introduced into yeast and *E. coli* by electroporation (AUSUBEL *et al.* 1987).

Plasmids: pNK254, which was used to evaluate cDNA recombination with plasmid-borne Ty5 elements, was constructed by cloning the *XhoI-SacII* fragment from pSZ152 (ZOU *et al.* 1996a) into the corresponding sites of the *CEN* plasmid pRS416 (SIKORSKI and HIETER 1989). This fragment

contains the Ty5 element under transcriptional control of *GALI-10* upstream activating sequences (UASs) and the *his3AI* selectable marker (referred to as *GALI-Ty5his3AI*). The Ty5 construct used to detect chromosomal recombination events, pSZ157, was made by cloning the *XhoI-SacII* fragment from pSZ152 into the integration plasmid pRS406. pNK298 was made by cloning the *XhoI-SacII* fragment containing the *GALI-Ty5neoAI* element from pXW25 (X. GAI and D. F. VOYTAS, unpublished results) into the integration plasmid pRS305. This plasmid was used to recombine the *GALI-Ty5neoAI* construct into the chromosomal *LEU2* locus.

The full-length Ty5 element used as a recombination substrate was made as follows: an *XhoI* site was introduced into the 5' LTR by PCR-amplifying a Ty5 subclone (pNK301) with the mutagenic primer DVO278 (5'-CCGCTCGAGTGTGA ATGTGATAACCCA-3') and the reverse primer. PCR fragments were digested with *XhoI* and *BamHI* and used to replace the corresponding fragment of pSZ147 to generate pNK318; this replaced the *GALI-Ty5* LTR with a native LTR. Ty5-containing fragments of pNK318 were cloned into pRS426 (CHRISTIANSON *et al.* 1992) to serve as recombination substrates (see Figure 6): pNK311 contains the *XhoI-BamHI* fragment; pNK313 contains the *XhoI-HindIII* fragment; pNK348 contains the 5' *HindIII-SmaI* fragment; pNK349 contains the *XhoI-SmaI* fragment; pNK350 contains the 3' *SmaI-HindIII* fragment. pNK311 was divided into two parts by introducing a *BamHI* site at the junction between the 5' LTR and the internal region by PCR based site-directed mutagenesis. This resulted in pNK317 (LTR sequences) and pNK354 (adjacent internal sequences).

An assay to distinguish between His⁺ plasmid and chromosomal events: pNK254, containing *GALI-Ty5his3AI*, was transformed into YPH499, and three independent Ura⁺ transformants were used for further study. Transposition assays were conducted as previously described (ZOU *et al.* 1996a) with minor modifications: patches of cells were made on synthetic complete medium without uracil (SC-U) glucose plates and allowed to grow at 30° for 2 days. Patches were then replica-plated onto SC-U/galactose plates and grown at room temperature (23°) for an additional 2 days to induce transposition. At this point, cells from each patch were scraped and resuspended in dH₂O. One hundred microliters of the cell suspension and a 10⁻⁴ dilution were plated onto synthetic complete medium without histidine (SC-H) and SC-U plates, respectively. Colonies were counted after 48 hr of growth at 30°. The frequency of His⁺ cells was calculated by dividing the colony number on SC-H plates by the product of the colony number on SC-U plates and the dilution factor.

To calculate the proportion of plasmid events, about 300 His⁺ colonies were picked and patched onto SC-H plates. Patches were grown for 2 days at 30° before being replica-plated onto SC-H medium with 5-fluoroorotic acid (SC-H/5-FOA). Plates were placed at 30° for an additional 2 days before scoring for growth. The proportion of plasmid events was calculated by dividing the number of patches that did not grow on SC-H/5-FOA plates by the number of patches that grew on SC-H plates.

Ten individual His⁺ strains with plasmid events were characterized by Southern blot analysis. Total yeast DNA was prepared and digested with *XhoI* or *HpaI*, which cut once in the vector or once in Ty5, respectively. DNA was separated on 0.8% agarose gels and transferred to nylon membranes by the alkaline transfer method (AUSUBEL *et al.* 1987). Filters were hybridized with a ³²P-labeled *HIS3* probe. Plasmids from representative strains were rescued in bacteria, restriction mapped and sequenced.

Frequency of cDNA recombination with a chromosomal Ty5 element: The yeast strain YNK277 with an integrated

GAL1-Ty5his3AI at the *URA3* locus was used to calculate the recombination frequency for a chromosomal Ty5 element. After induction of transposition, approximately 300 His⁺ colonies were picked and patched onto SC-H plates. The patches were grown at 30° for 2 days. Plates with patches were first replica-plated onto YPD plates and then SC/5-FOA plates. Finally, the patches were replica-plated onto SC-H/5-FOA plates. Patches that failed to generate His⁺/5-FOA⁻ colonies were considered putative recombination events (see Figure 3). These strains were retested before being subjected to Southern blot analysis. Genomic DNA was made from these strains, digested with *HpaI*, separated on 0.8% agarose gels, and transferred to nylon filters. The filters were hybridized with a ³²P-labeled *HIS3* probe. Twelve randomly chosen His⁺ strains were used as controls.

An assay to measure recombination frequencies for Ty5 fragments: A previously described Ty1 transposition assay was modified to measure recombination frequencies for different Ty5 fragments (DEVINE and BOEKE 1996). The *GAL1-Ty5neoAI* element on pNK298 was integrated into the *LEU2* locus to generate YNK364. The recombination target plasmids described above were introduced into this strain, and transposition assays were conducted. After induction of transposition by growth on galactose, patches were replica-plated onto YPD plates containing 200 µg/ml G418 (Sigma) to select for recombination and integration events. The G418^r cells were allowed to grow for 4 days at 30° before being used to make total DNA. One microliter of DNA (50–100 ng) was used to transform *E. coli* by electroporation. After 1/100 of the cells were plated onto LB-Amp plates, the remaining cells were plated onto LB-Amp/Kan plates. Recombinant frequencies (both plasmid integration and recombination events) were calculated by dividing the number of Amp^rKan^r colonies by the product of the number of colonies that were Amp^r and the dilution factor. Plasmids with or without Ty5 elements did not affect yeast growth rates and transformed *E. coli* with similar efficiencies (data not shown). Three independent patches for each construct were assayed, and recombinant frequencies were calculated by averaging the three values. For each recombination substrate, 11–18 Amp^rKan^r recombinants were characterized by restriction mapping or sequencing to determine whether they were derived by recombination.

RESULTS

Ty5 cDNA recombines at high frequency: The cDNA that is formed by reverse transcription of retrotransposon mRNAs can enter the genome either by integrating into new chromosome locations or by recombining with preexisting endogenous elements. We have previously identified a transposition-competent Ty5 element from *S. paradoxus* (Ty5-6p) and developed an assay to monitor Ty5 replication in *S. cerevisiae* (ZOU *et al.* 1996a). This assay uses a modified Ty5-6p donor element (*GAL1-Ty5his3AI*), which is transcriptionally regulated by *GAL1-10* upstream activating sequences. This element carries a *HIS3* marker gene that is interrupted by an artificial intron (*his3AI*) (CURCIO and GARFINKEL 1991). Because the intron is in the incorrect orientation to be spliced from *HIS3* mRNA, the intron inactivates *HIS3* expression in the donor element. However, the intron can be spliced from Ty5 mRNA. If this mRNA is used as a template for reverse transcription, a func-

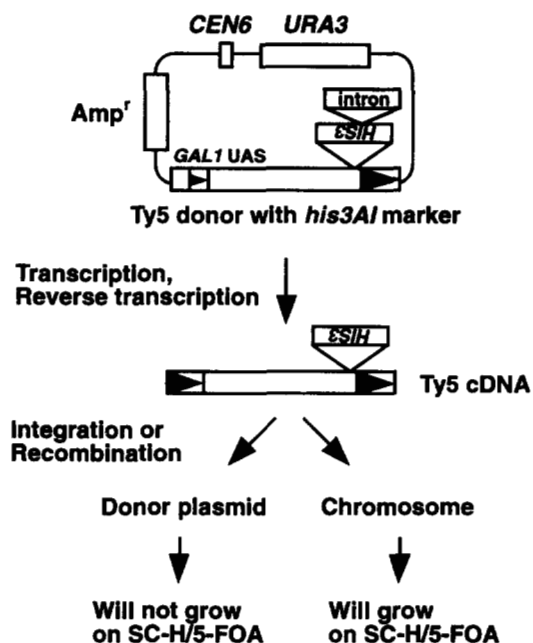

FIGURE 1.—An assay to distinguish between His⁺ chromosomal and plasmid events. A *GAL1-Ty5his3AI* is carried on an *URA3*-based *CEN* plasmid. After transcription and reverse transcription, Ty5 cDNAs with a functional *HIS3* gene are generated. The cDNAs can enter either plasmid targets (in this case the donor plasmid) or chromosomal targets. These two events can be distinguished because plasmid events will not grow on SC-H/5-FOA plates.

tional *HIS3* gene is reconstituted. A His⁺ phenotype may result from either integration or recombination of the cDNA.

We have previously shown that the majority of chromosomal His⁺ events are due to integration (ZOU *et al.* 1996a,b). The few endogenous Ty5 elements in *S. cerevisiae* are likely poor substrates for recombination, because they only share 70–90% sequence similarity with Ty5-6p. The donor plasmid, however, is a suitable target for recombination, because it carries a full-length, homologous Ty5 element. Chromosomal and plasmid events that generate His⁺ cells may be distinguished by the strategy shown in Figure 1. After induction of transposition, patches of individual His⁺ cells are grown on SC-H plates. This releases selection on the *URA3*-based donor plasmid unless the *HIS3* gene in the element is present. Patches are then replica-plated to SC-H media with 5-FOA. Cells containing the donor plasmid with the *URA3* gene cannot grow in the presence of 5-FOA (BOEKE *et al.* 1987), and therefore only His⁺ cells with chromosomal Ty5 insertions survive. Although cells carrying both plasmid and chromosomal events would yield a His⁺/5-FOA⁻ phenotype, such events are unlikely due to the low overall frequency that His⁺ cells are generated (5×10^{-5} ; Table 1). Using this assay, we found that 34.9% (104/298) of His⁺ cells carried a functional *HIS3* gene on the donor plasmids (Table 1).

Plasmid events may result from either recombination

TABLE 1
cDNA recombination with plasmid-borne *GALI-Ty5his3AI*

Strains	His ⁺ frequencies ($\times 10^{-5}$)	No. on SC-H	No. on SC-H/ FOA	Percent plasmid events
YNK366	4.98	106	73	31.1
YNK367	7.57	100	57	43.0
YNK368	3.58	92	64	30.4
Average/Total	5.38 ± 2.02	298	194	34.9

The His⁺ frequencies for three transformants were calculated by dividing the His⁺ cell number by the total Ura⁺ cell number. The proportion of plasmid events was calculated by dividing the His⁺/5-FOA^s cell number by the His⁺ cell number.

of Ty5 cDNA with the donor element or integration into the donor plasmid. To distinguish between these two possibilities, we characterized 10 individual His⁺ strains carrying plasmid recombinants by Southern blot analysis (Figure 2). Representative recombinants were rescued in *E. coli*, restriction mapped and sequenced (data not shown). All plasmid events arose by recombination and fell into two classes: either the intron in the donor element was removed by gene conversion or double crossover with a Ty5 cDNA (referred to as marker exchange), or the donor Ty5 and a Ty5 cDNA were present in tandem (referred to as tandem elements). These two classes could be distinguished by Southern hybridization analysis. Seven marker exchanges and three tandem elements were observed.

Ty5 cDNA recombination occurs efficiently with

chromosomal substrates: Our data suggest that the majority of Ty5 cDNA enters chromosomal targets by integration and plasmid targets by recombination. The lack of chromosomal recombination events may be because native elements are degenerate substrates; recombination between homeologous sequences is much lower than between homologous sequences (HARRIS *et al.* 1993). Alternatively, it may be caused by the differences in chromatin structure between plasmid and chromosomal substrates. To test whether Ty5 recombines efficiently with homologous chromosomal targets, we developed an assay to detect chromosomal recombination events (Figure 3). A *GALI-Ty5his3AI* element was integrated into chromosome V at the *URA3* locus such that it was flanked by wild-type and mutant *URA3* genes. This element may serve as a substrate for recombination

A. Maps of donor and recombinant Ty5 elements

Donor Ty5 with *his3AI*:



I. Marker exchange:

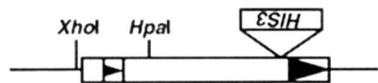

II. Tandem elements:

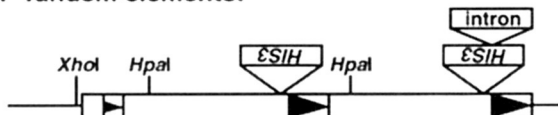

B. Characterization of plasmid recombinants

XhoI:

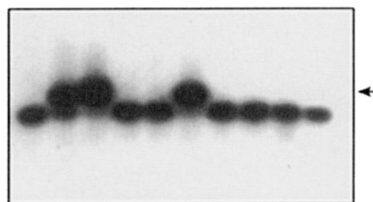

HpaI:

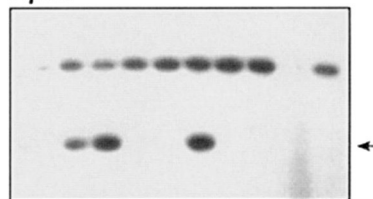
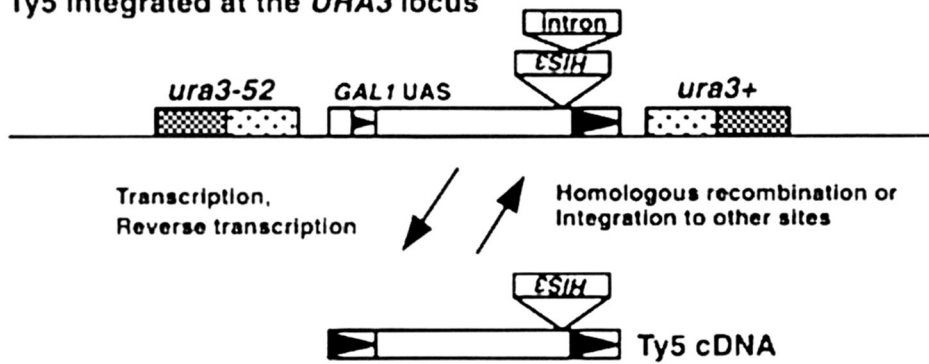

FIGURE 2.—Structural analysis of His⁺ plasmids. (A) Maps of plasmids carrying the donor and recombinant Ty5 elements. *XhoI* cuts once within the vector sequence and *HpaI* cuts once within Ty5. For elements that result from marker exchange (class I), the map is the same as the donor element with the exception of the loss of the intron. This class of elements could result by gene conversion or double crossover. However, if recombination generated tandem elements (class II), digestion with *XhoI* would generate a fragment 6.5 kb larger than the original plasmid (the size of a full length Ty5 plus the *HIS3* marker). Digestion with *HpaI* would generate two fragments: a 6.5-kb fragment and a fragment the size of the donor plasmid. (B) Southern blot analysis was conducted for 10 His⁺ strains with plasmid events. Filters containing *XhoI*- or *HpaI*-digested genomic DNA were hybridized with a ³²P-labeled *his3AI* probe. Seven marker exchanges and three tandem elements were observed. Arrows next to the blots indicate tandem or class II elements.

A. Ty5 integrated at the *URA3* locus



B. A method to distinguish between recombination and integration

Recombination:

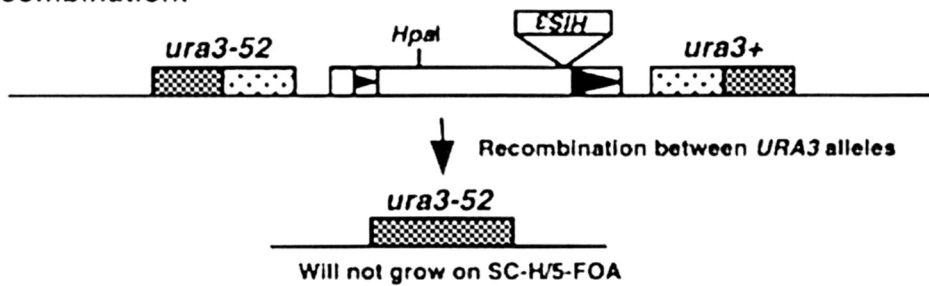

Integration:

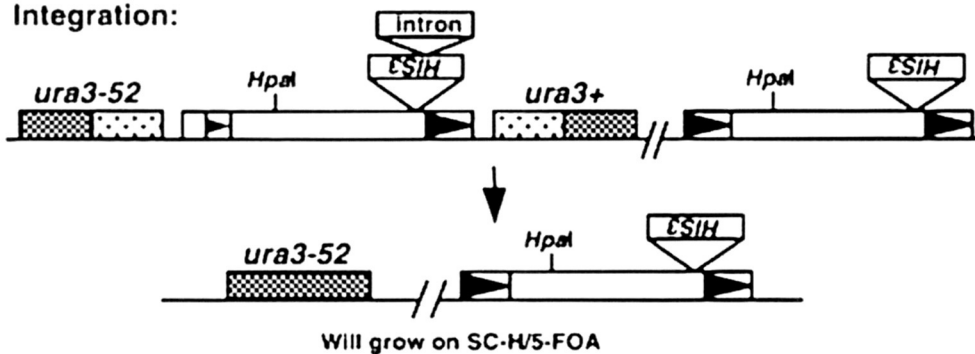

C. Structural analysis of putative chromosomal recombination events

Putative recombinants:

Randomly chosen events:

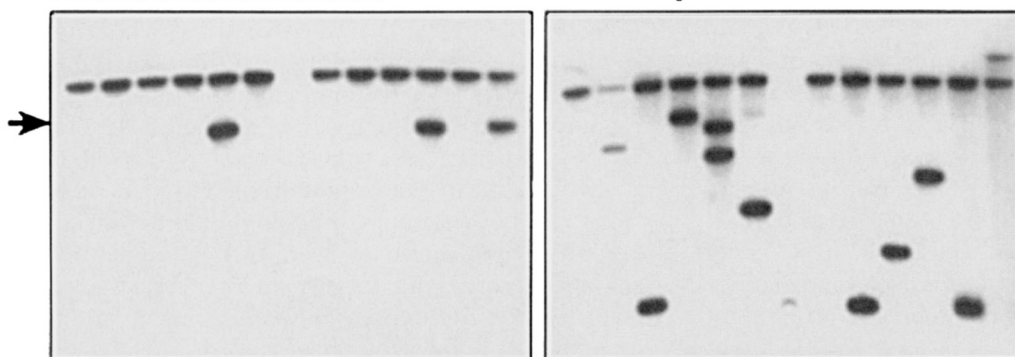

FIGURE 3.—Ty5 cDNA recombinates efficiently with a chromosomal substrate. (A) A *GAL1-Ty5^{hisAI}* was integrated into the chromosome at the *URA3* locus. After induction of Ty5 expression, Ty5 cDNA can enter the genome either through recombination or integration. (B) A method to detect cDNA recombination events. Recombination between the two *URA3* alleles would result in the deletion of the intervening Ty5 sequences and give 5-FOA resistance. Cells would also be His⁻ if the intervening Ty5 carried a functional *HIS3* gene due to cDNA recombination. However, if Ty5 cDNA went to other sites, the His⁺ phenotype would be retained. Thus putative recombination events can be identified by selecting for the His⁻/5-FOA⁺ phenotype. (C) Structural analysis of putative recombination events. In the left panel, 12 His⁺ strains carrying putative recombination events were subjected to Southern blot analysis. The DNA was digested with *HpaI* and hybridized with a ³²P-labeled *his3AI* probe. Nine of the putative recombination events were marker exchanges, while the other three were tandem elements. The right panel shows 12 randomly chosen His⁺ strains that served as controls. Two are recombination events (later confirmed to yield His⁻/5-FOA⁺ cells), while the other 10 are integration events. The arrow next to the blots indicates tandem elements.

with Ty5 cDNA to give rise to His⁺ cells (Figure 3A). A second recombination event between the *URA3* genes would generate a defective *URA3* allele, with concomitant loss of the intervening Ty5 (Figure 3B). If the His⁺ phenotype was derived through Ty5 cDNA recombination with the chromosomal donor Ty5 element, then recombination between the *URA3* genes would delete the functional *HIS3* gene and result in a His⁻/5-FOA^r phenotype.

A transposition assay was conducted, and His⁺ cells were patched onto SC-H media. Patches were first replica-plated onto rich media and then to SC/5-FOA media to select for the defective *URA3* gene. Finally, the patches were replica-plated onto SC-H/5-FOA media. By screening 300 His⁺ colonies, we found 22 candidates that may have been generated by cDNA recombination back to the chromosomal donor element. Southern blot analysis of 12 candidates indicated that all were recombination events (Figure 3C), and all gave rise to His⁻/5-FOA^r cells. This yielded an overall recombination frequency of ~7%. The characterized recombination events fell into two categories: nine resulted from marker exchange and three were tandem elements. The ratio between these two classes (9/3) is very similar to that observed for recombination with plasmid substrates (7/3). Southern blot analysis was also conducted on 12 randomly chosen His⁺ cells; 10 were integration events and two were recombination events. The two recombination events were found to give rise to His⁻/5-FOA^r cells, whereas the 10 integration events were His⁺/5-FOA^r. Although the chromosomal recombination frequency (7%) is much lower than for plasmid substrates (34.9%), cDNA recombination is still efficient considering that the Ty5 integration frequency to highly preferred chromosomal targets (e.g. *HMR-E*) is only ~3% (ZOU *et al.* 1996a).

An assay to identify sequences that facilitate Ty5 cDNA recombination: To determine whether certain Ty5 sequences are important for recombination, we developed an assay that separates the donor Ty5 element from the substrate. This assay allows recombination efficiencies to be measured using different Ty5 fragments as substrates (Figure 4). In this assay, a *GALI*-Ty5 was integrated into the chromosomal *LEU2* locus to serve as the cDNA donor. To facilitate the recovery of recombination events, the *his3AI* marker was replaced by *neoAI*. The *neo* gene confers G418 resistance to yeast and kanamycin resistance to bacteria. Plasmids carrying Ty5 or Ty5 fragments were then introduced into this strain to serve as recombination substrates. After induction of Ty5 transcription on galactose, transposition and recombination events were selected on YPD-G418 plates. Recombinant frequencies (both plasmid integration and recombination events) were measured by making total DNA from the G418^r cells and transforming the DNA into bacteria. All recovered plasmids confer an Amp^r phenotype, while recombinants confer an

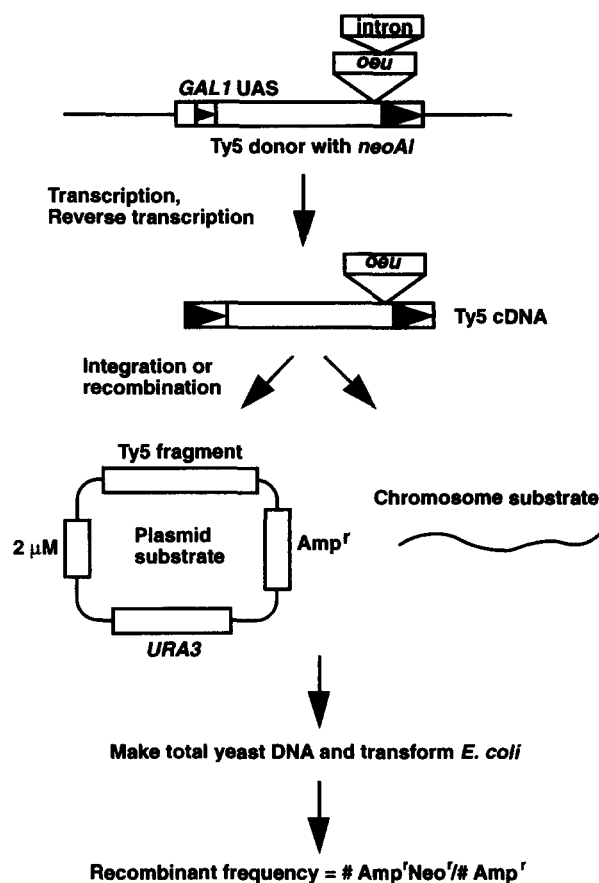
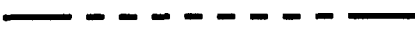
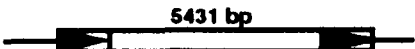

FIGURE 4.—An assay to measure recombinant frequencies for Ty5 fragments. A donor *GALI*-Ty5-*neoAI* element is integrated at the chromosomal *LEU2* locus, and cDNA recombination is measured to plasmid substrates carrying different Ty5 fragments. After induction of Ty5 expression, integration and recombination events are selected on YPD-G418 plates. Total yeast DNA is made from G418^r cells and transformed into *E. coli*. Recombinants can be selected by their Amp^rKan^r phenotype. Recombinant frequencies for different substrates are calculated by dividing the number of Amp^rKan^r colonies by the total number of Amp^r colonies.





Amp^rKan^r phenotype. The ratio between Amp^rKan^r cells and the total Amp^r cells reflects the recombinant frequency of a particular target. Representative recombinants were characterized through restriction mapping or DNA sequencing to determine whether they were derived from recombination or integration.

Using this assay, we found that the recombinant frequency for plasmids with a full-length Ty5 was more than 100-fold higher than the negative control (no Ty5 sequences present), indicating that this assay can effectively measure Ty5 recombination (Figure 5A). The recombination frequency for full-length substrates (4.3%), however, was approximately eightfold lower than observed in the original assay (34.9%; Table 1). This may be due to methodological differences; the second assay involved recovery of recombinants in *E. coli* and substrates did not carry marker gene homology. Alternatively, differences between assays in the tran-

A. Recombinant frequencies

Strains	Targets	Ty5 fragments	Frequencies (%)
YNK319	pRS426		0.037 ± 0.001
YNK334	pNK318		4.312 ± 0.482

B. Characterization of recombinants for full length Ty5 substrates

Forms of recombinants	# recombinants/ # analyzed (%)
Marker exchange: 	20/39 (51.3%)
Tandem elements: 	12/39 (30.8%)
	0/39 (<2.5%)
	0/39 (<2.5%)

scriptural status of the substrate may influence cDNA recombination (NEVO-CASPI and KUPIEC 1994).

Characterization of recombinants showed that of the four analyzed from the negative control, all were due to integration (data not shown). However, of 39 plasmid recombinants characterized for the Ty5 substrate, all were derived from recombination (Figure 5B). Twenty of these (51.3%) were due to marker exchange, 12 (30.8%) were tandem elements, and the other seven (17.9%) were tandem elements associated with sequence rearrangements (data not shown). The ratio of marker exchange to tandem elements (20/12) was lower than in the previous assays (7/3), probably because the Ty5 substrate does not have the *neoAI* sequences to facilitate marker exchange. Detailed restriction maps of 12 tandem elements revealed that all have only one copy of the *neo* gene, and this marker resides in the 5' element (Figure 5B). This suggested that most tandem elements are formed when the Ty5 cDNA recombines either with the 5' LTR or with the internal region upstream of the marker.

The Ty5 LTR mediates tandem element formation: To identify Ty5 sequences important for tandem element formation, different Ty5 fragments were used as recombination substrates in the assay described above. To eliminate marker exchange, only Ty5 fragments from the 5' LTR to the site of *neoAI* insertion were tested. Recombinant frequencies were calculated by the methods described in Figure 4. Eleven to 18 recombinants for each construct were characterized by

restriction mapping. Ty5 fragments with or without an LTR were first tested and the results are shown in Figure 6A. The results can be summarized as follows: (1) the recombinant frequencies for fragments containing the 5' LTR are much higher compared to similarly sized internal fragments. For instance, pNK349 was 5.3-fold higher than pNK350 and 40-fold higher than pNK348. (2) Most of the recombinants characterized from LTR or LTR-containing substrates were due to recombination (*e.g.*, at least 72.7% for pNK317). However, for the internal fragment on pNK350, only 16.7% of the recombinants (2/12) were due to recombination. This indicates that the actual recombination frequency for the internal fragment on pNK350 is an additional six-fold lower, and the overall recombination frequency is 31.8-fold lower than pNK349 [*i.e.*, (2.04% × 17/17) / (0.39% × 2/12)]. (3) There is a linear relationship between recombination frequencies and the size of LTR-containing substrates (Figure 6C).

The data in Figure 6A suggest that because the internal Ty5 sequences in pNK348 are not a good recombination substrate, the high frequency recombination observed for pNK349 is mediated by the LTR and/or the adjacent internal sequences. This is supported by the relatively high frequency of recombination observed for pNK313, which only carries these sequences. To test whether the 5' LTR or sequences immediately adjacent are important for tandem element formation, these sequences were separated onto two plasmids (pNK317 and pNK354) (Figure 6B). The recombinant frequency

FIGURE 5.—Ty5 cDNA recombination with full-length Ty5 substrates. (A) Frequencies of recombinant formation are shown for full-length Ty5 and control (no Ty5) substrates. The recombinant frequency (plasmid recombination plus integration events) was calculated as shown in Figure 4. The recombinant frequency with the full-length Ty5 is more than 100-fold higher than the negative control. (B) Structural characterization of recombinants for the full-length Ty5 substrate. The recombinants were analyzed by restriction mapping, and the numbers of marker exchanges and tandem elements are shown. The seven recombinants that did not fit the depicted classes are tandem elements with deletions and/or rearrangements.

A.

Strains	Recombination substrates	Ty5 fragments	Recombinant frequencies (%)	Recombination proportion	Recombination frequencies (%)
YNK319	pRS426	-----	0.037 ± 0.001	0/4	0.000 ± 0.000
YNK353	pNK349	▬ 2007 bp	2.036 ± 0.052	17/17	2.036 ± 0.052
YNK328	pNK313	▬ 436 bp	0.424 ± 0.108	11/12	0.389 ± 0.099
YNK331	pNK317	▬ 251 bp	0.263 ± 0.048	8/11	0.191 ± 0.035
YNK350	pNK348	▬ 1571 bp	0.050 ± 0.060	N/D	N/D
YNK355	pNK350	▬ 3113 bp	0.385 ± 0.015	2/12	0.064 ± 0.003

B.

Strains	Recombination substrates	Ty5 fragments	Recombinant frequencies (%)	Recombination proportion	Recombination frequencies (%)
YNK325	pNK311	▬ 605 bp	1.531 ± 0.181	18/18	1.531 ± 0.181
YNK331	pNK317	▬ 251 bp	1.207 ± 0.245	8/11	0.878 ± 0.178
YNK358	pNK354	▬ 354 bp	0.368 ± 0.001	2/12	0.061 ± 0.000

C.

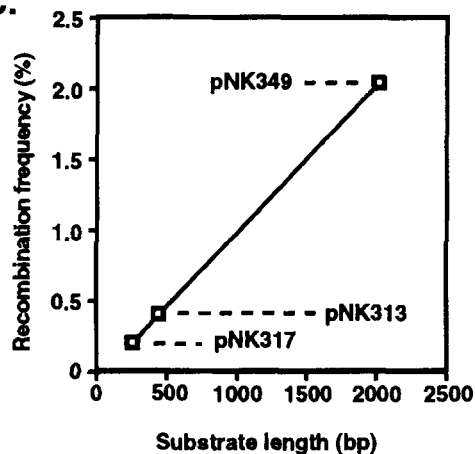

FIGURE 6.—Ty5 LTRs promote tandem element formation. (A) Recombinant frequencies, recombination proportions and recombination frequencies are shown for different Ty5 fragments. Recombinant frequencies were calculated by dividing the number of Amp^rKan^r colonies by the total number of Amp^r colonies (illustrated in Figure 4). The proportion of recombination events was determined by restriction mapping 11–18 recombinants generated from each Ty5 substrate. The recombination frequencies are the product of the recombinant frequency and recombination proportion for each Ty5 fragment. (B) Recombinant frequencies, recombination proportions and recombination frequencies for the 5' LTR and 5' internal sequences. The experiment was conducted as described in part A. (C) Linear regression analysis of recombination frequencies and substrate sizes for the LTR-containing fragments. The data were derived from part A.

for the internal fragment was 3.3-fold lower (1.207/0.368) compared to the LTR alone. Characterization of recombinants generated with the internal fragment revealed only 2/12 were due to recombination, compared to 8/11 for the LTR fragment. This makes the actual recombination frequency an additional 4.4-fold lower (Figure 6B) and the overall recombination frequency 14.5-fold lower (*i.e.*, 3.3×4.4) relative to the similarly sized LTR fragment. The LTR, therefore, is very important in mediating tandem element formation, and recombination is enhanced when internal sequences are present in conjunction with an LTR.

DISCUSSION

Because retrotransposons are components of all eukaryotic genomes, they have likely played an important

role in shaping the genetic material. Integration can have deleterious consequences for the host by causing gene mutations. On the other hand, retrotransposon insertions may be advantageous; for example, some insertions that alter gene expression have been shown to contribute important transcriptional control sequences (BOEKE and SANDMEYER 1991; WHITE *et al.* 1994; KNIGHT *et al.* 1996). Some retrotransposons, particularly those of *S. cerevisiae*, display a strong target bias for integration (CURCIO and MORSE 1996). Targeted integration can have significant effects on chromosome organization due to the accumulation of retrotransposons at particular chromosomal sites (KIM 1996). While the genetic effects of integration have been well documented, it has become increasingly clear that recombination of retrotransposon cDNA into the genome can also shape the genetic material. Studies with Ty1 elements have

shown that Ty1 cDNA can recombine with preexisting insertions to generate simple replacements or to form tandem elements (WEINSTOCK *et al.* 1990; MELAMED *et al.* 1992; SHARON *et al.* 1994). Cellular mRNA may also occasionally get reverse transcribed by retroelements. The resulting cDNA can integrate to form processed pseudogenes or recombine with its nuclear homologue (FINK 1987; DERR *et al.* 1991; DERR and STRATHERN 1993; TCHENIO *et al.* 1993; MAESTRE *et al.* 1995).

The Ty5 elements of *Saccharomyces* are an ideal system to study cDNA recombination. *S. cerevisiae* does not have any transposition-competent Ty5 elements, and endogenous Ty5 sequences are predominantly solo LTRs (ZOU *et al.* 1995). These sequences share from 70 to 90% nucleotide identity with the active element, Ty5-6p, which originates from *S. paradoxus* and is used in our transposition assays. The endogenous elements do not appear to be good substrates for recombination, as none of the 34 previously characterized *de novo* chromosomal insertions resulted from recombination (ZOU *et al.* 1996a,b). This apparent absence of recombination with endogenous elements makes it possible to monitor recombination between a genetically marked donor Ty5-6p cDNA and a particular Ty5-6p substrate by the gain of the marker in the substrate. We have exploited this advantage of the Ty5 system to better understand mechanisms of cDNA recombination.

High frequency cDNA recombination with a plasmid-borne Ty5 element: Ty5 cDNA is highly recombinogenic. More than 30% of the His⁺ cells observed in transposition assays are due to recombination of Ty5 cDNA with the plasmid-borne donor element. This is quite striking, especially since no plasmid events were observed when a wild-type Ty1 element was used in a similar assay (0/586 His⁺ events characterized) (SHARON *et al.* 1994). We have observed two classes of products that resulted from Ty5 cDNA recombination: elements that have undergone a marker exchange and tandem elements. The two classes were observed in the ratio of seven marker exchanges to three tandem elements. Our observations for Ty5 cDNA recombination are very similar to what has been observed for Ty1 elements when the integration pathway is genetically blocked. In Ty1 integrase mutants, cDNA that is normally destined for integration becomes available for high frequency recombination (SHARON *et al.* 1994). The high frequency cDNA recombination observed for wild-type Ty5 elements suggests that Ty5 cDNA is readily accessible for recombination.

Chromosomal recombination of Ty5 cDNA: Although Ty5 cDNA recombines at high frequency with plasmid-borne elements, we have never previously detected chromosomal recombination events. We propose two reasons why this might be the case: (1) endogenous Ty5 sequences share only 70–90% identity with the Ty5-6p element used in the transposition assays. Recombination between homeologous sequences is

much lower than between homologous sequences, and mismatch repair systems have been shown to limit recombination between diverged recombination substrates (HARRIS *et al.* 1993; SELVA *et al.* 1995; DATTA *et al.* 1996). In addition, the only *S. cerevisiae* Ty5 element with internal sequence contains a 2.3-kb deletion. This would likely further reduce its ability to recombine. (2) Alternatively, the low level of chromosomal recombination could be due to differences between chromosomal and plasmid substrates. Such differences have been reported for mating-type switching, the function of sequences involved in DNA replication, the expression of *HML* and *HMR*, and other biological processes influenced by chromatin structure (BRAND *et al.* 1985; MAHONEY and BROACH 1989; COLLINS and NEWLON 1994; SUGAWARA *et al.* 1995).

To distinguish between these two possibilities, we developed an assay that measures cDNA recombination with an homologous chromosomal element. We found that the recombination frequency for a chromosomal element approximated 7%. This is much lower than single-copy, plasmid-borne Ty5 elements (>30%) and indicates that the location of Ty5 recipient elements affects recombination frequency. However, Ty5 recombination is still efficient, considering that the integration frequency to a preferred genomic target such as *HMR-E* is ~3%.

High-frequency Ty5 cDNA recombination to plasmid and chromosomal targets could result because Ty5 cDNA is more available to the recombination machinery compared to the other Ty elements. Alternatively, Ty5 integration could be relatively inefficient, allowing the recombination pathway to predominate. Because random integration of retrotransposons may have deleterious effects on the host, the *S. cerevisiae* retrotransposons appear to have evolved mechanisms to target integration to noncoding regions (JI *et al.* 1993; CURCIO and MORSE 1996). Ty5 cDNA recombination provides another mechanism to target cDNA to nondeleterious chromosomal locations to maintain or increase the number of functional elements.

Recent work has shown that nonhomologous recombination of Ty1 cDNA can repair chromosomal double-strand breaks (BOEKE 1996; MOORE and HABER 1996; TENG *et al.* 1996). Interestingly, this chromosomal repair mechanism was observed more frequently in Ty1 integrase mutants (TENG *et al.* 1996). Both homologous and nonhomologous recombination, therefore, appear to require high availability of cDNA. The high frequency of Ty5 cDNA recombination suggests that it may be available to serve a similar role in repairing chromosomal breaks.

Mechanisms for tandem element formation: By separating the Ty5 cDNA donor from the recombination substrates, we have established an assay system to systematically test different Ty5 substrates for their effectiveness in generating recombinant products. We have fo-

A. Recombination of tandem cDNAs**B. Recombination of linear cDNA; internal domain homology does not facilitate recombination****C. Recombination of linear cDNA; internal domain homology facilitates recombination****D. Recombination of a solo-LTR circle; internal domain homology facilitates recombination**

FIGURE 7.—Models for formation of tandem elements. Only double-stranded cDNA molecules are considered as the recombination intermediates. Both strands of linear cDNAs are shown recessed from the 5' ends of the LTRs (---), resulting in single-stranded 3' ends that could then invade the homologous substrate. The resolution of the recombination intermediates would result in formation of tandem elements. Arrows depict LTRs. (A) Recombination of tandem cDNAs through LTRs would generate recombinants with marker genes in both elements. (B) Recombination of a single linear cDNA through the LTR by the ends-out mechanism would generate recombinants with marker genes equally distributed between the 5' and 3' elements. (C) Recombination of a single-copy linear cDNA through the LTR by the ends-in mechanism would generate recombinants with marker genes predominantly in the 5' element; the 5' LTR would be favored due to 5' internal domain homology that can facilitate alignment. (D) A solo LTR circle carrying a nick in its LTR can recombine with an LTR in the substrate. Recombinants would predominantly have marker genes in the 5' element due to 5' internal domain homology that facilitates alignment.

cused our efforts on identifying sequences important for tandem element formation, which constitute 30% of the Ty5 cDNA recombination events. In particular, we have found that the LTR is critical; LTR-containing fragments are at least 10-fold better substrates for tandem element formation relative to similarly sized internal sequences. Internal fragments, although not good recombination substrates themselves, can facilitate tandem element formation when associated with LTR fragments.

Tandem elements have previously been observed for Ty1 insertions at *HML* and other chromosomal loci (WEINSTOCK *et al.* 1990). Ty1 mutations that affect integration also give rise to tandem Ty1 arrays generated by recombination (SHARON *et al.* 1994). Two possibilities have been put forward to explain tandem element formation (SHARON *et al.* 1994): (1) aberrant strand transfer during reverse transcription or recombination between Ty1 cDNAs may result in tandem cDNA molecules, which could then recombine with preexisting Ty1

insertions, or (2) single copy Ty1 cDNAs could recombine with preexisting Ty1 insertions. On the basis of these possibilities and our observed importance for LTRs in mediating tandem element formation, we considered four models to explain the formation of tandem elements: (1) tandem cDNAs could recombine with targets through LTR sequences. Recombinants would carry the marker genes on both elements (Figure 7A). (2) Single-copy linear cDNAs could recombine with targets through LTR sequences by an ends-out mechanism to generate tandem elements (HASTINGS *et al.* 1993); the marker gene would be equally distributed between 5' and 3' elements (Figure 7B). (3) Single-copy linear cDNAs could recombine with targets through LTR sequences by an ends-in mechanism to generate tandem elements with the marker gene predominantly in 5' element (HASTINGS *et al.* 1993) (Figure 7C). (4) Recombination between LTRs in single-copy linear cDNAs could generate nicked solo-LTR circles. These nicked circles could recombine with targets through the LTRs

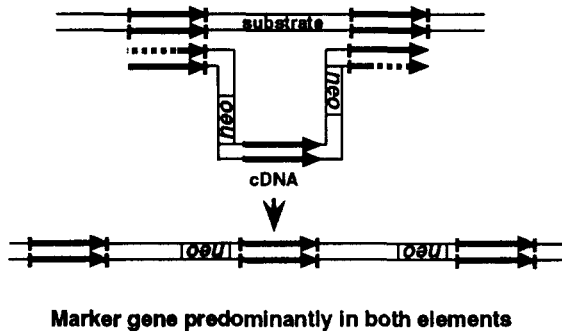
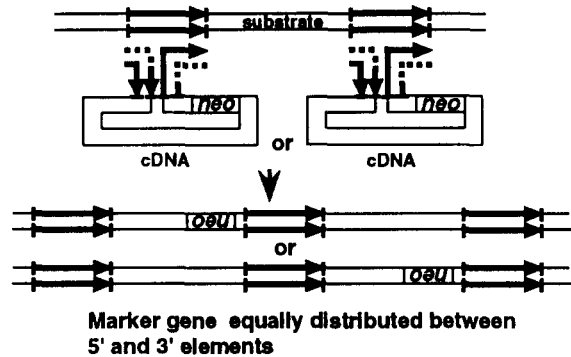
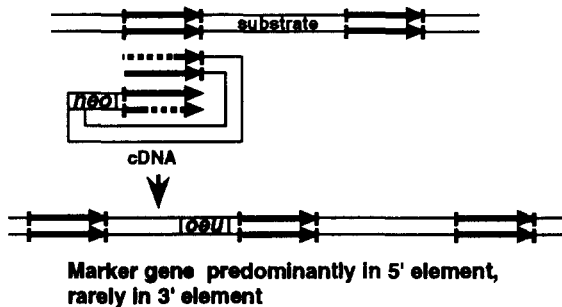
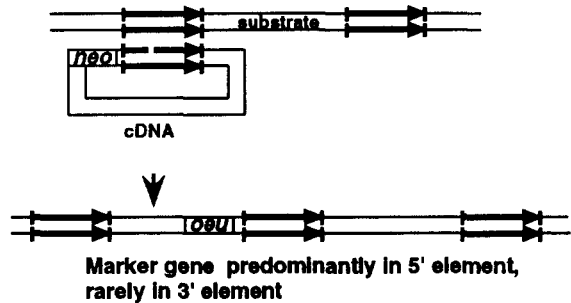
to generate tandem elements with the marker genes predominantly in 5' element (Figure 7D). Models 3 and 4 would predict that the 5' LTR is the preferred substrate, because 5' internal sequences can facilitate alignment with the cDNA. This cannot occur with the substrate's 3' LTR, because adjacent internal domain sequences differ by the presence of the marker gene in the cDNA; cDNA without marker genes would be predicted to recombine with both LTRs with equal efficiency.

Our observation that all 12 tandem elements characterized for the full-length Ty5 substrate carry the marker gene in the 5' element is consistent with models 3 and 4. Furthermore, models 3 and 4 predict a role for 5' internal sequences in aligning cDNA and target, which could explain the linear relationship observed between frequencies of tandem element formation and the length of LTR-containing substrates. While we assume that the cDNA molecules which participate in recombination are double stranded, single stranded cDNAs or partially double stranded cDNAs could also recombine to generate tandem elements. Further characterization of the cDNA recombination intermediates should help distinguish among these possibilities.

Interestingly, the linear relationship shown between Ty5 cDNA recombination frequencies and the length of LTR-containing fragments is very similar to what was observed by JINKS-ROBERTSON *et al.* (1993) for mitotic recombination between *URA3* repeats in *S. cerevisiae*. A linear relationship between recombination frequency and substrate length has also been observed in *S. cerevisiae* by other investigators, as well as in mammalian systems and *E. coli* (RUBNITZ and SUBRAMANI 1984; SHEN and HUANG 1986; LISKAY *et al.* 1987; AHN *et al.* 1988; SUGAWARA and HABER 1992). Our findings indicate that like mitotic recombination, cDNA recombination is homology and substrate length dependent.

Ty5 and telomere structure: The preference for Ty5 to integrate at telomeres suggests it plays a role in telomere structure. The *Drosophila melanogaster* non-LTR retrotransposons *Het-A* and *TART* serve as telomeres (BIESSMANN *et al.* 1990; LEVIS *et al.* 1993), indicating that retroelements can play essential roles in chromosome maintenance. In *S. cerevisiae*, subtelomeric *Y'* elements can amplify by recombination to form tandem arrays (LOUIS and HABER 1992; LUNDBLAD and BLACKBURN 1993). Amplification of *Y'* elements can suppress telomere-length mutations, such as mutations in the *EST1* gene. *Y'* amplification allows *est1* cells to survive even though they gradually lose telomeric repeats (LUNDBLAD and BLACKBURN 1993). Ty5, which is also subtelomeric and forms tandem elements efficiently, may serve a similar role. Considering our observation that tandem element formation is mediated by Ty5 LTRs, the relatively high number of solo LTRs in the subtelomeric regions of *S. cerevisiae* and *S. paradoxus* could provide abundant targets for recombinational amplifi-

cation. Recently, we observed that Ty5 cDNA can recombine with telomeric substrates at high frequency (N. KE and D. F. VOYTAS, unpublished results). It will be of interest to determine whether Ty5 amplification can also suppress telomere-length mutations in genes such as *EST1*.

We are grateful to GIOVANNI BOSCO, XIAOWU GAI and SIGE ZOU for critical reading of the manuscript. This work was supported by a grant from the American Cancer Society (VM145) and an American Cancer Society Junior Faculty Research Award to D.F.V. This is Journal Paper no. J-17283 of the Iowa Agriculture and Home Economics Experiment Station, Ames, Iowa, Project no. 3120 and was supported by Hatch Act and State of Iowa Funds.

LITERATURE CITED

- AHN, B.-Y., K. J. DORNFELD, T. J. FAGRELIUS and D. M. LIVINGSTON, 1988 Effect of limited homology on gene conversion in a *Saccharomyces cerevisiae* plasmid recombination system. *Mol. Cell. Biol.* **8**: 2442-2448.
- AUSUBEL, F. M., R. BRENT, R. E. KINGSTON, D. D. MOORE, J. G. SEIDMAN *et al.*, 1987 *Current Protocols in Molecular Biology*. Greene/Wiley Interscience, New York.
- BIESSMANN, H., J. M. MASON, K. FERRY, M. D'HULST, K. VALGEIRSDOTTIR *et al.*, 1990 Addition of telomere-associated *HeT* DNA sequences "heals" broken chromosome ends in *Drosophila*. *Cell* **61**: 663-673.
- BOEKE, J., 1996 A little help for my ends. *Nature* **383**: 579-581.
- BOEKE, J. D., and S. B. SANDMEYER, 1991 Yeast transposable elements, pp. 193-261 in *The Molecular and Cellular Biology of the Yeast Saccharomyces*, edited by J. BROACH, E. JONES and J. PRINGLE. Cold Spring Harbor Laboratory, Cold Spring Harbor, NY.
- BOEKE, J. D., J. TRUEHEART, G. NATSOULIS and G. R. FINK, 1987 5-fluoroorotic acid as a selective agent in yeast molecular genetics. *Methods Enzymol.* **154**: 164-175.
- BRAND, A. H., L. BREEDEN, J. ABRAHAM, R. STERNGLANZ and K. NASMYTH, 1985 Characterization of a "silencer" in yeast: a DNA sequence with properties opposite to those of a transcriptional enhancer. *Cell* **41**: 41-48.
- BROWN, P., and H. VARMUS, 1989 Retroviruses, pp. 53-108 in *Mobile DNA*, edited by D. E. BERG and M. M. HOWE. American Society for Microbiology, Washington DC.
- CHRISTIANSON, T. W., R. S. SIKORSKI, M. DANTE, J. H. SHERO and P. HIETER, 1992 Multifunctional yeast high-copy-number shuttle vectors. *Gene* **110**: 119-122.
- COLLINS, I., and C. S. NEWLON, 1994 Chromosomal DNA replication initiates at the same origins in meiosis and mitosis. *Mol. Cell. Biol.* **14**: 3524-3534.
- CURCIO, M. J., and D. J. GARFINKEL, 1991 Single-step selection for Ty1 element retrotransposition. *Proc. Natl. Acad. Sci. USA* **88**: 936-940.
- CURCIO, M. J., and R. H. MORSE, 1996 Tying together integration and chromatin. *Trends Genet.* **12**: 436-438.
- DATTA, A., A. ADJIRI, L. NEW, G. F. CROUSE and S. JINKS-ROBERTSON, 1996 Mitotic crossovers between diverged sequences are regulated by mismatch repair proteins in *Saccharomyces cerevisiae*. *Mol. Cell. Biol.* **16**: 1085-1093.
- DERR, L. K., and J. N. STRATHERN, 1993 A role for reverse transcripts in gene conversion. *Nature* **361**: 170-173.
- DERR, L. K., J. N. STRATHERN and D. J. GARFINKEL, 1991 RNA-mediated recombination in *S. cerevisiae*. *Cell* **67**: 355-364.
- DEVINE, S. E., and J. D. BOEKE, 1996 Regionally-specific, targeted integration of the yeast retrotransposon Ty1 upstream of genes transcribed by RNA polymerase III. *Genes Dev.* **10**: 620-633.
- FINK, G. R., 1987 Pseudogenes in yeast? *Cell* **49**: 5-6.
- HARRIS, S., K. S. RUDNICKI and J. E. HABER, 1993 Gene conversions and crossing over during homologous and homeologous ectopic recombination in *Saccharomyces cerevisiae*. *Genetics* **135**: 5-16.
- HASTINGS, P. J., C. MCGILL, B. SHAFER and J. N. STRATHERN, 1993 Ends-in vs ends-out recombination in yeast. *Genetics* **135**: 973-980.

- HINNEN, A., J. B. HICKS and G. R. FINK, 1978 Transformation of yeast. *Proc. Natl. Acad. Sci. USA* **75**: 1929–1933.
- JI, H., D. P. MOORE, M. A. BLOMBERG, L. T. BRAITERMAN, D. F. VOYTAS *et al.*, 1993 Hotspots for unselected Ty1 transposition events on yeast chromosome III are near tRNA genes and LTR sequences. *Cell* **73**: 1007–1018.
- JINKS-ROBERTSON, S., M. MICHELITCH and S. RAMCHARAN, 1993 Substrate length requirements for efficient mitotic recombination in *Saccharomyces cerevisiae*. *Mol. Cell. Biol.* **13**: 3937–3950.
- KIM, J. M., 1996 Organization of Ty retrotransposons in the *Saccharomyces cerevisiae* genome. M.S. Thesis. Iowa State University, Ames, IA.
- KNIGHT, S. A. B., S. LABBE, L. F. KWON, D. J. KOSMAN and D. J. THIELE, 1996 A widespread transposable element masks expression of a yeast copper transport gene. *Genes Dev.* **10**: 1917–1929.
- LAURENSEN, P., and J. RINE, 1992 Silencers, silencing, and heritable transcriptional states. *Microbiol. Rev.* **56**: 543–560.
- LEVIS, R. W., R. GANESAN, K. HOUTCHENS, L. A. TOLAR and F. M. SHEEN, 1993 Transposons in place of telomeric repeats at a *Drosophila* telomere. *Cell* **75**: 1083–1093.
- LISKAY, R. M., A. LETSOU and J. L. STACHELEK, 1987 Homology requirement for efficient gene conversion between duplicated chromosomal sequences in mammalian cells. *Genetics* **115**: 161–167.
- LOUIS, E. J., 1995 The chromosome ends of *Saccharomyces cerevisiae*. *Yeast* **11**: 1553–1573.
- LOUIS, E. J., and J. E. HABER, 1992 The structure and evolution of subtelomeric Y' repeats in *Saccharomyces cerevisiae*. *Genetics* **131**: 559–574.
- LUNDBLAD, V., and E. H. BLACKBURN, 1993 An alternative pathway for yeast telomere maintenance rescues *essential*-senescence. *Cell* **73**: 347–360.
- MAESTRE, J., T. TCHENIO, O. DHELLIN and T. HEIDMANN, 1995 mRNA retroposition in human cells: processed pseudogene formation. *EMBO J.* **14**: 6333–6338.
- MAHONEY, D. J., and J. R. BROACH, 1989 The *HML* mating-type cassette of *Saccharomyces cerevisiae* is regulated by two separate but functionally equivalent silencers. *Mol. Cell. Biol.* **9**: 4621–4630.
- MELAMED, C., Y. NEVO and M. KUPIEC, 1992 Involvement of cDNA in homologous recombination between Ty elements in *Saccharomyces cerevisiae*. *Mol. Cell. Biol.* **12**: 1613–1620.
- MOORE, J. K., and J. E. HABER, 1996 Capture of retrotransposon DNA at the sites of chromosomal double-strand breaks. *Nature* **383**: 644–646.
- NEVO-CASPI, Y., and M. KUPIEC, 1994 Transcriptional induction of Ty recombination in yeast. *Proc. Natl. Acad. Sci. USA* **91**: 12711–12715.
- NEVO-CASPI, Y., and M. KUPIEC, 1996 Induction of Ty recombination in yeast by cDNA and transcription: role of the *RAD1* and *RAD52* genes. *Genetics* **144**: 947–955.
- RUBNITZ, J., and S. SUBRAMANI, 1984 The minimum amount of homology required for homologous recombination in mammalian cells. *Mol. Cell. Biol.* **4**: 2253–2258.
- SELVA, E. M., L. NEW, G. F. CROUSE and R. S. LAHUE, 1995 Mismatch correction acts as a barrier to homologous recombination in *Saccharomyces cerevisiae*. *Genetics* **139**: 1175–1188.
- SHARON, G., T. J. BURKETT and D. J. GARFINKEL, 1994 Efficient homologous recombination of Ty1 element cDNA when integration is blocked. *Mol. Cell. Biol.* **14**: 6540–6551.
- SHEN, P., and H. V. HUANG, 1986 Homologous recombination in *Escherichia coli*: dependence on substrate length and homology. *Genetics* **112**: 441–457.
- SIKORSKI, R. S., and P. HIETER, 1989 A system of shuttle vectors and yeast host strains designed for efficient manipulation of DNA in *Saccharomyces cerevisiae*. *Genetics* **122**: 19–27.
- SUGAWARA, N., and J. E. HABER, 1992 Characterization of double-strand break-induced recombination: homology requirements and single-stranded DNA formation. *Mol. Cell. Biol.* **12**: 563–575.
- SUGAWARA, N., E. L. IVANOV, J. FISHMAN-LOBELL, B. L. RAY, X. WU *et al.*, 1995 DNA structure-dependent requirements for yeast *RAD* genes in gene conversion. *Nature* **373**: 84–86.
- TCHENIO, T., E. SEGAL-BENDIRDJIAN and T. HEIDMANN, 1993 Generation of processed pseudogenes in murine cells. *EMBO J.* **12**: 1487–1497.
- TENG, S., B. KIM and A. GABRIEL, 1996 Retrotransposon reverse-transcriptase-mediated repair of chromosomal breaks. *Nature* **383**: 641–644.
- WEINSTOCK, K. G., M. F. MASTRANGELO, T. J. BURKETT, D. J. GARFINKEL and J. N. STRATHERN, 1990 Multimeric arrays of the yeast retrotransposon Ty. *Mol. Cell. Biol.* **10**: 2882–2892.
- WHITE, S. E., L. F. HABERA and S. R. WESSLER, 1994 Retrotransposons in the flanking regions of normal plant genes: a role for *copia*-like elements in the evolution of gene structure and expression. *Proc. Natl. Acad. Sci. USA* **91**: 11792–11796.
- ZOU, S., and D. F. VOYTAS, 1997 Silent chromatin determines target preference of the retrotransposon Ty5. *Proc. Natl. Acad. Sci. USA* **94**: 7412–7416.
- ZOU, S., D. A. WRIGHT and D. F. VOYTAS, 1995 The *Saccharomyces* Ty5 retrotransposon family is associated with origins of DNA replication at the telomeres and the silent mating locus *HMR*. *Proc. Natl. Acad. Sci. USA* **92**: 920–924.
- ZOU, S., N. KE, J. M. KIM and D. F. VOYTAS, 1996a The *Saccharomyces* retrotransposon Ty5 integrates preferentially into regions of silent chromatin at the telomeres and mating loci. *Genes Dev.* **10**: 634–645.
- ZOU, S., J. M. KIM and D. F. VOYTAS, 1996b The *Saccharomyces* retrotransposon Ty5 influences the organization of chromosome ends. *Nucleic Acids Res.* **24**: 4825–4831.

Communicating editor: L. S. SYMINGTON