

PARTHENOGENESIS IN DROSOPHILA

HARRISON D. STALKER¹

Department of Zoology, Washington University, St. Louis 5, Missouri

Received April 27, 1953

PARTHENOGENESIS, although well known in the lower Diptera, e.g., *Miastor*, has been rather infrequently reported, and apparently never analyzed, in the Acalypteratae. Thus the discovery of facultative parthenogenesis in several species of the genus *Drosophila* (STALKER 1951, 1952) seems of sufficient interest to report in some detail, especially as members of this genus have been so much studied in regard to their genetics and evolution.

Previous records of Acalypterate parthenogenesis involve the two families Othiphilidae (STURTEVANT 1923), and Agromyzidae (HERING 1926; FRICK 1951). In addition STURTEVANT (1923) has given evidence for parthenogenesis in the family Lonchopteridae (Brachycera). Many additional cases of parthenogenesis in other orders of insects are cited by SUOMALAINEN (1950) in his general review of parthenogenesis in animals.

MATERIALS AND METHODS

Most of the work to be reported in this paper was done with strains of *Drosophila parthenogenetica* STALKER originally derived from a single strain established by the University of Texas workers from a collection made in Atlixco, Mexico (PATTERSON and MAINLAND 1944) and generously supplied by the Texas laboratory. The specimens of *Drosophila polymorpha* used were derived from a Brazilian strain supplied through the kindness of DR. TH. DOBZHANSKY. Both of the above forms belong to the *D. cardini* species group.

In the measurements of rates of parthenogenesis reported in this paper, the virgin females were kept, either singly or in groups, in vials with standard cornmeal-Karo-agar-Moldex food medium. All work was done at 25°C unless otherwise indicated. The virgin females were transferred to fresh food vials every day, or in some cases every second day. The vials from which the females had been transferred were examined under a dissecting microscope daily up to and including the fourth day after oviposition. In these examinations the numbers of dead embryos and inviable larvae, the numbers of viable larvae, and the numbers of apparently undeveloped eggs were recorded.

The dead embryos were detected by the discoloration associated with their decomposition. When the typically mottled-looking brownish-black eggs were discovered they were in most cases removed, cleaned of food, crushed under a coverslip in saline and examined under high power with a compound micro-

¹ These studies were aided by a contract between the Office of Naval Research, Department of the Navy and Washington University (NR 164 10). Additional support was received from the Rockefeller Foundation and Washington University.

scope. In only one case out of over a thousand brownish eggs so examined was there no indication of any larval structure such as mouth hooks, gut lining, tracheal tubes or segmental hooklets. This method of detecting early embryonic development would of course result in the missing of those cases in which embryonic development was terminated very early, or in which no discoloration occurred, and should thus give an underestimate rather than an overestimate of the frequency of embryonic development.

When impaternal larvae were detected they were classified as viable or inviable on the basis of their appearance, this classification being checked in later examinations, and corrected if necessary. With a little experience there was no difficulty in making an accurate classification at the time the larvae were first detected. The inviable larvae typically showed enlarged mouth hooks and/or anterior region, and did very little active feeding; they displayed a great deal of slow wandering around, often leaving the choicest food (the yeast). The viable larvae on the other hand fed actively and almost constantly, and tended to remain in the region of the yeast droplet.

The mature (viable) larvae of both *D. parthenogenetica* and *D. polymorpha* have the distressing habit of leaving the food and pupating in the cotton plug of the vial, where they generally dry out. This difficulty may be partially overcome by the use of secondary plugs of cleansing tissue inserted in the vial well below the cotton plug. However, even the use of such a secondary plug will usually not save all of the larvae from self-destruction, and for this reason a count of viable larvae usually gives a better indication of fertility in vials than does the number of adults finally produced.

THE PROBLEM

Parthenogenesis in *Drosophila* was first discovered in a strain of *D. parthenogenetica*, which at that time was incorrectly classified as *D. neocardini* and has since been described (STALKER 1953). Crosses between *D. parthenogenetica* females and males of other species of the *D. cardini* species group resulted in the production of daughters which were morphologically, chromosomally and physiologically identical with their mothers. Further tests with virgin *D. parthenogenetica* females showed that parthenogenesis rather than hybridization was involved.

A number of questions then arose: 1. Did the production of diploid progeny by diploid virgins involve ameiotic chromosomal behavior with no chromosome reduction, or was there some type of meiosis with reconstitution of the diploid chromosome complement? 2. Although the percentage of unfertilized eggs completing development was less than 1.0, was it possible that intraspecific or interspecific matings might markedly increase this percentage? 3. Was it possible that suitable environmental conditions might bring about an increase in the frequency of parthenogenetic development? 4. Would continued selection for parthenogenetic development bring about an appreciable increase in its frequency? 5. Was facultative parthenogenetic development really a widespread phenomenon in *Drosophila* which had been hitherto over-

looked because of the low percentage frequency of development of unfertilized eggs? 6. What is the adaptive value, if any, of facultative diploid parthenogenesis in *Drosophila*? It was in an attempt to answer these questions that the experiments reported below were conducted.

Any effort to determine the chromosomal behavior in unfertilized eggs had, for practical reasons, to be directed along genetical lines, since direct cytological study of the unfertilized eggs was impractical due to the small number actually completing normal development. Thus at the outset efforts were made to obtain at least one mutant gene of which the transmission could be studied as an indication of chromosomal behavior. X-ray treatment of *D. parthenogenetica* females with 4000r units was followed by the discovery of a sex-linked recessive mutant gene, *g*, "garnet." Garnet flies are easily separable from wild-type, show rapid development and are little reduced in viability.

THE PROGENY OF DIPLOID VIRGINS

Table 1 shows the progeny of a selected strain of diploid females which have now been maintained without males for thirty-one consecutive generations. This strain was carried in vials for the first seventeen generations, and during this period nearly all of the diploid females produced in each generation were

TABLE 1

Progeny of diploid virgins of D. parthenogenetica; unisexual strain, generations 6 through 14. Progeny reared in vials.

Generation	Total progeny	% Diploid females	% Triploid females	% Diploid males	% 2n-3n Mosaic females
6	62	62.90	32.26	1.61	3.23
7	339	73.75	25.66	0.59	0.00
8	486	72.84	25.72	1.23	0.00
9	622	70.58	27.17	1.77	0.48
10	421	76.01	20.43	2.14	1.19
11	734	72.48	24.80	1.63	0.95
12	744	77.96	20.56	0.67	0.81
13	548	73.54	23.18	2.74	0.36
14	1182	78.34	20.05	1.43	0.17
Totals	5138	74.80*	23.10**	1.50***	0.53****

*Of the diploid females, 0.39% showed abnormal abdomen, 0.03% were 5-legged, and 0.03% were Minute.

**Of the triploid females, 6.82% showed abnormal abdomen, 1.18% were 5-legged, and 0.08% were 7-legged.

***Of the diploid males, 1.30% were 5-legged.

****Two diploid-triploid mosaics were found which were apparently diploid-male, triploid-female sex-mosaics. In addition to the types listed in the table, three polyploid intersexes were found which, on the basis of the wing-cell size were considered to be 2X 3A intersexes.

used as the parents of the next. Since the seventeenth generation the strain has been carried in standard half-pint culture bottles, with about 400 diploid females used as parents in each generation. The data in the table cover the progeny produced in generations six through fourteen. It will be noted from this table that for the nine generations shown there is very little change in the frequency of the four types of progeny. About 1.5% of the progeny are diploid males. These males are sterile, as expected, and cytological analysis of the testes has shown them to be XO rather than XY. The diploid and triploid females are readily distinguished by the spacing and size of the hairs on the wing blade. Since each hair is derived from a single cell, a count of the number of hairs per unit space gives the cell size and hence indicates whether diploidy or polyploidy is present (DOBZHANSKY 1929). Cytological examination of the ovaries of eleven females which, by their wings were clearly polyploid established that they were *triploid*, not tetraploid. Using the cell size of the wings in these proven triploid females as a guide, counts were made of the wings of forty-two more polyploid females, and these agreed so well with the cell size of the original eleven females that there was no doubt that they too were triploid. No clearly tetraploid females have been found so far among the progeny of diploid virgins.

In order to establish the fact that triploidy in this species is definitely associated with parthenogenesis rather than an independent characteristic of the strain, twenty-three females from the eighth generation of the unisexual strain were mated to males of the unselected bisexual strain, the larvae reared in uncrowded bottles and the emergent adults checked for polyploidy by examination of the wings. Out of the 2,736 females and 2,182 males so checked all were diploid. Thus the diploid females of the unisexual strain regularly produce triploid progeny only from unfertilized eggs.

Approximately one-half of one percent of the progeny of diploid virgins were clearly diploid-polyploid mosaics. In one of these mosaic females one ovary was shown cytologically to be triploid, the other diploid. Comparison of the wings of the other mosaic individuals with those of cytologically proven triploids showed that the polyploid patches were clearly triploid, not tetraploid. The *observed* frequency of such mosaics is probably lower than the frequency with which they are produced, since although a mosaic in which one wing is diploid and the other triploid could scarcely be overlooked, in some cases one wing was either diploid or triploid, and the other mosaic, and some of these latter cases were undoubtedly missed.

As indicated in the footnotes to table 1, abnormal abdomen and the absence of one of the metathoracic legs occurred in both diploid and triploid females, but was much commoner in the latter. The seven-legged triploid female showed a complete duplication (mirror-image) of one metathoracic leg, the duplication beginning with the coxa.

In each generation of the unisexual diploid strain, starting with the progeny of generation six, the triploid virgins were separated and allowed to reproduce. Table 2 shows the progeny so produced.

TABLE 2

Progeny of triploid virgins of D. parthenogenetica; unisexual strain, generations 7 through 15. In each generation the triploid mothers were derived from diploids. Thus each generation of progeny shown in this table are second generation derivatives of the unisexual diploid line. Progeny reared in vials.

Generation	Total progeny	% Diploid females	% Triploid females	% Diploid males	% 2n-3n Mosaic females
7-8	174	25.86	27.01	47.13	0.00
9-11	300	27.67	29.67	41.67	0.33
12	343	32.65	25.07	41.69	0.29
13	293	32.42	29.35	37.54	0.68
14	262	22.14	37.02	39.31	0.38
15	428	29.44	29.91	39.02	0.70
Total	1800	28.83*	29.61 [#]	40.56**	0.44***

*Of the diploid females, 1.16% showed abnormal abdomen, 0.77% were Minute and 0.19% were 5-legged.

[#]Of the triploid females, 3.94% showed abnormal abdomen and 1.69% were 5-legged.

**Of the diploid males, 5.21% were Minute.

***Two diploid-triploid mosaics were found which were apparently diploid-male, triploid-female sex mosaics.

It will be noted from this table that the frequencies of the various types of progeny of triploid virgins are strikingly different from those derived from diploids. This difference involves principally a change in the frequencies of diploid XO males and diploid females. While diploid males are rarely produced by diploid virgins, they constitute over 40% of the progeny of triploids. These diploid males were also XO and sterile. The diploid and triploid progeny showed the same disparity in the frequency of abnormal abdomen and the five-legged condition as that shown for the diploids and triploids in table 1.

Table 3 lists the progeny obtained from virgin diploid females heterozy-

TABLE 3

Progeny of heterozygous garnet (+/g) virgin females obtained by crosses of homozygous wild-type females × garnet males.

	Diploid males	Diploid females	Triploid females	2n-3n Mosaic females
Wild-type	6	1,284*	172**	5
Garnet	7	279	0	1

*42 of these diploid wild-type females were analyzed by crosses to fertile garnet males. Of these 42, 10 were homozygous wild type, 32 were heterozygous for garnet. Thus the corrected estimates for the three genotypes would be: g/g 17.9%; +/g 62.6%; +/+ 19.6%.

**65 triploid wild-type females were analyzed by crosses to fertile garnet males. Of these, 64/65 were either +/+g or +/g/g. 1/65 may have been +/+/. Such a +/+ triploid female could have arisen from an homozygous wild-type impatentate virgin female.

gous for the sex-linked recessive eye-color, garnet (*g*). It will be noted that among the diploid female progeny, heterozygotes and both types of homozygotes appear, with about 63% heterozygotes and 37% homozygotes. Among the triploid female progeny no homozygous garnet individuals appeared. On the basis of these data alone it might be supposed that perhaps the absence of garnet triploid females among the progeny was due to their reduced viability. However, garnet triploids have been produced in quantity in other crosses and show about 80% viability as compared to wild-type triploids. Of the 172 triploid females produced, 65 were tested by crossing them to garnet males, and 64/65 were shown to carry at least one garnet gene, and thus were either $+/g/g$ or $+/+g$. The one triploid female which when tested gave no indication that it carried a garnet gene, and was thus $+/++$, may have arisen from an impaternate homozygous wild-type diploid mother, since the heterozygous garnet diploid virgins used as parents were produced by crosses of homozygous wild-type females \times garnet males, and any unfertilized eggs which completed development could have produced homozygous wild-type diploid females. The production of $+/g$ virgins by the reciprocal cross was not practical since no bisexual strain showing a sufficiently high rate of parthenogenesis was available.

The above data give some very important clues regarding the meiotic mechanism in unfertilized eggs, and before presenting more data a partial analysis will be made.

To begin with, it is clear that in the production of progeny from unfertilized eggs in *D. parthenogenetica*, some meiotic mechanism is involved, rather than an ameiotic maturation of the egg in which there is no chromosome reduction and hence no need for reconstitution. This conclusion is based on several facts: First, diploid virgins produce not only diploid daughters like themselves, but triploid daughters as well. If the egg maturation were ameiotic, only diploids (and possibly tetraploids) should be produced. Secondly, heterozygous garnet diploid virgins produce not only heterozygous daughters like themselves, but large numbers of both types of homozygotes. Thus genetic recombination is occurring, requiring some sort of meiotic phenomenon.

In those forms in which partheno-produced individuals have a zygoïd (diploid or polyploid) number of chromosomes, SUOMALAINEN (1950) distinguished two general kinds of parthenogenetic mechanisms, as follows:

"1. Automictic parthenogenesis or parthenogamy. Regular chromosome conjugation and reduction occur in the eggs developing parthenogenetically. The zygoïd chromosome number is restored through the fusion of two azygoïd nuclei, the formation of a restitution nucleus or endomitosis. This corresponds to WHITE'S (1945) meiotic parthenogenesis.

"2. Apomictic parthenogenesis. Neither chromosome reduction nor fusion of nuclei nor any corresponding phenomenon . . . takes place in the eggs developing parthenogenetically. This type corresponds to the somatic parthenogenesis of WINKLER and ANKEL and the ameiotic parthenogenesis of WHITE (1945)."

It appears then that *D. parthenogenetica*, having occasional diploid parthenogenesis associated with a meiotic mechanism would be classified as a facultative automictic.

The various types of automictic parthenogenesis are reviewed by SUOMALAINEN (1950) and will be considered here only insofar as they are directly concerned with the argument.

In some automictic forms (e.g., the Psychid moth, *Apterona helix*) the first meiotic division proceeds normally, but both second division metaphase plates fuse to form a single metaphase plate, the second division then resulting in the formation of two diploid nuclei, both of which function as cleavage nuclei. In this type of parthenogenesis it will be noted that there is no formation of non-functional polar nuclei, and hence no elimination of genes between the onset of meiosis and the first cleavage divisions. Thus a female heterozygous for garnet could not produce either homozygous garnet or homozygous wild-type progeny. Moreover if there were post-reduction of the garnet gene in this type of meiosis (and this might be expected, at least part of the time), then the two diploid nuclei formed at the end of meiosis could be homozygous garnet in the one case and homozygous for the wild allele in the other, and a garnet mosaic should be formed. Actually among the 1,563 diploid daughters of heterozygous garnet virgins no mosaics for garnet have been found. Finally, the type of meiosis found in *Apterona helix* would not, without special modifications, account for the observed production of 23% triploid females from diploid virgins. Thus it is clear that any meiotic mechanism of this type simply cannot explain the facts.

Another type of automictic parthenogenesis (e.g., in the gall wasp, *Neuroterus baccarum*) involves an abortive first meiotic division with the result that only one nucleus is formed rather than two, followed by a second division resulting in the formation of two nuclei, both diploid and both functioning as cleavage nuclei. Genetically the results of such meiotic behavior in heterozygous garnet diploid females would be the production of either heterozygous or garnet-mosaic diploids. Thus for the reasons outlined above in relation to *Apterona helix* this type of meiotic behavior cannot explain the known facts.

A variation of the meiotic behavior of the two forms described above involves an abnormal first meiotic division, followed by a second division and the formation of two diploid nuclei, but with only one of these nuclei functioning as the cleavage nucleus, the other being eliminated as the polar nucleus (e.g., the moth *Solenobia lichenella* and the parasitic wasp *Nemeritis canescens*). Genetically the results of this chromosomal behavior would be that an heterozygous garnet female could produce either homozygotes or heterozygotes, the proportions depending on the amount of crossing over between the locus of garnet and the X-chromosome centromere, i.e., on the relative frequencies of pre- and post-reduction of garnet or its wild-allele. However, this meiotic mechanism will still not explain the high production of triploids by diploid virgins.

All of the types of meiosis outlined above have resulted in the formation of diploid cleavage nuclei because of abnormalities in the meiotic mechanism itself. However even with normal meiotic divisions diploidy may be reconstituted if the haploid cleavage nuclei fuse in pairs, forming diploid nuclei

(e.g., as in the moth *Solenobia triquetrella*). Such fusion of the cleavage nuclei could, if it involved three haploid cleavage nuclei rather than only two, result in the formation of triploids as well as diploids. However, an heterozygous garnet diploid virgin should then always produce homozygous progeny, since all of the cleavage nuclei, whether they fused in two's to form diploids, or three's to form triploids would all come from the same original haploid egg pronucleus. The fact that the diploid progeny of heterozygous diploid virgins are either heterozygous or homozygous, and the fact that the triploid progeny of heterozygous diploid virgins are never homozygous garnet nor (probably) homozygous for its wild allele, both effectively eliminate the possibility that this type of chromosomal behavior could occur regularly in *D. parthenogenetica*.

One final way in which meiosis might be perfectly normal, with the formation of an haploid egg pronucleus and three haploid polar nuclei, involves a fusion of either the egg pronucleus with one of the polar nuclei, forming a diploid first-cleavage nucleus, (e.g., as in the coccid *Lecanium hesperidum*), or possibly the fusion of two polar nuclei (the egg pronucleus and one polar nucleus being eliminated in cleavage). Similarly, fusion of three of the four haploid nuclei would result in the production of a triploid first-cleavage nucleus.

It will be noted that of all these types of meiosis which are known to occur in various parthenogenetic animals, only one type, the last, could, with some modifications, account for the findings in *D. parthenogenetica*.

We will provisionally assume that this last type of meiotic behavior is the one occurring in *D. parthenogenetica*, and consider in some detail how well the available data fit such an assumption.

First, let us consider the commonest types of progeny of the diploid virgins. These are: diploid females and triploid females. It will be noted from figure 1-a that fusion of any two of the haploid nuclear products of the second division will result in a diploid first-cleavage nucleus, while fusion of three haploid nuclei would result in a formation of triploids. Although cytological data on normal meiosis in *D. parthenogenetica* are lacking, studies of other Diptera, especially *Drosophila* indicate that such fusion of the haploid second division products is the rule in normal meiosis of *fertilized* eggs. Thus, in *Sciara*, CARSON (1946) finds fusion of the two median nuclei to form a diploid nucleus. This diploid nucleus and the terminal nucleus (one of the first polar bodies) then migrate to the posterior end of the egg and do not take part in further development. In *D. melanogaster*, HUETTNER (1924) has shown that following fertilization and the completion of meiosis there is fusion of the two inner polar nuclei to form a diploid nucleus, followed by a fusion of this nucleus with the remaining polar nucleus to form a triploid nucleus, the triploid nucleus so formed from the three polar nuclei eventually disintegrating. ФАХМУ (1952) has studied meiosis in fertilized eggs of *D. subobscura*, in which he finds that following the second meiotic division there is regularly fusion of the two inner polar nuclei to form a diploid nucleus, and that this is followed by fusion with the remaining polar nucleus to form a triploid nucleus which persists without

further division into late cleavage. Thus it would appear that the normally occurring fusion of haploid polar nuclei in fertilized eggs of *Drosophila*, and probably many other Diptera as well, furnishes a ready-made mechanism which might under certain circumstances "take over" in the development of unfertilized eggs, and result in the production of the diploids and triploids so common among the progeny of virgin *D. parthenogenetica*.

It will be noted that about 1.5% of the progeny of diploid virgins are XO sterile diploid males. Such males would require some irregularity in the meiotic mechanism, and it is suggested that non-disjunction of the X-chromosome in the second meiotic division would give such a result if, as indicated in figure 1-b fusion were between the two median polar nuclei. Such non-disjunction might also result in the production of triploid intersexes (fig. 1-b).

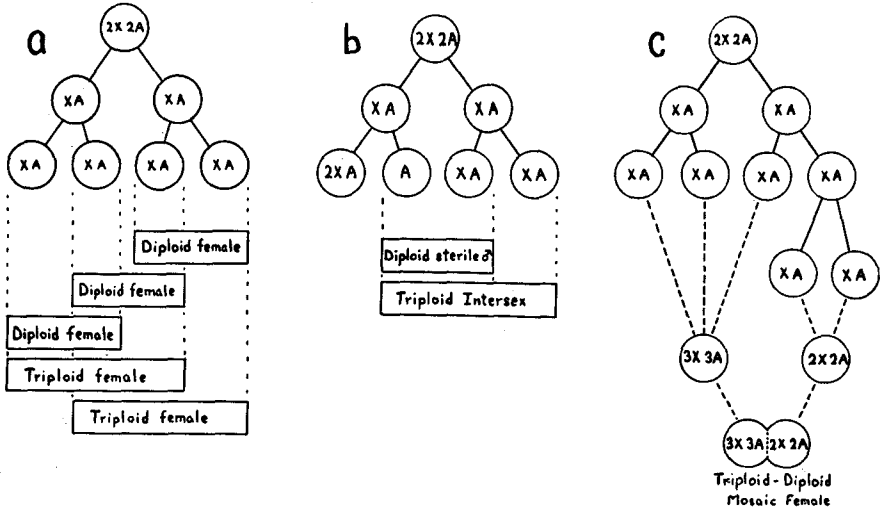

FIGURE 1.—Types of progeny which may be produced by various patterns of nuclear fusions in the eggs of diploid virgin females. In each diagram the four circles in the third row represent the four nuclei formed after the second meiotic division. See text.

Individuals which were clearly sub-triploid on the basis of wing-hair counts, and were intersexual in their internal genitalia have been observed. If, instead of the terminal nucleus containing two X chromosomes, one of the median nuclei did so, then a median fusion of two polar nuclei would result in the production of $3X2A$ superfemales. A few females have been observed which on the basis of morphology may have been superfemales but no satisfactory chromosome counts have ever been obtained from their ovaries.

In the case of the 0.5% diploid-triploid mosaics produced by diploid virgins a somewhat more complicated explanation is required. Probably the simplest is that shown in figure 1-c. This involves mitotic division of one of the four haploid nuclei prior to fusion, fusion of two of the haploid nuclei so produced to form a diploid nucleus, and this diploid nucleus plus a triploid nucleus formed by a simple three-way fusion both functioning as cleavage nuclei, thus forming a diploid-triploid mosaic.

If this is the correct explanation, then the diploid tissue might be $+/+$ or g/g while the triploid tissue would always be phenotypically wild-type ($+/+g$ or $+/g/g$). Thus some garnet diploid-wild-type triploid mosaics might occur. Only six ploid mosaics have been produced by $+/g$ diploid virgins and none of these was mosaic for eye-color.

It will be noted from table 2 that triploid virgins produce a very high proportion of triploid and diploid daughters. In figure 2 are shown only those types of triploid meiosis involving segregation of complete haploid sets of autosomes. It will be noted that regardless of the relative segregation of autosomes and X-chromosomes, a two-nucleus median fusion will always result in the formation of a triploid cleavage nucleus. This is true even if the autosomes do not assort as complete haploid sets. Figure 2-a shows two ways in which diploid females might be produced; either by fusion of two haploid

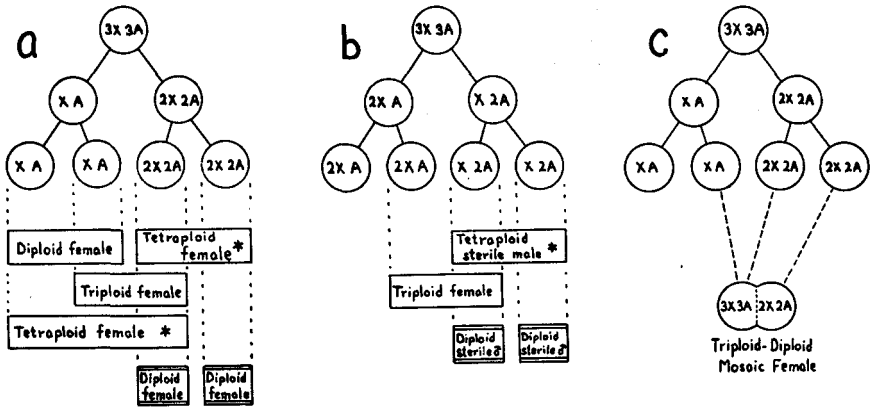

FIGURE 2.—Types of progeny which may be produced by various patterns of nuclear fusions in the eggs of triploid virgin females. In each diagram the four circles in the third row represent the four nuclei formed after the second meiotic division. Types of progeny marked with an asterisk have not been observed. See text.

nuclei, or by direct development without fusion of one of the two remaining diploid nuclei.

The most frequent type of progeny of the triploid virgins is the diploid XO sterile male. In the absence of extraordinary assumptions concerning non-disjunction of X-chromosomes or autosomes, this large number of diploid males could only be produced by direct development, without fusion, from the X2A nuclei, as shown in figure 2-b. This apparent necessity for development without fusion to account for the production of diploid males, makes it highly probable that a certain proportion of diploid females are produced in the same way, as shown in figure 2-a. Whether in such cases the individuals so produced are actually mosaics, with both diploid nuclei functioning in cleavage, or whether one nucleus functions, the other taking no part in development, is not known.

Theoretically this point could be settled by a study of the progeny of $+/+g$ or $+/g/g$ triploid females. With post-reduction of the garnet gene, diploid

males and females might be garnet mosaics if they developed from two unfused diploid nuclei rather than one. Unfortunately all of the several hundred triploid females that have been of the required genotype have proved to be so sterile as virgins that only 24 diploid progeny have been produced by them altogether. Since none of these progeny was garnet mosaic, the question remains unanswered, especially so since it is not possible to predict with any accuracy the relative frequencies of pre- and post-reduction of the garnet gene. At least it may be said that at present there is no evidence for such mosaic origin from unfused nuclei.

It is worth mentioning at this point that BRIDGES (see BRIDGES and ANDERSON 1925) has shown that in triploid females of *D. melanogaster*, meiosis of the type shown in figure 2-b of this paper is much commoner than the alternate type 2-a. If this finding applies also to *D. parthenogenetica* it may well explain the relatively high proportion of diploid males to diploid females among the progeny of triploid virgins.

Fusions of the types shown in figures 2-a and 2-b should result in the formation of both tetraploid males and females. Such males and females have not been found, which suggests that they are low in viability or very rare.

The triploid-diploid mosaic females which make up about one-half of one percent of the progeny of triploid virgins may be accounted for by three of the four nuclei taking part in cleavage, but the two median nuclei forming a triploid cleavage nucleus, the outer diploid nucleus cleaving without fusion, as in figure 2-c.

The three diploid-triploid sex-mosaics (listed in the footnote of table 2) could be produced by the same type of chromosomal behavior, starting with the X-autosomal distribution of the type shown in figure 2-b. Here fusion of the two median nuclei would provide the triploid cleavage nucleus, the outer X2A unfused nucleus would supply the male cleavage nucleus, thus leading to a female-triploid male-diploid mosaic.

THE FUSION PATTERN IN DIPLOIDS

The evidence given above indicates that in the production of diploid daughters by diploid virgins two of the four haploid second division products fuse, to form the diploid first-cleavage nucleus. Which particular nuclei take part in such fusion is of considerable interest. In *Drosophila* the termination of the second division leaves the nuclei temporarily in a straight line extending perpendicularly from the periphery of the egg, and there is indirect evidence that at least some of the two-nucleus fusions must involve the two median nuclei. This is based on the fact that in triploid virgins a high proportion of the progeny are triploid daughters. Such daughters would always be formed by fusion of the two median nuclei, regardless of how the sex chromosomes and autosomes segregated in the first division, and apparently there is no other way in which triploids could be formed from triploid mothers (see fig. 2-a, 2-b). Thus, in the eggs from triploid females at least, the evidence is very strong that median fusions of the second division products do

occur. This still leaves the question of terminal fusions, such as might occur between the egg pronucleus and the nearest polar nucleus, or between two terminal polar nuclei. Of course in the formation of triploids from diploids (fig. 2-a), it is presumed that both median and terminal fusions occur, but otherwise there is no class of offspring which has been observed from either diploid or triploid virgins which would *require* terminal fusion alone. Which particular nuclei take part in fusions might be determined genetically by following the transmission of a gene located so close to a centromere that there was little or no crossing-over. In the absence of such a gene, some information may be obtained by the behavior of the Y chromosome in XXY females. Such females were obtained by crossing triploid garnet females to wild-type males. The resulting diploid garnet daughters should, unless they were impaternal, then receive both X-chromosomes from the mother and a Y-chromosome from the father. A number of such females were allowed to reproduce as virgins, but for reasons imperfectly understood only two of them produced enough

TABLE 4
*The chromosomally different types of progeny produced
by virgin XXY diploid females.*

Chromosomal constitution	No.	Fusion pattern*
Diploid XX	3	Terminal
Diploid XX-YY	2	Terminal
Diploid XX-Y	12	Median
Triploid XXX-Y	4	
Triploid XXX-YY	2	

*See text for explanation.

progeny to indicate with certainty that they were XXY, and not XX impaternal. The metaphase chromosomes of the impaternal progeny of these two females were studied by making acetic-orcein smears of the larval neuroblasts. In the metaphase chromosomes of *D. parthenogenetica* the X-chromosome is a long rod with a satellite. The Y is a large, approximately equal-armed V-shaped chromosome, the autosomes consist of a large pair and a small pair of V-shaped chromosomes and a pair of dots. The distinctive size and shape of the sex-chromosomes thus makes analysis of the metaphase plates relatively easy. Table 4 lists the chromosomally different types of progeny produced. Since the triploid XXX-Y and XXX-YY females are derived from combined median and terminal fusions they are of no value in determining the fusion pattern and will not be considered further.

In interpreting the diploid progeny an assumption must be made. The assumption is that in XXY females the sex chromosomes show pre-reduction, as they would be expected to do in an XY diploid male. There appears to be no good reason for believing that there should *not* be pre-reduction, but with the genetic material at hand in this species this point cannot be readily settled.

With pre-reduction of the sex chromosomes the first and second divisions might proceed along either of the paths indicated below:

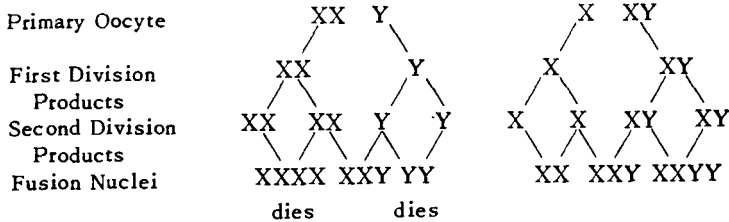

It will be noted that regardless of the pattern of non-disjunction, fusion of the two median nuclei will always result in XXY females, while fusion of two terminal nuclei will result in death (XXXX and YY classes), or in XX or XXYY individuals. Thus all of the living diploid females produced may be classified as having arisen from median or terminal nuclear fusions. The data in table 4 indicate that the fusions may arise by either path, 12/17 of the cases coming from median fusions, 5/17 cases coming from terminal fusions. Since approximately one-half of the terminal fusions should lead to the production of inviable karyotypes, the limited data available would suggest that median and terminal fusions are about equally frequent.

PARTHENOGENETIC DEVELOPMENT IN OTHER DROSOPHILIDAE

The finding of parthenogenesis in *D. parthenogenetica* has drawn attention to the possibility that such unusual reproductive behavior might occur in other related species, or for that matter in any other Drosophiline. Even in genetically well-investigated species rare parthenogenetic development might be overlooked, especially if it regularly terminated with death in embryonic or early larval life.

In order to investigate this possibility, virgin females of twenty-seven additional species of Drosophilidae were maintained throughout life in vials without males, the eggs they produced being examined under a dissecting microscope every day, or in some instances every other day up to and including the fourth day after oviposition. By this procedure it was possible not only to identify impaternal larvae when they were produced, but also in many instances to observe embryos which had died prior to hatching.

In those cases where larvae appeared they were at once transferred to fresh food along with some of the yeast in which they were found, and re-transferred as often as necessary to keep down mold and bacterial growth.

The results of this survey are summarized in table 5. The total numbers of eggs examined (listed in the second column), are approximations based on actual counts of the numbers of eggs laid in every third vial through which the females were transferred. In the case of the figure "500,000" for *D. melanogaster*, this is an approximation based on the known egg production per female under crowded conditions in vials, multiplied by the number of females tested. It is probably an underestimate.

TABLE 5

Summary of rates of parthenogenetic development in various species of *Drosophilidae*. Rates for *D. parthenogenetica* are not included in this table. Members of the same species group are bracketed.

Species	Total unfertilized eggs examined	Total dead embryos	Total dead larvae	Adults
DROSOPHILA				
cardini #	52,850	3		
polymorpha #*	37,629	109		2
neocardini #	11,439	1		
cardinoides #	30,777	3		
acutilabella #	16,463	11		
campestris #	23,682	14		
acutilabella X cardinoides F ₁ hybrids #	6,231	1		
macrospina	2,655			
funebis	43,198	3		
melanica	5,199	1	1	
nigromelanica	5,243			
americana	18,165			
tripunctata	9,280	2		
mediostriata #	14,883	7		
robusta	10,706	2		
immigrans	8,153	1		
transversa	11,616	2		
quinaria	11,868	6		
putrida	8,431	4		
hydei	63,027	18	1	
HIRTODROSOPHILA				
duncani	16,044	1		
SOPHOPHORA				
melanogaster	32,197	1		
melanogaster**	500,000		2	
simulans	13,872	1		
affinis	19,059	4		1
PHOLADORIS				
victoria	1,292			
SCAPTOMYZA				
graminum	4,314	4		
adusta	2,340			
ZAPRIONUS				
vittiger #	10,167			

*Virgins from established laboratory stocks. In all other cases the virgins were F₁ or F₂ progeny of wild flies captured in the St. Louis, Missouri area.

*These figures are for the unselected bisexual strain. See table 8 also.

**Approximate number of eggs, oviposition in half-pint bottles, unfertilized eggs not examined for presence of dead embryos.

The first seven rows in the body of table 5 show the results for the other members of the species group to which *D. parthenogenetica* belongs (the *D. cardini* group). It will be noted that in each of the six species and in the hybrids some dead embryos were found. However, in only one species, *D. polymorpha*, were any adults produced, and in this case only two (diploid females), from about 37,000 eggs. These results for *D. polymorpha* are based on the performance of the unselected, bisexual Brazilian stock received from DR. TH. DOBZHANSKY. A selected strain derived from one of the two impaternal females shows a much higher rate of parthenogenesis, and is discussed later in the paper.

For the remaining species belonging to the subgenus *Drosophila*, ten out of the thirteen studied showed some parthenogenetic development terminated prior to hatching, and two species, *D. melanica* and *D. hydei* each produced a single impaternal larva which survived into the second larval instar.

In the subgenera *Hirtodrosophila* and *Sophophora* all four of the species tested gave positive results. It will be noted that in the case of *D. affinis* one impaternal adult was produced, which unfortunately was lost before it could be sexed. However, there was little doubt that the pupa from which this fly came belonged to the *D. affinis* group, as indicated by the structure of the pupa case and the coloration of the developing imago. The possibility that this individual was the result of contamination seems very remote as no stock of *D. affinis* or its relatives had been maintained in the laboratory for a period of six weeks prior to the emergence of this fly.

It will be noted that both *D. melanogaster* and *D. simulans* produced impaternal embryos. In the case of *D. melanogaster* the second entry in the table refers to a special test made of the first generation daughters of many wild caught flies. In this case none of the eggs were examined microscopically, although the bottles were frequently examined for the presence of larvae two of which were detected but which did not survive beyond the second instar.

Approximately half of these 500,000 eggs came from females mated to sterile males produced by the use of MULLER'S "sterilizer" stock, the others were produced by virgin females. These tests with *D. melanogaster* seem to indicate that, as has been concluded in the past, parthenogenesis in this species does not constitute a serious complication in genetic experimentation.

In the genera *Scaptomyza* and *Zaprionus* only one of the three species tested (*S. graminum*) showed parthenogenetic development. Thus of the twenty-seven species examined, two produced impaternal adults, three produced second instar larvae, fifteen produced only dead embryos, and five showed no indication of parthenogenetic development of any sort.

In no case was it possible to determine the chromosomal content of the developing embryos, since they were only discovered after they had died and decayed. In the case of the larvae dying in the second instar the condition of the tissue likewise prohibited cytological analysis. However, from the evidence given above in connection with *D. parthenogenetica*, it is assumed that in this case the death in the embryos and partly grown larvae was associated with haploidy.

FACTORS AFFECTING RATES OF PARTHENOGENESIS

1. *The genotype and the karyotype*

As explained above, in the species *D. parthenogenetica* the unisexual parthenogenetic strain was established in the summer of 1951 and has been maintained since that time, now being in its thirtieth generation. Of course in such a strain, with complete dependence on parthenogenetic reproduction any combination of genes favoring such reproduction would have a selective advantage, and would tend to be incorporated into the strain. Thus the rates of parthenogenesis in such a strain might be expected to show a gradual rise. Table 6 shows the rates for the unselected bisexual strain and for the second, ninth and seventeenth generations of the unisexual strain. It will be noted that the strain has improved itself in two ways. First, the frequency of eggs starting development has risen from 0.91% to 8.20%. Secondly, the *survival* of individuals which are known to have *begun* development has risen from 8.96% to about 20%. These two factors taken together have increased the production of viable impaternal progeny from 0.08% to 1.55%, or almost twenty-fold. It will be noted in this and later tables that instead of considering the percentage of eggs forming adults as an indication of fertility, the percentage forming viable larvae is used.

When the females of the unisexual strain are outcrossed to unselected bisexual strain males the F_1 virgins appear to show a fertility intermediate between that of the two parental strains, although no numerical data are available to prove this.

Several points should be mentioned with regard to the unisexual strain. First, although 250 to 300 females are used as parents in each generation, it is not known how many of them actually produce progeny under the rather competitive conditions of the culture bottles, and hence the strain may, and

TABLE 6
Rates of parthenogenesis among diploid and triploid virgins of D. parthenogenetica.

Source of virgins	Diploid virgins				Triploid virgins
	Bisexual strain	Unisexual Selected Strain			Unisexual strain
		Generation 2	Generation 9	Generation 17	
No. ♀♀ tested	218	82	69	42	54
Total eggs	74,538	20,751	17,740	12,464	11,234
Dead embryos	620	242	327	829	82
Larvae	61	64	66	193	19
% Eggs starting development	0.91	1.48	2.22	8.20	0.90
% Eggs forming viable larvae	0.08	0.31	0.37	1.55	0.17
% Survival among eggs starting development	8.96	20.92	16.79	18.88	18.81

probably does, consist of a group of very closely related individuals. Secondly, any genetic improvement in the reproductive performance of the strain due to recombination can only come from recombination of genetic variability *within* individuals, rather than *between* individuals, since there can be no mixing of the genotypes from any two individuals. Thirdly, the noted improvement in the fertility of the unisexual strain may be due to nuclear changes, cytoplasmic changes or both. The possible role of an infective or symbiotic agent as a promotor of parthenogenesis is under investigation.

The last column of table 6 shows the rates for triploid virgins derived from diploids of generations five and seven of the unisexual strain. Thus these triploids really represent the sixth and eighth generation of the strain, and may best be compared with the diploid virgins of the ninth generation. It will be noted that both the observed frequency of eggs known to start development and the percentage of eggs leading to the formation of viable larvae is lower than in the case of diploid females of the ninth generation.

The reasons for this are far from clear, however, since nothing is certainly known either of the frequencies of various types of chromosomal segregants, nor of the proportion of aneuploids which would develop far enough to be detected and classified as dead embryos.

The unisexual strain of D. polymorpha. Table 5 shows that in the unselected bisexual strain of *D. polymorpha* only two adults (diploid females) were produced. These two flies came from the same vial at the same time, and may well have come from the same mother. Of the two, one became accidentally stuck in the food; the other was tested as a virgin and of 693 unfertilized eggs 21.1% developed to the embryonic or early larval stage and died. Such a high proportion of eggs starting development has not been observed in any other case in this or any other species. However, despite the high proportion of eggs starting development, no viable larva were produced by this virgin. She was mated to normal XY ♂♂ from the unselected bisexual strain and a bisexual sub-strain established which was set aside for approximately a year. At the end of that period 52 virgin females from this sub-strain were tested and immediately produced an unisexual strain which has been maintained with relatively little difficulty since and is now in its ninth generation. Repeated attempts to establish a second unisexual strain from the original unselected bisexual strain have failed. This sequence of events seems to point to a rather abrupt genetic differentiation which caused a sudden rise in the rate of parthenogenesis. In *D. polymorpha* as in *D. parthenogenetica* both diploid and triploid females, as well as sterile XO males are produced by virgin diploid females, suggesting that the mechanism of parthenogenesis is the same in both species.

To summarize: It appears that both the genotype and the degree of ploidy may control intra-specific differences in the rate of parthenogenesis.

2. *The effect of female age on the rate of parthenogenesis*

Experience with the unisexual strain of *D. polymorpha* soon showed that the young virgins appeared to be less fertile than those two or three weeks

TABLE 7

Effect of female age on rate of parthenogenesis in D. parthenogenetica. The females reported in this table belonged to the 21st generation of the unisexual selected strain.

	Age of females in days						
	6-9	10-13	14-17	18-21	22-25	26-29	30-34
No. females tested	14	14	14	14	9	9	9
Total eggs	2,732	3,747	3,217	2,453	1,482	1,196	1,290
% Eggs starting development	7.28	8.14	5.38	6.77	8.43	5.18	8.29
% Eggs forming viable larvae	1.39	1.28	1.27	1.18	1.55	1.38	1.78
% Survival among eggs starting development	19.10	15.74	23.70	17.47	18.40	25.81	21.50

of age. This apparent effect of female age was accordingly tested in both *D. parthenogenetica* and *D. polymorpha*.

Table 7 gives the results for *D. parthenogenetica*. In this species fourteen virgins from the twenty-first unisexual generation were maintained separately in vials until they died. In the table the data from these fourteen females are lumped. Either considering the females as a group, or singly, they show no consistent change with age, either with regard to the percentage of eggs starting development, or for the percentage of eggs forming viable larvae.

In *D. polymorpha*, however (table 8), the proportion of eggs starting development and the proportion forming viable larvae rises until the third week of adult life; the increase in production of viable larvae being approximately twenty-fold. A consideration of the individual rates of the twenty females shows that there is a good deal of inter-female variability in the percentages of eggs producing viable larvae at different ages. In figure 3 the individual records are shown diagrammatically, with a single vertical bar for each female, the width of the bar indicating the percentage of eggs producing viable larvae

TABLE 8

Effect of female age on rate of parthenogenesis in D. polymorpha. The females reported in this table belonged to the 4th generation of the unisexual selected strain.

	Age of females in days						
	2-5	6-9	10-13	14-17	18-21	22-29	30-37
No. females tested	20	20	20	16	12	5	5
Total eggs	3,816	5,009	3,810	2,825	1,615	1,796	1,012
% Eggs starting development	0.26	1.04	2.05	3.89	5.57	3.29	0.49
% Eggs forming viable larvae	0.03	0.16	0.31	0.71	0.62	0.33	0.00
% Survival among eggs starting development	10.00	15.38	15.38	18.18	11.11	10.17	0.00

in a given age period. It will be noted from this figure that although there is much variability in life-length and fertility, very few young females produced any viable larvae, and for those that did, the percentage fertility was very low; while the older females were not only more frequently fertile, but showed a higher rate during their fertile periods.

The considerable inter-female variability in the viability and fertility of this unisexual strain of *D. polymorpha* may well be associated with strain heterozygosity for one or more deleterious genes, as approximately one-third of the females in the strain show abnormal drooping wings with the fifth longitudinal vein incomplete.

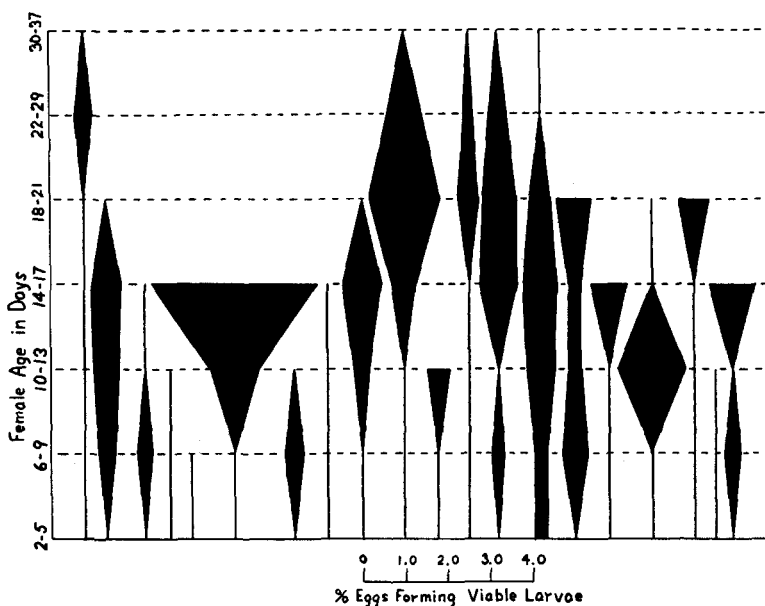

FIGURE 3.—Effect of age on rate of parthenogenesis in twenty *D. polymorpha* diploid virgins. The reproductive behavior of each female is represented by a vertical bar, with the width of the bar indicating the percentage of unfertilized eggs forming viable larvae at any given age. The height of the bar indicates the length of life for each female. It will be noted that in general the rate of parthenogenesis increases with age of female, and that also the proportion of females showing *any* parthenogenesis increases as the group ages. See also table 8 and text.

3. Effect of temperature on parthenogenesis

In an effort to find some sort of treatment which might increase the rate of parthenogenesis to a level at which the phenomenon could be studied more easily, many treatments and combinations of treatments, both of the virgin females and of the eggs which they produced were tried. Many of these preliminary experiments were poorly controlled, and if the experiments had had some slight effect on the rate of parthenogenesis, this effect could well have been overlooked. Some of the environmental factors tested were: type of

food, temperature of rearing and oviposition for the females, treatment of the eggs with ultra-violet, heat, cold and carbon dioxide. None of these, except high temperature, had any obvious effect. It was soon observed that holding the virgin females at 30°C for at least three days prior to oviposition resulted in a clear increase in rate of parthenogenetic development. The data on this point are summarized in table 9. The virgin females used in the controls and the three experiments were all reared at 25°C in the same set of culture bottles. In the column headed Expt. I are given the results of keeping females at 30°C for one week and then following the development of their eggs at the same temperature. It will be noted that the percentage of eggs starting development (including those which die in the embryonic or early

TABLE 9

Effects of temperature on rates of parthenogenesis in D. parthenogenetica. All females tested were reared at 25°C and were derived from the unselected bisexual strain. High temperature females were kept at 30°C for one week prior to collection of eggs.

	Controls: Females 25°C Eggs 25°C	Expt. I. Females 30°C Eggs 30°C	Expt. IIa* Females 30°C Eggs 25°C	Expt. IIb** Females 30°C Eggs 25°C
No. females tested	218	79		139
Total eggs	74,538	22,025	42,729	5,286
Dead embryos	620	491	774	92
Larvae	61	18	60	14
% Eggs starting development	0.91	2.31	1.95	2.01
% Eggs forming viable larvae	0.08	0.08	0.14	0.26
% Survival among eggs starting development	8.96	3.54	7.19	13.21

*Females were kept at 30°C and changed to fresh food every 24 hours, at which time the vials with eggs were moved to the 25°C incubator.

**Females were kept at 30°C and changed to fresh food every 4 hours, at which time the vials with eggs were removed to the 25°C incubator.

larval stage as well as those which form viable larvae) is 2.31% in Expt. I as compared to 0.91% in the controls. This difference is highly significant, the chi square value of 272.7 leading to a P value of less than 0.001. However, in spite of the increase in the rate of eggs starting development, the percentage of developing eggs which survive to form viable larvae is much decreased, 3.54% for the experimentals as compared to 8.96% for the controls. This difference is also highly significant, the chi square value of 13.8 leading to a P value of less than 0.001. The net result of these two differences between the controls and Expt. I was that the percentage of eggs forming viable larvae remained the same: 0.08%.

It was felt that perhaps the higher mortality in the eggs starting development in Expt. I was at least partially a direct effect of temperature on viability. In order to test this Expts. IIa and IIb were carried out.

In Expt. IIa the females were maintained at 30°C as in Expt. I, but the vials containing the eggs were removed to a 25°C incubator every twenty-four hours, thus, the eggs remained at 30°C for a length of time which varied from 0 to 24 hours, and were kept at 25°C thereafter. In Expt. IIb a similar technique was employed, except that the freshly-laid eggs remained at the higher temperature for much shorter periods ranging from 0 to 4 hours.

In Expt. IIa the percentage of eggs starting development is significantly higher than in the controls, 1.95% as compared to 0.91%, but it is also significantly lower than in Expt. I, (chi square: 9.0; P value less than 0.003). In Expt. IIb also the percentage of eggs starting development is significantly higher than in the controls, 2.01% as compared to 0.01% (chi square: 60.2; P values less than 0.001), but in this case not significantly lower than in Expt. I. Expts. IIa and IIb do not differ significantly in the percentage of eggs starting development, and when lumped and compared with Expt. I they show a significantly lower starting frequency (chi square 9.3; P = 0.002).

The same female parents were used in Expts. IIa and IIb, and as explained above the females used in the controls and all three experiments came from the same culture bottles. Thus two possible reasons might be given for the percentage of eggs starting development being lower when the eggs were removed to 25°C, as compared to being left at 30°C. Either the higher temperature *does* act on the eggs *after* oviposition, and cause a higher proportion to begin development, or else the fact that the eggs produced in Expts. IIa and IIb came from somewhat older females than those in Expt. I might have had some effect. As noted above, there is no obvious effect of age on rates of parthenogenesis for females kept at 25°C; however, this finding might not hold at 30°C.

It will be noted that with regard to the percentage survival among eggs which *had* begun development, both IIa (7.19%) and IIb (13.21%) show a higher rate of survival than I (3.54%). The P values in the tests of the differences are in both cases less than 0.01. The chi square of the difference between IIa and IIb is 4.69, with a P value of 0.03, indicating that in all probability a prompt removal of the eggs from 30°C as in IIb does raise the rate of survival among those eggs starting development. The survival rates for IIa and IIb do not differ significantly from that of the controls.

As for the percentage of eggs forming viable larvae, it will be noted from table 9 that in both IIa and IIb the net fertility of the virgins, as indicated by production of viable larvae is greater than that of the control virgins, in both cases comparisons of percentage of eggs forming viable larvae with the control figure of 0.08% give chi square values leading to P values of less than 0.01. A comparison of the percentage of viable larvae formed in IIa (0.14%) with that in IIb (0.26%) gives a chi square value of 4.73, leading to a P value of 0.03, and indicating that apparently the early removal of eggs from high temperature as in IIb does result in a significantly greater yield of viable larvae than when they are only removed every twenty-four hours as in IIa.

Thus, to summarize: Maintenance of the virgin females at high tempera-

tures during the time the unfertilized eggs are developed leads to a significantly higher rate of initiation of development followed by a significantly higher mortality rate if the eggs are left at the higher temperature. Prompt removal of the eggs to a moderate temperature has little effect on the higher rate of initiation of development, but results in a significant reduction in the mortality of developing eggs, with the result that the net effect of keeping the virgin females at high temperatures, but removing their eggs to lower temperatures is an approximately three-fold increase in rate of production of viable larvae.

4. Effect of virginity on parthenogenesis

A. *Conspecific matings with sterile XO diploid males.* The unisexual strain of *D. parthenogenetica* regularly produced about 1.5% of sterile XO diploid males. In order to test the possible effect of such males on the rate of partheno-

TABLE 10

Tests of parthenogenesis in D. parthenogenetica females mated to sterile XO males. The five females used in this test were kept with two males each throughout the experiment, and only after copulation had been actually observed were egg counts made. Both males and females belonged to generation 9 of the unisexual strain. The control is based on the rate of 69 virgin females of generation 9. (See table 6.)

Female No.	Total eggs	Dead embryos	Larvae	% Total eggs starting development	% Total eggs forming viable larvae
I	925	14	5	2.05	0.54
II	702	10	0	1.42	0.00
III	464	5	1	1.29	0.22
IV	860	7	1	0.93	0.12
V	720	29	2	4.31	0.28
Total	3,671	65	9	2.02	0.25
Control	17,740	327	66	2.22	0.37

genesis, five diploid virgins from generation nine of the unisexual strain were set with two XO males each, in vials, and checked frequently until all five females had been seen in copula. After copulation was observed each female was kept with her mates and changed to fresh food daily; the rate of parthenogenesis being determined over a period of about ten days. The results for the five females are shown in table 10. Although there is a good deal of variability between experimental females, it seems clear that copulation with sterile males has little or no effect on the rate of parthenogenesis.

B. *Conspecific matings with fertile males.* In searching for a possible adaptive value for parthenogenesis in *D. parthenogenetica* the possibility suggested itself that inseminated wild females might, after they had exhausted their sperm supply, continue to reproduce by parthenogenesis, and might then show a considerably higher rate of parthenogenesis than virgin females. Such behavior would have considerable adaptive value in a rare species since then a single insemination would be of potentially very great reproductive value.

If such behavior existed in nature, then laboratory females which had previously mated but had exhausted their sperm supply might be expected to show a higher rate than their virgin sisters. In order to test this possibility nine homozygous garnet virgin females were mated individually to two fertile wild-type males each. These females and their mates were changed to fresh food daily for a week, and until large numbers of larvae indicated that insemination had occurred. At the end of this time the males were discarded and the females maintained in separate vials with daily changes to fresh food until nineteen days after the removal of the males.

Daily counts of the eggs laid each day were recorded, as well as the total numbers of garnet and wild-type males and females produced by each batch of eggs. As indicated above mature larvae reared in vials tend to pupate in the cotton plug, and the pupae so formed to dry out. In order to eliminate this difficulty, in this experiment, after the eggs were counted the vial containing them was unplugged and placed in a half-pint culture bottle which had a double sheet of Kleenex in the bottom which was dampened with water, but was not soaking wet. The culture bottles were capped with cardboard caps. This rather laborious technique almost completely eliminated larval suicide since the mature larvae either pupated at the lip of the unplugged vials or dropped down and pupated in the damp Kleenex on the bottom of the culture bottle. Of the progeny produced from any batch of eggs those which were wild-type females were clearly biparental. The garnet males could have been either biparental or *impaternate*, but since only 1.5% of the *impaternate* progeny of diploid virgins are males (see table 1), very little error was introduced by classifying all males as biparental. The garnet females were clearly *impaternate* (see below). Thus for any one day, subtraction of the number of biparental individuals from the total number of eggs produced left as a remainder the number of unfertilized eggs. Since a small percentage of the fertilized eggs might not have produced adults, this estimate of the number of unfertilized eggs should be if anything too high, and hence the derived rate of parthenogenesis from such unfertilized eggs would be too low.

Actually the error introduced in this way is probably very small since examination of 1,326 eggs from the nine females prior to the elimination of the males showed that of the 982 which actually hatched, 947, or 96.4% produced viable adults. Of the remaining 344 which failed to hatch, only four were detected with dead embryos in them, and this small number of dead embryos could well have been produced parthenogenetically.

In table 11 the results from the nine females are summarized. In this table the individual counts are grouped according to the percentage of unfertilized eggs on a particular day. Thus in the first line in the body of the table are listed the 2,736 unfertilized eggs produced by the nine females on days when no biparental progeny (i.e., 100% unfertilized eggs) were produced; in the second line are listed the 1,506 unfertilized eggs produced on days when from 70% to 99% of the eggs were unfertilized, etc. It will be noted that only 0.10% of the unfertilized eggs produced adults, a figure which is approxi-

TABLE 11

Rates of parthenogenesis in non-virgin females of *D. parthenogenetica*. Nine females were mated individually to two males each and kept for a week with their mates and until large numbers of larvae were produced, indicating insemination. Then the males were discarded and the numbers of eggs and numbers and kinds of progeny recorded for each female for each day thereafter. The data from the nine females are grouped into categories on the basis of the percentage of eggs unfertilized on any given day. See text.

Percentage of total eggs unfertilized	Number of unfertilized eggs	Number of impatent adults	Percentage of unfertilized eggs forming adults
100	2,736	4	0.15
70-99	1,506	0	0.00
50-69	537	1	0.19
1-49	326	0	0.00
Total	5,105	5	0.10
Control virgin garnet females	9,281	11	0.12

mately the same as that in the controls. Thus it may be concluded that in so far as conspecific inseminations are concerned, virgin and non-virgin females have approximately the same rates of parthenogenesis.

C. *Exposure to males of other species.* Although mating with conspecific males apparently does not affect the rate of parthenogenesis the possibility still exists that matings with males of other species might have some effect. In *Mollienisia formosa*, HUBBS and HUBBS (1946) have shown that no males of this species are found in nature and that virgin females are apparently sterile. Females will mate with males of congeneric as well as extra-generic species, and either type of mating results in the production of females which are typi-

TABLE 12

Rates of parthenogenesis in *D. parthenogenetica* homozygous garnet females exposed to males of various species during the egg-laying period. Day-old females were placed with equal numbers of males of the various species and kept with them on fresh food for 10 days prior to testing and throughout the testing period.

	Species of males				
	Control, virgins	<i>D. polymorpha</i>	<i>D. cardini</i>	<i>D. simulans</i>	<i>D. melanogaster</i>
No. females tested	57	43	46	62	73
Females inseminated	—	19/38	11/34	—	—
Total eggs	23,371	10,215	13,893	15,808	10,428
Dead embryos	109	18	26	37	18
Larvae	5	4	2	1	1
% Eggs starting development	0.49	0.22	0.20	0.24	0.18
% Eggs forming larvae	0.01	0.04	0.01	0.01	0.01
% Survival among eggs starting development	4.39	18.19	7.14	2.63	5.26

cal *M. formosa*. Thus the females apparently act as reproductive parasites on the males of other species.

It was not practical to make large-scale tests of males of all species believed to be sympatric with *D. parthenogenetica*. However four species were tested: *D. polymorpha*, *D. cardini*, *D. simulans* and *D. melanogaster*. Of these four the first two belong to the same species group as *D. parthenogenetica*, the latter two do not. *D. parthenogenetica* has been taken in Atlixco, Mexico, as have *D. cardini*, *D. simulans* and *D. melanogaster*. *D. polymorpha* is not known from Mexico, and the most northern locality from which it is recorded is apparently Guatemala (STALKER 1953).

The results of the tests with alien males are recorded in table 12. In these tests homozygous garnet females of *D. parthenogenetica* were kept in vials with equal numbers of alien males for ten days prior to testing. At the time of original exposure to the males the females were one day old while the males varied from one to four days of age. During the test period of approximately one week the flies were kept in vials changed daily, with three pairs of flies per vial. It is at once clear from table 11 that as compared to the garnet control virgin females, the mated females showed no increase in rate of parthenogenesis. In the case of the males of *D. polymorpha* and *D. cardini* matings were frequently observed prior to the test period, and dissection of the *D. parthenogenetica* females confirmed that copulations had been completed, since in the tests with *D. polymorpha* 19/38, and in the tests with *D. cardini* 11/34 of the females were inseminated. Although the males of both *D. simulans* and *D. melanogaster* courted *D. parthenogenetica*, no attempted copulation was observed, and the females were not examined for presence of sperm.

To summarize: For the four species tested it seems clear that unlike the situation in *Mollinisia*, exposure of virgin females of *D. parthenogenetica* to males of other species has no important effect on the rate of parthenogenesis.

THE RATE OF PRIMARY NON-DISJUNCTION IN *D. PARTHENOGENETICA*

In the course of early attempts to obtain XXY diploid females by primary non-disjunction of the X-chromosomes in XX diploid females, crosses between homozygous garnet diploid females and wild-type males produced 12,115 diploid progeny. Of these 6,839 were wild-type females, 5,263 were garnet males and 13 were garnet females. There were no wild-type males. The exceptional individuals produced by primary non-disjunction should have been garnet females and wild-type males. This complete absence of exceptional males, although XO males are viable (see table 1), suggested that the 13 garnet females produced were impaternal rather than primary non-disjunctive exceptions. Each of the 13 garnet females was mated to wild-type males, and none of them produced any exceptional progeny, lending force to the assumption that they were impaternal. If primary non-disjunction occurs in this species, it is obviously very infrequent. In *D. melanogaster* it is well known that only non-crossover X-chromosomes show non-disjunction, and the low rate in *D. parthenogenetica* may well be correlated with what appears

in somatic metaphases to be an unusually long X-chromosome. In larval neuroblasts the length of the X-chromosome is about half of the combined lengths of the two major autosomes.

CONCLUSIONS

The mechanism of parthenogenesis

Considering only *D. parthenogenetica*, for which the most complete data are available, it is clear that two related phenomena are involved in effective parthenogenesis.

First, in the unfertilized egg there must be an initiation of cleavage divisions. Secondly, the haploid chromosome complement of the mature egg must be replaced by a diploid or triploid complement. In the case of eggs from diploid females, this last step involves fusion of the haploid meiotic products.

The assumption that cleavage may occur independently of nuclear fusion is based on two facts. 1. The production of 41% diploid males by virgin triploid females can apparently be explained only by the development of unfused XO 2A mature eggs. 2. The very high mortality (80% or higher) of impaternal embryos from diploid females is very difficult to explain except as the result of the production of haploid embryos, since the same females, when crossed to normal fertile XY males of a closely related strain produce almost no dead embryos, thus indicating that the high embryonic lethality can hardly be the result of a lethal gene or genes carried in the stock, and is rather the result of cleavage of eggs without fusion.

While cleavage may occur without nuclear fusion, the data are not critical for answering the following two questions: 1. Is fusion always followed by subsequent cleavage, that is, is some physiological or cytological peculiarity of the egg necessary for both fusion and cleavage, this condition sometimes promoting cleavage only, at other times promoting both fusion and cleavage? 2. Does fusion in itself promote cleavage? Any attempt to answer these two questions with the data at hand entails arguments so lengthy and involved that it does not seem worthwhile to present them here, as they lead to no unequivocal conclusions.

The evolutionary significance of parthenogenesis in Drosophila

In the animal kingdom as a whole, as SUOMALAINEN (1950) has pointed out, the occurrence of thelytoky, or the development of females from unfertilized eggs, is widespread and sporadic, occurring in single species or races rather than being characteristic of larger groups (cyclical thelytoky is an exception to this generalization). This suggests that many of the known cases of thelytoky are of recent origin, and that its actual successful development from bisexual forms must have occurred many times. It is generally supposed (SUOMALAINEN 1950; VANDEL 1936; WHITING 1945) that thelytoky must have arisen from bisexual forms showing occasional or accidental production of females from unfertilized eggs (tychothelytoky). There is some basis for this supposition as indicated by the findings of several workers that ty-

chothelytokous forms occur in bisexual strains, and that in some cases, as in *Solenobia triquetrella*, the few females that do develop from the unfertilized eggs of bisexual strains may themselves produce eggs nearly all of which develop without fertilization. In *Drosophila*, the marked increase in the rate of parthenogenesis in *D. parthenogenetica* and *D. polymorpha* under severe selection is a less striking example of the same phenomenon. SEILER (1942) believes that in its inception from tychothelytokus forms, thelytoky involves substitution of automixis for fertilization. He further believes that automixis may then gradually be replaced by apomixis involving only one equational maturation division. However, as both SEILER and SUOMALAINEN point out such an intermediate step is not always necessary, since in *Rhabditis pellio* at least, HERTWIG (1920) has observed the sudden origin of an apomictic parthenogenetic race through mutation or segregation in a laboratory stock.

If a tychothelytokous form is to develop into a thelytokous one, a series of rather rare events must occur. First, the impaternal progeny of the tychothelytokous female or females must themselves be sufficiently fertile as virgins to avoid extinction of the unisexual strain. Secondly, the thelytoky, if imperfect at first, as in *Drosophila*, must be rapidly improved, presumably by selection. Such improvement would involve not only a higher rate of development of unfertilized eggs, but also a higher frequency of nuclear fusion in order to restore the diploid chromosome complement. That selection may result in a higher rate of development of unfertilized eggs is shown by the data for both *D. parthenogenetica* and *D. polymorpha*. In these species the frequency of unfertilized eggs *starting* development in the unselected bisexual strains was 0.9% and 0.3%, respectively, while in the selected unisexual strains the percentages were raised to 8% and 6%, respectively. That selection may result in a higher percentage of nuclear fusions in those eggs *starting* development is indicated by the increased rate of survival. In *D. parthenogenetica* selection increased the survival among impaternal embryos from 9% to 19%, in *D. polymorpha* the survival was increased from less than 2% to 18%.

Even increased initiation of development, and an increased tendency for the fusion of haploid meiotic products is not enough if a large proportion of the fusions involve three rather than two nuclei, and consequent production of the almost completely sterile triploid virgins. Thus if thelytoky were to become functional in a wild strain, the pattern of fusion would have to become modified to largely eliminate triploid production.

Populations of the strain developing functional thelytoky would have to exist in populations which were isolated ecologically or by distance from the bisexual forms, or else selection for thelytoky would be largely neutralized by crosses with fertile bisexual males. Ultimately, of course, reproductive isolation of a rather complete sort might arise in which thelytokous females might refuse to mate with fertile males, or might become structurally or physiologically unable to use the sperm they received in such matings.

In the case of *D. parthenogenetica* practically nothing is known of the ecology or population structure, except that it is rare in collections. Judging

from the feeding habits of other members of the species group it may be supposed that it, too, is a fungus feeder, and the collection data suggest that it is either rare, or very local in its distribution. Locally distributed small populations, would, if they actually exist, furnish the temporary isolation required if a functional thelytokous strain were to develop in nature. Although the very low rate of parthenogenesis observed in the one wild strain first studied makes the development of a wild thelytokous strain seem highly improbable, it must be remembered that the single wild strain representing the species in the laboratory may not indicate the average rate of parthenogenesis in nature, which might be rather high in some individuals. Also, the evidence that thelytoky has developed in other bisexual forms not once, but many times, indicates that the improbable is not the impossible. Thus we feel, that in the case of *D. parthenogenetica*, and probably many other species of *Drosophila*, the very low rates of parthenogenesis observed are of some potential value to the species in supplying the first step toward thelytoky. Its eventual development depends on the right combination of ecological and genetical factors at the right time.

Polyploidy and parthenogenesis

The repeated discovery of polyploidy in animals among those forms which show thelytoky and the rarity of its discovery in bisexual forms has in a sense verified the prediction made by MULLER (1925) that the XY chromosome mechanism in many bisexual forms would tend to prevent the establishment of polyploid strains. Although exceptions to this general prediction are known, see for example GOLDSCHMIDT (1953) and DARLINGTON (1953), still it seems clear that MULLER's predictions hold to a large extent. In thelytokous species on the other hand, no problem of XY autosome unbalance exists, and one would expect to find polyploids among such forms. For this reason any species which, like *D. parthenogenetica*, may survive by parthenogenesis, is of particular interest in regard to possible development of polyploidy, especially so in this case since the production of one type of polyploids (triploid females), is a regular feature of the parthenogenetic mechanism.

Although in apomictic thelytokous forms, or in automicts in which there is no production of nuclei with a reduced chromosome number and consequently no subsequent nuclear fusion, the establishment of triploids, tetraploids and higher ploid series should occur readily enough; and has occurred; in the case of automicts in which there is a sufficiently normal meiosis to allow for the production of reduced nuclei, with the need for subsequent nuclear fusion, any irregular development of eggs *without* nuclear fusion (as in the formation of haploids from diploid mothers and diploid males from triploid mothers), would in itself constitute a very effective bar to the establishment of a polyploid strain, either in the laboratory or in nature, even if the polyploids, say tetraploids, were themselves viable and fertile. The reason for this is that if, as is the case in the most fertile unisexual laboratory strain of *D. parthenogenetica*, 80% of the developing eggs show no nuclear fusion, then

a tetraploid virgin would produce about four times as many diploid as tetraploid daughters, and unless the tetraploids were greatly superior in vigor or fertility to the diploids, the tetraploidy should disappear as fast as it was produced. As for triploid females, which are known to be produced regularly by diploid virgins, they clearly show a great reduction in fertility, as would be expected in a form producing reduced nuclei in meiosis. Thus in the case of *D. parthenogenetica*, as long as parthenogenesis exists only in its present very imperfect state, with frequent cleavage of eggs without nuclear fusion, then neither in the laboratory nor in nature could a stable polyploid strain be developed.

ACKNOWLEDGMENT

It is a pleasure to acknowledge the capable and painstaking technical assistance of Miss Lois Schuermann and Miss Eleanor Suchland during the course of this investigation.

SUMMARY

1. Parthenogenesis is described in the family Drosophilidae. In a survey of twenty-eight members of the family a low rate of parthenogenesis was discovered in twenty-three species. Of these, only three: *D. parthenogenetica*, *D. polymorpha* and *D. affinis* produced adult progeny; in the remaining twenty species impaternal individuals died in embryonic or larval stages.

2. In *D. parthenogenetica* diploid virgins produce diploid and polyploid daughters as well as rare XO sterile diploid males. The polyploid daughters have been shown to be triploid by a study of their metaphase chromosomes, wing cell size, and breeding behavior. Triploid virgins in this species produce diploid and triploid females and large numbers (40%) of sterile XO diploid males.

3. Diploid virgins of *D. parthenogenetica* heterozygous for the sex-linked recessive garnet (*g*) produce homozygous and heterozygous diploid females as well as $+/+g$ and $+/g/g$ triploid females. Apparently no $+/+/+$ nor $g/g/g$, triploid females are produced in this way. No garnet mosaics have been found.

4. Diploid females crossed to fertile diploid males produce few if any polyploid progeny or primary X-chromosome exceptional individuals.

5. Of the unfertilized eggs from diploid females which start development, 80% die in the late embryonic or early larval stages.

6. It is concluded that the mechanism of parthenogenesis in diploid females involves two normal meiotic divisions followed by fusion of two of the derived haploid nuclei to form diploid progeny, or fusion of three such nuclei to form triploid progeny. In triploid females it is concluded that similar fusions may produce diploid or triploid females but that the large number of diploid XO sterile males are the result of cleavage *without* prior nuclear fusion. Such cleavage without fusion in the eggs of diploid females would lead to the production of haploid embryos and is presumably responsible for the considerable embryonic and early larval death in such eggs.

7. Evidence derived from the progeny of XXY diploid virgins indicates that

binucleate fusion in unfertilized eggs may involve two *terminal* haploid nuclei (those derived from the same secondary oocyte) or two *central* nuclei (those derived from different secondary oocytes).

8. Although certain types of nuclear fusion in the eggs of triploid virgins should result in the production of tetraploid progeny, no wholly tetraploid individuals have been found, suggesting that they are relatively inviable in *D. parthenogenetica*.

9. The establishment of unisexual strains in *D. parthenogenetica* and subsequent rigorous selection for parthenogenesis over a period of seventeen generations has raised the production of viable progeny from the original rate of 8/10,000 to 151/10,000 unfertilized eggs. Similar selection in *D. polymorpha* has increased the rate from 1/19,000 to 133/19,000.

10. When diploid virgins of *D. parthenogenetica* are kept at 30°C for ten days prior to egg production and the freshly laid eggs returned to 25°C, the rate of production of viable progeny is increased approximately three-fold.

11. In *D. polymorpha* diploid virgin females the rate of parthenogenesis (as measured by the production of viable progeny) increases approximately twenty-fold as the females age. No such age-effect is found in *D. parthenogenetica*.

12. Females of *D. parthenogenetica* mated to sterile XO or fertile XY conspecific males, or mated to fertile males of related species show essentially the same rates of parthenogenesis as do virgin females.

13. It is considered that parthenogenesis as it now exists in *Drosophila* may be of potential value in the eventual production of effectively parthenogenetic strains, although the probability of such an event seems rather remote.

LITERATURE CITED

- BRIDGES, C. B., and E. G. ANDERSON, 1925 Crossing over in the X chromosomes of triploid females of *Drosophila melanogaster*. *Genetics* **10**: 418-441.
- CARSON, HAMPTON L., 1946 The selective elimination of inversion dicentric chromatids during meiosis in the eggs of *Sciara impatiens*. *Genetics* **31**: 95-113.
- DARLINGTON, C. D., 1953 Polyploidy in animals. *Nature* **171**: 191-194.
- DOBZHANSKY, TH., 1929 The influence of the quantity and quality of chromosomal material on the size of the cells of *Drosophila melanogaster*. *Roux Arch.* **115**: 363-379.
- FAHMY, O. G., 1952 The cytology and genetics of *Drosophila subobscura*. VI. Maturation, fertilization and cleavage in normal eggs and in the presence of the cFOSS-over suppressor gene. *J. Genet.* **50**: 486-506.
- FRICK, KENNETH E., 1951 Parthenogenetic reproduction in *Phytomyza plantaginis*. *Science* **114**: 576.
- GOLDSCHMIDT, E., 1953 Multiple sex-chromosome mechanisms and polyploidy in animals. *J. Genet.* **51**: 434-440.
- HERING, MARTIN, 1926 Nachgewiesene parthenogenetische Fortpflanzung bei einer blattminierenden acalyptraten Muscidae (Dipt.). *Zool. Anzeig.* **68**: 283-287.
- HERTWIG, P., 1920 Abweichende Form der Parthenogenese bei einer Mutation von *Rhabditis pellio*. Eine experimentelle cytologische Untersuchung. *Arch. f. mikr. Anat.* **94**: 303-337.
- HUBBS, C. L., and L. C. HUBBS, 1946 Experimental breeding of the Amazon Molly. *The Aquarium Journal*.

- HUETTNER, A. F., 1924 Maturation and fertilization in *Drosophila melanogaster*. J. Morph. **39**: 249-265.
- MULLER, H. J., 1925 Why polyploidy is rarer in animals than in plants. Amer. Nat. **59**: 346-353.
- PATTERSON, J. T., and G. B. MAINLAND, 1944 The Drosophilidae of Mexico. Univ. of Texas Publ. No. 4445: 9-102.
- SEILER, J., 1942 Resultate aus der Kreuzung parthenogenetisches und Zweigeschlechtlicher Schmetterlinge. Arch. Klaus-Stift. Vererb-Forsch. **17**: 513-528.
- STALKER, HARRISON D., 1951 Diploid parthenogenesis in the cardini species group of *Drosophila*. Genetics **36**: 577 (Abstract).
- 1952 Diploid and triploid parthenogenesis in the *Drosophila cardini* species group. Genetics **37**: 628-629.
- 1953 Taxonomy and hybridization in the cardini group of *Drosophila*. Ann. Ent. Soc. Am. (in press).
- STURTEVANT, A. H., 1923 The probable occurrence of parthenogenesis in *Ocithipila polystigma* (Diptera). Psyche **30**: 22-27.
- SUOMALAINEN, ESKO, 1950 Parthenogenesis in animals. Adv. in Genetics **3**: 193-253.
- VANDEL, A., 1936 L'evolution de la parthénogenèse naturelle. C. R. XII Cong. Intern. Zool. Lisbonne.
- WHITE, M. J. D., 1945 Animal Cytology and Evolution. The University Press. Cambridge, pp. 1-375.
- 1946 The evidence against polyploidy in sexually-reproducing animals. Amer. Nat. **80**: 610-618.
- WHITING, P. W., 1945 The evolution of male haploidy. Quart. Rev. Biol. **20**: 231-260.
- WINKLER, HANS, 1920 Verbreitung und Ursache der Parthenogenesis in Pflanzen und Tierreiche. Jena. Verlag von Gustav Fischer.