

TWO DIFFERENT h^- MATING TYPES IN *SCHIZOSACCHAROMYCES POMBE*¹

HERBERT GUTZ AND FRANK J. DOE²

Institute for Molecular Biology, The University of Texas at Dallas, Dallas, Texas 75230

Manuscript received July 15, 1972
Revised copy received April 16, 1973
Transmitted by GERALD R. FINK

ABSTRACT

In the strains of *Schizosaccharomyces pombe* introduced by LEUPOLD (1950, 1958) into genetic research, heterothallic and homothallic mating types are known. The mating types are determined by two closely linked genes. We show that two distinct heterothallic $-$ mating types exist: a stable one (h^-S) and an unstable one (h^-U), which can mutate to heterothallism $+$ and homothallism. A proposal for incorporation of the new mating type h^-U into LEUPOLD's two-gene scheme is discussed.

THE fission yeast *Schizosaccharomyces pombe* Lindner is a haplontic organism whose life cycle and mating-type system has been described by LEUPOLD (1950, 1958, 1970). In the strains introduced by this author into genetic research, three phenotypically different mating types are known: homothallism (h^{90}),³ heterothallism $+$ (h^+), and heterothallism $-$ (h^-). LEUPOLD (1950) found that between these three "alleles", spontaneous mutations take place in all possible directions. With respect to the h^- mating type, he made the puzzling observation that his original h^- strain did not mutate to any other mating type, whereas h^- mutants which had originated in h^+ strains were unstable, mutating to h^{90} and back to h^+ . LEUPOLD (1950) supposed that newly originated h^- mutants show a greater mutability than old h^- strains.

At a later date LEUPOLD (1958) observed crossing over in the mating-type region. He was able to distinguish two sites 1.1 map units apart which appear to be independent genes. Furthermore he demonstrated the existence of two different heterothallic $+$ mating types, which were called h^{+N} and h^{+B} (h^{+N} is the $+$ mating type described by LEUPOLD in 1950). LEUPOLD (1958) gave a formal scheme in which he assumed that the mating reaction is under the control of two genes (see DISCUSSION and Table 2). In his 1958 paper, LEUPOLD specified the following main types of spontaneous mutations: h^{+N} to h^{90} , h^{90} to h^{+N} , and h^{+B} to h^- . With respect to h^- strains, he said that these appear to be quite stable.

¹ Supported by NSF Grant GB-15148, NIH Grant GM-13234 (Program in Molecular Biology), and by The University of Texas at Dallas Research Fund.

² Permanent address: Biology Department, University of Dallas, Irving, Texas 75060.

³ LEUPOLD (1950) described originally two homothallic "alleles" (h^{90} and h^{40}). The difference between h^{90} and h^{40} cultures was that the former formed 90% ascospores whereas the latter formed only 40% spores; however, the strain carrying the h^{40} "allele" has since been lost (LEUPOLD, personal communication).

Thus, as to the mutability of h^- strains, some contradiction seems to exist between LEUPOLD's observations of 1950 and 1958. We have evidence that in *S. pombe* two clearly distinguishable h^- mating types exist, one being stable and the other being unstable.

MATERIALS AND METHODS

We used LEUPOLD's original wild-type strains L972 (mating type h^-) and L975 (mating type h^{+N}). Six derivatives of L975, each bearing an auxotrophic mutation, were used as additional h^{+N} strains. Four h^{+R} recombinants were isolated from crosses of the type $h^{+N} \times h^-$ with the help of tetrad analyses (see LEUPOLD 1958).

We tested these strains for the occurrence of spontaneous mating-type mutants by streaking them on plates with malt-extract agar (MEA; 3% Bacto-malt extract, 2% agar). We made the streaks in such a manner that the resulting colonies were crowded (i.e., many of the colonies were contiguous); this procedure allowed the detection of mutants from one heterothallic activity to the opposite (see below). The MEA plates were incubated for one day at 30°C and for four to six additional days at 25°C. We then treated the plates with iodine vapors (LEUPOLD 1955) and checked the colonies for the presence of ascospores with the aid of a stereomicroscope. The spores of *S. pombe* contain in their walls an amylose-like substance which turns black with iodine (positive iodine reaction); this substance is absent in vegetative cells.

The iodine treatment is a suitable method for detecting mating-type mutations. Mutants from heterothallism to homothallism are recognizable as sectors or colonies giving a homogeneously positive iodine reaction. Mutations from heterothallism+ to heterothallism— or vice versa, form nonsporulating sectors or spots which are separated from the main cell mass by fine lines with positive iodine reactions. If heterothallic colonies of opposite mating types are contiguous, distinct iodine-positive lines are visible between them. Such pairs of colonies represent a convenient method for the detection and isolation of mutants from one heterothallic mating-type activity to the opposite. With the experimental procedure used, no quantitative determinations of the frequencies can be made with which the different mating-type mutants occur. Since no simple method seems to exist for this purpose, we will use phrases such as "relatively many" or "relatively few" to indicate obvious differences in the numbers of iodine-positive sectors or lines. In RESULTS, section IV, these relative differences will be described in more detail.

The mating-type mutants were isolated by restreaking sporulating material on MEA. The mating types of heterothallic strains were determined as described by LEUPOLD (1970). Other experimental techniques have been described in the latter paper and by GUTZ (1971).

RESULTS

I. *Wild-type strain L972 (mating type h^-):* In the streaks made from this strain, we could not detect sporulating mutants of any type. Furthermore, L972 has been used constantly for twelve years in the laboratory of the senior author (H.G.). In all these years no mutations to homothallism or heterothallism + were observed. Thus, the h^- mating type present in L972 appears to be completely stable.

II. *Strains of mating type h^{+R} :* All four strains gave identical results. In accordance with the observations of LEUPOLD (1958), we found relatively many iodine-positive lines within colonies or between contiguous colonies. Such pairs consist of a h^{+R} and a h^- colony. Fourteen h^- mutants of independent origin were isolated. Upon subsequent testing, all mutants proved to be stable h^- strains and thus behaved identically to L972. We observed no homothallic mutants in the h^{+R} cultures.

III. *Strains of mating type h^{+N}* : The wild-type strain L975 and its six auxotrophic derivatives exhibited the same behavior with respect to mating-type mutations. As described by LEUPOLD (1958), homothallic mutants (h^{90}) occurred in all streaks of the h^{+N} strains. However, we also observed a few iodine-positive lines which were indicative of mutations to heterothallism —. From the cell material surrounding such iodine-positive lines, we were able to isolate mutants to heterothallism —. The properties of these mutants are described in the next section.

IV. *The new mating type h^{-U}* : We examined 19 h^{-} mutants which had been isolated from h^{+N} strains; the mutants were of independent origin. All nineteen strains proved to be unstable. They had the following properties: when streaked on MEA, the resulting colonies showed relatively many iodine-positive lines. From the cell material adjacent to such lines, mutants to heterothallism + could always be isolated. In addition to these + mutants, we also obtained a few homothallic mutants from the h^{-} strains under discussion. Therefore, the mutants to heterothallism — which were detected in h^{+N} cultures differ from L972 and the h^{-} mutants found in h^{+R} strains. This new — mating type will be called h^{-U} (*U* for unstable). For purposes of clarity, we suggest the designation h^{-S} for the stable — mating type (*S* for stable).

The heterothallic + mutants found in h^{-U} strains may represent a new + mating type (see DISCUSSION) for which we will use the noncommittal symbol h^{+X} . Strains being h^{+X} revert to h^{-U} and, in addition, mutate to homothallism. Thus, their mutation pattern is different from h^{+R} but similar to h^{+N} strains, for h^{+R} strains do not mutate to homothallism.

There were no detectable differences between h^{-U} mutants isolated from h^{+N} strains and those isolated from h^{+X} strains. Our h^{-U} cultures retained their unstable phenotype throughout successive subcultures; they mutated frequently to h^{+X} and to homothallism.

The different mating-type mutations which occur in heterothallic *S. pombe* strains are listed in Table 1. As was already stated in MATERIALS AND METHODS,

TABLE 1

Spontaneous mating-type mutations in heterothallic strains of S. pombe

Mating type	Relative frequency of sporulating material*	Types of mutations found
h^{+N}	+	homothallism heterothallism —
h^{+X}	+	homothallism heterothallism —
h^{+R}	++	heterothallism —†
h^{-U}	++	homothallism heterothallism +
h^{-S}	—	none

* See text for explanation.

† Stable.

the experimental procedures employed did not make it possible to determine the mutation rates. However, a clear difference was observable between h^{+R} and h^{-U} cultures in contrast to h^{+N} and h^{+X} cultures. Streaks of the former strains show much more iodine-positive material (i.e., sporulating lines and/or sectors) than streaks of the latter strains. If observed with a stereomicroscope at $30\times$ magnification, in all colonies of h^{+R} and h^{-U} strains some minute iodine-positive dots can be found. This is not true of h^{+N} and h^{+X} colonies; only in some of these can sporulating material be detected. Since h^{-U} mutates more frequently to h^{+X} than to homothallism, the above observations indicate that the mutation $h^{-U} \rightarrow h^{+X}$ takes place more often than the reverse mutation $h^{+X} \rightarrow h^{-U}$. The differences in the relative frequencies of sporulating material are indicated by the symbols $++$ and $+$, respectively, in Table 1.

V. *Mapping of h^{-U}* : The mating types of *S. pombe* are determined by two genes 1.1 map units apart (see DISCUSSION). The mating-type region is flanked proximally by *his7* (5.2 map units) and distally by *his2* (1.1 map units) (LEUPOLD 1958).

From a cross $+ h^{+R} his2 \times his7 h^{-U} +$, 60 tetrads were analyzed. In all tetrads the mating-type segregation was $2 h^{+R} : 2 h^{-U}$. With respect to the histidine markers, 54 tetrads were parental ditypes, whereas six segregated $1 + h^{+R} his2 : 1 his7 h^{+R} his2 : 1 + h^{-U} + : 1 his7 h^{-U} +$. This result indicates that the new mating type h^{-U} maps in a position which is close to (or identical with) the location of the mating type in LEUPOLD's chromosome map. The absence of mating-type recombinants as well as of recombinants between *his2* and either h^{+R} or h^{-U} is insignificant since, in the above experiment, only 60 tetrads were analyzed.

DISCUSSION

Our observations show that two different heterothallic — mating types exist in *S. pombe* which can be distinguished easily by their behavior with respect to spontaneous mutations. The apparent contradiction in LEUPOLD's previous reports is now resolved. In 1950, this author had obviously observed the unstable mating type h^{-U} which occurs rarely in h^{+N} cultures, whereas in 1958 he dealt with the stable mating type h^{-S} . The latter mating type is present in the wild-type strain L972 as well as in the — mutants which originate in h^{+R} strains.

LEUPOLD (1958) has postulated that the mating-type reaction in *S. pombe* is under the control of two closely linked genes. He inferred this from the occurrence of h^{90} and h^{+R} recombinants in $h^{+N} \times h^{-S}$ crosses, and from the reverse event (h^{+N} and h^{-S} recombinants in $h^{+R} \times h^{90}$ crosses). The two genes were called *h1* and *h2*. Since these gene symbols may easily be confused with the mating-type symbols, we suggest that these be replaced by *mat1* and *mat2*; the new gene symbols also conform with the symbol suggested for the mating-type gene in *Saccharomyces* (VON BORSTEL 1969). The genotypes of h^{90} , h^{+N} , h^{+R} , and h^{-S} are shown in Table 2.

In LEUPOLD's (1958) scheme it is assumed that the genes *mat1* and *mat2* have a similar function. For *mat1* alleles of opposite heterothallic activities ($+$ or $-$)

TABLE 2

Genotypes of the mating types h^{90} , h^{+N} , h^{+R} , and h^{-S} as proposed by LEUPOLD (1958)

Mating-type reaction	Mating-type symbol	Genotype*
homothallic	h^{90}	<i>mat1</i> ⁻ <i>mat2</i> ⁺
heterothallic +	h^{+N}	<i>mat1</i> ⁺ <i>mat2</i> ⁺
	h^{+R}	<i>mat1</i> ⁺ <i>mat2</i> ⁰
heterothallic —	h^{-S} †	<i>mat1</i> ⁻ <i>mat2</i> ⁰

* The genes *mat1* and *mat2* are 1.1 map units apart and cooperate in the determination of the mating-type reaction. The superscripts, + and —, indicate alleles of opposite heterothallic function, whereas 0 indicates a nonfunctional or deleted gene. Originally, LEUPOLD used the gene symbols *h1* and *h2*; we suggest that these be replaced by *mat1* and *mat2* (see text).

† h^{-} in LEUPOLD (1958).

and for *mat2* an active + and an inactive allele are postulated. A homothallic strain results in the case of *mat1*⁻ *mat2*⁺, i.e., if one — and one + gene are present. It should be pointed out that at the present time it is not known if h^{-S} and h^{+R} strains have an inactive *mat2* allele or if *mat2* is deleted. The symbol *mat2*⁰ stands for either of these possibilities.⁴

In our experiments, the different heterothallic mating types were distinguished by their patterns of spontaneous mutation (we did not study mutations in homothallic strains; for mutations in h^{90} strains see BRESCH, MÜLLER and EGEL 1968). It has yet to be determined by recombination experiments whether h^{-U} can be incorporated into LEUPOLD's (1958) two-gene scheme. However, we would like to present the following considerations as to a possible inclusion of h^{-U} into this scheme:

1) The mating type h^{+N} has + alleles in both mating-type genes. A mutation from h^{+N} to heterothallic — would require mutations in *mat1* and *mat2*. Therefore, a one-step mutation from h^{+N} to h^{-U} appears unlikely. We prefer to postulate a two-step mutation in which a new + mating type (h^{+X}), having only one active + gene, is involved. Thus, the mutational steps leading from h^{+N} to h^{-U} would be $h^{+N} \rightarrow h^{+X} \rightarrow h^{-U}$. In other words, we assume that h^{+N} strains normally contain spontaneous h^{+X} mutants which subsequently can mutate to h^{-U} . Of course, only the h^{-U} but not the h^{+X} mutants are detectable in the h^{+N} strains by the iodine reaction.

2) The mating types h^{-U} and h^{-S} are different from each other with respect to their spontaneous mutability. Also, the hypothetical mating type h^{+X} is unlike h^{+R} (the latter gives rise only to h^{-S} mutants). Therefore, it seems reasonable to assume different genotypes for h^{-U} and h^{-S} as well as for h^{+X} and h^{+R} .

⁴ We would like to point out that LEUPOLD's postulates of the existence of alleles of complementary heterothallic activities in *mat1* as well as of an active *mat2*⁺ and an inactive (or deleted) *mat2* gene, are based on the following data (see Table 4 in LEUPOLD 1958): (1) Diploid h^{+N}/h^{-S} strains are able to sporulate whereas the homozygous strains, h^{+N}/h^{+N} and h^{-S}/h^{-S} , cannot sporulate. Thus, the heterothallic mating types contribute active though complementary functions to the life cycle of *S. pombe*. (2) Haploid h^{-S} strains cannot have a *mat2*⁺ gene since in this case they would be homothallic. A genotype *mat1*⁻ *mat2*⁻ can also be excluded because in the latter case both recombinants which, in crosses $h^{+N} \times h^{-S}$, arise from crossing over between *mat1* and *mat2* should be homothallic. However, one h^{90} and one h^{+R} recombinant originate. Thus, h^{-S} (and also h^{+R}) strains do not possess a *mat2* gene which contributes any activity to the mating-type reaction.

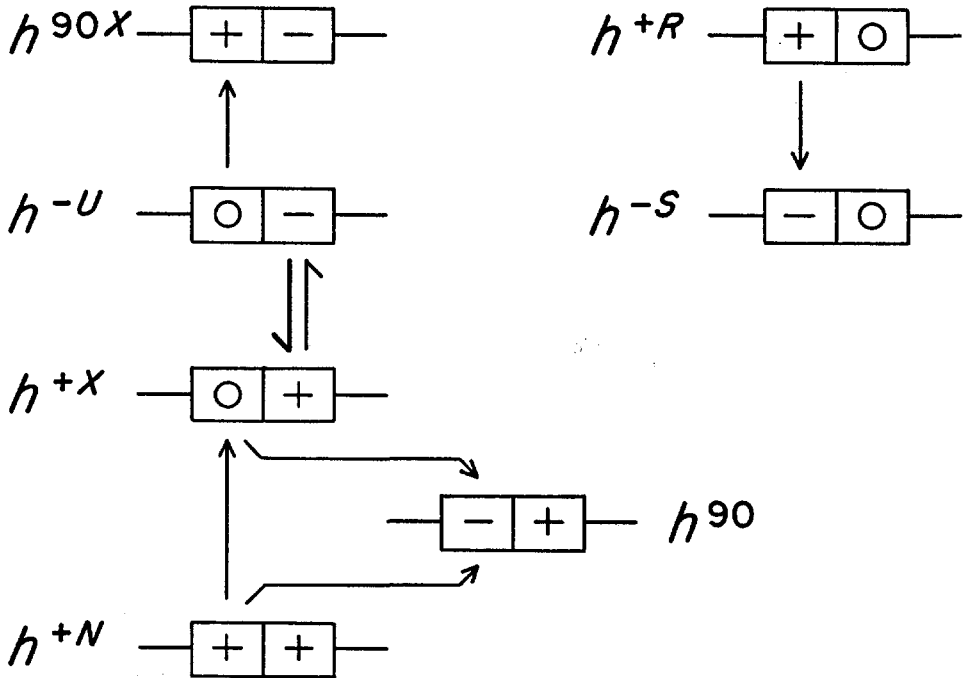

FIGURE 1.—Interpretation of the observed mating-type mutations with the help of LEUPOLD's (1958) two-gene scheme.

The boxes represent the closely linked genes *mat1* (on the left) and *mat2* (on the right). The signs +, -, and o, portray the alleles active plus, active minus, and inactive, respectively. The genotypes of the mating types h^{+N} , h^{90} , h^{+R} , and h^{-S} are shown as presented in LEUPOLD's model. h^{-S} is stable. The arrows indicate mutations; the mutations from h^{+R} to h^{-S} and from h^{+N} to h^{90} are shown as postulated by LEUPOLD. The left-hand portion of the Figure illustrates our hypothesis for the incorporation of the new mating type h^{-U} into the scheme via h^{+X} . A second homothallic mating type, h^{90X} , should also exist. Between h^{-U} and h^{+X} , the more frequent mutation is marked by a heavy arrow.

Only those mutations are indicated which are relevant for an interpretation of the reported experiments. Additional mutations would be expected according to this scheme (e.g., from h^{+N} to h^{90X} and *vice versa*, from h^{+X} to h^{+N} , or from h^{90} to a mating type with minus alleles in both genes).

In Figure 1 a hypothetical scheme is presented which accounts for the above points in a logical manner. We suppose that the mating types h^{-U} and h^{+X} have the genotypes $mat1^o mat2^-$ and $mat1^o mat2^+$, respectively. Figure 1 also implies that mutations from h^{+N} and h^{+X} to homothallism on the one hand, and that mutation from h^{-U} to homothallism on the other hand, should result in two different homothallic mating types. h^{90} is the homothallic mating type of LEUPOLD (1958); the hypothetical one has been marked h^{90X} .

Extending LEUPOLD's original postulates, we assumed in Figure 1 the following correlations between phenotype and genotype. (a) Homothallic strains have a + allele at one locus and a - allele at the other, i.e., they are either $mat1^+ mat2^-$ or $mat1^- mat2^+$. (b) Heterothallic + strains have at least one + allele at either

locus and no — allele. (c) Heterothallic — strains have at least one — allele at either locus and no + allele. (For a possible *mat1*⁻ *mat2*⁻ mating type, see text to Figure 1).

Although we assume that *mat1* and *mat2* have similar functions and that each gene independently can determine a heterothallic mating-type reaction, the — alleles as well as the o “alleles” of both loci seem to be different with respect to their mutability. *h*^{-s} strains mutate neither to homothallism nor heterothallism +; therefore, *mat1*⁻ and *mat2*⁰ are stable. According to our hypothesis, this is not true for *mat2*⁻ and *mat1*⁰ since *h*^{-u} strains can mutate to homothallism as well as heterothallism +. Thus, the inactivity in *mat1*⁰ cannot be caused by a deletion as may be the case in *mat2*⁰.

The presented hypothesis can be tested in future recombination experiments. For instance, in crosses *h*^{+R} × *h*^{-u}, crossing over between *mat1* and *mat2* should yield a *h*^{90x} recombinant and a recombinant with two inactive mating-type genes. Spores of the latter genotype, if viable, should give rise to sterile cultures, i.e., cultures which copulate neither with heterothallic + nor — strains. Thus, the new mating type *h*^{-u} is of considerable interest for further analysis of the genetic complexity of the mating-type region as well as of the function performed by the mating-type genes in the regulation of the life cycle of *S. pombe*.

Finally, the described results are only true for spontaneous mating-type mutations in LEUPOLD'S *S. pombe* strains. In experiments with X-rays for which the wild-type strain L975 was used, it was found that about one-fifth of the obtained *ade7* mutants had also mutated from *h*^{+N} to heterothallism — (GUTZ 1961). We retested four of these mutants and found them to be *stable*; the mechanism underlying the induced mutations is not known. Recently we have extended our studies to three additional *S. pombe* strains of different geographical origins. The mating types of the latter strains differ in several aspects from those of LEUPOLD'S cultures; at least one of the strains does not fit into his two-gene scheme (GUTZ and DOE, in preparation).

We thank JAMES H. MEADE for critical reading of the manuscript, and SHIRLEY WALKER for technical assistance.

LITERATURE CITED

- BRESCH, C., G. MÜLLER and R. EGEL, 1968 Genes involved in meiosis and sporulation of a yeast. *Molec. Gen. Genetics* **102**: 301–306.
- GUTZ, H., 1961 Distribution of X-ray- and nitrous acid-induced mutations in the genetic fine structure of the *ade7* locus of *Schizosaccharomyces pombe*. *Nature* **191**: 1125–1126. —, 1971 Site specific induction of gene conversion in *Schizosaccharomyces pombe*. *Genetics* **69**: 317–337.
- LEUPOLD, U., 1950 Die Vererbung von Homothallie und Heterothallie bei *Schizosaccharomyces pombe*. *Compt. Rend. Trav. Lab. Carlsberg, Sér. Physiol.* **24**: 381–480. —, 1955 Methodisches zur Genetik von *Schizosaccharomyces pombe*. *Schweiz. Z. Path. Bakt.* **18**: 1141–1146. —, 1958 Studies on recombination in *Schizosaccharomyces pombe*. *Cold Spring Harb. Symp. Quant. Biol.* **23**: 161–170. —, 1970 Genetical methods for *Schizosaccharomyces pombe*. pp. 169–177. In: *Methods in Cell Physiology*. Vol. 4. Edited by D. M. PRESCOTT. Academic Press, New York and London.
- VON BORSTEL, R. C., 1969 Yeast Genetics Supplement to *Microbial Genetics Bull.* No. 31, Oak Ridge Natl. Laboratory.