

Report

Linkage of Otopalatodigital Syndrome Type 2 (OPD2) to Distal Xq28: Evidence for Allelism with OPD1

Stephen P. Robertson,¹ Sinead Walsh,¹ Michael Oldridge,¹ Tania Gunn,^{2,*} David Becroft,³ and Andrew O. M. Wilkie¹

¹Weatherall Institute of Molecular Medicine, The John Radcliffe Hospital, Oxford, United Kingdom; and ²Department of Paediatrics, National Women's Hospital, and ³Department of Obstetrics and Gynaecology, University of Auckland School of Medicine, Auckland, New Zealand

Otopalatodigital syndrome type 1 (OPD1) is an X-linked semidominant condition characterized by malformations of the skeleton, auditory apparatus, and palate. Previous studies have established linkage to a 16-cM region of Xq27-q28. A proposed allelic variant of OPD1, termed "OPD2," is associated with a more severe, frequently lethal phenotype with visceral and brain anomalies in addition to skeletal, auditory, and palatal defects. We report linkage of the OPD2 phenotype to a 2-cM region of distal Xq28 in a Maori kindred, with a maximum multipoint LOD score of 3.31 between the markers *DXS1073* and *DXS1108*. This provides support for allelism between OPD1 and OPD2 and reduces the size of the disease interval to 1.8–2.1 Mb. We also demonstrate that female carriers of this disorder exhibit skewed inactivation that segregates with the high-risk haplotype and may be inversely related to the severity with which they manifest features of the disorder.

Otopalatodigital syndrome type 1 (OPD1 [MIM 311300]) is an X-linked condition characterized, in affected males, by skeletal abnormalities, conductive or sensorineural hearing loss, and cleft palate (Taybi et al. 1962; Dudding et al. 1967). The skeletal dysplasia comprises camptodactyly, long spatulate fingers, pectus carinatum, mild campomelia, and malformed auditory ossicles—the latter feature leading to conductive hearing loss in some individuals. Carrier females may exhibit the same manifestations as males but generally have a milder range of expressivity. A second entity—comprising a more severe skeletal dysplasia, cleft palate, and micrognathia—was subsequently described (Fitch et al. 1976) and was later designated "otopalatodigital syndrome type 2" (OPD2 [MIM 304120]), owing to its clinical similarity to OPD1 (Fitch et al. 1983). Subsequent reports have extended the phenotype of OPD2 to include cardiac, genitourinary, gastrointestinal, and central nerv-

ous system anomalies. Perinatal death is common because of these malformations, and intellectual disability sometimes occurs, in contrast to OPD1. As in OPD1, carrier females with OPD2 exhibit a phenotype that can extend from a mild subclinical osteodysplasia to a presentation indistinguishable from that of affected males.

Two studies have previously linked OPD1 to the distal portion of the long arm of the X chromosome, between *DXS539* (located in Xq27) and the telomere—a distance of 16 cM (Biancalana et al. 1991; Hoar et al. 1992). No linkage studies have previously been performed on OPD2, and, therefore, no experimental evidence exists to support the clinical hypothesis that these two disorders are allelic.

We have previously ascertained a four-generation family of Maori ancestry from New Zealand that segregates OPD2 (Robertson et al. 1997). Several individuals have been born since the original report, and the updated pedigree is presented in figure 1. Within this family, there have been five affected males, all of whom died perinatally and had a severe skeletal dysplasia with campomelia, thoracic constriction, and digital anomalies. Three of these individuals had an omphalocele, two had cleft palate, and four had genitourinary anomalies. An additional male (III-1) died perinatally of unknown cause. Six females could be identified as carriers, either because they had transmitted the mutant allele (four sub-

Received April 12, 2001; accepted for publication May 11, 2001; electronically published June 6, 2001.

Address for correspondence and reprints: Prof. A.O.M. Wilkie, Weatherall Institute of Molecular Medicine, The John Radcliffe Hospital, Headington, Oxford OX3 9DS, United Kingdom. E-mail: awilkie@molbiol.ox.ac.uk

* Deceased.

© 2001 by The American Society of Human Genetics. All rights reserved. 0002-9297/2001/6901-0024\$02.00

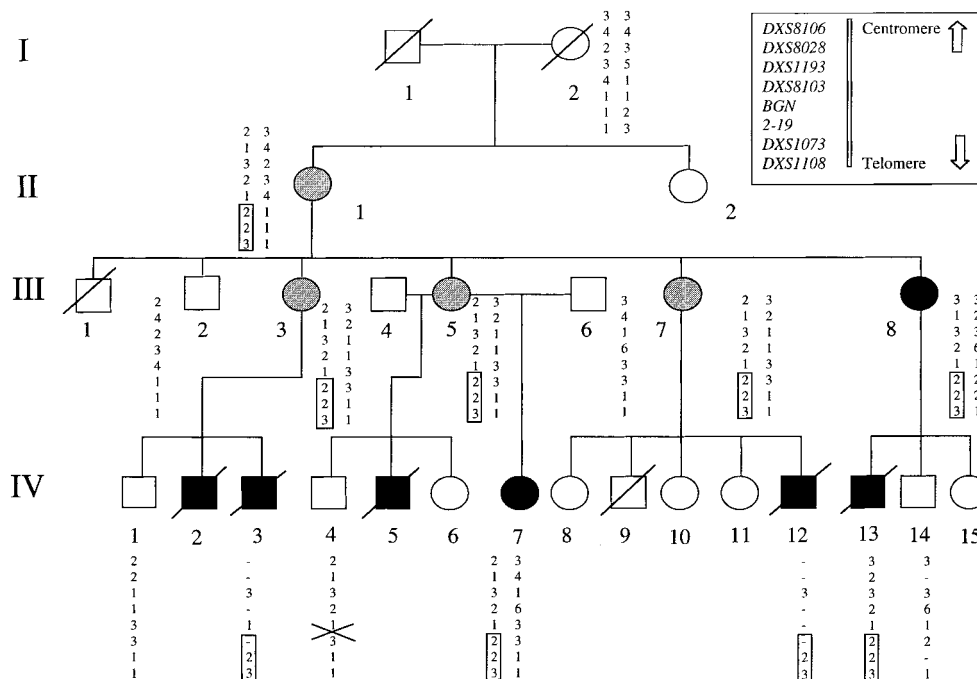

Figure 1 Pedigree of the family segregating for OPD2. *Unblackened circle*, unaffected female; *gray circle*, subclinically affected female; *blackened circles*, clinically manifesting female; and *blackened square*, affected male. Haplotypes are depicted for markers located in the distal region of Xq, and the segment that segregates perfectly with the disease is boxed. Individual III-8 is known to have a different father from her female siblings. Genotypes for the locus *BGN* represent a combination of results obtained from *DXSBGN* and the novel SNP identified in intron 5. The locus *2-19* is a novel marker identified as polymorphic during the course of this study (see text). The position of the key recombination in individual IV-4 is indicated with a cross. The results for clinically unaffected females in generation IV are omitted, to avoid revealing their carrier status.

jects), because they manifested specific features of OPD2 (one subject), or for both reasons (one subject). The specific manifestations were conductive deafness caused by malformed auditory ossicles (III-8) and bilateral hearing loss, cleft palate, spatulate fingers, and a chest wall deformity (IV-7). The four apparently healthy carriers exhibited minor, but consistent, radiological anomalies of the skull base, ribs, vertebral bodies, and long bones. The study was approved by the local institutional ethics committee, and informed consent was given to obtain venous blood, from all available members of the pedigree, and fixed tissue, from autopsy specimens of IV-3 and IV-12. DNA was prepared using standard techniques.

Given the established clinical and pedigree evidence that OPD2 segregates as an X-linked trait, the segregation of a panel of polymorphic markers encompassing the entire X chromosome (Dib et al. 1996) was studied in this family. The data were analyzed using the MLINK and LINKMAP programs from the FASTLINK 4.0 software package (Lathrop and Lalouel 1984; Cottingham et al. 1993; Schäffer et al. 1994), available through the U.K. Human Genome Mapping Project, to obtain two-point and multipoint LOD scores, respectively. The trait

was assigned as X linked, with the penetrance of the disease allele set at 1.0 and with the disease-allele frequency set at .0001. All males and the six females identified as carriers were included in the calculation of the LOD score.

The only markers that yielded significantly positive LOD scores mapped to distal Xq28. Markers *DXS1073* and *DXS1108*, located 1.5 Mb and 0.5 Mb from the telomere, respectively, gave two-point LOD scores of 2.41 and 2.71, respectively, at $\theta = 0$. By multipoint analysis, a maximum LOD score of 3.31 was obtained between markers *DXS1073* and *DXS1108* (fig. 2). Localization to any other region of the X chromosome was excluded, at odds of >100:1 (data not shown). This confirmed that the OPD2 phenotype in this family maps to the same region of the X chromosome as does OPD1, consistent with allelism of the two conditions.

Inspection of haplotypes identified a recombination at *DXS8103* in the unaffected male IV-4, placing the disease locus distal to this marker (fig.1). We evaluated *BGN*, which maps distal to *DXS8103* and encodes the proteoglycan biglycan, as a candidate disease gene (Fisher et al. 1991). However, we identified a previously undescribed single-nucleotide polymorphism (SNP)

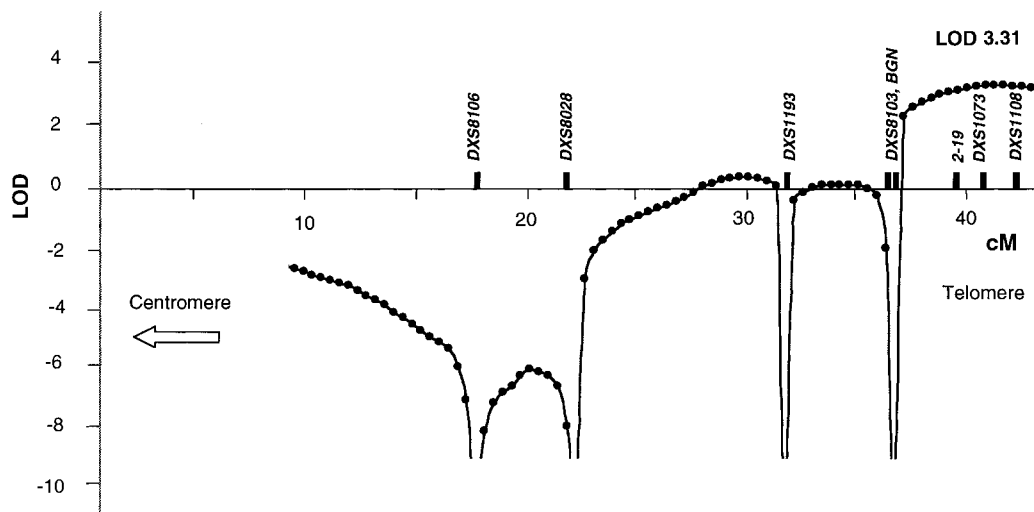

Figure 2 Multipoint LOD analysis of the family, in the region of the Xq telomere

(IVS5+90C→T), for which IV-4 had inherited the same allele that was found in affected individuals IV-3 and IV-7, excluding *BGN* as the disease gene and placing the disease gene distal to this locus (fig. 1).

To refine the linkage interval more precisely, we searched published sequences within the region bounded by *BGN* and *DXS1073*, for repetitive sequences and SNPs. No published SNP or polymorphism was heterozygous in III-5, but we identified three novel polymorphisms that were informative for the critical meiosis. An (AT)_n repeat was positioned 5' to the gene *2-19*, which is located 1.6 Mb from the telomere, and was amplified with the primers 5'-GCAACAAAGTGAGACCCTGC-3' and 5'-GTTGGCTGTGTCAGGTCAGG-3' (GenBank L44140). The second locus, a polyadenine stretch located adjacent to the *TKTL1* gene 1.8 Mb from the telomere, was amplified with the primers 5'-CGTGGTGGCTTACACCTGTC-3' and 5'-ATACCTGCTTTCGTCGGGGCACAC-3' (GenBank Z49258). Both these loci were shown to be nonrecombinant in the unaffected male (IV-4). The disease allele at locus *2-19* originated from the unaffected great-grandfather, I-1, indicating that the mutation arose de novo in patient II-1 (fig. 1). A locus comprising a complex C_nT_n repeat stretching over ~350 bp, lying 1.5 kb 3' to the *L1CAM* gene (GenBank U52112), was also identified as polymorphic. This repeat was amplified initially using the primers 5'-AAGTTCTCACCTTGAAAGTGCAG-3' and 5'-GTAAAAAATCAGGTTGCAGCG-3' and was followed by a second reaction employing primers 5'-AAGTGGAGGGCTCACCTGTG-3' and 5'-CGACAGACGAGACAAAGAAAG-3'. The two alleles in patient III-5 differed in length by a single CT dinucleotide within the repeat, and individual IV-4 was recombinant at this locus. This analysis reduced the OPD2 interval to a maximum of 2.1 Mb (*L1CAM*-Xqter) and a minimum of 1.8 Mb (*TKTL1*-Xqter) (fig. 3).

The terminal 2.1 Mb of Xq has been intensively studied, and much of it is sequenced and characterized in terms of its gene content. Mutations in 12 genes are known to cause specific monogenic disorders, and many additional diseases map to this general region. The density of genes within the candidate interval is uneven; gene-dense segments are found within the proximal 500 kb, but more-distal sequences have been predicted to be relatively gene poor (De Sario et al. 1996). The 400 kb bounded by the telomere, termed the "Xq/Yq homology region," is fully sequenced and encodes four genes and one pseudogene (Ciccodicola et al. 2000). Although all four genes have counterparts on the homologous portion of the Y chromosome, some are inactivated in a Y-spe-

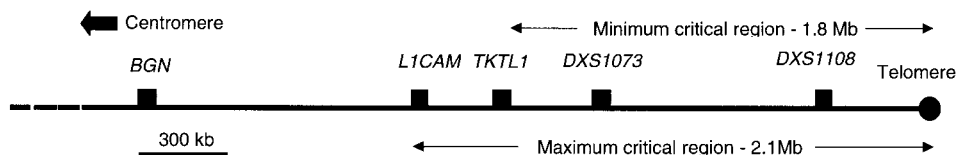

Figure 3 Physical map outlining the position and extent of the candidate interval containing the gene mutated in OPD2

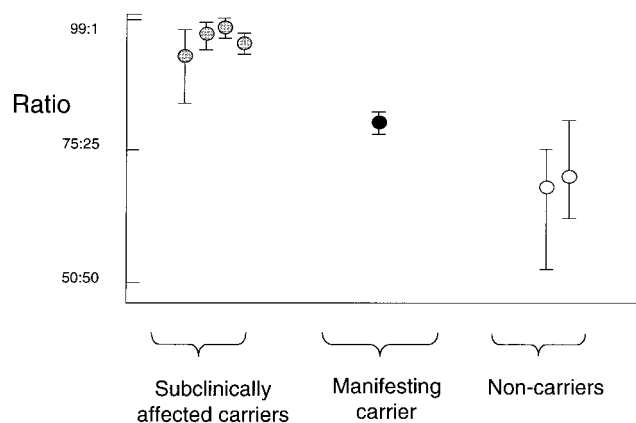

Figure 4 Skewing of X inactivation (relative methylation of alleles at the androgen-receptor locus) in relation to affection status of females in the pedigree. Each symbol marks the mean of three independent experiments, with the range of values obtained shown by a vertical bar. Definitions of symbols are the same as in figure 1, except that two individuals in generation IV, predicted by linkage analysis to be carriers, are represented by gray symbols.

cific manner. This, together with the substantially lower recombination rate compared to that observed for the primary pseudoautosomal region at Xp/Yp, means that these genes remain potential candidates for a disorder such as OPD.

The linkage of OPD2 to a narrow region within the candidate interval previously identified for OPD1 provides the first experimental support for the hypothesis that the two conditions are allelic. Clinical evidence exists to suggest that two other conditions, frontotaphyseal dysplasia (FMD [MIM 305620]) and Melnick-Needles syndrome (MNS [MIM 309350]) may also be allelic to OPD types 1 and 2 (Verloes et al. 2000). FMD segregates as an X-linked semidominant condition and is characterized by skull hyperostosis, digital/skeletal anomalies, and deafness and is therefore reminiscent of OPD1 (Superti-Furga and Gimelli 1987). Affected males born to women with MNS bear striking resemblance to males with OPD2 (Verloes et al. 2000). It is therefore possible that the 1.8–2.1-Mb region that we have identified as the candidate interval for OPD2 contains the gene mutated in all four conditions.

To gain further insight into the expression of the OPD2 disease phenotype in carrier females, we performed X-inactivation studies on DNA extracted from peripheral blood samples. The relative methylation (and, hence, inactivation) of the two alleles of the androgen-receptor CAG repeat was measured by quantifying each allele after digestion of the radiolabeled PCR product by the restriction enzyme *HpaII* (Allen et al. 1992). Band intensity was captured on a phosphoimager screen and was integrated using IMAGEQUANT software, version

5.1 (Molecular Dynamics). Two of the four obligate carriers with only subclinical evidence of their carrier status were informative in this assay and demonstrated >90% inactivation of one allele in blood leucocytes (fig. 4). Individual IV-7, who has a cleft palate, deafness, and moderately severe skeletal findings, was less skewed (80% inactivation of one allele). Individual III-8 with conductive deafness caused by ossicular deformities was uninformative. Two other females in generation IV, who are clinically normal but have not been examined radiologically, are predicted, by linkage analysis, to carry the mutant allele and were also noted to be >90% skewed. Two females (I-2 and another in generation IV), predicted, by linkage analysis, to be noncarriers demonstrated a random X-inactivation pattern (68% and 71%, respectively).

The preponderance of severely skewed individuals in this family is well in excess of the proportion observed in the general population (Sharp et al. 2000). Moreover, skewed X inactivation cosegregates with the OPD2 and high-risk haplotype. The most likely explanation for these observations is that, in carrier females, selection occurs early in embryogenesis, against cells in which the active X chromosome bears the mutant allele, as is documented in several other X-linked disorders (Migeon and Haisley-Royster 1998).

The manifesting female IV-7 showed a less dramatically skewed pattern of X inactivation. Variation in the severity of the female phenotype has been described for both OPD1 (Gall et al. 1972; Gorlin et al. 1973) and OPD2 (Robertson et al. 1997), and these data suggest that variation in the degree of X inactivation may be responsible for these observations, as has been proposed for the X-linked dominant condition Rett syndrome (Amir et al. 2000). Once the causative gene is identified, study of a larger group of unrelated male and female patients with OPD and of its allelic conditions will allow description not only of genotypic but also of epigenetic influences, such as X inactivation, on the phenotypic spectrum observed in these syndromes.

Acknowledgments

We thank the members of the family, for their support for this study; Drs. I. Winship and M. Delatycki, for patient samples; and Dr. S. Twigg, for technical support. Computing facilities for linkage analysis were provided by the U.K. Human Genome Mapping Project Resource Centre. The work was funded by a Nuffield Medical Fellowship (S.P.R.) and the Wellcome Trust (A.O.M.W.).

Electronic-Database Information

Accession numbers and URLs for data in this article are as follows:

GenBank, <http://www.ncbi.nlm.nih.gov/Genbank/index.html> (for primers adjacent to the *L1CAM*, 2-19, and *TKTL1* genes)
 Online Mendelian Inheritance in Man (OMIM), <http://www.ncbi.nlm.nih.gov/Omim/> (for OPD1 [MIM 311300], OPD2 [MIM 304120], FMD [MIM 305620], and MNS [MIM 309350])

References

- Allen RC, Zoghbi HY, Moseley AB, Rosenblatt HM, Belmont JW (1992) Methylation of *HpaII* and *HbaI* sites near the polymorphic CAG repeat in the human androgen-receptor gene correlates with X chromosome inactivation. *Am J Hum Genet* 51:1229–1239
- Amir RE, Van den Veyver IB, Schultz R, Malicki DM, Tran CQ, Dahle EJ, Philippi A, Timar L, Percy AK, Motil KJ, Lichtarge O, Smith EO, Glaze DG, Zoghbi HY (2000) Influence of mutation type and X chromosome inactivation on Rett syndrome phenotypes. *Ann Neurol* 47:670–679
- Biancalana V, le Marec B, Odent S, van den Hurk JA, Hanauer A (1991) Oto-palato-digital syndrome type1: further evidence for assignment of the locus to Xq28. *Hum Genet* 88:228–230
- Ciccodicola A, D'Esposito M, Esposito T, Gianfrancesco F, Migliaccio C, Miano MG, Matarazzo MR, Vacca M, Franzè A, Cuccurese M, Cocchia M, Curci A, Terracciano A, Torino A, Cocchia S, Mercadante G, Pannone E, Archidiacono N, Rocchi M, Schlessinger D, D'Urso M (2000) Differentially regulated and evolved genes in the fully sequenced Xq/Yq pseudoautosomal region. *Hum Mol Genet* 9:395–401
- Cottingham RW Jr, Idury RM, Schäffer AA (1993) Faster sequential genetic linkage computations. *Am J Hum Genet* 53:252–263
- De Sario A, Geigl E-M, Palmieri G, D'Urso M, Bernardi G (1996) A compositional map of human chromosome band Xq28. *Proc Natl Acad Sci USA* 93:1298–1302
- Dib C, Faure S, Fizames C, Samson D, Drouot N, Vignal A, Millasseau P, Marc S, Hazan J, Seboun E, Lathrop M, Gyapay G, Morissette J, Weissenbach J (1996) A comprehensive genetic map of the human genome based on 5,264 microsatellites. *Nature* 380:152–154
- Dudding BA, Gorlin RJ, Langer LO (1967) The oto-palato-digital syndrome: a new symptom complex consisting of deafness, dwarfism, cleft palate, characteristic facies, and a generalized bone dysplasia. *Am J Dis Child* 113:214–221
- Fisher LW, Heegaard A-M, Vetter U, Vogel W, Just W, Termine JD, Young MF (1991) Human biglycan gene: putative promoter, intron-exon junctions, and chromosomal localization. *J Biol Chem* 266:14371–14377
- Fitch N, Jequier S, Gorlin R (1983) The otopalatodigital syndrome, proposed type II. *Am J Med Genet* 15:655–664
- Fitch N, Jequier S, Papageorgiou A (1976) A familial syndrome of cranial, facial, oral and limb anomalies. *Clin Genet* 10:226–231
- Gall JC, Stern AM, Poznanski AK, Garn SM, Weinstein ED, Hayward JR (1972) Oto-palato-digital syndrome: comparison of clinical and radiographic manifestations in males and females. *Am J Hum Genet* 24:24–36
- Gorlin R, Poznanski A, Hendon I (1973) The oto-palato-digital (OPD) syndrome in females. *Oral Surg Oral Med Oral Pathol* 35:218–224
- Hoar DI, Field LL, Beards F, Hoganson G, Rollnick B, Hoo JJ (1992) Tentative assignment of gene for otopalatodigital syndrome to distal Xq(Xq26-28). *Am J Med Genet* 42:170–172
- Lathrop GM, Lalouel JM (1984) Easy calculation of lod scores and genetic risks on small computers. *Am J Hum Genet* 36:460–465
- Migeon BR, Haisley-Royster C (1998) Familial skewed X inactivation and X-linked mutations: unbalanced X inactivation is a powerful means to ascertain X-linked genes that affect cell proliferation. *Am J Hum Genet* 62:1555–1557
- Robertson S, Gunn T, Allen B, Chapman C, Becroft D (1997) Are Melnick-Needles syndrome and otopalatodigital syndrome type II allelic? observations in a four generation kindred. *Am J Med Genet* 71:341–347
- Schäffer AA, Gupta SK, Shriram K, Cottingham RW (1994) Avoiding recomputation in linkage analysis. *Hum Hered* 44:225–237
- Sharp A, Robinson D, Jacobs P (2000) Age- and tissue-specific variation of X chromosome inactivation ratios in normal women. *Hum Genet* 107:343–349
- Superti-Furga A, Gimelli F (1987) Fronto-metaphyseal dysplasia and the oto-palato-digital syndrome. *Dysmorph Clin Genet* 1:2–5
- Taybi H (1962) Generalized skeletal dysplasia with multiple anomalies: a note on Pyle's disease. *Am J Roentgen* 88:450–457
- Verloes A, Lesenfants S, Barr M, Grange DK, Journel H, Lombet J, Mortier G, Roeder E (2000) Fronto-otopalatodigital osteodysplasia: clinical evidence for a single entity encompassing Melnick-Needles syndrome, otopalatodigital syndrome types 1 and 2, and frontometaphyseal dysplasia. *Am J Med Genet* 90:407–422