

Computer simulation of energy migration in the C-phycoerythrin of the blue-green algae *Agmenellum Quadruplicatum*

Andrey A. Demidov* and Alexander Yu. Borisov†

*Physics Department; and †Photosynthesis Laboratory of the A. N. Belozersky Institute of Physical and Chemical Biology, Moscow State University, 119899 Moscow, Russia

ABSTRACT Two methods for simulation of energy migration in the C-phycoerythrin fragments of PBS were developed. Both methods are based on the statistical analysis of an excitation behavior in modeling complexes with a limited number (up to hundreds) of chromophores using the Monte-Carlo approach and calculation of migration rates for the system of linear balance equations. Energy migration rates were calculated in the case of C-phycoerythrin of the blue-green algae *Agmenellum quadruplicatum*. The main channels of energy migration were determined in a monomer, trimer, hexamer, and in the rods consisting of 2–4 hexamers. The influence of the "screw" angle between two adjoining trimers of hexamer on the rates of energy migration and on its efficiencies in 1–4 hexamers was also estimated. The analysis was made for the average (random) and real orientation of chromophores in the C-phycoerythrin. For both cases the optimal angle values were determined and the one for real C-phycoerythrin structure was found to be very close ($\Delta\phi \leq 5^\circ$) to the optimal angle calculated.

INTRODUCTION

Some of the actively investigated photosynthetic complexes are phycobiliproteins and phycobilisomes (PBS)–protein complexes with covalently linked chromophores. They are involved in the process of additional energy absorption and migration to chlorophyll molecules of light-harvesting antenna (LHA) of photosynthetic organisms. The efficiency of this process can reach 90%. Present concepts of these objects are described in comprehensive reviews by Glazer (1984), Gantt (1981), Cohen-Bazire and Bryant (1982), MacColl and Guard-Friar (1987), Scheer (1981), Zilinskas and Greenwald (1986), Zuber (1987), Holzwarth (1986), Berns and MacColl (1989).

An impressive success has been achieved in biochemical preparation of PBS as well as of their subunits (see reviews cited above). It offers favorable conditions for step-by-step investigations of the whole PBS complex starting from the level of subunits. Modern physical methods like hole-burning (Köhler et al., 1988) have furnished interesting information about the inhomogeneity of PBS. Electron microscopy (Mörschel et al., 1980) and x-ray spectroscopy (Hackert et al., 1977; Fisher et al., 1980; Schirmer et al., 1985, 1987) have provided rather detailed information on the microstructure of phycobiliproteins including positions and orientations of their chromophores. In particular, Schirmer et al. (1985, 1987) have determined with the resolution of 2.1–2.5 Å the C-phycoerythrin (C-PC) structure of the blue-green algae *Mastigocladus laminosus* and *Agmenellum quadruplicatum*, and orientations of $\alpha 84$, $\beta 84$, and $\beta 155$ chromophores in its α - and β -subunits.

Phycobiliproteins and PBS are very advantageous models for a picosecond investigation of energy migration.

a) The rates of interchromophores energy migration in phycobiliproteins and PBS can easily be determined by a modern picosecond laser technique. For example, the works by Porter et al. (1978), Pellegrino et al. (1981), Suter et al. (1984), and Holzwarth (1986) have disclosed that the time of energy migration along the C-PC rods is within 24–130 ps.

b) The Stokes shift in the same chromophores is about 20–25 nm, with the halfwidth of the absorption and fluorescence spectra being about 15 nm (Mimuro et al., 1986; Sauer et al., 1987, 1988; Glazer et al., 1973; Schneider et al., 1988; Siebzehnrübl et al., 1987).

c) Spectral shifts between different types of chromophores are of the same value.

All these factors have determined the efficiency of picosecond investigations of C-PC in the spectral-time mode—Holzwarth et al. (1987), Schneider et al. (1988), Hanzlik et al. (1985), Wendler et al. (1986); and in the spectral-time-anisotropy mode—Hefferle et al. (1984a, b), Sandström et al. (1988).

Picosecond studies of monomers, trimers, and hexamers of C-PC have shown that their fluorescence decay kinetics may be described by three–four exponentials with specific fast (τ_{fast}) and slow (τ_{slow}) components (Holzwarth et al., 1983, 1987; Kobayashi et al., 1979; Sandström et al., 1988; Wendler et al., 1986; Malak and MacColl, 1991; Schneider et al., 1988). The slow component ($\tau_{\text{slow}} \sim 1.4$ –2 ns) is determined by the fluorescence decay time of separate chromophores, while the fast component—by energy migration from the shortwavelength (sensitizing) "s"-chromophores to the longwavelength (fluorescing) "f"-chromophores. The idea of sensitizing

Address correspondence to Dr. Andrey A. Demidov, Physics Department, Quantum Radiophysics Research Center, Moscow State University—Lenin Hills Complex, 119899 Moscow, Russia.

and fluorescing chromophores in phycobiliproteins was suggested by Dale and Teale (1970) and now it has been widely accepted (see reviews above). In the case of C-PC, the "s"-chromophores are the $\beta 155$ chromophores and the "f"-chromophores are the $\beta 84$ chromophores or a pair of the $\alpha 84$ - $\beta 84$ chromophores (Berns and MacColl, 1989; Schirmer et al., 1985, 1987; Holzwarth et al., 1987; Mimuro et al., 1986; Sauer et al., 1987, 1988).

The lifetime of the fast component depends on the aggregation of C-phycobiliproteins. For example, the following lifetime values were obtained for the set: monomer (τ_m):trimer (τ_t):hexamer (τ_h)— $\tau_m:\tau_t:\tau_h = 85:56:32$ ps (Kobayashi et al., 1979); $\tau_h = 15$ ps (Holzwarth et al., 1983); $\tau_t = 36$ ps (Wendler et al., 1986); $\tau_m:\tau_t:\tau_h = 50:36:10$ ps (Holzwarth et al., 1987); $\tau_m:\tau_t = 57:27$ ps (Sandström et al., 1988).

The energy migration rates in the C-PC hexamers have been calculated by Sauer et al. (1987, 1988) for all chromophore pairs in the C-PC on the basis of the Förster theory and structural data of Schirmer et al. (1985, 1987). Besides, they proposed a method for calculations of dynamics of chromophore excitation in different types of chromophores. The calculations were made for the C-PC monomers, trimers, and hexamers.

Below we have focused our efforts on the following problems that remain yet unsolved: a) determination of the energy migration rates between neighboring hexamers; b) determination of the main routes of energy transfer in the rods consisting of a few C-PC hexamers; c) whether the position and orientation of the C-PC chromophores are optimal for energy migration.

METHODS

For complexes of chromophores with a limited number of molecules it is more correct to use statistical methods of calculation (rather than diffusion approximation) which enable one to take into account the individual features of every molecule and their interconnections (at least those involving the nearest neighboring molecules). The method of balance equations used in the works by Sauer et al. (1987, 1988) is one example of such an approach. Another one is the Monte-Carlo method (Agranovich et al., 1980; Sherstnev et al., 1972; Demidov, 1987, 1988a, b, 1989). In some cases the Monte-Carlo method is preferable because it gives more information about the object, for example, statistics of exciton jumping times, time dependence of "constants" of the energy migration rates (Demidov, 1987, 1988a, b, 1989), but it requires more computer time. In our work we have used both methods.

1. The method of computing of average rates of interchromophore energy migration

In the works by Sauer et al. (1987, 1988) the authors have first solved N linear differential equations for N chromophores of C-PC and then averaged the solutions for three chromophore spectral groups ($\alpha 84$, $\beta 84$, and $\beta 155$ chromophore types). It can be proved that such an approach is, practically, adequate to another procedure when one first groups and averages the pair chromophore-chromophore energy migration rates in three groups and, then, proceeds to a solution of the

system of linear differential equations for these groups. Fortunately such a system consists of only three equations.

The main idea of our approach (Demidov, 1987, 1988a, b, 1989) is as follows. Suppose (like in C-PC) one deals with the three-type chromophore molecular complexes. Let each complex contain N chromophores of the 1st type and M chromophores of the 2nd type; the distance between the i chromophore of the 1st type ($i = 1, \dots, N$) and j chromophore of the 2nd type ($j = 1, \dots, M$) is equal to R_{ij} . Then, at the time t the rate of energy transfer from the i chromophore to all the chromophores of the 2nd type will be equal:

$$K_i^{(2)}(t) = \frac{1}{\tau_0^{(1)}} \sum_{j=1}^M \left[\frac{R_0^{(12)}}{R_{ij}} \right]^6 g(i, t). \quad (1)$$

In this formula the Förster mechanism is involved; $\tau_0^{(1)}$ is the radiation decay time of a free donor (1st type molecules); $R_0^{(12)}$ is the averaged Förster radius of the energy transfer from the chromophores of the 1st type to the chromophores of the 2nd type; $g(i, t)$ is a special function reflected a probability to find exciton at the i -chromophore in a moment t .

After the averaging procedure, we obtain the overall rate of energy migration from chromophores of the 1st type to the chromophores of the 2nd type:

$$K_{12}(t) = \frac{1}{N} \sum_{i=1}^N K_i^{(2)}(t) = \frac{1}{\tau_0^{(1)}} \frac{1}{N} \sum_{i=1}^N \sum_{j=1}^M \left[\frac{R_0^{(12)}}{R_{ij}} \right]^6 g(i, t). \quad (2)$$

For energy migration among the chromophores of the same type (for example, the 1st type) we have:

$$K_{11}(t) = \frac{1}{\tau_0^{(1)}} \frac{1}{N} \sum_{i=1}^N \sum_{\substack{k=1 \\ k \neq i}}^N \left[\frac{R_0^{(11)}}{R_{ik}} \right]^6 g(i, t). \quad (3)$$

Using the Monte-Carlo method (see below) we checked that in our particular case of the C-phycocyanin $g(i, t) \cong 1$ for any i and t and $K_{ij}(t) \cong K_{ij}(t=0)$. It is a common situation for natural organic complexes. But it is necessary to take into account that in the case of some specific spatial structure it is impossible to eliminate the $g(i, t)$ -function, which can lead to some interesting phenomena as dependence of rate parameters on the time (Demidov, 1988a).

Kinetic processes in our particular complex comprising three types of chromophores are described by the system of three linear equations:

$$\begin{aligned} \frac{dn_1}{dt} &= -\frac{n_1}{\tau_1} - K_{12}n_1 - K_{13}n_1 + K_{21}n_2 + K_{31}n_3 \\ \frac{dn_2}{dt} &= -\frac{n_2}{\tau_2} - K_{21}n_2 - K_{23}n_2 + K_{12}n_1 + K_{32}n_3 \\ \frac{dn_3}{dt} &= -\frac{n_3}{\tau_3} - K_{31}n_3 - K_{32}n_3 + K_{13}n_1 + K_{23}n_2, \end{aligned} \quad (4)$$

where τ_1 , τ_2 , and τ_3 are the excitation decay times of the free molecules of the 1st, 2nd, and 3rd types; n_1 , n_2 , and n_3 are populations of the excited states of these chromophores.

2. Monte-Carlo method

We used the Monte-Carlo approach of numeric analysis of exciton random walking between various chromophores. At each moment, the probability of exciton jumping from one chromophore to all others is estimated, and in accordance with this estimation an exciton either jumps to another chromophore or converts to heat or fluorescence quantum. Then the whole analysis is repeated again if there is an exciton jumping. After statistical averaging over a great number of excitons (commonly $\geq 10^4$), one can obtain precise macroscopic parameters ade-

TABLE 1 Rates of energy migration among C-PC chromophores (ns⁻¹)

DONOR	ACCEPTOR					
	Random Orientation			Real Orientation		
	$\alpha 84$	$\beta 84$	$\beta 155$	$\alpha 84$	$\beta 84$	$\beta 155$
<i>monomer</i>						
$\alpha 84$	0	2.83	1.72	0	12.4	0.445
$\beta 84$	2.39	0	8.52	10.5	0	7.54
$\beta 155$	7.84	38.5	0	2.04	34.1	0
<i>trimer</i>						
$\alpha 84$	1.13	583	7.73	2.28	1400	0.951
$\beta 84$	493	27.2	9.81	1180	18.8	7.87
$\beta 155$	33.5	44.3	0.366	4.36	35.6	0.584
<i>hexamer</i>						
$\alpha 84$	215	611	17.2	361	1430	16.4
$\beta 84$	516	47.5	12.3	1210	43.8	10.9
$\beta 155$	79	55.4	92.8	75	49.5	195
<i>two hexamer rod</i>						
$\alpha 84$	227	623	18.1	370	1440	16.6
$\beta 84$	525	106	12.8	1220	129	11.5
$\beta 155$	83.4	59.6	95.8	77.2	53.5	198
<i>four hexamer rod</i>						
$\alpha 84$	233	629	18.5	375	1450	16.7
$\beta 84$	529	134	13.1	1220	171	11.8
$\beta 155$	85.3	61	97.2	77.3	54.6	199

quate to experimental data, because the Monte-Carlo method is based on microscopic analysis of the individual behavior of excitons.

In the present work, for investigation of the energy migration in C-PC, we have used the Monte-Carlo computer program developed by Demidov (1987, 1988a, b, 1989) and adapted to the analysis of C-PC. The program was written in FORTRAN-77, the program volume was about 42 KBytes, and the calculations were made by means of an IBM-AT computer.

OBJECT OF INVESTIGATION

We have studied C-PC of the blue-green algae *Agmenellum quadruplicatum* in which coordinates and orientations of chromophores were determined by Schirmer et al. (1985, 1987). We used this data in our calculations and we assumed that all C-PC rods consisted of similar C-PC hexamers.

We have borrowed the spectral and lifetime parameters of chromophores from the works by Sauer et al. (1987, 1988). In these works the authors assumed that all chromophores have equal fluorescence lifetimes $\tau = 1.5$ ns and corresponding quantum yields of fluorescence ($\tau = \tau_0 \Phi$): $\Phi_{\alpha 84} : \Phi_{\beta 84} : \Phi_{\beta 155} = 0.72 : 0.48 : 0.72$. They have also calculated the matrix of overlapping integrals $a_{ij} =$

$\int f_i(\nu) \epsilon_j(\nu) \nu^{-4} d\nu$, where $f_i(\nu)$ is the normalized fluorescence spectrum of donor i and $\epsilon_j(\nu)$ is an absorption spectrum of acceptor j .

By using the results by Sauer et al. (1987, 1988) for averaged mutual orientations of molecules ($x^2 = 2/3$) one can calculate the Förster radius for $\alpha 84 \rightarrow \alpha 84$ homogeneous energy transfer— $R_0^{\alpha 84} = R_0^{(11)} = 71 \text{ \AA}$. For Förster radius in the cases of heterogeneous donor-acceptor pairs, the theory provides (Förster, 1948):

$$R_0^{(ij)} = R_0^{(11)} \left[\frac{a_{ij}}{a_{11}} \right]^{1/6} \quad i, j = 1, 2, 3. \quad (5)$$

RESULTS AND DISCUSSION

In Table 1 the energy migration rates are presented. Calculations were made by us for monomers, trimers, hexamers, and rods consisting of two and four hexamers. These calculations were conducted for two cases: (a) "averaged" orientation of chromophores—orientation factor $x^2 = 2/3$; (b) real orientation of chromophores (Schirmer et al., 1985, 1987)— $x^2 = [\cos(\alpha) - 3 \cos(\beta_1) \cos(\beta_2)]^2$, where α is the angle between dipoles of donor and acceptor chromophores; and β_1 and β_2 are the angles between the chromophore dipoles and the radius-vector connecting them.

In these calculations, we accepted the "screw" angle between the upper and lower trimers equal to $\phi_0 \cong 13.5^\circ$ in accordance with the data by Schirmer et al. (1985, 1987). The data presented in Table 1 enable one to calculate both the kinetics of energy migration and the kinetics of fluorescence decay by using the formulae (4).

Some important conclusions can be derived from comparison of the left and right columns of Table 1. One can see that in the case of real chromophore positions (*right column*) the energy migration rates are approximately two-times larger than those for the "averaged" values of

TABLE 2 Rates of energy migration between C-PC trimers and hexamers (ns⁻¹), per Fig. 1

DONOR	ACCEPTOR					
	Random Orientation			Real Orientation		
	$\alpha 84$	$\beta 84$	$\beta 155$	$\alpha 84$	$\beta 84$	$\beta 155$
<i>between trimers I and 2 of hexamers I and II</i>						
$\alpha 84$	214	27.6	9.51	385	34.8	15.4
$\beta 84$	22.6	20.3	2.46	32.7	25	3.08
$\beta 155$	43.6	11.1	92.4	70.7	13.9	194
<i>between hexamers I and II</i>						
$\alpha 84$	23.6	23.1	1.73	22.1	8.99	0.55
$\beta 84$	18.9	115	1.46	9.93	170	1.57
$\beta 155$	7.92	6.61	4.49	2.53	7.06	1.37

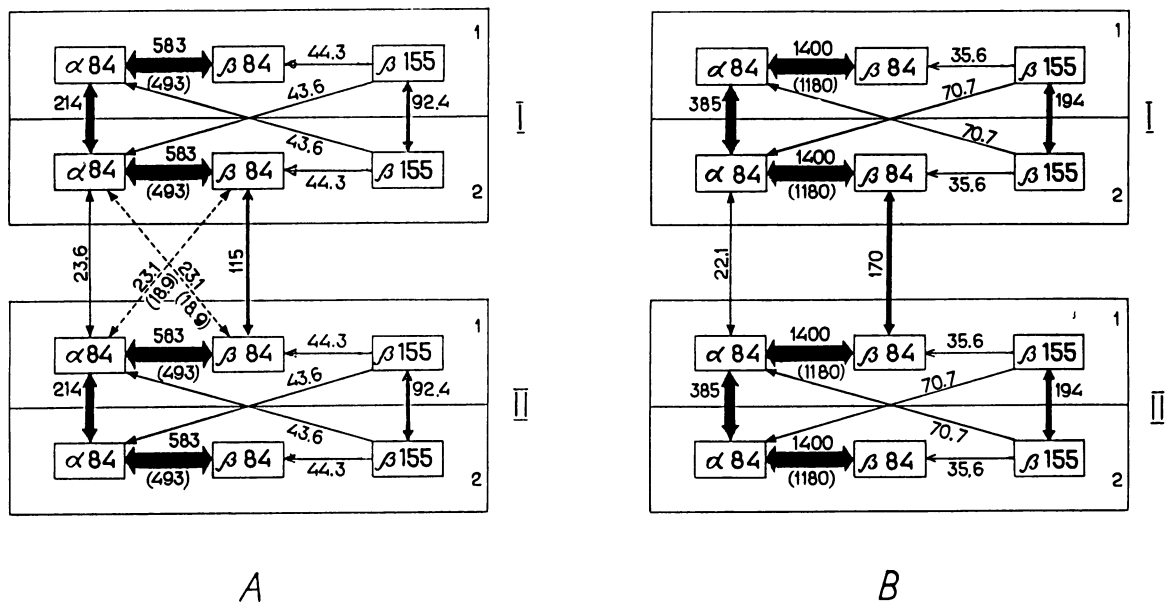

FIGURE 1 Simplified schemes of the main channels of energy migration in C-phycoerythrin: (1a) - average (random), (1b) - real (data by Schirmer et al. (1985, 1987)) orientation of chromophores. Presented in the diagrams are two hexamers (I and II), each consisting of two trimers (1 and 2). Direct and reverse (in brackets) rates are given in ns^{-1} .

the orientation coefficient. In addition, some information on energy transfer between chromophores and their groups within the trimers and hexamers was obtained. Corresponding results are presented in Table 2 and schematically in Fig. 1. Table 2 contains complete information on the energy migration rates among hexamers I and II (see Fig. 1) and trimers 1 and 2 of these hexamers. Fig. 1 illustrates qualitatively the main channels of energy migration.

Analysis of the data presented in the above tables shows the main routes of energy migration in the C-PC. Sensitizing chromophores β 155 pass on their energy to the β 84 chromophores of the same trimer and to the α 84 chromophores of the next trimer of the same hexamer. In each trimer there is a strong coupling between α 84 and β 84 chromophores. From this pair, energy passes to the neighboring trimer through the α 84 \rightarrow α 84 channel. Moreover, there is a powerful energy flow from one trimer to another (in hexamer) through the channel β 155 \rightarrow β 155. The main channel of energy migration between hexamers is the channel β 84 \rightarrow β 84. It looks likely that this channel is the "narrowest" path of the whole energy migration through the C-PC rod that limits the whole energy flow. The weaker paths of energy migration are not shown in Fig. 1. They involve 10–20% of the whole excitation flow, at most.

The upper trimer in hexamer is known to be screwed against the lower trimer by the angle $\phi_0 \cong 13.5^\circ$. It means that if chromophores of the upper trimer have coordinates $\{z\}$, $\{r\}$, and $\{\phi\}$, then appropriate chromophores of the lower trimer will have coordinates $\{-z + z_0\}$, $\{r\}$, and $\{-\phi + \phi_0\}$, where z_0 is a global shift

of the lower trimer relative to the upper trimer along the Z-axis, and ϕ_0 is a "screw" angle of one trimer relative to another one around the Z-axis. This pattern is well documented in the works by Schirmer et al. (1985, 1987), Sauer et al. (1987, 1988), Mimuro et al. (1986).

Now we face the question: What is the reason that Nature has created this particular chromophore arrangement, and whether energy migration between trimers and hexamers and, correspondingly, in the whole C-PC rods is optimal?

We analyzed the influence of screw-angle $\Delta\phi$ relative to the angle $\phi_0 \cong 13.5^\circ$ on the efficiency of energy migration in C-PC. Some results of our calculations are shown in Figs. 2–6. From these figures one can well see the dependence of the interchromophore energy migration rates on the screw-angle $\Delta\phi$.

Two cases of chromophore orientation (random and oriented) differ both in shape and position of the optimal energy pass, and, besides, each energy channel has its own optimal angle.

One can see that the main route of energy transfer between the trimers is associated with the α 84 \rightarrow α 84 channel. It reaches maximum at the $\Delta\phi \cong -3.4^\circ$ (oriented chromophores). The main channel of energy migration between hexamers β 84 \rightarrow β 84 has its maximum at the $\Delta\phi \cong -10^\circ$. Fig. 4 shows a remarkable dependence of energy migration between the β 155 chromophores of the upper and lower trimers of one hexamer with its maximum at the angle $\Delta\phi \sim -25^\circ$ ($K \sim 6.5 \text{ ps}^{-1}$). At that angle a very strong energy coupling might occur between the upper and lower β 155 chromophores within hexamers, but between different hexamers the energy

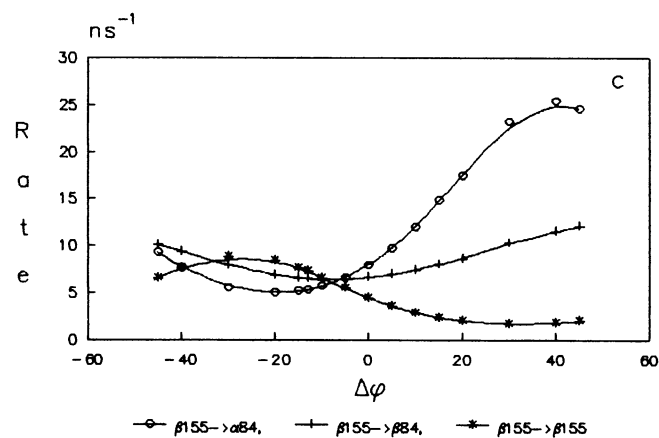
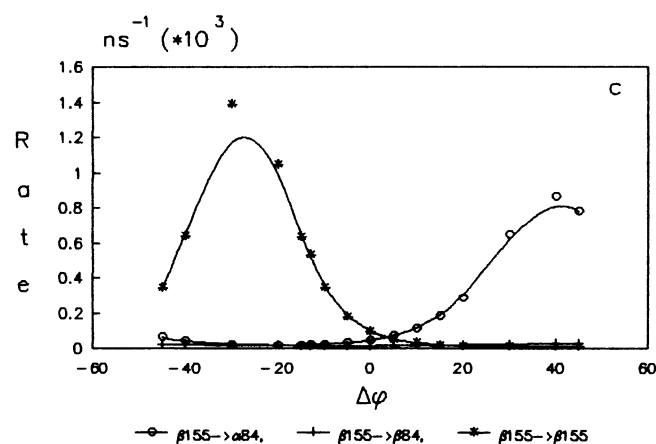
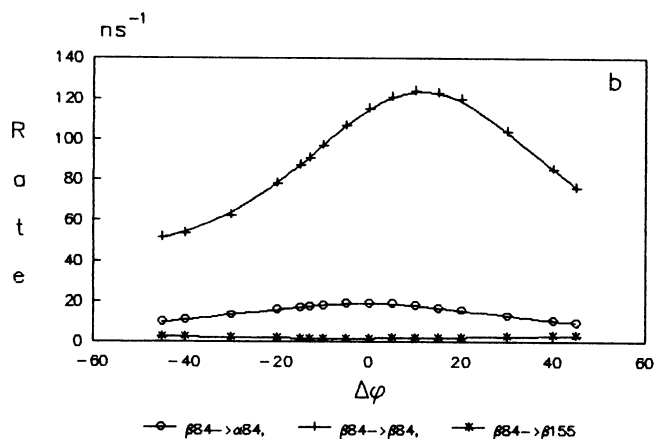
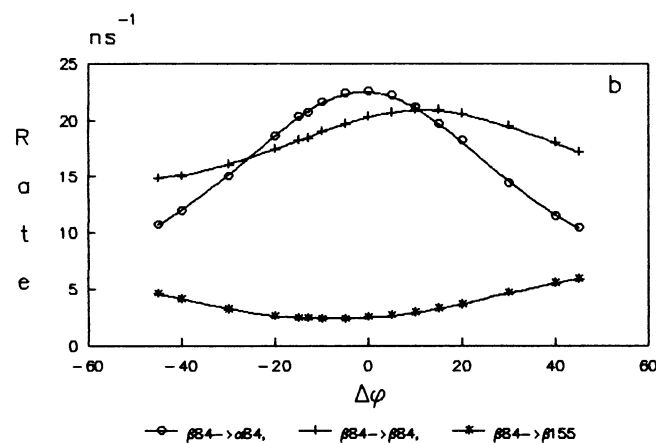
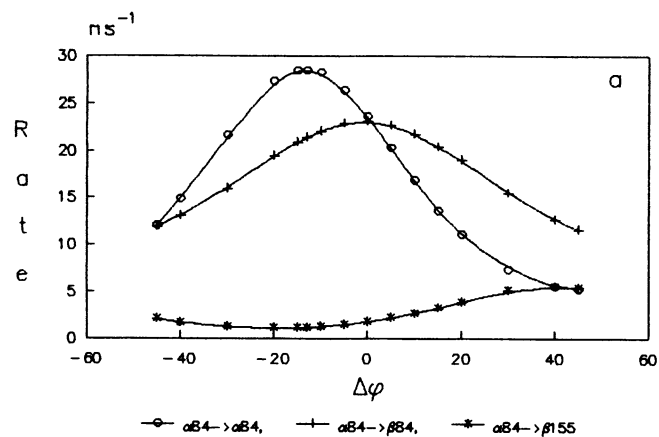
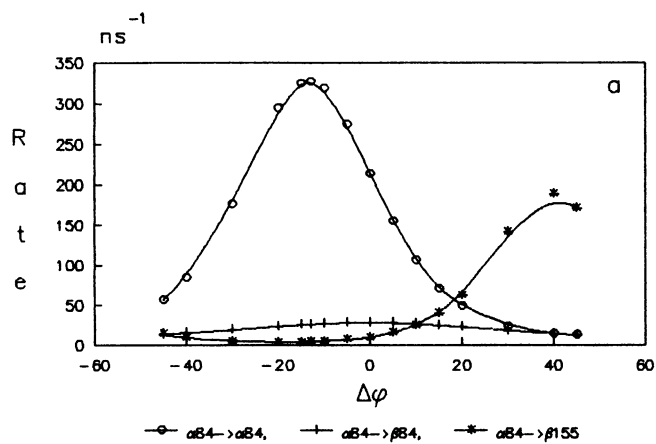

FIGURE 2 Graphs of energy migration rates between chromophores of trimers '1' and '2' (see Fig. 1) versus the screw angle $\Delta\phi$ (around Z-axis) of one trimer relative to the other in case of random (average) orientation of chromophores; (a) energy transfer from $\alpha 84$, (b) energy transfer from $\beta 84$, (c) transfer from $\beta 155$.

FIGURE 3 Graphs of energy migration rates between chromophores of trimer '2' of hexamer 'I' and trimer '1' of hexamer 'II' (see Fig. 1) versus the screw angle $\Delta\phi$ (around Z-axis) of upper and lower trimers ('1' and '2') one relative to the other inside both hexamers in case of random (average) orientation of chromophores; (a) transfer from $\alpha 84$, (b) transfer from $\beta 84$, (c) transfer from $\beta 155$.

flow is weak. Therefore, this conformation, as a whole, is not optimal for energy migration through the C-PC rod.

The above analysis has yielded dependencies of the

interchromophore rates of energy migration on $\Delta\phi$ angle, but still we do not have information about the total efficiency of energy transfer through C-PC rods consist-

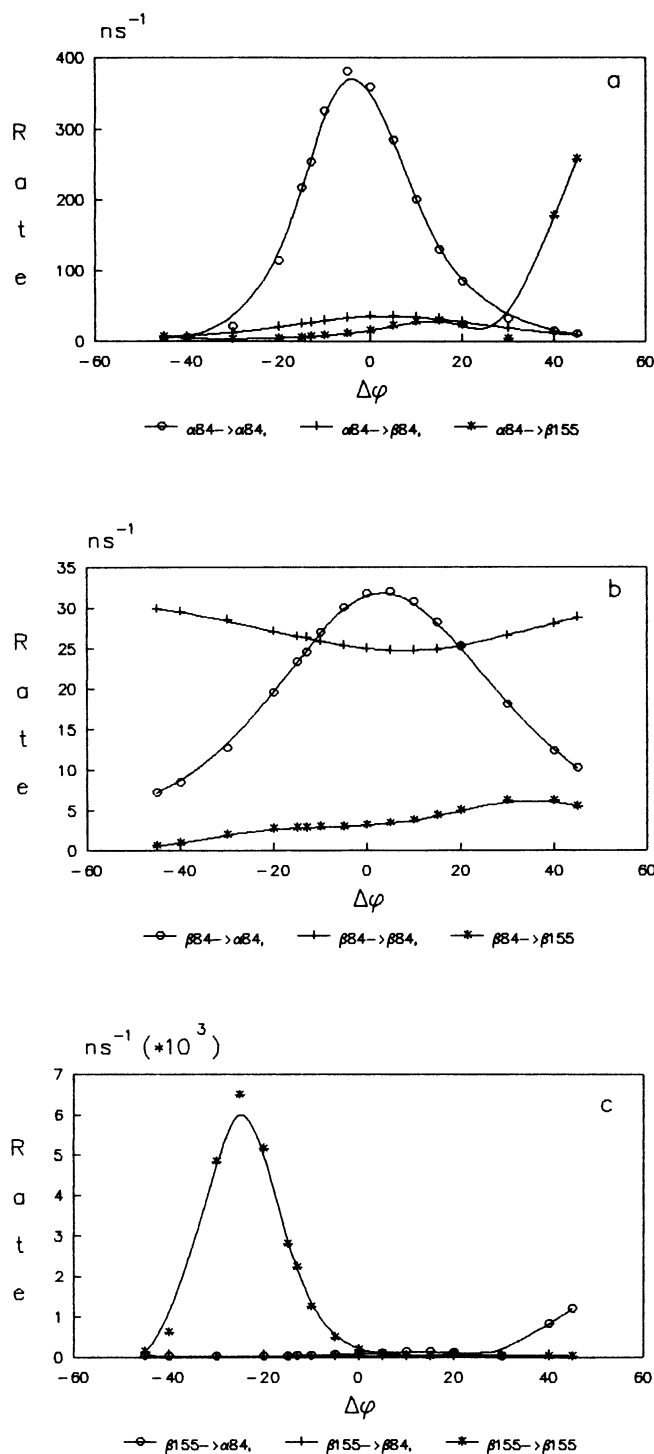

FIGURE 4 Graphs of energy migration rates between chromophores of trimers '1' and '2' (see Fig. 1) versus the screw angle $\Delta\phi$ (around Z-axis) of one trimer relative to the other in case of real orientation of chromophores; (a) transfer from $\alpha 84$, (b) transfer from $\beta 84$, (c) transfer from $\beta 155$.

ing of several hexamers. In order to solve this problem, we have used the Monte-Carlo method for simulation of excitation random walks in the C-PC rod consisting of

four hexamers. *In vivo* after reaching the terminal trimer of the C-PC rod excitation is mostly "trapped" by allophycocyanin. In order to simulate this process we have arbitrarily assumed that, in the terminal trimer at the one side of rod the chromophores $\alpha 84$, $\beta 84$, $\beta 155$, either separately or all together, function as absolute traps. It means that these chromophores have very large quenching constants.¹

We have also assumed that light photons are equally absorbed by all chromophores and that excitations thus created can decay in one of three ways: intrachromophore fluorescence (k_f), conversion into triplet and heat (k_{ST} , k_h) or migration and trapping in the terminal trimer (k_{tr}). The lifetime of exciton τ_{tr} in the presence of traps represents a quantitative parameter of the overall energy migration efficiency (η) along the rod:

$$\eta = \frac{\tau}{\tau_{tr}} = \frac{(k_f + k_{ST} + k_h)^{-1}}{(k_f + k_{ST} + k_h + k_{tr})^{-1}},$$

where $\tau = 1.5$ ns.

Fig. 6 represents the dependence of energy migration efficiency η on the screw-angle $\Delta\phi$. This dependence has a more sharpened profile in the case of oriented chromophores than in the case of randomly oriented chromophores. In the former case the efficiency η at $\Delta\phi = 0$ is about 1.3 times greater than in the latter case. Two curves ($\alpha 84$ -trap and $\beta 84$ -trap) have practically the same shape (Fig. 6 b) due to very strong coupling between corresponding $\alpha 84$ and $\beta 84$ chromophores in trimer ($K \sim 1.2$ – 1.4 ps^{-1} , see Fig. 1 b). As for the $\beta 155$ chromophores, they have almost no chance to serve as a trap in real PBS.

Thus, the data in Fig. 6 prove that regardless of which $\alpha 84$ or $\beta 84$ chromophore serves in real PBS as the major intermediate of energy migration to the allophycocyanin, there is an optimum of efficiency of energy migration along the C-PC rods within the screw-angle $0^\circ \leq \Delta\phi \leq -5^\circ$. It is practically coincident with the real *in vivo* angle ($\Delta\phi = 0^\circ$). So, it looks likely that as Nature was evolving the C-PC structure, the process of optimizing it for a better energy migration in PBS thus began.

Important, that in the case of a four-hexamer rod and $\beta 84$ -trap we have calculated the average excitation lifetime equal to $\tau_{tr}^{(4)} \cong 126$ ps. This value agrees well with the experimental data obtained by Suter et al. (1984), who have reported that in the case of C-PC rods consisting of 3–4 hexamers, the time of energy migration along the rods to the allophycocyanin is equal to 120–130 ps. We have also calculated the main time intervals of energy migration along the rod ensembles consisting of one, two, and three hexamers:

¹ Our preliminary evaluation has shown that the change of the trapping efficiency of the $\beta 84$ -terminal chromophores from 100% down to 50% has brought up $\leq 6\%$ decrease of the averaged exciton lifetime (τ_{tr}) in the C-PC.

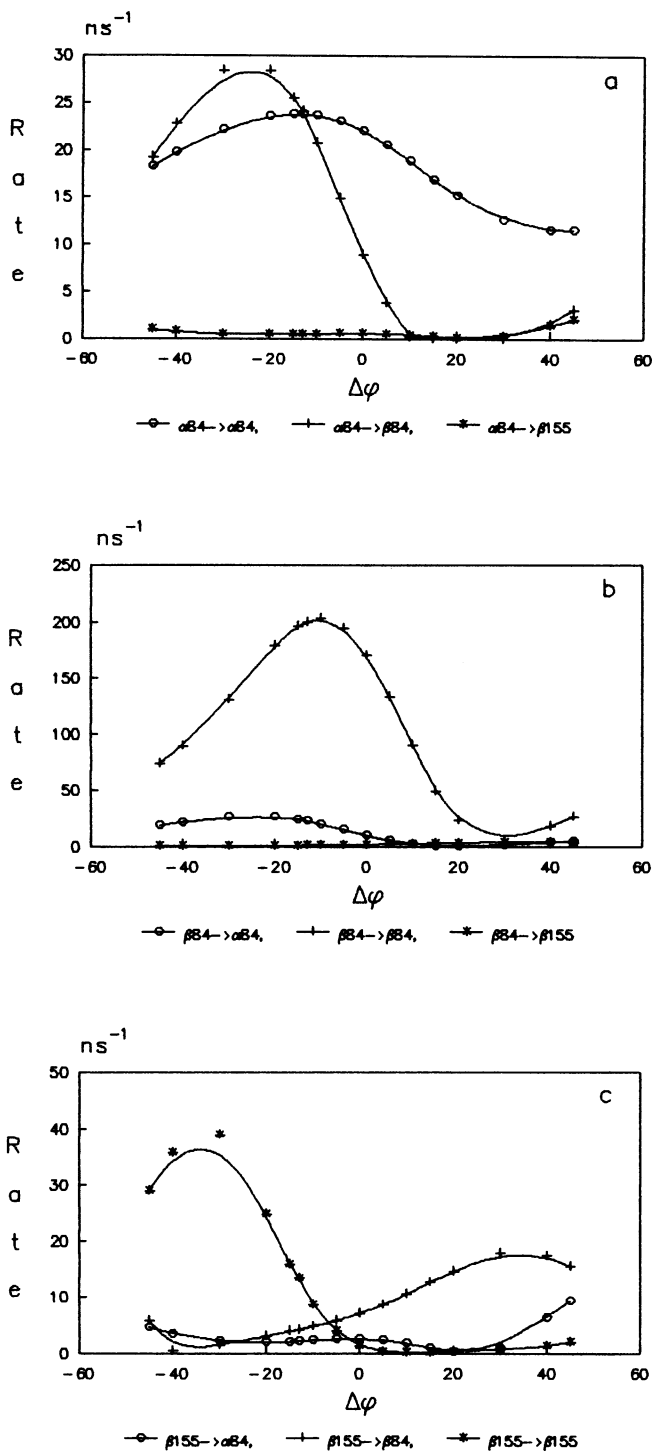

FIGURE 5 Graphs of energy migration rates between chromophores of trimer '2' of hexamer 'I' and trimer '1' of hexamer 'II' (see Fig. 1) versus the screw angle $\Delta\phi$ (around Z-axis) of the upper and lower trimers ('1' and '2') one relative to the other inside both hexamers in case of real orientation of chromophores; (a) transfer from $\alpha 84$, (b) transfer from $\beta 84$, (c) transfer from $\beta 155$.

$$\tau_{tr}^{(1)} : \tau_{tr}^{(2)} : \tau_{tr}^{(3)} \cong 7.6 : 29 : 70 \text{ ps.}$$

Another series of our modeling experiments was devoted to energy migration from the $\beta 155$ to the $\alpha 84$ and

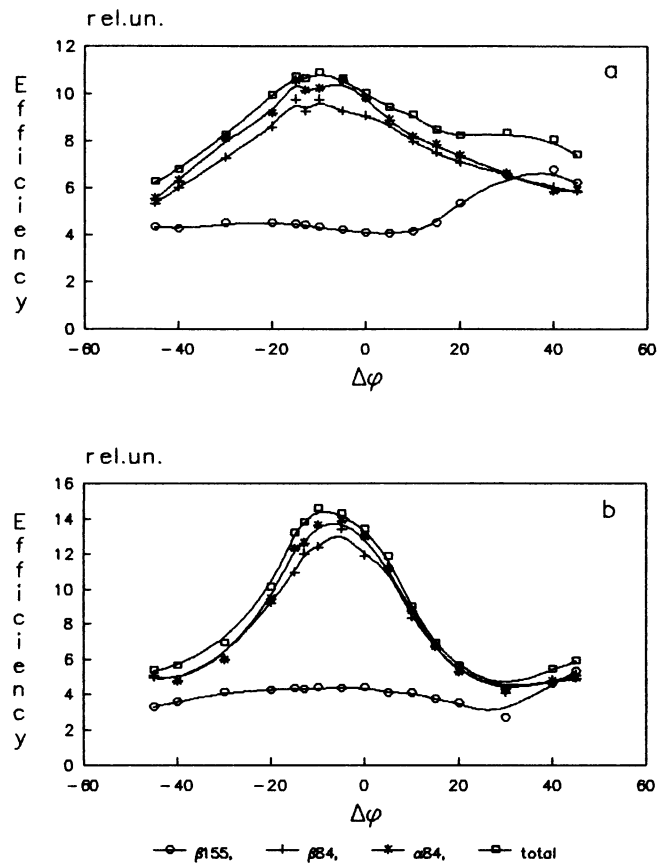

FIGURE 6 Graphs of the energy migration efficiency $\eta = \tau/\tau_{tr}$ ($\tau = 1.5$ ns) through the C-phycoyanin rod (consisting of four hexamers) versus the screw angle $\Delta\phi$ between '1' and '2' trimers (see Fig. 1); (a) random and (b) real orientation of chromophores; (OOO)— $\beta 155$ terminal chromophores are traps, (+++)— $\beta 84$ terminal chromophores are traps, (***)— $\alpha 84$ terminal chromophores are traps, (□□□)—all terminal chromophores ($\alpha 84$, $\beta 84$, and $\beta 155$) are traps, see the text; lines are the computer spline approximations (Harvard Graphics).

$\beta 84$ chromophores. We analyzed this process using the Monte-Carlo method in the cases of monomer, trimer, and hexamer. In these investigations only $\beta 155$ chromophores were initially excited.

Our calculations have revealed a fast increase of $\alpha 84$ and $\beta 84$ fluorescence and consequent decrease of $\beta 155$ fluorescence (Fig. 7), with the lifetimes equal to (for trimer and hexamer):

$$\tau_i : \tau_h = 35 : 11 \text{ ps,}$$

which reasonably agrees with the published data (see Introduction) and the rates of energy flow from $\beta 155$ to $\alpha 84$ and $\beta 84$ chromophores (see Table 1, trimer and hexamer cases):

$$K_i^{-1} : K_h^{-1} \cong 25 : 8 \text{ ps.}$$

The latter is the upper limit value for excitation leaving from the $\beta 155$ chromophores. The case of a monomer deserves a special analysis.

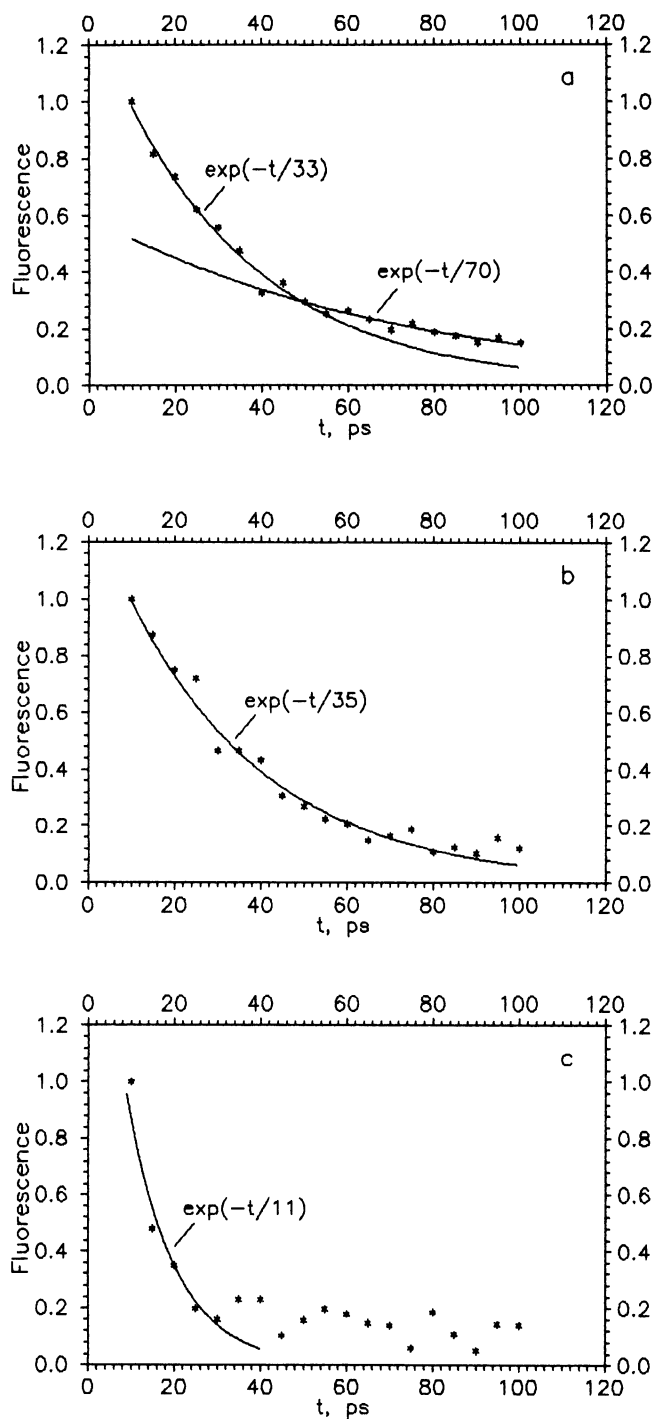

FIGURE 7 Kinetics of fluorescence decay in $\beta 155$ chromophores; (a) monomer case (averaged $\tau_m \sim 48$ ps), (b) trimer case ($\tau_t \sim 35$ ps), (c) hexamer case ($\tau_h \sim 11$ ps). The excitation conditions and analysis are presented in the text.

The data of Table 1 (monomer case) show that energy withdrawal from the $\beta 155$ chromophores proceeds in about 28 ps, i.e., $\tau_m \cong \tau_t$. Our calculations have shown (see Fig. 7 a) that $\beta 155$ fluorescence decay is two-exponential with the shorter lifetime about 33 ps (close to K_m^{-1})

and another one about 70 ps, which reflects relaxation processes of excitation distribution among monomer chromophores. In monomers, the relaxation kinetics is much slower than that in the trimer (see Table 1, monomer and trimer cases). If one tries to approximate this decay by one-exponential function the average value $\tau_m \cong 48$ ps would be obtained. This value agrees well with the experimental data available. In fact, it is nonrealistic to resolve in experiments two exponentials with the lifetimes differing only 2–3 times if the signal/noise ratio is not excellent and the response function of the instrument used is not considerably shorter than 30–100 ps, which was the case in many of the above referenced works. Besides, one should bear in mind that C-PC isolation may cause some conformational changes. These conformations may easily change the energy migration pattern as compared to the *in vivo* one.

A small ($\leq 10\%$) difference between the values of energy migration rates in our calculations and those by Sauer et al. (1987, 1988) may be also explained by the accuracy of determination of chromophore positions and orientations leading to errors in the chromophore-to-chromophore distances R_{ij} and orientation factors.

Also important is the fact that in the modern literature the values of radiative lifetimes τ_0 (see Eq. 1) and Förster radius of interchromophore excitation migration $R_0^{(11)}$ (see Eq. 5) are not yet known for sure. Particularly, in the works by Dale and Teale (1970), Grabowski and Gantt (1980), Sandström et al. (1988), Gantt (1980), Sauer et al. (1987), Wong et al. (1981), Sineshchekov et al. (1984) the C-PC Förster radius varied in the range from 50 to 72 Å. It is one of the major results of our work that our C-PC theoretical calculations may fit available experimental data only for Förster radius $R_0 = 70\text{--}75$ Å, which represents the upper limit from the above mentioned set of its theoretical calculations. Therefore, we come to the conclusions that in the course of evolution Nature expended considerable effort to achieve higher R_0 , advantageous mutual orientations of chromophores, etc., in order to provide greater efficiency of excitation delivery along PBS to chlorophylls.

And one more general remark: We believe that phyco-biliproteins are unique objects for investigations of some fundamental physical problems of energy migration between molecules. One of these problems is applicability of Förster theory for objects like C-PC (R^{-6} dependence). All our calculations were based on this theory, which was experimentally corroborated by the contribution of Strayer and Haugland (1967), and we got a good matching of our results with the data of other authors.

In fact, the use of averaged intermolecular distances in concentrated solid and liquid solutions is strongly criticized because of the probable appearance of aggregates, and the use of averaged orientation factor $2/3$ for such systems is also problematical, because in some real molecular interactions their mutual orientations may not be

random. Now, in some phycobiliproteins both these parameters are known with good accuracy and it is a good challenge to computer methods to solve the inverse problem of estimation of the fundamental Förster parameter [−6] in *R* degree.

Received for publication 2 January 1992 and in final form 10 September 1992.

REFERENCES

1. Agranovich, V. M., N. A. Efremov, and V. V. Kirsanov. 1980. Computer simulation of kinetics of excitation bimolecular quenching by Monte-Carlo method. *Fiz. Tverd. T. (USSR)* 22:2118–2127.
2. Berns, D. S., and R. MacColl. 1989. Phycocyanin in physical-chemical studies. *Chem. Rev.* 89:807–825.
3. Cohen-Bazire, G., and D. A. Bryant. 1982. Phycobilisomes: composition and structure. In *The biology of cyanobacteria*. Vol. 19. N. G. Carr and B. Whitton, Plenum Press, London, Boston. 143–189.
4. Dale, R. E., and F. W. J. Teale. 1970. Number and distribution of chromophore types in native phycobiliproteins. *Photochem. Photobiol.* 12:99–117.
5. Demidov, A. A. 1987. Application of the Monte Carlo method for investigating energy migration in complex organic compounds. *Moscow University Physics Bulletin* (English translation from *Vestnik Moskovskogo Universiteta. Fizika*, 1987, 28:63–68), Allerton Press, Inc., 42:74–80.
6. Demidov, A. A. 1988a. A Monte Carlo study of energy-transfer time dependence in organic complexes. *Moscow University Physics Bulletin* (English translation from *Vestnik Moskovskogo Universiteta. Fizika*, 1988, 29:38–42), Allerton Press, Inc., 43:38–41.
7. Demidov, A. A. 1988b. Simulating nonlinear optical processes in organic complexes. *Moscow University Physics Bulletin* (English translation from *Vestnik Moskovskogo Universiteta. Fizika*, 1988, 29:56–61), Allerton Press, Inc., 43:61–65.
8. Demidov, A. A. 1989. Numerical analysis of the connection between the singlet-singlet annihilation pair and the spatial structure of a complex of a limited number of molecules. *Journal of Applied Spectroscopy* (English translation from *Zhurnal Prikladnoi Spektroskopii*, 1989, 50:103–106), Plenum Publishing Corp., 50:87–89.
9. Fisher, R. G., N. E. Woods, H. E. Fuchs, and R. M. Sweet. 1980. Three-dimensional structures of C-phycocyanin and B-phycoerythrin at 5-Å resolution. *J. Biol. Chem.* 255:5082–5089.
10. Förster, Th. 1948. Zwischenmolekulare Energiewanderung und Fluoreszenz. *Ann. Physik* 6:55–75.
11. Gantt, E. 1980. Structure and function of phycobilisomes: light harvesting pigment complexes in red and blue-green algae. *Int. Rev. Cytol.* 66:45–80.
12. Gantt, E. 1981. Phycobilisomes. In *Annu. Rev. Plant Physiol.* 32:327–347.
13. Glazer, A. N., S. Fang, and D. M. Brown. 1973. Spectroscopic properties of C-phycocyanin and its α and β subunits. *J. Biol. Chem.* 248:5679–5685.
14. Glazer, A. N. 1984. Phycobilisome. A macromolecular complex optimized for light energy transfer. *Biochim. Biophys. Acta.* 768:29–51.
15. Grabowski, J., and E. Gantt. 1978. Photophysical properties of phycobiliproteins from phycobilisomes: fluorescence lifetimes, quantum yields, and polarization spectra. *Photochem. Photobiol.* 28:39–45.
16. Hackert, M. L., C. Abad-Zapatero, S. E. Stevens, Jr., and J. L. Fox. 1977. Crystallization of C-phycocyanin from the marine blue-green algae *Agmenellum quadruplicatum*. *J. Mol. Biol.* 111:365–369.
17. Hanzlik, C. A., L. E. Hancock, R. S. Knox, D. Guard-Friar, and R. MacColl. 1985. Picosecond fluorescence spectroscopy of the biliprotein phycocyanin 612: direct evidence for fast energy transfer. *J. Luminescence* 34:99–106.
18. Heffeler, P., W. John, H. Scheer, and S. Schneider. 1984a. Thermal denaturation of monomeric and trimeric phycocyanins studied by static and polarized time-resolved fluorescence spectroscopy. *Photochem. Photobiol.* 39:221–232.
19. Heffeler, P., P. Geiselhart, T. Mindl, and S. Schneider. 1984b. Time-resolved polarized fluorescence of C-phycocyanin and its subunits from *Mastigocladus laminosus*. *Z. Naturforsch.* 39c:606–616.
20. Holzwarth, A. R., J. Wendler, and W. Wehrmeyer. 1983. Studies on chromophore coupling in isolated phycobiliproteins. I. Picosecond fluorescence kinetics of energy transfer in phycocyanin 645 from *Chroomonas Sp.* *Biochim. Biophys. Acta.* 724:388–395.
21. Holzwarth, A. R. 1986. Fluorescence lifetimes in photosynthetic systems. *Photochem. Photobiol.* 43:707–725.
22. Holzwarth, A. R. 1987. Picosecond fluorescence spectroscopy and energy transfer in photosynthetic antenna pigments. In *The Light Reactions*. J. Barber, editor. Elsevier, Amsterdam. 95–157.
23. Holzwarth, A. R., J. Wendler, and G. W. Suter. 1987. Studies on chromophore coupling in isolated phycobiliproteins. II. Picosecond energy transfer kinetics and time-resolved fluorescence spectra of C-phycocyanin from *Synechococcus 6301* as a function of the aggregation state. *Biophys. J.* 51:1–12.
24. Kobayashi, T., E. O. Degenkolb, R. Bersohn, P. M. Rentzepis, R. MacColl, and D. S. Berns. 1979. Energy transfer among the chromophores in phycocyanins measured by picosecond kinetics. *Biochemistry.* 18:5073–5078.
25. Köhler, W., J. Friedrich, R. Fischer, and H. Scheer. 1988. High resolution frequency selective photochemistry of phycobilisomes at cryogenic temperatures. *J. Chem. Phys.* 89:871–874.
26. MacColl, R., and D. Guard-Friar. 1987. Phycobiliproteins. CRC Press, Boca Raton, FL. 218 pp.
27. Malak, H., and R. MacColl. 1991. Picosecond fluorescence from phycocyanin 612. *Photochem. Photobiol.* 53:367–370.
28. Mimuro, M., P. Füglistaller, R. Rübli, and H. Zuber. 1986. Functional assignment of chromophores and energy transfer in C-phycocyanin isolated from the thermophilic cyanobacterium *Mastigocladus laminosus*. *Biochim. Biophys. Acta.* 848:155–166.
29. Mörschel, E., K.-P. Koller, and W. Wehrmeyer. 1980. Biliprotein assembly in the disc-shaped phycobilisomes of *Phodella violacea* electron microscopical and biochemical analysis of C-phycocyanin and allophycocyanin aggregates. *Arch. Microbiol.* 125:43–51.
30. Pellegrino, F., D. Wong, R. R. Alfano, and B. A. Zilinskas. 1981. Fluorescence relaxation kinetics and quantum yield from the phycobilisomes of the blue-green algae *Nostoc sp.* measured as a function of single picosecond pulse intensity. *Photochem. Photobiol.* 34:691–696.
31. Porter, G., C. J. Tredwell, G. F. W. Searle, and J. Barber. 1978.

- Picosecond time-resolved energy transfer in *Porphyridium cruentum*. *Biochim. Biophys. Acta.* 501:232–245.
32. Sandström, A., T. Gillbro, V. Sundström, R. Fischer, and H. Scheer. 1988. Picosecond time-resolved energy transfer within C-phycoyanin aggregates of *Mastigocladus laminosus*. *Biochim. Biophys. Acta.* 933:42–53.
 33. Sauer, K., H. Scheer, and P. Sauer. 1987. Förster transfer calculations based on crystal structure data from *Agmenellum quadruplicatum* C-phycoyanin. *Photochem. Photobiol.* 46:427–440.
 34. Sauer, K., and H. Scheer. 1988. Excitation transfer in C-phycoyanin Förster transfer rate and exciton calculation based on new crystal structure form *Agmenellum quadrupl.* *Biochim. Biophys. Acta.* 936:157–170.
 35. Scheer, H. 1981. Biliproteine. *Angew. Chem. Int. Ed. Engl.* 93:230–250.
 36. Schirmer, T., W. Bode, R. Huber, W. Sidler, and H. Zuber. 1985. X-ray crystallographic structure of the light harvesting biliprotein C-phycoyanin from the thermophilic cyanobacterium *Mastigocladus laminosus* and its resemblance to globin structures. *J. Mol. Biol.* 184:257–277.
 37. Schirmer, T., W. Bode, and R. Huber. 1987. Refined three-dimensional structures of two cyanobacterial C-phycoyanins at 2.1 and 2.5 Å resolution. A common principle of phycobilin–protein interaction. *J. Mol. Biol.* 196:677–695.
 38. Schneider, S., P. Geiselhart, S. Siebzehnriibl, R. Fischer, and H. Scheer. 1988. Energy transfer within PC trimers of *Mastigocladus laminosus* studied by picosecond time-resolved transient absorption spectroscopy. *Z. Naturforsch.* 43c:55–62.
 39. Sherstnev, K. B. 1972. Use of statistical method for solution of the problem of excitation energy transfer among admixture centers in crystals. *Opt. Spektro. (USSR).* 33:292–299.
 40. Siebzehnriibl, S., R. Fischer, and H. Scheer. 1987. Chromophore assignment in C-phycoyanin from *Mastigocladus laminosus*. *Z. Naturforsch.* 42c:258–262.
 41. Sineshchekov, V. A., I. A. Muslimov, and O. D. Bekasova. 1984. Excitation energy migration in phycobilisomes. *Molec. Biolog. (USSR).* 18:447–456.
 42. Strayer, L., and R. P. Haugland. 1967. Energy transfer: a spectroscopic ruler. *Proc. Natl. Acad. Sci. USA.* 58:719–726.
 43. Suter, G. W., P. Mazzola, J. Wendler, and A. R. Holzwarth. 1984. Fluorescence decay kinetics in phycobilisomes isolated from the blue-green algae *Synechococcus 6301*. *Biochim. Biophys. Acta.* 766:269–276.
 44. Zilinskas, B. A., and L. S. Greenwald. 1986. Phycobilisome structure and function. *Photosynth. Res.* 10:7–35.
 45. Zuber, H. 1987. The structure of light-harvesting pigment-protein complexes. In *Light Reactions*. J. Barber, editor. Elsevier Science Publishers, Amsterdam. 197–259.
 46. Wendler, J., W. John, H. Scheer, and A. R. Holzwarth. 1986. Energy transfer in trimeric C-phycoyanin studied by picosecond fluorescence kinetics. *Photochem. Photobiol.* 44:79–85.
 47. Wong, D., F. Pellegrino, R. R. Alfano, and B. A. Zilinskas. 1981. Fluorescence relaxation kinetics and quantum yield from the isolated phycobiliproteins of the blue-green alga *Nostoc Sp.* measured as a function of single picosecond pulse intensity I. *Photochem. Photobiol.* 33:651–662.