

## The Synthesis of Amino Acids by *Methanobacterium omelianskii*

By M. KNIGHT,\* R. S. WOLFE† AND S. R. ELSDEN\*

Department of Microbiology and Agricultural Research Council Unit for Microbiology,  
University of Sheffield

(Received 12 October 1965)

1. *Methanobacterium omelianskii* was grown on  $^{14}\text{C}$ CO<sub>2</sub> and unlabelled ethanol, or on [1- $^{14}\text{C}$ ]- or [2- $^{14}\text{C}$ ]-ethanol and unlabelled carbon dioxide. The cell protein was hydrolysed and certain of the amino acids were isolated and degraded. 2. Carbon from both carbon dioxide and ethanol is used for biosynthesis of amino acids, and in most cases ethanol is incorporated as a C<sub>2</sub> unit. Ethanol carbon atoms and carbon dioxide carbon atoms apparently enter the same range of compounds. Ethanol and carbon dioxide are equally important as sources of cell carbon. 3. The origins of carbon atoms of aspartate, alanine, glycine, serine and threonine are consistent with the synthesis of these amino acids, by pathways known to exist in aerobic organisms, from pyruvate arising by a C<sub>2</sub>+C<sub>1</sub> condensation. The proportion of total radioactivity found in C-1 of lysine, proline, methionine and valine is consistent with synthesis of these amino acids by pathways similar to those found in *Escherichia coli*. Isoleucine is probably formed by carboxylation of a C<sub>5</sub> precursor formed entirely from ethanol. Glutamate is formed by an unknown pathway.

*Methanobacterium omelianskii* is an obligate anaerobe, capable of growing with a primary or secondary alcohol and carbon dioxide as its sole source of carbon and energy. The oxidation of the alcohol is coupled with the reduction of carbon dioxide to methane, according to the equations below. Ethanol is the substrate which is utilized best.

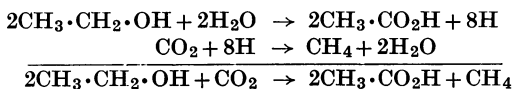

Although the organism is capable of reducing carbon dioxide to methane under a hydrogen atmosphere, there is no evidence that it can grow under these conditions (Schnellen, 1947).

It has become apparent recently that the pathways of biosynthesis of obligate anaerobes are not necessarily the same as those found in *Escherichia coli*, *Neurospora* and yeast. The labelling patterns of amino acids isolated from *Rhodospirillum rubrum* grown on labelled acetate or labelled carbon dioxide (Cutinelli, Ehrensward, Reio, Saluste & Stjernholm,

1951a; Cutinelli *et al.* 1951b; Hoare, 1963), from *Clostridium kluyveri* grown on acetate or ethanol (Tomlinson, 1954a,b) and from *Ruminococcus flavefaciens* (Allison, Bryant & Doetsch, 1962; Allison & Bryant, 1963) show that in these organisms the biosynthetic pathways do differ from those found in aerobic organisms.

The relative importance of ethanol and carbon dioxide as sources of carbon for biosynthesis in *M. omelianskii* has never been examined. The work to be described was undertaken to determine whether ethanol carbon atoms are used for biosynthesis in *M. omelianskii*, and whether the biosynthetic pathways are similar to those in other anaerobes.

### MATERIALS AND METHODS

*Maintenance of micro-organisms.* The culture of *M. omelianskii* used was obtained from Dr H. A. Barker. It was maintained on the semi-solid ethanol-bicarbonate medium of Johns & Barker (1960), and was transferred every 2-3 weeks.

*Nocardia globerula* (N.C.I.B. no. 8852) was maintained and grown, and an acetone-dried powder prepared, as described by Crawford (1958).

*Radioactive compounds.* The Na<sub>2</sub><sup>14</sup>C<sub>3</sub>, [1-<sup>14</sup>C]ethanol and [2-<sup>14</sup>C]ethanol were obtained from The Radiochemical Centre, Amersham, Bucks., and were used without further purification.

\* Present address: Agricultural Research Council Food Research Institute, Earham Laboratory, Recreation Road, Norwich, NOR.26G.

† Present address: Department of Microbiology, University of Illinois, Urbana, Illinois, U.S.A.

*Estimation of radioactivity.* Barium carbonate plates were prepared and counted in a Packard gas-flow counter as described by Knight (1962), except that the gas used was methane, supplied by Middlesex County Council Main Drainage Works, Isleworth, Middlesex. It was purified before use by successive passage over soda lime and magnesium perchlorate.

Radioactive material in column chromatography eluates was detected by plating 0.5 ml. portions of each sample on aluminium planchets, and counting them in the same counter. Although there was a substantial weight of NaCl on each planchet, it was assumed that the same weight was present on each, and the observed activities were not corrected for self-absorption. Since this method was used more for detection than for measurement, the errors introduced by this assumption are unimportant.

*Paper chromatography and electrophoresis.* Descending paper chromatography was carried out at 22°. The following single-phase solvents were used: 1, acetone–butan-1-ol–water–diethylamine (10:10:5:2, by vol.) (Hardy, Holland & Naylor, 1955); 2, butan-2-ol–formic acid–water (15:3:2, by vol.) (Hausmann, 1952); 3, propan-1-ol–water (4:1, v/v) (Kemble & Macpherson, 1954); 4, butan-1-ol–propionic acid–water (Benson *et al.* 1950); 5, phenol–water (Bassham & Calvin, 1957); 6, butan-1-ol–ethyl methyl ketone–water (2:2:1, by vol.) (Hardy *et al.* 1955); 7, 2-methylpropan-1-ol–ethyl methyl ketone–water (7:5:3, by vol.) (Kemble & Macpherson, 1954); 8, propan-1-ol–ethyl methyl ketone–diethylamine (10:10:5:2, by vol.) (Hardy *et al.* 1955).

The apparatus used for paper electrophoresis was based on the design of Ingram & Stretton (1962). The buffers and conditions used were: buffer 1, 33 mm-ammonium acetate, pH 6.0 (Hoare, 1963) for 90 min. at 1000 v; buffer 2, pyridine–acetic acid–water, pH 6.5 (10:0.4:90, by vol.) (Ryle, Sanger, Smith & Kitai, 1955) for 90 min. at 1800 v; buffer 3, pyridine–formic acid–water, pH 2.2 (0.3:4:96, by vol.) (Richmond & Hartley, 1959) for 90–120 min. at 1800 v.

Whatman no. 1 paper was used throughout, except that Whatman no. 3MM paper was used in the preliminary separation of material from Expt. B (see below). Radioautographs were prepared as described by Knight (1962). Compounds were eluted from paper as described by Knight (1962).

#### *Growth experiments with radioactive substrates*

*Medium and cultural conditions.* The medium was prepared as follows: 0.5 g. of  $(\text{NH}_4)_2\text{SO}_4$ , 1 ml. of vitamin solution (Wolin, Wolin & Wolfe, 1963) and 1 ml. of mineral solution (Wolin *et al.* 1963) in 400 ml. of water in a 500 ml. Florence flask were autoclaved for 15 min. at 15 lb/in.<sup>2</sup>. When cool, the following additions were made aseptically: (a) 3 g. of  $\text{K}_2\text{HPO}_4$  + 4.5 g. of  $\text{KH}_2\text{PO}_4$  in 50 ml. of water; (b) 30 ml. of 5% (w/v)  $\text{Na}_2\text{CO}_3$ ; (c) 10 ml. of fresh 1%  $\text{Na}_2\text{S}_9\text{H}_2\text{O}$ ; (d) 3 ml. of ethanol. The ethanol was sterilized by filtration; the other solutions were autoclaved. The medium was inoculated at once with 20 ml. of an actively growing culture growing on the semi-solid maintenance medium. A 1 cm.-deep layer of molten petroleum jelly–paraffin wax (1:1) was poured on top of the medium, the space above was filled with  $\text{N}_2$  and the flask closed with a rubber bung. The culture was incubated at 37°.

After about 16–24 hr., when the culture was evolving gas vigorously, 1 mc (200  $\mu\text{moles}$ ) of  $\text{Na}_2^{14}\text{CO}_3$  (Expt. B) or

100  $\mu\text{C}$  (50  $\mu\text{moles}$ ) of  $[1\text{-}^{14}\text{C}]$ - or  $[2\text{-}^{14}\text{C}]$ -ethanol (Expts. C and M) in 3 ml. of water was injected into the culture.

About 3 days after inoculation, when gas production ceased, the bacteria were harvested by centrifugation and washed twice with water.

*Fractionation of bacteria.* The washed cell pellet was resuspended in 95% (v/v) ethanol and centrifuged again. The supernatant was discarded. The residue was suspended in 2.5 ml. of 5% (w/v) trichloroacetic acid and heated for 6 min. at 90°. After cooling the residue was centrifuged again. The pellet was suspended in 10 ml. of 5% (w/v) HCl, and hydrolysed by refluxing for 12 hr. The hydrolysate was evaporated to dryness by heating on a boiling-water bath in a current of air. The last traces of HCl were removed by dissolving the dried hydrolysate in water and evaporating to dryness once more.

*Preliminary separation of amino acids.* The amino acids of the hydrolysate were first separated into acidic, neutral and basic fractions by electrophoresis in buffer 1. The three fractions were detected by radioautography, eluted from the paper and separated further as follows.

The acidic amino acids, aspartate and glutamate, were separated by chromatography in solvent 2.

The neutral amino acids were further fractionated by chromatography in solvent 3. Serine was separated from glycine and alanine from threonine by electrophoresis in buffer 3. Valine and methionine were separated by chromatography in solvent 6, leucine and isoleucine in solvent 7, and proline was separated from tyrosine by chromatography in solvent 8.

The basic amino acids were separated by chromatography in solvent 1.

*Identification and purification of amino acids.* The tentative identifications of amino acids based on their behaviour during the primary and secondary separations were confirmed in one of two ways. Those compounds which were degraded (aspartate and alanine from all three experiments, glycine from Expts. B and C, and glutamate, serine and threonine from Expt. B) were each purified further by chromatography or electrophoresis in two different systems, with markers run in parallel, before degradation. The solvent and buffer systems used are shown in Table 1.

The identity of certain amino acids was confirmed by co-chromatography with carrier amino acid on Dowex 50 (cation-exchange resin AG 50 W X12, 200–400 mesh; Bio-Rad Laboratories, Richmond, Calif., U.S.A.; supplied by Calbiochem A.-G., Lucerne, Switzerland) in HCl as described by Wall (1953), except that a single concentration of HCl known to elute the amino acid under consideration was used. Fractions (2–4 ml.) were collected, the HCl was neutralized by addition of NaOH and the amino acid content of each fraction determined by the ninhydrin method of Yemm & Cocking (1955). Samples were plated on aluminium planchets and counted as described above.

#### *Degradation of labelled amino acids*

In general, the procedure followed in the degradation of amino acids was to estimate the specific activity of the compound after the addition of carrier. Successive carbon atoms were converted into  $\text{CO}_2$  and their specific activity was measured. Each intermediate in a degradation sequence was isolated and purified. Specific activities were estimated

Table 1. Purification of amino acids

Amino acid	First stage	Second stage
Aspartate	Electrophoresis, buffer 2	Two-dimensional chromatography, solvents 5 and 4
Glutamate	Electrophoresis, buffer 2	Two-dimensional chromatography, solvents 5 and 4
Alanine	Electrophoresis, buffer 3	Chromatography, solvents 1 and 4
Glycine	Electrophoresis, buffer 3	Chromatography, solvent 1
Serine	Electrophoresis, buffer 3	Chromatography, solvent 1 or 4
Threonine	Electrophoresis, buffer 3	Chromatography, solvent 1

so that the losses inherent in an extended sequence of manipulations could be neglected. More than 90% of the total specific activity of the complete molecule could usually be accounted for.

*General procedures.* Combustion of organic compounds was carried out by the procedure of Sakami (1955) as modified by Knight (1962). Carbon dioxide, collected by trapping in 1 N-NaOH, was estimated by acidification of samples in Warburg manometers. Amino acids were estimated by decarboxylation with chloramine-T (Kemble & Macpherson, 1954) in Warburg manometers. The manometer vessels used were those described by Knight (1962), from which the CO<sub>2</sub> produced could be collected. In some cases the CO<sub>2</sub> was plated as BaCO<sub>3</sub> and counted to provide an independent check on the radioactivity of C-1.

*Degradation of alanine.* Alanine was decarboxylated, the acetaldehyde was oxidized and the acetate was recovered and purified as described by Hoare & Gibson (1964). The specific activity of the recovered acetate (C-2 and C-3) was estimated by steam-distillation of a sample from a Markham (1942) still and by combustion of a second sample. The remainder of the acetate was decarboxylated by treatment with azide by the procedure of Sakami (1955) with the modifications introduced for the degradation of propionate by Knight (1962).

*Degradation of aspartate.* Aspartate from Expt. B was degraded by treatment with chloramine-T under the conditions described by Kemble & Macpherson (1954). Under these conditions, both C-1 and C-4 are liberated as CO<sub>2</sub> (Cohen, 1940).

Aspartate from Expts. C and M was degraded as far as alanine by the procedure described by Knight (1962). The alanine was then purified by electrophoresis in buffer 3, and was degraded by the procedure described above. In this case, since the first stage of the degradation was carried out in a manometer, it was necessary to make a second addition of carrier alanine and re-determine specific activity before the next stage of degradation. The activity of the carbon atoms removed subsequently was referred to this second specific activity.

*Degradation of glycine.* The radioactivity of glycine C-1 was determined after decarboxylation with chloramine-T. That of glycine C-2 was determined as follows. Glycine (200 μmoles) in 1–2 ml. of water + 2 ml. of saturated KH<sub>4</sub>PO<sub>4</sub> was treated with ninhydrin (250 mg. in 7.0 ml. of water) in the still described by Elsdén & Gibson (1954) for the estimation of lactate. The ninhydrin solution was added dropwise from the funnel while steam was passed through the glycine solution. Distillate (200 ml.) was collected at a rate of 8–13 ml./min. The recovery of formaldehyde, estimated iodometrically, from a standard glycine solution, was 70–75%. The formaldehyde was oxidized for formate and the formate oxidized to CO<sub>2</sub> as described by Sakami (1955).

*Degradation of serine.* Serine was degraded by treatment with periodate, by a modification of the method of Sakami (1955).

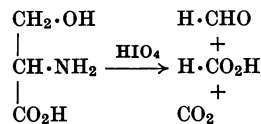

After decarboxylation with periodate and collection of C-1 as CO<sub>2</sub>, iodate and periodate were precipitated from the reaction mixture by cooling to 0° and adding 5 ml. of ice-cold 1 M-BaCl<sub>2</sub> + 5 ml. of ice-cold 1 N-KOH. After 10 min. at 0° the precipitate was filtered off and washed three times with ice-cold water. Filtrate and washings were combined, and after the pH had been adjusted to 3 with acetic acid, were treated with HgCl<sub>2</sub> in acetate buffer, to oxidize the formate, as described by Sakami (1955). The formaldehyde, which is not oxidized under these conditions, was recovered by steam-distillation, and was then oxidized to formate, and the formate purified and oxidized to CO<sub>2</sub> by the procedure of Sakami (1955).

*Degradation of threonine.* Threonine was degraded by treatment with periodate, as first suggested by Aronoff (1956).

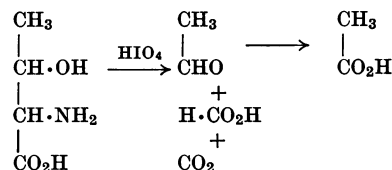

The apparatus used is shown in Fig. 1. All joints were lubricated with silicone grease, except for the main joint, for which a polytetrafluoroethylene (PTFE) liner (Fisons Scientific Apparatus Ltd, Loughborough, Leics.) was used. The apparatus was set up as shown in Fig. 1, and pressure was reduced to about 350 mm. Hg. The periodate was then admitted and the apparatus was left overnight at room temperature. CO<sub>2</sub> was recovered by attaching a CO<sub>2</sub> collector to the outlet tap and drawing a current of CO<sub>2</sub>-free air through the apparatus for 60 min. Formate was purified and oxidized as described in the degradation of serine. Acetate was recovered from the contents of the centre well and was purified and degraded as described in the degradation of alanine. Recoveries obtained with a standard threonine solution were: CO<sub>2</sub>, 98–101%; formate (as CO<sub>2</sub> after purification and oxidation), 40–45%; acetate (recovered from chromic acid mixture), 50–60%.

*Partial degradation of glutamate.* Glutamate was decarboxylated at C-1 by treatment with chloramine-T by using the macro-scale procedure of Hoare (1963). The succinate

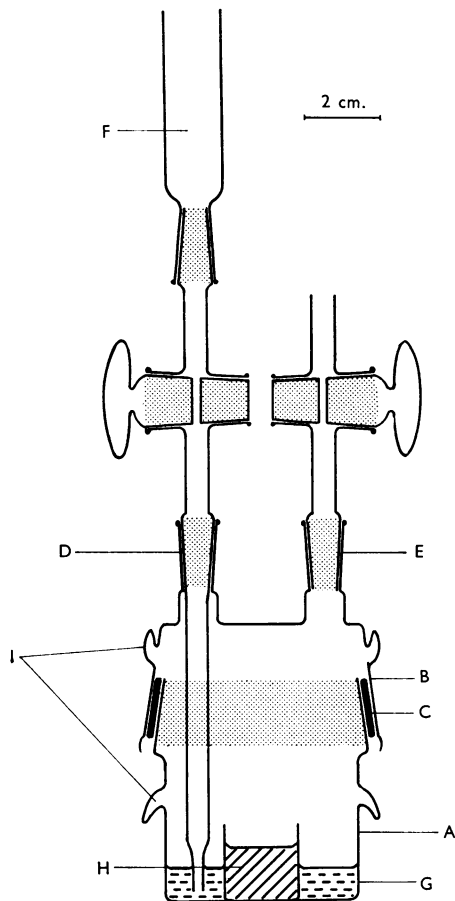

Fig. 1. Apparatus used for periodate oxidation of threonine. A: main vessel, made from B50 standard cone. B: lid, made from B50 standard socket. C: PTFE liner for joint. D: inlet port. E: outlet port. F: detachable funnel, containing 3 ml. of 0.5M-periodate. G: 1 ml. of 400–500 mM-threonine + 5 ml. of 0.5M-KH<sub>2</sub>PO<sub>4</sub>-KOH buffer, pH 5.8. H: 2 ml. of 5M-CrO<sub>3</sub> in 25% (v/v) H<sub>2</sub>SO<sub>4</sub>. I: lugs for springs.

formed was recovered, purified by chromatography on Celite as described by Knight (1962), and subjected to combustion to CO<sub>2</sub>.

Glutamate was decarboxylated at C-5 by treatment with azide (Cutinelli *et al.* 1951a). When the reaction was complete, the acid reaction mixture was diluted, neutralized and evaporated to dryness. The product of decarboxylation (presumed to be 2,4-diaminobutyrate) was subjected to combustion to CO<sub>2</sub>.

**Partial degradation of lysine, proline, isoleucine, valine and methionine.** Lysine, proline, isoleucine, valine and methionine from Expt. B were partially degraded by treatment with chloramine-T under the conditions used for the decarboxylation of glutamate. Only the CO<sub>2</sub> from C-1 was collected; no attempt was made to recover the remainder of the carbon chain.

The solutions of amino acid used were recovered from column chromatography and contained so much NaCl (800–1000 equiv. of Cl<sup>-</sup>/mole of amino acid) that it was not possible to subject the acids to combustion to determine specific activity unless the solution was first partially de-salted. This was done on a column of ion-retardation resin (AG 11A8; Bio-Rad Laboratories, U.S.A., supplied by Calbiochem, Lucerne, Switzerland) (Rollins, Jensen & Schwartz, 1962). Before use the resin (500g.) on a column was washed with 1N-HCl (1l.), 1N-NaOH (1l.), followed by distilled water until the effluent was neutral (about 50l.). The relatively large volumes of solution to be de-salted (40–45 ml.) demanded a large resin bed (32 cm. × 4.9 cm. diam.). With this column, at flow rates of 0.21–0.36 ml./cm<sup>2</sup>./min., recoveries of 70–75% of amino acid with at most 15–20% of the original amount of chloride were obtained. It was found that these amounts of salt did not interfere with the combustion procedure.

## RESULTS

**Amino acids identified.** The following radioactive amino acids were identified in the protein hydrolysate of *M. omelianskii* grown on radioactive substrates: aspartate, glutamate, alanine, serine and threonine (from all three experiments); glycine (from Expts. B and C only), and arginine, lysine, isoleucine, proline, valine and methionine (from Expt. B only). Glutamate, serine and threonine from Expts. C and M, and arginine, lysine, proline, isoleucine, valine and methionine from Expt. B were identified by co-chromatography with carrier amino acid on Dowex 50. The remaining amino acids were identified by paper-chromatographic procedures as a preliminary to degradation. In Expts. C and M, the radioactive ethanol was diluted by the large quantities of ethanol present as substrate, and since the bacteria assimilated only a small proportion of the substrate, the radioactivity in the amino acids was often so low as to make even identification impossible. Nevertheless, radioautographs of the separation of neutral amino acids from these experiments resemble those from Expt. B very closely, showing that ethanol carbon atoms enter the whole range of amino acids. The low level of radioactivity incorporated into these amino acids has usually made it impossible to degrade them.

**Complete degradation of alanine, aspartate, glycine, serine and threonine.** The results of the degradation of these amino acids are given in Tables 2–6.

The results of the degradation of alanine from all three experiments are given in Table 2. These show that C-1 of alanine is derived from carbon dioxide and that carbon dioxide makes almost no contribution to C-2 and C-3. Alanine C-2 is derived primarily from ethanol C-1 and C-3 primarily from ethanol C-2, though there is some evidence of mixing.

The results of the degradation of aspartate from Expt. B are given in Table 3. Almost all the activity

Table 2. *Degradation of alanine*

After determination of the initial specific activity and decarboxylation of a sample with chloramine-r, the remaining alanine was decarboxylated by treatment with ninhydrin. Acetate (C-2 and C-3 of alanine) was purified and decarboxylated by treatment with azide. Methylamine (C-3 of alanine) was recovered and oxidized to CO<sub>2</sub>.

Source of <sup>14</sup> C	Degradation stage	C of alanine recovered as CO <sub>2</sub>	CO <sub>2</sub> recovered (μmoles)	Total radioactivity (counts/min.)	Sp. activity (counts/min./μmole)	Rel. sp. activity	Recovery (%)
N <sub>2</sub> <sup>14</sup> CO <sub>2</sub> (Expt. B)	Combustion of alanine (initial sp. activity)	C-1, C-2 and C-3	129 (≡ 42.9 μmoles of alanine)	1100	25.6*	1.00	
	Decarboxylation of alanine (with chloramine-r)	C-1	18.3	443	24.2	0.95	
	Decarboxylation of alanine (with ninhydrin)	C-1	214	5180	24.2	0.95	
	Decarboxylation of acetate	C-2	112	30	0.3	0.01	
[1- <sup>14</sup> C]Ethanol (Expt. C)	Combustion of methylamine	C-3	59.4	63	1.1	0.04	100
	Combustion of alanine (initial sp. activity)	C-1, C-2 and C-3	300 (≡ 100 μmoles of alanine)	209	2.09*	1.00	
	Decarboxylation of alanine (with chloramine-r)	C-1	44.7	0	0	0	
	Decarboxylation of alanine (with ninhydrin)	C-1	154	0	0	0	
[2- <sup>14</sup> C]Ethanol (Expt. M)	Decarboxylation of acetate	C-2	86.2	169	1.95	0.93	
	Combustion of methylamine	C-3	86.2	20	0.23	0.11	104
	Combustion of alanine (initial sp. activity)	C-1, C-2 and C-3	265 (≡ 88.3 μmoles of alanine)	469	5.31	1.00	
		C-1, C-2 and C-3	133 (≡ 44.3 μmoles of alanine)	239	5.41	5.36*	
	Decarboxylation of alanine (with chloramine-r)	C-1	35.3	26	0.74	0.14	
	Decarboxylation of alanine (with ninhydrin)	C-1	99.5	40	0.40	0.07	
Combustion of methylamine	Decarboxylation of acetate	C-2	102	0	0	0	
	Combustion of methylamine	C-3	92.4	332	3.59	0.66	73-80

\* Values for initial specific activity of alanine are expressed as counts/min./μmole of alanine. All other values are expressed as counts/min./μmole of CO<sub>2</sub> recovered. Rel. sp. activity is specific activity relative to initial specific activity.

Table 3. *Degradation of aspartate synthesized from Na<sub>2</sub><sup>14</sup>CO<sub>3</sub> (Expt. B)*

After determination of the initial specific activity, the remaining aspartate was decarboxylated by treatment with chloramine-*T*. The activities of C-2 and C-3 of the aspartate were not determined.

Degradation stage	C of aspartate recovered as CO <sub>2</sub>	CO <sub>2</sub> recovered (μmoles)	Total radioactivity (counts/min.)	Sp. activity (counts/min./μmole)	Rel. sp. activity	Recovery (%)
Combustion of aspartate (initial sp. activity)	C-1, C-2, C-3 and C-4	57.6 (=14.4 μmoles of aspartate)	8 930	620*	1.00	
Decarboxylation of aspartate	C-1 and C-4	28.8	16 450	571	0.92	92

\* Value for initial specific activity of aspartate is expressed as counts/min./μmole of aspartate. Value for CO<sub>2</sub> is expressed as counts/min./μmole of CO<sub>2</sub> recovered. Rel. sp. activity is specific activity relative to initial specific activity.

Table 4. *Degradation of glycine*

After determination of the initial specific activity, the glycine was divided into two portions. One portion was decarboxylated with chloramine-*T*, and C-1 was collected as CO<sub>2</sub>. The second portion was treated with ninhydrin. C-2 was recovered as formaldehyde, which was successively oxidized to formate (with I<sub>2</sub>) and CO<sub>2</sub> (Hg<sup>2+</sup>).

Source of <sup>14</sup> C	Degradation stage	C of glycine recovered as CO <sub>2</sub>	CO <sub>2</sub> recovered (μmoles)	Total radioactivity (counts/min.)	Sp. activity (counts/min./μmole)	Rel. sp. activity	Recovery (%)
Na <sub>2</sub> <sup>14</sup> CO <sub>3</sub> (Expt. B)	Combustion of glycine (initial sp. activity)	{ C-1 and C-2 C-1 and C-2	32.0 (=16.0 μmoles of glycine) 32.0 (=16.0 μmoles of glycine)	416 426 414 432	26.0 26.6 25.9 27.0	1.00 1.00	
	Decarboxylation of glycine (chloramine- <i>T</i> )	{ C-1 C-1	16.0 16.0		26.3*	1.00	100
	Combustion of glycine (initial sp. activity)	C-1 and C-2	232 (=116 μmoles of glycine)	5410	46.6*	1.00	
	Decarboxylation of glycine (chloramine- <i>T</i> )	{ C-1 C-1	83.5 56.8	3800 2640	45.5 43.3	0.95	
[1- <sup>14</sup> C]Ethanol (Expt. C)	Oxidation of formaldehyde (recovered from ninhydrin decarboxylation of glycine)	C-2	140	554	4.0	0.09	104
	Combustion of glycine (initial sp. activity)	C-1 and C-2	226 (=113 μmoles of glycine)	292	2.58*	1.00	
	Decarboxylation of glycine (chloramine- <i>T</i> )	C-1	94.5	28	0.30	0.12	
	Oxidation of formaldehyde (recovered from ninhydrin carboxylation of glycine)	C-2	181	339	1.87	0.72	84

\* Values for initial specific activity of glycine are expressed as counts/min./μmole of glycine. All other values are expressed as counts/min./μmole of CO<sub>2</sub> recovered. Rel. sp. activity is specific activity relative to initial specific activity of glycine.

Table 5. *Degradation of serine synthesized from Na<sub>2</sub><sup>14</sup>CO<sub>3</sub> (Expt. B)*

After determination of the initial specific activity, and decarboxylation of a sample with chloramine-r, the serine was treated with periodate. C-1 was recovered as CO<sub>2</sub>, C-2 as formate and C-3 as formaldehyde. Formaldehyde and formate were oxidized to CO<sub>2</sub> as described in the legend to Table 4.

Degradation stage	C of serine recovered as CO <sub>2</sub>	CO <sub>2</sub> recovered (μmoles)	Total radioactivity (counts/min.)	Sp. activity (counts/min./μmole)	Rel. sp. activity	Recovery (%)
Combustion of serine (initial sp. activity)	C-1, C-2 and C-3	581 (≡ 194 μmoles of serine)	4100	21.1*	1.00	
Decarboxylation of serine (with chloramine-r)	{ C-1	84.3	1440	17.1	0.81	
	{ C-1	25.6	482	18.8	0.89	
Decarboxylation of serine (with periodate)	C-1	223	4330	19.4	0.92	
Oxidation of formate	C-2	207	99	0.48	0.02	
Oxidation of formaldehyde (via formate)	C-3	144	304	2.11	0.10	93-104

\* Value for the initial specific activity of serine is expressed as counts/min./μmole of serine. All other values are expressed as counts/min./μmole of CO<sub>2</sub> recovered. Rel. sp. activity is specific activity relative to initial specific activity.

Table 6. *Degradation of threonine synthesized from Na<sub>2</sub><sup>14</sup>CO<sub>3</sub> (Expt. B)*

After determination of the initial specific activity and decarboxylation of a sample with chloramine-r, the remainder of the threonine was degraded by treatment with periodate. C-1 was recovered as CO<sub>2</sub>, C-2 as formate and C-3 and C-4 as acetate. Formate was oxidized to CO<sub>2</sub> with Hg<sup>2+</sup>. After determination of the specific activity of the acetate, the remainder of the acetate was degraded as described earlier (Table 2).

Degradation stage	C of threonine recovered as CO <sub>2</sub>	CO <sub>2</sub> recovered (μmoles)	Total radioactivity (counts/min.)	Sp. activity (counts/min./μmole)	Rel. sp. activity	Recovery (%)
Combustion of threonine (initial sp. activity)	C-1, C-2, C-3 and C-4	399 (≡ 99.8 μmoles of threonine)	922	9.24*	1.00	
Decarboxylation of threonine (with chloramine-r)	C-1	109	434	3.98	0.43	
Decarboxylation of threonine (with periodate)	C-1	326	838	2.57	0.28	
Oxidation of formate	C-2	73.9	37	0.50	0.05	
Combustion of acetate	C-3 and C-4	79.5 (≡ 39.8 μmoles of acetate)	236	5.93*	0.64	97-112 (to this stage)
Decarboxylation of acetate	C-3	52.8	14	0.27	0.03	
Combustion of methylamine	C-4	124	412	3.32	0.36	71-86 (overall)

\* Values for the initial specific activity of threonine and the specific activity of acetate recovered from periodate oxidation are expressed as counts/min./μmole of threonine or of acetate respectively. All other values are expressed as counts/min./μmole of CO<sub>2</sub> recovered. Rel. sp. activity is specific activity relative to initial specific activity.

was recovered in the carbon dioxide when both carboxyl groups of the aspartate were removed by treatment with chloramine-T. An attempt was made to degrade aspartate from Expts. C and M, but because of the small quantity of  $^{14}\text{C}$  incorporated into aspartate in these experiments the degradations could not be completed. The results suggest that ethanol carbon atoms contribute to aspartate C-2 and C-3 almost exclusively, and that aspartate C-2 tends to arise from ethanol C-1 and aspartate C-3 from ethanol C-2.

The results of the degradation of glycine from Expts. B and C are presented in Table 4. No radioactive glycine was found among the neutral amino acids of Expt. M. C-1 of glycine arises mainly from carbon dioxide and C-2 mainly from ethanol C-1.

Table 5 shows the results of the degradation of serine from Expt. B: 80–90% of the radioactivity can be recovered from C-1, and a trace from C-3.

The results of the degradation of threonine are given in Table 6. The overall recovery of radioactivity is poor but the loss occurred in the final stage, during the degradation of acetate. It is clear that carbon dioxide contributes primarily to C-1 and C-4 of threonine, and that more than 60% of the radioactivity can be recovered from C-4. Two independent methods (treatment with chloramine-T and with periodate) gave different values for the proportion of activity in C-1, but the higher of these values is still only 43%.

*Partial degradation of glutamate.* The results of the two partial degradations of glutamate are summarized in Table 7. In both cases, the recoveries are incomplete, but the results suggest that between a quarter and a third of the activity of the molecule occurs in each carboxyl group and the remainder is found in the central three carbon atoms.

*Decarboxylation of lysine, proline, isoleucine, valine and methionine.* The results of the partial degradation of these compounds (from Expt. B) are presented in Table 8. C-1 of lysine contains 48% of the total activity of the molecule, C-1 of proline 35% and C-1 of methionine 38%. In the branched-chain amino acids all the activity occurs in C-1.

## DISCUSSION

The origins of the carbon atoms of the amino acids degraded are summarized in Table 9. In the preparation of this Table major origins only were considered and carbon atoms containing less than 10% of the total radioactivity of the compound degraded were considered, as a convention, to be non-radioactive.

The labelling patterns of alanine, aspartate and glycine and probably also those of serine and threonine are similar to those found in *Rhodospirillum rubrum* grown on acetate and carbon

Table 7. *Partial degradation of glutamate synthesized from  $\text{Na}_2^{14}\text{CO}_3$  (Expt. B)*

Degradation stage	C of glutamate recovered as $\text{CO}_2$	$\text{CO}_2$ recovered ( $\mu\text{moles}$ )	Total radioactivity (counts/min.)	Sp. activity (counts/min./ $\mu\text{mole}$ )	Rel. sp. activity	Recovery (%)
Combustion of glutamate (initial sp. activity)	C-1-C-5	559 ( $\equiv 112 \mu\text{moles}$ of glutamate)	11140	99.5*	1.00	
Decarboxylation of glutamate (with chloramine-T)	$\left\{ \begin{array}{l} \text{C-1} \\ \text{C-1} \end{array} \right.$	24.2	608	25.1	0.26	26.1
		121	3270	27.0		
Combustion of succinate	C-2-C-5	281 ( $\equiv 70.3 \mu\text{moles}$ of succinate)	3530	50.2*	0.50	76
		77.8	2340	30.1	0.30	
Decarboxylation of glutamate (with azide)	C-5	448 ( $\equiv 112 \mu\text{moles}$ of diaminobutyrate)	5170	46.2*	0.46	76
Combustion of diaminobutyrate	C-1-C-4					

\* Values for initial specific activity of glutamate and of specific activities of recovered succinate and diaminobutyrate are expressed as counts/min./ $\mu\text{mole}$  of glutamate, succinate or diaminobutyrate. All other values are expressed as counts/min./ $\mu\text{mole}$  of  $\text{CO}_2$  recovered. Rel. sp. activity means specific activity relative to initial specific activity of glutamate.

After determination of the initial specific activity, the glutamate remaining was divided into two portions. One was decarboxylated at C-1 with chloramine-T. C-2-C-5 were recovered as succinate, which was subjected to combustion. The second portion was decarboxylated at C-5 by treatment with azide. The residue, assumed to be diaminobutyrate, was subjected to combustion.



Table 8. *Partial degradation of amino acids synthesized from Na<sub>2</sub><sup>14</sup>CO<sub>3</sub> (Expt. B)*

After determination of the initial specific activity, the remainder of the amino acid was decarboxylated at C-1 by treatment with chloramine-r.						
Amino acid	Degradation stage	C of amino acid recovered as CO <sub>2</sub>	CO <sub>2</sub> recovered (μmoles)	Total radioactivity (counts/min.)	Sp. activity (counts/min./μmole)*	Rel. sp. activity
Lysine	Combustion (initial sp. activity)	C-1-C-6	607 (≡ 101 μmoles of lysine)	3370	33.4	1.00
	Decarboxylation	C-1	852	12560	15.9	0.48
Proline	Combustion (initial sp. activity)	C-1-C-5	554 (≡ 111 μmoles of proline)	5620	50.6	1.00
	Decarboxylation	C-1	247	4410	17.8	0.35
Isoleucine	Combustion (initial sp. activity)	All	253 (≡ 42.2 μmoles of isoleucine)	1110	26.3	1.00
	Decarboxylation	C-1	27.1	736	27.2	1.03
Valine	Combustion (initial sp. activity)	All	238 (≡ 47.6 μmoles of valine)	3410	65.9	1.00
	Decarboxylation	C-1	75.1	5200	69.2	1.05
Methionine	Combustion (initial sp. activity)	All	187 (≡ 37.4 μmoles of methionine)	295	7.89	1.00
	Decarboxylation	C-1	67.5	202	2.99	0.38

\* Initial specific activities of amino acids are expressed as counts/min./μmole of amino acid. Specific activities of recovered CO<sub>2</sub> are expressed as counts/min./μmole of CO<sub>2</sub>.

Table 9. *Origin of amino acid carbon atoms in Methanobacterium omelianskii*

Carbon atoms are derived: b, from CO<sub>2</sub>; e, from ethanol (ethanol carbon atom not determined); c, from ethanol C-1; m, from ethanol C-2.

Carbon atom no. ...	1	2	3	4	5
Alanine	b	c	m		
Aspartate	b	c	m	b	
Glycine	b	c			
Serine	b	e	e		
Threonine	b	e	e	b	
Glutamate	b	b/e	b/e	b/e	b
Carbon atom no. ...	1	Remainder			
Lysine	b	b & e			
Proline	b	b & e			
Isoleucine	b	e			
Valine	b	e			
Methionine	b	b & e			

dioxide (Cutinelli *et al.* 1951a,b) and in *Clostridium kluyveri* grown on labelled carbon dioxide or ethanol (Tomlinson, 1954a). The labelling patterns of alanine and aspartate are also similar to those found in *Chlorobium thiosulphatophilum* grown in the presence of labelled acetate (Hoare & Gibson, 1964).

The labelling pattern of alanine is consistent with the synthesis of alanine from pyruvate made by the ferredoxin-dependent carboxylation of acetyl-CoA, demonstrated in cell-free extracts of *Clostridium kluyveri* (Andrew & Morris, 1965) and *Chromatium* (Buchanan, Bachofen & Arnon, 1964). The synthesis of pyruvate from acetaldehyde + carbon dioxide by extracts of *M. omelianskii* has been demonstrated (Brill, 1965) and it has been shown that the organism does contain ferredoxin (Wolin *et al.* 1963; Buchanan & Rabinowitz, 1964). The presence in *M. omelianskii* of an alanine dehydrogenase (aminating) has been demonstrated by Allam (1965).

The characteristic labelling patterns of aspartate, serine, glycine and threonine are consistent with their synthesis from pyruvate synthesized by the carboxylation of acetyl-CoA. The labelling pattern of aspartate suggests that it is synthesized by transamination of oxaloacetate formed by carboxylation of pyruvate. That of threonine, though incomplete, is partly consistent with its synthesis from aspartate by reactions known in other organisms (Umberger & Davis, 1962). The fact that C-1 and C-4 are unequally labelled might be due to a second pathway of synthesis involving a contribution of ethanol carbon atoms to C-1 of threonine.

Although the origin of all three carbon atoms of serine has not been fully established, it is probable that it is like that of alanine, and that serine is synthesized from pyruvate by a route that does not involve breakage of the carbon chain. It has been

Table 10. *Labelling patterns in glutamate*

Carbon atoms are derived: b, from CO<sub>2</sub>; e, from ethanol (ethanol carbon not determined); c, from ethanol or acetate C-1; m, from ethanol or acetate C-2.

Carbon atom no. ...	...	1	2	3	4	5
Organism						
Aerobic (via tricarboxylic acid cycle)		b	m	m	m	c
<i>R. rubrum</i>		b	c	m	m	c
<i>Cl. kluuyveri</i>		c	m	c	m	b
<i>M. omelianskii</i> (observed)		b	b/e	b/e	b/e	b
<i>M. omelianskii</i> (predicted via tricarboxylic acid cycle)		b	m	c	m	c

shown that in *E. coli* serine is synthesized from 3-phosphoglycerate by a pathway involving phosphorylated intermediates (Umbarger, Umbarger & Siu, 1963). The enzymes of this pathway have been shown to occur in the strict anaerobe, *Peptostreptococcus elsedenii* (Somerville, 1965), but have not yet been demonstrated in *M. omelianskii*. The labelling pattern of glycine is consistent with its formation from serine by the action of serine aldolase (serine hydroxymethylase), as has been shown to be the case in *E. coli* (Pizer, 1965). Serine hydroxymethylase occurs in *M. omelianskii*, and is involved in the formation of methane from serine by cell-free extracts (J. M. Wood, personal communication.)

The results of the degradation of glutamate from Expt. B show that the labelling pattern differs both from that found in *Rhodospirillum rubrum* grown on acetate (Cutinelli *et al.* 1951a; Hoare, 1963) and from that found in *Clostridium kluuyveri* (Tomlinson, 1954b). In all three cases the pattern differs from that found in aerobes; nor is it consistent with synthesis of the carbon skeleton from oxaloacetate (with a labelling pattern similar to that found in aspartate) plus acetate by reactions of part of the tricarboxylic acid cycle. The different labelling patterns are shown in Table 10.

The labelling pattern proposed for the glutamate of *M. omelianskii* is based on the results described in Table 7. The results of each of the partial degradations suggests that there is about one-third of the total radioactivity in each of the two carboxyl groups. This suggests that, of the three central carbon atoms, one is derived from carbon dioxide and the remaining two from ethanol. Glutamate derived from the Expts. C and M was too inactive to make degradation worth while. Without knowledge of where ethanol carbon atoms contribute to the glutamate molecule it is not possible to speculate about the pathway by which glutamate may be synthesized.

The proportion of total radioactivity found in C-1 of lysine, proline, methionine and valine is con-

sistent with their synthesis by the routes known to occur in *E. coli* and other organisms (Umbarger & Davis, 1962). The lysine carbon skeleton is formed by the condensation of aspartic semialdehyde with pyruvate to give, ultimately, diaminopimelic acid, of which C-1 and C-4 are derived from C-1 and C-4 of aspartate and C-7 from C-1 of pyruvate. C-7 is lost during the conversion of diaminopimelate into lysine. If lysine were synthesized in *M. omelianskii* by this pathway, C-1 and C-4 would be derived from carbon dioxide. In the aerobic pathway of synthesis the carbon skeleton of proline is derived directly from glutamate. The proportion of activity in C-1 of proline (35%) derived from Expt. B agrees quite well with that found in glutamate C-1. Since in the aerobic pathway the C<sub>4</sub> chain of methionine is directly derived from that of aspartate, it would be expected that, if this were the route of synthesis in *M. omelianskii*, C-1 and C-4 would be derived from carbon dioxide. The fact that only 38% of the total activity is recovered from C-1 might be accounted for by a contribution of carbon dioxide carbon atoms to the methyl group of methionine. The labelling pattern of valine suggests that it also may be synthesized by the aerobic pathway. This entails condensation of a C<sub>2</sub> unit derived from pyruvate C-2 and C-3 with pyruvate to give a C<sub>5</sub> oxo acid, of which C-1 (which becomes C-1 of valine) is the only atom derived from carbon dioxide.

In isoleucine, however, the situation is different. In the pathway found in aerobes a C<sub>2</sub> unit derived from pyruvate condenses with 2-oxobutyrate, which is derived from threonine. If this pathway were involved in isoleucine synthesis in *M. omelianskii*, then C-1 and C-4 of 2-oxobutyrate would be derived from carbon dioxide, and only 50% of the total radioactivity of the molecule should have been found in C-1, instead of 100%. Allison & Bryant (1963) have shown that in *Ruminococcus flavefaciens* the branched-chain amino acids are synthesized by carboxylation of the corresponding C<sub>4</sub> or C<sub>5</sub> branched-chain fatty acids. It may be that isoleucine is synthesized by a similar reaction in *M. omelianskii*. If so, it is possible that valine might be synthesized by a similar reaction, since the labelling pattern found is not inconsistent with this. In the aerobic pathway of synthesis isoleucine and valine are synthesized by common reactions, probably catalysed by the same enzymes. If the enzymes were present for synthesis of valine by the conventional pathway, then isoleucine could also have been made by the same route.

The work described was undertaken partly to determine the relative importance of carbon dioxide and ethanol as sources of carbon in the biosynthesis of amino acids by *M. omelianskii* and partly to determine something of the pathways by which the amino acids are synthesized in *M. omelianskii*. It

has been shown that both ethanol and carbon dioxide carbon atoms are used in amino acid biosynthesis in *M. omelianskii*, and that, since in many cases ethanol is incorporated as a C<sub>2</sub> unit, use of ethanol carbon atoms is not preceded by its oxidation to carbon dioxide. The virtual absence of carbon dioxide carbon from certain atoms in some molecules (e.g. C-2 and C-3 of alanine, aspartate, serine and threonine) in an organism growing on a minimal medium implies equal importance of carbon dioxide and ethanol as carbon sources.

The origins of carbon atoms revealed by degradation are almost all consistent with the synthesis of amino acids by pathways already observed in other organisms. With the exception of glutamate, alanine, isoleucine and perhaps valine, the pathways of synthesis are probably similar to those found in aerobic organisms.

The authors thank Mr R. Bacon and Mr A. A. Hancock for technical assistance. The work was started while R. S. W. held a Guggenheim Fellowship. The work was partially supported by the Rockefeller Foundation.

#### REFERENCES

- Allam, A. (1965). Ph.D. Thesis: University of Illinois.
- Allison, M. J. & Bryant, M. P. (1963). *Arch. Biochem. Biophys.* **101**, 269.
- Allison, M. J., Bryant, M. P. & Doetsch, R. N. (1962). *J. Bact.* **83**, 523.
- Andrew, I. G. & Morris, J. G. (1965). *Biochim. biophys. Acta*, **97**, 176.
- Aronoff, S. (1956). *Techniques of Radiobiochemistry*, p. 188. Ames, Iowa: Iowa State College Press.
- Bassham, J. A. & Calvin, M. (1957). *The Path of Carbon in Photosynthesis*, p. 19. Englewood Cliffs, N.J.: Prentice-Hall Inc.
- Benson, A. A., Bassham, J. A., Calvin, M., Goodale, T. C., Haas, V. A. & Stepka, W. (1950). *J. Amer. chem. Soc.* **72**, 1710.
- Brill, W. J. (1965). Ph.D. Thesis: University of Illinois.
- Buchanan, B. B., Bachofen, R. & Arnon, D. I. (1964). *Proc. nat. Acad. Sci., Wash.*, **52**, 839.
- Buchanan, B. B. & Rabinowitz, J. C. (1964). *J. Bact.* **88**, 806.
- Cohen, P. P. (1940). *J. biol. Chem.* **136**, 565.
- Crawford, L. V. (1958). *Biochem. J.* **68**, 221.
- Cutinelli, C., Ehrensward, G., Högström, G., Reio, L., Saluste, E. & Stjernholm, R. (1951b). *Ark. Kemi*, **3**, 501.
- Cutinelli, C., Ehrensward, G., Reio, L., Saluste, E. & Stjernholm, R. (1951a). *Ark. Kemi*, **3**, 315.
- Elsden, S. R. & Gibson, Q. H. (1954). *Biochem. J.* **58**, 154.
- Hardy, T. L., Holland, D. O. & Nayler, J. H. C. (1955). *Analyt. Chem.* **27**, 971.
- Hausmann, W. (1952). *J. Amer. chem. Soc.* **74**, 3181.
- Hoare, D. S. (1963). *Biochem. J.* **87**, 284.
- Hoare, D. S. & Gibson, J. (1964). *Biochem. J.* **91**, 546.
- Ingram, V. M. & Stretton, A. O. W. (1962). *Biochim. biophys. Acta*, **62**, 456.
- Johns, A. T. & Barker, H. A. (1960). *J. Bact.* **80**, 837.
- Kemble, A. R. & Macpherson, H. T. (1954). *Biochem. J.* **56**, 548.
- Knight, M. (1962). *Biochem. J.* **84**, 170.
- Markham, R. (1942). *Biochem. J.* **36**, 790.
- Pizer, L. I. (1965). *J. Bact.* **89**, 1145.
- Richmond, V. & Hartley, B. S. (1959). *Nature, Lond.*, **184**, 1869.
- Rollins, C., Jensen, L. & Schwartz, A. N. (1962). *Analyt. Chem.* **34**, 711.
- Ryle, A. P., Sanger, F., Smith, L. F. & Kitai, R. (1955). *Biochem. J.* **60**, 541.
- Sakami, W. (1955). *Handbook of Isotope Tracer Methods*. Cleveland, Ohio: Western Reserve University.
- Schnellen, C. G. T. P. (1947). *Onderzoekingen over de Meet-hangisting*, p. 92. Rotterdam, Netherlands: De Maastad.
- Somerville, H. J. (1965). Ph.D. Thesis: University of Sheffield.
- Tomlinson, N. (1954a). *J. biol. Chem.* **209**, 597.
- Tomlinson, N. (1954b). *J. biol. Chem.* **209**, 605.
- Umbarger, H. E. & Davis, B. D. (1962). In *The Bacteria*, vol. 3, p. 167. Ed. by Gunsalus, I. C. & Stanier, R. Y. New York: Academic Press Inc.
- Umbarger, H. E., Umbarger, M. A. & Siu, P. M. L. (1963). *J. Bact.* **85**, 1431.
- Wall, J. S. (1953). *Analyt. Chem.* **25**, 950.
- Wolin, E. A., Wolin, M. J. & Wolfe, R. S. (1963). *J. biol. Chem.* **238**, 2882.
- Yemm, E. W. & Cocking, E. C. (1955). *Analyst*, **80**, 209.