

dissociations of these salts to be considered quantitatively in any kinetic or other study of phosphate, glucose 1-phosphate or glycerol 2-phosphate in the presence of magnesium ions.

The authors wish to thank Dr E. M. Crook for his invaluable advice and encouragement. They also wish to thank the Central Research Fund of the University of London for a grant to purchase the potentiometric equipment used in this work. One of the authors (H. B. C.) thanks the Department of Scientific and Industrial Research for a personal grant.

#### REFERENCES

- Ashby, J. H., Crook, E. M. & Datta, S. P. (1954*a*). *Biochem. J.* **56**, 190.  
 Ashby, J. H., Crook, E. M. & Datta, S. P. (1954*b*). *Biochem. J.* **56**, 198.  
 Bates, R. C. & Acree, S. F. (1943). *J. Res. nat. Bur. Stand.* **30**, 129.  
 Burton, K. & Krebs, H. A. (1953). *Biochem. J.* **54**, 94.  
 Cannan, R. K. & Kibrick, A. C. (1938). *J. Amer. chem. Soc.* **60**, 2314.  
 Evans, J. I. & Monk, C. B. (1952). *Trans. Faraday Soc.* **48**, 934.  
 Greenwald, I., Redish, J. & Kibrick, A. C. (1940). *J. biol. Chem.* **135**, 65.  
 Güntelberg, E. (1926). *Z. phys. Chem.* **123**, 199.  
 Harned, H. S. & Robinson, R. A. (1940). *Trans. Faraday Soc.* **36**, 973.  
 Jones, H. W. & Monk, C. B. (1952). *Trans. Faraday Soc.* **48**, 929.  
 Please, N. W. (1954). *Biochem. J.* **56**, 196.  
 Roche, J. (1950). In *The Enzymes*, 1 (1), 473. Ed. J. B. Sumner and K. Myrbäck. Academic Press Inc.  
 Stock, D. I. & Davies, C. W. (1948). *Trans. Faraday Soc.* **44**, 856.  
 Tabor, H. & Hastings, A. B. (1943). *J. biol. Chem.* **148**, 627.  
 Trevelyan, W. E., Mann, P. F. E. & Harrison, J. S. (1952). *Arch. Biochem. Biophys.* **39**, 440.

## The Estimation of Lactic Acid using Ceric Sulphate

By S. R. ELSDEN AND Q. H. GIBSON

*Agricultural Research Council Unit of Microbiology, Department of Microbiology;  
 and Department of Physiology, University of Sheffield*

(Received 6 March 1954)

Gordon & Quastel (1939) showed that ceric sulphate oxidizes lactic acid according to the following equation:

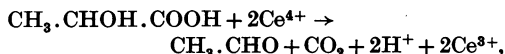

and they made this reaction the basis of a method for the estimation of lactic acid. The reaction was carried out at 50° and the acetaldehyde so formed was removed by a stream of nitrogen, trapped in bisulphite and estimated iodometrically in the usual way. The advantages claimed for this procedure were simplicity and the fact that very few compounds gave rise to volatile aldehydes under the experimental conditions recommended by the authors. Glucose in particular did not interfere and a preliminary treatment of glucose-containing test solutions with the copper-lime reagent was not considered necessary.

In its essentials the method devised by Long (1946) was similar to that of Gordon & Quastel (1939). He showed, however, that ceric sulphate oxidizes acetaldehyde to acetic acid; but in spite of this he was able to obtain good yields of acetaldehyde from lactic acid by aerating very rapidly, thus removing the acetaldehyde almost as fast as it was formed. The aeration rate recommended was 500 ml. air/min. as compared with the three to four

bubbles nitrogen/sec. advised by Gordon & Quastel.

Winnick (1942) carried out the reaction in Conway vessels with bisulphite in the central chamber to trap the acetaldehyde and incubated for 2 hr. at 50°. His method was modified by Conway (1950), who carried out the oxidation in stoppered test tubes. After 30 min. incubation at 37°, he transferred 1 ml. samples of the reaction mixture to diffusion vessels where the acetaldehyde was trapped in bisulphite placed in the centre chamber.

In view of the widely divergent conditions recommended by the various authors, it seemed desirable, before using any of the ceric sulphate methods, to examine the various steps in the procedure further. The results of these investigations are given below.

#### EXPERIMENTAL AND RESULTS

##### *Factors influencing the oxidation of lactic acid by ceric sulphate*

*Effect of ceric sulphate concentration and temperature on the velocity of the reaction.* Since carbon dioxide is one of the products of the reaction, Warburg manometers were used to study the effect of both temperature and concentration of ceric sulphate on the velocity of the reaction. The reaction was carried out in *N* sulphuric acid and 0.2 ml. lithium lactate solution in *N* sulphuric acid was added from the side

bulb when thermal equilibrium had been attained. In Fig. 1 are plotted the half times for the reaction at 22, 40 and 53°. It will be seen that the concentration of ceric sulphate has a pronounced effect and that at 53° the half time is less than 5 min. even with the most dilute solution of ceric sulphate tested.

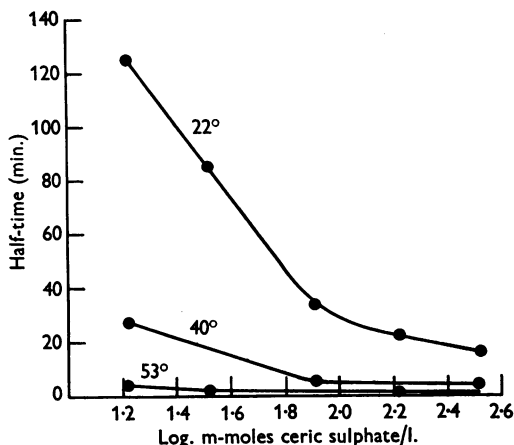

Fig. 1. Effect of temperature and ceric sulphate concentration on the velocity of oxidation of lactic acid. Experiments were carried out in Warburg manometers. 11.1  $\mu$ -moles lithium lactate in 0.2 ml.  $N-H_2SO_4$  were added from side bulb at zero time; main compartment contained 2.8 ml. ceric sulphate in sulphuric acid; gas phase, air.

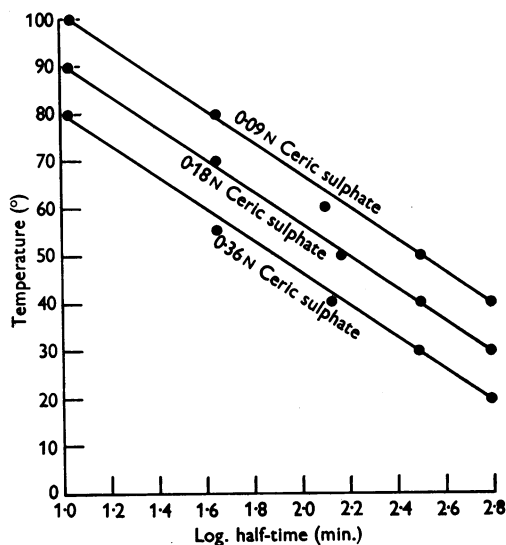

Fig. 2. Effect of temperature and ceric sulphate concentration on the velocity of oxidation of acetaldehyde. Experiments were carried out in an apparatus similar to that of Long (1946). Volume of reactants, 10 ml.; each tube contained 26.2  $\mu$ moles acetaldehyde; concentration of sulphuric acid,  $N$ . Reaction was stopped by the addition of excess of ferrous sulphate and residual acetaldehyde aerated into bisulphite and estimated iodometrically.

*Oxidation of acetaldehyde by ceric sulphate.* Acetaldehyde and ceric sulphate were incubated in Long's apparatus at various temperatures and, at suitable time intervals, the residual ceric sulphate was reduced to the cerous form by addition of excess of ferrous sulphate. The acetaldehyde remaining was then transferred by aeration to bisulphite solution and estimated iodometrically. The test solution contained 26.2  $\mu$ moles acetaldehyde, and the total volume including the ceric sulphate solution was 10 ml. The final concentration of sulphuric acid was normal in all cases. The results are given in Fig. 2 in which the log of the half-time of acetaldehyde destruction is plotted against temperature for three different concentrations of ceric sulphate. It will be seen that the rate of oxidation of acetaldehyde is greater the higher the temperature and the greater the ceric sulphate concentration.

*Removal of acetaldehyde by aeration.* The effects of temperature and velocity of aeration on the rate of removal of acetaldehyde were next examined. These experiments were conducted in an apparatus of the form and dimensions recommended by Long (1946). The volume of the reaction mixture was 10 ml. containing 20  $\mu$ moles of acetaldehyde in  $N$  sulphuric acid. Air was blown through the mixture and the acetaldehyde was trapped in bisulphite. The rate of air flow was measured with a flow meter. After suitable intervals of time, aeration was stopped and the acetaldehyde trapped in the bisulphite determined iodometrically. The experiments were carried out with flows of 200–1000 ml. air/min.

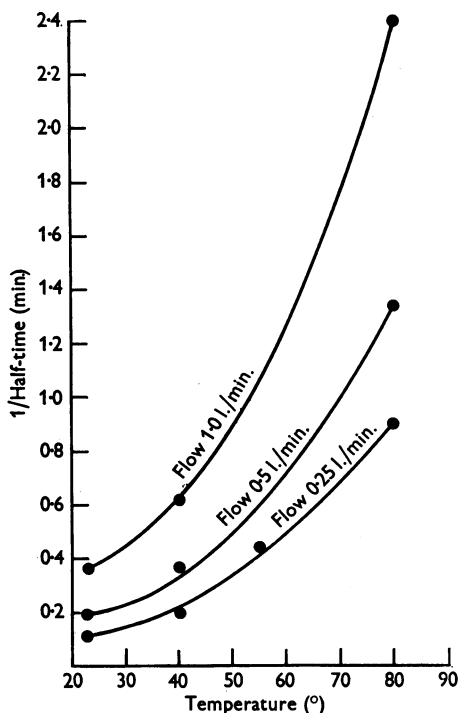

Fig. 3. Effect of rate of air flow and temperature on the rate of removal of acetaldehyde. Experiments were carried out in apparatus similar to that of Long (1946). Each apparatus contained 20  $\mu$ moles acetaldehyde in 10 ml.  $N$  sulphuric acid. Acetaldehyde was trapped in bisulphite and estimated iodometrically.

Table 1. *Recovery of lactic acid by aeration method*

Each reaction tube contained a total volume of 10 ml. mixture which was normal with respect to  $\text{H}_2\text{SO}_4$  and contained 500  $\mu\text{equiv.}$  ceric sulphate;  $T = 60^\circ$ , aeration rate = 500 ml./min.,  $t = 45$  min.

Expt. no. ... ..	1	2	3	4
Zinc lactate added (as $\mu\text{moles}$ lactic acid)	5.65	11.3	22.4	112.9
No. of blanks	2	2	2	2
No. of estimations	4	4	4	4
Mean blank value ( $\mu\text{moles}$ lactic acid)	1.13	0.87	1.37	0.97
Mean recovery corrected for blanks ( $\mu\text{moles}$ lactic acid)	5.39	11.2	22.2	109.6
Range	5.00-5.69	10.88-11.91	21.11-22.40	107.9-110.7

and at temperatures from 20 to  $80^\circ$ . The results are given in Fig. 3. Over the range studied the rate of removal of acetaldehyde was found to be approximately proportional to (air flow) $^{0.75}$  and to the vapour pressure of acetaldehyde which would exist over pure acetaldehyde at the temperature of the experiment.

*Working conditions for the aeration method.* The results of the above experiments show that, for a given air flow, increasing either the ceric sulphate concentration or the temperature will diminish the recovery of acetaldehyde. These experiments have enabled us to define working conditions which permit a good recovery of acetaldehyde from lactic acid. We recommend an initial concentration of ceric sulphate of 0.05  $N$ , a temperature of  $50$ – $60^\circ$ , an aeration rate of 500–600 ml. air/min./reaction tube and an aeration time of at least 45 min. Representative recoveries using these conditions are given in Table 1.

#### *Steam distillation method*

Although the aeration method gives satisfactory recoveries, the blanks were substantial, due to the contamination of the laboratory air with carbonyl compounds. We therefore examined alternative ways of carrying out the reaction. The results described above show that to obtain the greatest rates of formation and the smallest losses of acetaldehyde, it is desirable to work at as high a temperature as is compatible with the maximum usable rate of aeration and the minimum concentration of ceric sulphate. Steam distillation seemed to offer the best possibility, and preliminary experiments in which the reaction was carried out in the apparatus of Markham (1942) indicated that at  $100^\circ$  the reaction was complete in a very short time and that the acetaldehyde could be distilled over into bisulphite in about 10 ml. of distillate. However, losses were encountered and these we considered to be due to the fact that all the ceric sulphate had to be added at once, with the result that, at the temperature of the mixture, the amount of ceric sulphate present was sufficient to oxidize significant amounts of acetaldehyde. We therefore designed an apparatus in which it was possible to add the ceric sulphate dropwise whilst the steam was passing. The apparatus, which has proved entirely satisfactory, is shown in Fig. 4. The following reagents are required: (i) 0.05  $N$  ceric sulphate in  $N$  sulphuric acid prepared from a stock solution of 0.5  $N$  ceric sulphate in  $N$  sulphuric acid. The stock ceric sulphate is standardized with ferrous ammonium sulphate. We have found ceric sulphate (pure), Hopkin & Williams, to be satisfactory. (ii) 10  $N$  sulphuric acid. (iii) 0.5% (w/v) sodium bisulphite solution. (iv) 0.1  $N$ , 0.01  $N$  and 0.005  $N$  iodine solution.

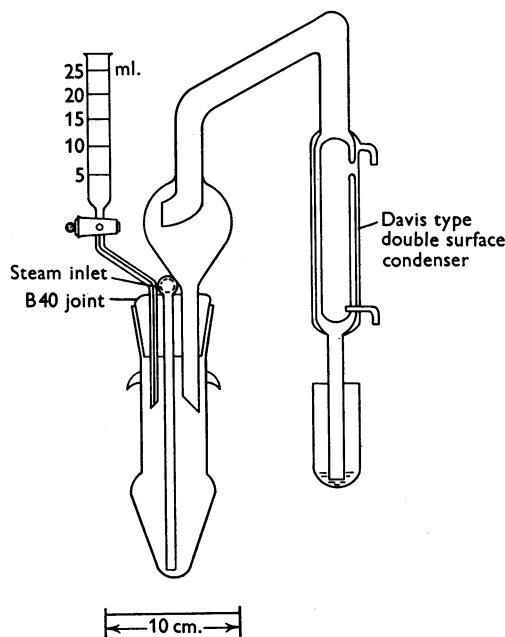

Fig. 4. Apparatus for the estimation of lactic acid by the steam-distillation method.

The sample containing lactic acid, which preferably should not exceed 5 ml., is measured into the reaction flask and sufficient of the 10  $N$  sulphuric acid added to make the concentration of this acid normal. The reaction flask is then attached to the apparatus. The receiving tube which contains 2 ml. of the 0.5% (w/v) sodium bisulphite is attached in such a way that the tip of the condenser dips below the surface of the bisulphite solution. The micro-burner heating the reaction flask is now turned on and the flame adjusted so that the solution just boils. The steam is then turned on and the steam flow adjusted so that 15–20 ml./min. of distillate is collected (this rapid distillation rate is essential and necessitates the use of an efficient double surface condenser); the 0.05  $N$  ceric sulphate is then run dropwise into the reaction flask at such a rate that each drop is decolorized before the next drop goes in. When a permanent yellow colour is obtained, indicating that an excess of ceric sulphate is present, further ceric sulphate up to a total of 5 ml. is rapidly added. The only critical feature of the

Table 2. *Recovery of lactic acid by the steam distillation method*

In Expt. 1, 0.002574N-I<sub>2</sub> was used for final titration; blank titration 0.08 ml. 0.002574N-I<sub>2</sub>, and the results corrected for this amount. In remaining experiments 0.01287N-I<sub>2</sub> used and the blank was too small to be measured.

Expt. no. ...	1	2	3	4
No. of estimations	6	6	6	6
Lactic acid taken ( $\mu$ moles)	2.17	10.85	21.70	32.55
Mean lactic acid recovered ( $\mu$ moles)	2.14	10.64	21.13	31.82
s.e.	$\pm 0.02$	$\pm 0.05$	$\pm 0.03$	$\pm 0.10$
Range	2.08-2.16	10.60-10.73	21.07-21.14	31.61-31.87

estimation is the dropwise addition of ceric sulphate. When 15 ml. of distillate have been collected the receiver is lowered and distillation is continued until 20 ml. has been collected. The steam is then discontinued, the microburner turned out and the receiver placed in an ice-water bath to cool. While it is cooling, the reaction flask is disconnected and thoroughly washed out with distilled water. The still head is also carefully washed to remove traces of ceric sulphate solution, which, if left, could bring about the premature oxidation of part of the lactic acid in the next sample to be analysed.

The acetaldehyde is then estimated in the usual way, using solid NaHCO<sub>3</sub> to destroy the aldehyde bisulphite compound. Like Friedemann & Graesser (1933) we have found that it is important to cool the mixture thoroughly before the final titration; the temperature should be 4-5°. The results of a series of recovery experiments are given in Table 2.

Under the conditions of this method, glucose gives rise to carbonyl compounds, and we have found it essential to treat the test solution with the copper-lime reagent; for this purpose we use 1 ml. 20% (w/v) CuSO<sub>4</sub>, 5H<sub>2</sub>O/10 ml. test solution and a spatula full of solid Ca(OH)<sub>2</sub>. This reagent will also effectively deproteinize bacterial suspensions and rumen liquor.

Trichloroacetic acid cannot be used, since under the conditions of the estimation it is oxidized with formation of such large volumes of gas that frothing is uncontrollable. The various methods for the precipitation of proteins which involve the use of tungstic acid have however proved entirely satisfactory. We have also found that perchloric acid (Neuberg, Strauss & Lipkin, 1944) is very satisfactory where an acid precipitation is required. If perchloric acid treatment is followed by treatment with the copper-lime reagent we have found it convenient to add the copper solution followed by 2N-KOH until a slight trace of cupric hydroxide is formed, at which point the lime is added. In this way the perchloric acid is removed as the insoluble potassium salt. The removal of perchloric acid is not essential.

Protein hydrolysates, such as are used in bacteriological media cause some interference, but no carbonyl compounds were produced from ethanol, from citric acid or from malic acid.

The results of an experiment in which the lactic acid, formed from malic acid by *Lactobacillus arabinosus* under the conditions described by Nossal (1951), was estimated both manometrically and by the steam distillation method after treatment of the mixture with copper-lime, are given in Table 3. Table 4 shows the results obtained when a sample of blood was analysed in triplicate by the steam distillation method.

Table 3. *Estimation of lactic acid formed from DL-malic acid by the action of the malic decarboxylase of Lactobacillus arabinosus*

The malic decarboxylase converts L-malic acid quantitatively into lactic acid and CO<sub>2</sub>, and the amount of CO<sub>2</sub> formed is thus a measure of the amount of lactic acid. In this experiment a solution of DL-malic acid was treated with the decarboxylase preparation according to the procedure of Nossal (1951), and at the end of the experiment the cup contents were transferred quantitatively to a measuring cylinder, treated with the copper-lime reagent, made up to 10 ml. and centrifuged; samples of the supernatant solution were used for the estimation of lactic acid by the steam distillation method. Strength of iodine, 0.002754N.

	CO <sub>2</sub> ( $\mu$ moles)	Lactic acid ( $\mu$ moles)
Manometric method	9.37	9.37
Steam distillation method		
(a)	—	9.35
(b)	—	8.92

Table 4. *Estimation of lactic acid in defibrinated sheep's blood by the steam distillation method*

Three 2 ml. samples of defibrinated sheep's blood were taken and 7 ml. of distilled water added to each followed by 2 ml. 15% (w/v) perchloric acid. Precipitates were centrifuged off and supernatants filtered through cotton wool into graduated centrifuge tubes; 0.5 ml. 20% (w/v) CuSO<sub>4</sub>, 5H<sub>2</sub>O was added and 40% (w/v) KOH added dropwise until a slight permanent blue precipitate obtained, a spatula full of solid Ca(OH)<sub>2</sub> (approx. 1 g.) added, the contents of the tubes were mixed and the volumes noted. After 30 min. tubes were centrifuged and 5 ml. samples taken for analysis.

Sample	Lactic acid $\mu$ moles/100 ml. blood
1	193
2	197
3	200

## DISCUSSION

Our observations on the reaction between ceric sulphate and lactic acid confirm and amplify those published by Long (1946). Significant amounts of the acetaldehyde produced are oxidized to acetic acid if the former is not rapidly removed from the reaction mixture. The rate of destruction of acetaldehyde is related to the concentration of ceric

sulphate in the reaction mixture and to the temperature. Consequently, to obtain maximum recovery of acetaldehyde, the concentration of ceric sulphate should be such as to ensure only a slight excess at the end of the reaction. The rate of aeration should be the maximum possible. From our results it would appear that the concentration of ceric sulphate recommended by Long (1946) is somewhat too high.

In view of our findings it is difficult to understand how a quantitative conversion of lactic acid to acetaldehyde can be obtained by the procedure of Winnick (1942). This author recommends a mixture of 3 ml. sample and 1 ml. saturated ceric sulphate and the reaction is carried out in Conway vessels and thus relies upon diffusion to remove the acetaldehyde. Since the purity of his ceric sulphate is not stated we can only guess at the final concentration, but it would seem to be in the region of 0.2N. Likewise the modification of Winnick's procedure described by Conway (1950) is open to serious criticism in the light of the observations of both Long (1946) and ourselves. In this method the reaction is carried out in stoppered test tubes, under conditions somewhat similar to those used both by Long and ourselves to study the oxidation of acetaldehyde by ceric sulphate.

It is possible to remove the acetaldehyde formed from lactic acid, almost quantitatively, either by aeration or by steam distillation, and we have examined both procedures. We prefer the steam distillation method for the following reasons. The blanks are negligible save when using 0.00257N iodine; but even here they are small and are equivalent to about 0.1  $\mu$ mole lactic acid. The method is extremely rapid, one distillation taking little more than a minute to perform. The end point is sharper because the final volume in which the titration is carried out is only 30 ml. and this is particularly important when small amounts of lactic acid are to be estimated. The advantages of

this ceric sulphate method over the permanganate methods, described by Friedemann, Cotonio & Shaffer (1927), Friedemann & Kendall (1929), and Friedemann & Graeser (1933) are speed and the small volume in which the titration is carried out.

#### SUMMARY

1. The effect of ceric sulphate concentration and temperature on the oxidation of lactic acid by ceric sulphate have been investigated.
2. The effects of temperature and rate of aeration on the removal of acetaldehyde from solutions have been investigated.
3. Conditions for the estimation of lactic acid with ceric sulphate using the aeration method are described.
4. A new method for the estimation of lactic acid using ceric sulphate and the removal of acetaldehyde by steam distillation is described.

The authors wish to thank Mrs M. Martin for technical assistance and Mr Hatfield for making and helping with the design of the apparatus.

#### REFERENCES

- Conway, E. J. (1950). *Microdiffusion Analysis and Volumetric Error*, 3rd ed. p. 241. London: Crosby Lockwood and Son Ltd.
- Friedemann, T. E., Cotonio, M. & Shaffer, P. A. (1927). *J. biol. Chem.* **73**, 335.
- Friedemann, T. E. & Graeser, J. B. (1933). *J. biol. Chem.* **100**, 291.
- Friedemann, T. E. & Kendall, A. I. (1929). *J. biol. Chem.* **82**, 23.
- Gordon, J. J. & Quastel, J. H. (1939). *Biochem. J.* **33**, 1332.
- Long, C. (1946). *Biochem. J.* **40**, 27.
- Markham, R. (1942). *Biochem. J.* **36**, 790.
- Neuberg, C., Strauss, E. & Lipkin, L. E. (1944). *Arch. Biochem.* **4**, 101.
- Nossal, P. M. (1951). *Biochem. J.* **50**, 349.
- Winnick, T. (1942). *J. biol. Chem.* **142**, 451.

## Active Transport of Sodium Ions from the Yeast Cell

By E. J. CONWAY, H. RYAN AND ENID CARTON  
*Department of Biochemistry, University College, Dublin*

(Received 12 November 1953)

It has been shown (Conway & Hingerty, 1948) that sodium ions which had entered muscle extensively in rats on a potassium-free diet were actively extruded on changing the animals to a potassium-rich diet. The mean half period of extrusion, even with the plasma potassium above the normal level within 24 hr. after the change, was about 3 days.

Very recently, Desmedt (1953) has described a more rapid net excretion of sodium ions from the isolated frog sartorius in which sodium ions had entered extensively after immersion in a potassium-free Ringer solution in the manner described by Steinbach (1951). To demonstrate the excretion, companion muscles which were similarly treated