

- Koshtoyants, Kh. S. & Yanson, Z. A. (1950). *C.R. Acad. Sci. U.R.S.S.* **75**, 881. Through *Chem. Abstr.* **46**, 5159 (1952).
- Koval'skiĭ, V. V. (1947). *C.R. Acad. Sci. U.R.S.S.* **58**, 1083.
- Koval'skiĭ, V. V. (1948). *Biochemistry, Leningr.*, **13**, 131.
- Ling, A. R. & Nanji, D. R. (1923). *J. chem. Soc.* p. 2666.
- Manegold, E. & Solf, K. (1931). *Kolloidzshr.* **55**, 273.
- Martin, A. J. P. (1949). *Symp. biochem. Soc.* **3**, 4.
- Meyer, K. H. & Bernfeld, P. (1940). *Helv. chim. acta*, **23**, 875.
- Mould, D. L. (1954). *Biochem. J.* **58**, 593.
- Mould, D. L. & Synge, R. L. M. (1951). *Biochem. J.* **50**, xi.
- Mould, D. L. & Synge, R. L. M. (1952). *Analyst*, **77**, 964.
- Mould, D. L. & Synge, R. L. M. (1954). *Biochem. J.* **58**, 585.
- Pacsu, E. & Mullen, J. W. (1941). *J. Amer. chem. Soc.* **63**, 1168.
- Peat, S., Pirt, S. J. & Whelan, W. J. (1952). *J. chem. Soc.* p. 705.
- Peat, S., Whelan, W. J. & Thomas, G. J. (1952). *J. chem. Soc.* p. 4546.
- Petitpas, T. (1948). *C.R. Acad. Sci., Paris*, **227**, 728.
- Potter, A. L. & Hassid, W. Z. (1948a). *J. Amer. chem. Soc.* **70**, 3488.
- Potter, A. L. & Hassid, W. Z. (1948b). *J. Amer. chem. Soc.* **70**, 3774.
- Potter, A. L. & Hassid, W. Z. (1951). *J. Amer. chem. Soc.* **73**, 593.
- Samec, M. (1940). *Ber. dtsh. chem. Ges.* **73A**, 85.
- Schmid, G. (1951). *Z. Elektrochem.* **55**, 229.
- Schmid, G. (1952). *Z. Elektrochem.* **56**, 181.
- Silberberg, A. & Kuhn, W. (1952). *Nature, Lond.*, **170**, 450.
- Stauffer, R. E. (1950). *Technique of Organic Chemistry* (ed. A. Weissberger), vol. III, p. 317. New York: Interscience.
- Sullivan, R. R. & Hertel, K. L. (1942). *Advanc. Colloid Sci.* **1**, 37.
- Synge, R. L. M. (1949). *Disc. Faraday Soc.* **7**, 164.
- Synge, R. L. M. & Tiselius, A. (1950). *Biochem. J.* **46**, xli.
- Tanret, C. (1914). *C.R. Acad. Sci., Paris*, **158**, 1353.
- Taylor, T. C. & Iddles, H. A. (1926). *Industr. Engng Chem.* **18**, 713.
- Tiselius, A. (1949). *Disc. Faraday Soc.* **7**, 7.
- Tiselius, A. & Flodin, P. (1953). *Advanc. Protein Chem.* **8**, 461.
- Ulmann, M. (1950a). *Naturwissenschaften*, **37**, 309.
- Ulmann, M. (1950b). *Kolloidzshr.* **116**, 10.
- Ulmann, M. (1951a). *Biochem. Z.* **321**, 377.
- Ulmann, M. (1951b). *Kolloidzshr.* **123**, 105.
- Whelan, W. J. & Bailey, J. M. (1954). *Biochem. J.* **58**, 560.
- Whelan, W. J., Bailey, J. M. & Roberts, P. J. P. (1953). *J. chem. Soc.* p. 1293.
- Whistler, R. L. & Johnson, C. (1948). *Cereal Chem.* **25**, 418.
- Yanson, Z. A. (1951). *Věstník Moskov. Univ.* **6**, no. 12. Ser. Fiz.-Mat. i Estestven. Nauk no. 8, 97. Through *Chem. Abstr.* **46**, 8738 (1952).
- Zamenhof, S. & Chargaff, E. (1951). *Nature, Lond.*, **168**, 604.
- Zhukov, I. I. (1943). *Adv. Chem., Moscow*, **12**, 265.
- Zhukov, I. I., Poddubnyi, I. Ya. & Lebedev, A. V. (1948). *Colloid J., Voronezh*, **10**, 423.

The Electrophoretic Mobility and Fractionation of Complexes of Hydrolysis Products of Amylose with Iodine and Potassium Iodide

BY D. L. MOULD AND R. L. M. SYNGE
Rowett Research Institute, Bucksburn, Aberdeenshire

(Received 15 April 1954)

This paper describes some experiments aimed at elucidating the electrophoretic behaviour of polysaccharides related to starch in the presence of iodine and iodide. It has been explained in the previous paper (Mould & Synge, 1954) how these effects came to be observed. The role of iodide in the combination of starch polysaccharides with iodine was studied potentiometrically by Gilbert & Marriott (1948) and by Higginbotham (1949), who give references to earlier work. It has, however, been neglected by most other workers despite the presence of iodide in nearly all of the systems used for studying the starch-iodine reaction. Our experiments also aimed at preparative fractionation of these polysaccharides, and for this purpose the continuous electrophoretic apparatus of Svensson & Brattsten (1949; cf. Grassmann & Hannig, 1950) was used with some modifications in design and operating procedure. Potentiometric and spectro-

photometric studies of the behaviour of the isolated fractions with iodine and iodide are described in the following paper (Mould, 1954).

EXPERIMENTAL

Experiments in agar-agar gels

Agar-agar. As explained in the preceding paper (Mould & Synge, 1954) the velocity of electroendosmosis greatly varied with different specimens of agar-agar although the relative velocities of the zones did not differ. No attempt has been made to relate electroendosmosis with composition or origin of the agar-agar; all the later experiments reported here were done with a batch of strip agar-agar, presumably Japanese, supplied before 1939 by British Drug Houses Ltd.

Apparatus and general procedure. This was according to Consden, Gordon & Martin (1946, Method B). Gels were set in an enclosed trough 3.8 cm. broad and 0.7 cm. deep, the inlaid zone being 1 cm. broad. The agar was dissolved in boiling water at double the desired final concentration and

the solution, when lukewarm, was mixed with an equal volume of solution of buffer constituents, KI and I_2 also at double the desired final concentration. The mixture was immediately poured into the trough. It was important not to have hot agar and iodine together for longer than avoidable, as I_2 concentration was diminished by chemical reaction. When the gel had set, the inlay zone was poured from solution made in the same way but including the specimen for study (dissolved with the agar). Electrophoresis was not started till about 1 hr. after the inlaying, to ensure thorough setting of the gel. Waiting for longer often gave precipitation of polysaccharide-iodine complexes. A potential gradient of 4-5 v/cm. was used. No special cooling was applied and temperatures of 30-40° prevailed during electrophoresis. Electrodes were, unless otherwise stated, perfused with solution having the same composition as the background gel, with agar omitted.

Appearances in a typical experiment. A run was done using (final concentrations) 2% (w/v) agar-agar, 0.04M sodium acetate buffer (pH 4.7), 0.001M- I_2 , 0.00145M-KI and 0.4% (w/v) acid-hydrolysed amylose (Mould & Syngé, 1954) (inlay only). During the time between inlaying and commencing the run, some diffusion occurred at the edges of the inlay zone, the diffused material staining pinker than the purple colour of the body of the zone. Then 5.35v/cm. was applied, and immediately the cathode edge of the zone became orange-yellow while the anode edge became blue. Resolution was then observed into four separate coloured zones, separated by regions not different in colour from the general background in the trough. After 20 hr. from the start of the run these zones were located as follows, measured from the inlay: yellow-brown, 15.0 cm. towards cathode; orange, 8.5 cm. towards cathode; red, 4.0 cm. towards cathode; blue, 10.0 cm. towards anode. In the early stages of the run, the blue zone became broader than the other zones and did not migrate towards the anode. This is explained by the deficit of free iodine and iodide in the original inlay compared with the background gel due to combination with polysaccharide. As electrophoresis proceeded, I_3^- migrating through the gel towards the anode at its final equilibrium concentration saturated successively the yellow-brown, orange and red zones and last the blue zone. The blue zone was initially further depleted by the faster anionic migration of I_3^- , with the result that it broadened, losing anionic mobility. However, on resaturation by I_3^- moving from the cathode side, a compact zone of characteristic mobility was again formed. Another consequence of the initial undersaturation of the polysaccharide zones was that a colourless zone migrated from the inlay fastest towards the anode, having a velocity which we have assumed to be determined by the mobility of I_3^- , the form in which most of the iodine in the background gel is thought to exist. This colourless zone has been used

in determining the mobilities of the different complexes relative to that of I_3^- (see below).

Some of the agar-agar specimens studied, including that used in the experiments now described, gave a faint purple stain when made up in the trough with I_2 -KI as described above. This was presumably due to the presence in the agar-agar of some iodine-staining polysaccharide. In the present case, this background stain gave two well-defined boundaries which migrated at different rates away from the anode end of the gel, leaving behind the slower boundary a region of gel devoid of purple stain.

It was noted that, where there were lumps of imperfectly dispersed agar-agar in the gel, blue-staining material was unable to penetrate the lumps and collected on the side of the lump from which it was migrating irrespective of whether this was towards cathode or anode. A clear streak developed on the opposite side of each lump. Red- and orange-staining materials were not affected by the lumps. These effects are attributed to molecular-sieve action.

Effects of varying conditions: relative mobilities of the zones. Essentially similar results were obtained whether amylose hydrolysates made with HCl or salivary amylase (Mould & Syngé, 1954) were used. Relative intensities of the different zones varied with the extent of the hydrolysis. *N*-2:4-Dinitrophenylethanolamine (DNPE) could be included in the inlay as a marker of electroendosmotic movement of liquid in the gel (cf. James & Syngé, 1951). Its final concentration in the inlay was half-saturation and it did not interfere with the movement of the polysaccharide zones, although the yellow-brown zone partly overlapped the DNPE zone and could not easily be seen. Using 1% (w/v) agar-agar, 0.04M sodium acetate buffer (pH 4.7), 0.0005M- I_2 , 0.00145M-KI and salivary amylase-hydrolysed amylose that had been freed from salt by dialysis in cellophan (0.5 mg./ml. in inlay), the zone centres had the following positions after 6 hr. at approx. 4v/cm.: DNPE, 7.0 cm. towards cathode; orange, 2.0 cm. towards cathode; red, 1.0 cm. towards cathode; blue, 2.7 cm. towards anode; decolorized (I_3^-), 7.7 cm. towards anode. Taking the position of the DNPE zone as giving zero mobility, the anionic mobilities relative to that of I_3^- under the same conditions are thus: blue, 0.66; red, 0.41; orange, 0.34. Doubling the iodine concentration (cf. experiment in previous paragraph) did not markedly affect these relative mobilities. It was not practicable to use still higher I_2 concn., as this led to precipitation of the complexes. It was likewise difficult to do quantitative experiments at lower I_2 concn. on account of the agar- I_2 reaction referred to above, which led to actual I_2 concns. being significantly lower than intended and difficult to control. However, the

general effect of decreasing I_2 concn. while maintaining concn. of KI constant was for the zones to become less intensely coloured and to approach more closely the electroendosmotic flow rate (ascertained using DNPE). The yellow-brown zone was the first to be affected in this way by decreasing I_2 concn. and the blue zone the last. In the absence of I_2 the polysaccharides all migrated at substantially the same rate, corresponding to that of electroendosmotic flow, as revealed by removing the cover from the gel and spraying it with I_2 -KI solution at the end of the run. The same result was obtained whether KI was present or absent during the run. The single zone thus observed had in all cases a somewhat orange-staining leading edge and a blue-purple trailing edge, indicative of adsorption or molecular-sieve effects (see Mould & Synge, 1954). However, increasing the agar-agar concn. in the gel to 8% (w/v), while intensifying this effect somewhat, did not lead to practically useful separations, and agar was accordingly abandoned for the electrokinetic ultrafiltration studies.

The effect of I_2 in conferring anionic mobility on the polysaccharides could be conclusively demonstrated by omitting I_2 from the gel, inlay and electrode perfusion fluids in the experiment described above. After running for a suitable time, I_2 was then added to the cathode perfusion fluid. The boundary of a yellow region then migrated into the gel from the cathode end with the velocity characteristic of I_3^- and when this boundary met the polysaccharide zone advancing towards the cathode the characteristic colour play and resolution commenced, the resulting zones migrating as in the original experiment except that the point of origin had been displaced several cm. towards the cathode.

Preparative fractionation by continuous electrophoresis

The colour of the iodine-iodide complexes being a function of the molecular weight or degree of polymerization (DP) of the straight chain polysaccharides (Swanson, 1948; Bailey, Whelan & Peat, 1950), the striking electrophoretic separation in agar gels appeared to offer a possibility of fractionation of the hydrolysis products of amylose into a molecular-weight series. The portion of gel containing the appropriate fraction might be cut out and the polysaccharide allowed to diffuse out into free solution, but the agar tends to disperse into solution and gives components of low molecular weight which are difficult to separate (cf. Gordon & Reichard, 1951). Even if the method was practicable, the amounts that could be handled would be small. For preparative work continuous electrophoretic fractionation has been carried out in an apparatus similar to that devised by Svensson & Brattsten (1949).

Apparatus (Fig. 1). The apparatus has been enlarged and modified for large-scale separation of a mixture into fractions differing by 10^{-5} cm.²v⁻¹sec.⁻¹ in mobility. The internal dimensions of the Perspex trough were 14 × 20 × 0.8 in., the base being slotted with fifty-one grooves, 0.25 in. in depth. (It was subsequently found advantageous to increase the effective depth of the slots by projecting the sides 0.75 in. into the trough so that when the fractionated material entered the slots it was still within the influence of the electric field.) A short length of stainless-steel tubing (int. diam. 1 mm.) is inserted into each groove, the centres being 0.25 in. apart. The outlet tubes are connected by thin-bore Polythene tubing to individual siphons of adjustable height held by clips to a wooden frame, the siphon outlets dripping into collecting flasks. Sheets of plate glass with 1 in. thick Rubazote sponge-rubber gaskets (Expanded Rubber Co. Ltd., Croydon) form cooling troughs through which tap water circulates on either side of the Perspex trough, the whole arrangement being bolted together between two mild-steel frames. Two thin Perspex walls are inserted in the centre of the trough at the upper edge to form a chamber 0.125 in. in width to permit introduction of the mixture to be analysed. Instead of using powdered glass as the stabilizing medium, an improved regularity of flow and diminished adsorption was obtained by filling the trough with grade 12 ballotini beads (English Glass Co. Ltd., Leicester) 0.2 mm. diam. About 16 lb. of glass beads were required to fill the trough. Blockage of the outlet tubes by the medium was prevented by packing the slots in the base with glass wool. For the elimination of gassing and contamination by electrolysis products the electrode chambers were perfused independently of the stabilizing medium. A platinum wire was mounted in the centre of a 0.5 in. diam. Tufnol (Tufnol Ltd., Manchester) tube, 24 in. long, fitted at one end with inlet and outlet arms. The tube had a 0.25 in. milled slot 17 in. long to within 0.5 in. of the base and was placed inside a cellophan dialysis-tubing sac pulled tight over the milled slot and held in position by cotton at intervals along the length. Both electrodes were inserted into the trough before filling it with the glass beads. The performance of the electrodes was satisfactory, although after about 100 hr. electrophoresis at p.d. 350 v and current 200 mA, the cellophan at the cathode tended to become brittle and had to be replaced. They were perfused with dilute alkali and acid at the anode and cathode respectively, the levels being maintained by a Polythene siphoning drainage tube. The level of the buffer solution in the filled trough was kept constant by a constant-head device, the two halves of the trough being connected by two small siphons.

Fractionation procedure. The trough was flooded with 0.04 M sodium acetate buffer (pH 4.8) containing 0.001 M- I_2 in 0.002 M-KI (final concentrations). This concentration of iodine was sufficiently high for complex formation of the short-chain dextrans with iodine. The cathode was perfused with 0.01 M acetic acid containing double the iodine-iodide concentration in the buffer. The presence of iodine was necessary to maintain the iodine concentration in the trough in the region of the cathode, the migration of the triiodide ion being high compared with the downward velocity of the buffer flow. The anode was perfused rapidly with 0.01 M sodium acetate in order to remove the high concentration of iodine accumulating at this electrode. The rate of flow through each of the drainage tubes of the trough was arranged to be 0.20–0.25 ml./min., the mixture then taking 2.25 hr. to traverse the trough. A p.d. of 350 v was applied

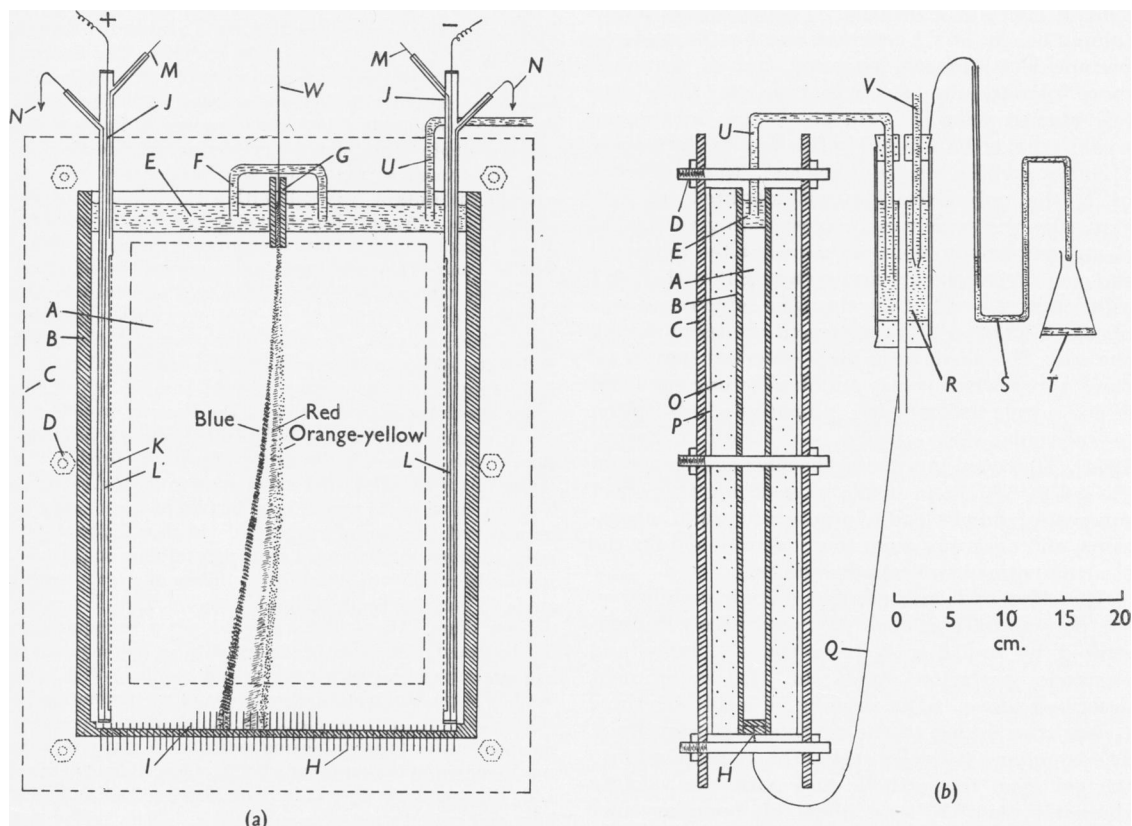

Fig. 1. Preparative electrophoresis cell showing fractionation of hydrolysis products of amylose as complexes with I_2 -KI. (a) Section through cell seen from front (dotted lines indicate steel frame). (b) Section through cell seen from side (electrodes removed). A, glass-bead filling; B, Perspex trough; C, mild-steel frame; D, steel bolts; E, buffer solution; F, siphon connecting two sections of trough; G, mixture inlet chamber; H, stainless-steel outlet tubes; I, grooved base; J, electrodes; K, cellophan; L, platinum-wire electrodes; M, electrode perfusion inlet; N, electrode perfusion drainage siphon; O, Rubazote gaskets for cooling troughs; P, plate glass; Q, Polythene outlet tubes; R, constant-head chamber; S, collecting siphon; T, collecting flask; U, buffer inlet to trough; V, buffer inlet to constant head; W, mixture inlet siphon.

across the electrodes, producing a current of about 250 mA. The temperature at the centre of the glass-bead packing was 18° under these conditions with tap-water cooling through the external troughs.

The scale of the continuous fractionation was largely determined by the concentration of the mixture. It was found that a solution of polysaccharide more concentrated than 1 mg./ml. retrograded, and precipitation of the iodine complex occurred at the high iodine concentration of the trough buffer, thus setting an upper limit to the concentration of the polysaccharide mixture. Under the flow conditions given above the rate of flow of the mixture was 12 ml./hr. so that, allowing for the time taken to flow through the trough, in a continuous 8 hr. electrophoretic run about 60–70 ml. could be fractionated in a day. The process being continuous, longer runs up to 12 hr. have been made. Solutions of salivary α -amylase-hydrolysed amylose taken to various stages of hydrolysis as determined by 'blue value' (B.V.) (Mould & Synge, 1954) were fractionated under

these conditions. The polysaccharide solution was dialysed against distilled water for the removal of strong acid and alkali that would otherwise affect the acidity of the cell buffer in the region of the flowing mixture. Before introduction into the fractionation cell 0.05 M- I_2 , 0.1 M-KI was added to the polysaccharide solution to give the same final concentration of iodine as in the buffer.

In a typical fractionation of an enzymic hydrolysate (B.V. 0.56, the mixture with iodine-iodide then exhibiting a blue-purple coloration), a blue complex immediately separated away from a red complex and by the time the base of the trough was reached a distinct background-coloured gap existed between the two bands. The red complex also separated from a slower-migrating yellow-brown complex, although there was not complete resolution. All the bands migrated electrophoretically towards the anode, the blue complex having the highest apparent mobility. The flow lines of the migrating complexes tended to be slightly curved due to the unbalanced small electro-

endosmotic flow (Svensson & Brattsten, 1949) in the acetate buffer. The width of the bands increased by diffusion during passage through the cell. The blue complex emerged from two outlet tubes separated by a gap of one or two tubes from the red complex also spread out over two outlet tubes. The fractions were collected continuously. The output from intermediate tubes where mixing might have occurred due to slight variations in the width or displacement of the bands during the continuous flow was rejected. This was especially necessary for the satisfactory fractionation of the slower-moving and incompletely resolved red and brown complexes.

In acid-hydrolysed amylose the blue-staining band appeared to be much broader than that obtained from α -amylase hydrolysates of similar B.V. There was also a larger proportion of red and orange-yellow components. In this broad blue-staining band there was evidence of an appreciable spread in mobility across the band as a repeat electrophoretic run of the intermediate mixed blue and red fraction did not give such a wide spread in the blue band, the faster-moving blue components being presumably absent.

Isolation of dextrans. The dextrans, as collected from the outlet tubes of the cell, were present as complexes with I_2 -KI in the presence of sodium acetate buffer and excess I_2 -KI. The iodine was destroyed by titration with slight excess of sodium thiosulphate, using the disappearance of colour of the complex as indicator. The clear solution was then dialysed in cellophan against distilled water for 2 days and finally concentrated *in vacuo* to ca. 50 ml. Last traces of salts were removed by electro dialysis in a four-compartment cell (Theorell & Åkeson, 1942; Syngé, 1951). The pH of the specimen compartment usually remained between 4 and 5 or was so maintained by addition of dilute NH_3 or acetic acid until a constant current of about 5 mA with a p.d. of 230 v was reached. Some of the fractions tended to become cloudy and precipitated at these very low salt concentrations at the completion of electro dialysis. The salt-free solution was then concentrated *in vacuo* to 5 ml. and the dextrin precipitated by addition of 4 vol. ethanol. The precipitate was repeatedly washed with ethanol on the centrifuge, and finally dried *in vacuo* at room temperature yielding a white amorphous powder. The products were stored over P_2O_5 .

A quantitative estimation of the yield of the various electrophoretic fractions in relation to the initial amount of amylose before hydrolysis was not possible as loss of material unavoidably occurred. Mixing of the intermediate collected fractions and their rejection has been mentioned above; abnormalities during an electrophoretic run have on occasion prevented fractionation of part of the original hydrolysate; there may also be incomplete precipitation of the salt-free solutions by ethanol during the extraction procedure and losses in dialysis. The purity of the fractions, i.e. the absence of coloured complexes other than the one collected, was assessed by electrophoretic separation using the agar-gel technique described above. Satisfactory fractions gave a single zone. The difference in movement towards anode and cathode of the blue- and red-staining complexes respectively afforded a sensitive test of contamination. In one run with 42.5 mg. amylose (α -amylase hydrolysis to B.V. 0.28; made to 50 ml. for fractionation) blue and red bands of about equal intensity were seen. On working up the collected fractions 12.2 mg. of 'blue' material, 15.4 mg. of 'red' material, and 2.2 mg. of 'mixed' fractions were isolated. The orange-yellow staining fractions

were not estimated nor were the very short-chain fragments of hydrolysis. The latter are too short to form stable complexes with iodine and are thus uncharged.

Estimation of chain lengths in electrophoretic fractions. The spread of DP in the fractions was estimated by electrokinetic ultrafiltration analysis in collodion membranes (see Mould & Syngé, 1954). After iodine staining of the collodion strip the red material gave a uniform pink coloration, while the front of the zone of the blue material had a slight purplish tinge changing to a uniform blue throughout the rest of the zone. A mixture of the two fractions gave a single zone with no gap in the spread of colour. The purple colour exhibited by the intermediate range, DP 40-50 (cf. Whelan & Bailey, 1954) is not observed during electrophoretic separation in agar gels or in the stabilized glass-bead medium, all the material migrating as a single blue zone. The orange-yellow staining fraction could not be studied by the electrokinetic ultrafiltration procedure owing to the low sensitivity of the iodine staining. A chromatographic separation of the achroic fraction on paper using an amyl alcohol-pyridine-water mixture as solvent (Jeanes, Wise & Dimler, 1951) showed the presence of short-chain dextrans (DP < 10).

DISCUSSION

Electrophoretic fractionation of polysaccharides

Many naturally occurring polysaccharides do not contain ionizing groups and thus, being uncharged in solution, cannot be fractionated by electrophoretic procedures. In fact this electrical neutrality provides a satisfactory basis for the separation of mixtures of charged protein material and carbohydrates (reviewed by Svensson, 1948), and for the isolation of the protein moiety from protein-polysaccharide complexes. There are few examples of the fractionation of uncomplexed polysaccharides. Samec and others (reviewed by Samec & Blinc, 1938; see also Dahl, 1940; Hopkins, Stopher & Dolby, 1940) have fractionated native tuber starches into amylopectin and amylose components by electrodecentration in a vertical field, the phosphate groups esterified to the amylopectin (Posternak, 1935, 1951; Schoch, 1942) causing migration to the anode while the uncharged amylose remains in the supernatant solution. The fractionation is complicated by the presence of charged impurities and the amylose tends to retrograde and precipitate. Phosphate groups are only loosely bound to cereal starches (Posternak, 1935, 1951; Schoch, 1942) and the amylose and amylopectin components are not electrophoretically separable. Saric & Schofield (1946) studied the dissociation of carboxyl and hydroxyl groups of cellulose, starch and other polysaccharides in strongly alkaline solutions and found that in 5N alkali at pH 14.7 it may be regarded as analogous to the dissociation of a weak polybasic acid. The high current density, ohmic heating and increase in diffusion introduce difficulties in the application of this interesting behaviour for the electrophoresis of polysaccharides.

Isherwood (1949), however, reported that various cellulose-type cell-wall polysaccharides migrate with different mobilities under these alkaline conditions and that the formation of one boundary was a strong indication that only one polysaccharide was present. These experiments have been repeated by Colvin, Cook & Adams (1952) using polysaccharide mixtures in *M* alkali with a failure to obtain repeatable electrophoretic patterns. They suggest that the adsorption of the hydroxyl ions on the large neutral molecules would mask any differences in the ionization constants of the hydroxyl groups, and they demonstrated this effect in the separation of sodium alginate from laminarin.

Electrophoretic techniques have been successfully applied to polysaccharides containing ionizing groups such as the polyuronic acids (Säverborn, 1945) and the mucopolysaccharides heparin, chondroitin sulphate, mucoitin sulphate, hyaluronic acid (Wolfrom & Rice, 1947; Gardell, Gordon & Åqvist, 1950). A spread of mobilities with no definite separation, presumably indicating heterogeneity, has been observed with carrageenin (Cook, Rose & Colvin, 1952). The enzymic and acid demethylation of pectin has been compared in terms of the spread of electrophoretic mobilities (Speiser, Copley & Nutting, 1947). The separation of amylose, amylopectin, dextran, glycogen, heparin, hyaluronic acid, levain, yeast mannan, synthetic polyglucose, and starch by paper electrophoresis in barbiturate buffer has been claimed by Greenway, Kent & Whitehouse (1953). For materials other than heparin and hyaluronic acid this is unlikely to be a true electrophoretic separation and is more probably due to a combination of adsorption and electro-osmotic flow which these authors ignored. Amylopectin moved to the cathode with the electro-osmotic streaming as a discrete spot while the amylose was strongly adsorbed by the filter paper and remained at its initial position. The preferential adsorption of amylose by cellulose is a well-established method for the purification of amylopectin. The zone sequence is thus inverted from that in the truly electrophoretic separations of amylose and amylopectin referred to above.

Norberg & French (1950) analysed electrophoretically a mixture of Schardinger α -, β -, and γ -dextrins dissolved in 0.087*M* potassium iodide. No explanation of the difference in mobilities was given (cf. Cramer, 1951). Norberg & French (1950) also described the oxidation of short-chain reducing oligosaccharides to the corresponding acids by alkaline hypiodite, which after conversion into the potassium salts could then be separated electrophoretically.

It would appear that a more extensive application of electrophoretic fractionation techniques to polysaccharides is only possible if attention is

directed towards the formation of charged complexes. The separation of sugar-borate complexes by paper electrophoresis has been developed (Consdon & Stanier, 1952; Jaenicke, 1952; Michl, 1952; Micheel & van de Kamp, 1952) and has been extended for the study of related compounds (Foster, 1952*a, b*; Foster & Stacey, 1953). The mechanism of borate-complex formation in relation to methylated sugars, cyclitols, glucosaminides, glycosides and disaccharides has been discussed (Foster, 1953; see also Woodin, 1952). Fractionation of the electronegative cellulose-cupriethylenediamine complex into two migrating boundaries characteristic of the dissolved cellulose has also been reported (Adams, Karon & Reeves, 1951).

The decrease in electrophoretic mobility of the iodine-iodide complexes of the hydrolysis products of amylose with decreasing chain length has led to possibilities of fractionation according to molecular weight.

Electrophoretic fractionation of hydrolysis products of amylose as iodine-iodide complexes

The electrophoretic fractionation separates the hydrolysate into (1) a scarcely staining zone DP < 10, (2) an orange-staining zone DP 10–25, (3) a red-staining zone DP 25–40, and (4) a blue-staining zone DP 40–130, the upper limit depending on the degree of hydrolysis. The zones are separated by gaps in which polysaccharide is absent.

A decrease in the longest chain length in the hydrolysate with increasing hydrolysis is observed (Table 1). A series of separations of α -amylase

Table 1. *Estimated chain length in electrophoretic fractions from amylose hydrolysed with α -amylase*

DP was estimated by electrokinetic ultrafiltration (Mould & Synge, 1954).

Degree of hydrolysis (b.v.)	Fraction	DP
0.56	Red	25–40
	Blue	40–120
0.42	Red	27–42
	Blue	40–90

Table 2. *Change in proportion of blue and red material during α -amylase hydrolysis of amylose*

Yields reported are from preparative electrophoretic runs on various hydrolysates.

Degree of hydrolysis (b.v.)	Blue material (mg.)	Red material (mg.)	Blue/red
0.1	2.4	4.0	0.6
0.25	44	66	0.66
0.28	12.2	15.4	0.79
0.34	50	37	1.35
0.39	79	34	2.3
0.45	81	44	1.84
0.57	55	16	3.3

hydrolysates of decreasing B.V. has been made and the relative amounts of blue- and red-staining material estimated (Table 2). As would be expected, the ratio of blue material to red material falls with increasing degree of hydrolysis, although it is interesting to observe that even at a low B.V. (0.2), where the iodine-staining colour of the hydrolysate is predominantly red, there is still a comparatively high amount of the blue material still present. The greater spread of chain lengths observed in the acid hydrolysate would be expected as a result of a more random breakage of the polyglucosidic chains during acid hydrolysis compared with α -amylase hydrolysis (cf. Meyer & Gonon, 1951).

Structure of the iodine-iodide complex and electrophoretic mobility

In a consideration of the formation of a charged complex of the dextrin with iodine-iodide solution the conception of a helical structure of the polysaccharide molecule with an inner core of resonating iodine atoms (Hanes, 1937; Freudenberg, Schaaf, Dumpert & Ploetz, 1939; Bear, 1942; Rundle & Baldwin, 1943; Baldwin, Bear & Rundle, 1944; Stein & Rundle, 1948) is extended to include iodide ions as supplying the resonating electrons (Gilbert & Marriott, 1948).

A limited study (Mould, 1954) of the potentiometric titration of the electrophoretically separated fractions with iodine has been made using the method of Gilbert & Marriott (1948) (cf. Bates, French & Rundle, 1943; Dvornch, Yearian & Whistler, 1950). The characteristic blue coloration increases in intensity during the formation of the complex $3I_2-yI^-$. In the case of the red-staining material the complex $2I_2-y'I^-$ is formed. The evaluation of y and y' has not been attempted owing to the lengthy experimental work involved.

The ultraviolet and visible absorption spectra of the fractions when in complex formation with iodine have also been examined (Mould, 1954), and it has been shown that in the longer helices giving a blue coloration there is probably a strong polarizing effect of the I^- ions on the I_2 molecules in the chain, with a gradual extension in the average separation between the iodine atoms in the core as the length of the helix increases. With decreasing chain length and shift of the absorption peak in the visible range to shorter wavelengths, there is a tendency towards the formation of an I_3^- -type complex.

Without further extensive potentiometric studies of the complex structure, which may be complicated by surface adsorption of iodine (Mould, 1954), one can only speculate as to the probable nature of the complex. The supposition is made here that the

colour and mobility of the blue migrating complexes are determined by the presence of a $(3I_2-2I^-)_n$ grouping (similar to the structure of an amylose-iodine-iodide complex reported by Gilbert & Marriott (1948)) and that the colour and mobility of the red migrating complex are determined by an $(I_3^-)_n$ grouping. A length along the helix of 8 Å per single turn of 6 glucose units is taken from the data of Dombrow & Beckmann (1947). The ratio of the length of the iodine-iodide core to the length of the helix increases with DP so that the net charge and amount of iodine absorbed will increase rapidly with DP. A linear array of three $(3I_2-2I^-)$ groups may exist in a helix of DP 72, length 96 Å, giving a charge/mass ratio 4.1×10^{-4} . The average separation between the iodine atoms in such a linear resonating array is 3.1 Å (Hach & Rundle, 1951; Cramer, 1951; Cramer & Herbst, 1952), although such stable conditions are probably not attained in the present case. The length of the $9I_2-6I^-$ complex considered would therefore be <70 Å. Allowing for a decrease in diffusion coefficient with increasing DP in relation to the increasing net charge, it is conceivable that the electrophoretic mobilities may only extend over a narrow range. In the red-staining dextrans a loosely bonded linear array of two I_3^- ions may exist in a helix of DP 36, length 48 Å, giving a charge/mass ratio 3.0×10^{-4} . Assuming a length 5.92 Å for the I_3^- ion (Mooney, 1935) and 3.0 Å for the separation between the two ions, the distance between the extreme atoms of the $2I_2-2I^-$ complex is 14.8 Å. The mobility of a short dextrin complex is reduced therefore by virtue of the very short iodine-iodide core that can be established.

Whether or not this speculation proves correct the apparently abrupt change in the mobility and colour of the iodine-iodide complex over a narrow range of chain lengths at approx. DP 40 is striking. Failure to isolate material of intermediate chain length giving a purple stain in free solution raises the question of whether the purple stain (observed with partial hydrolysis of amylose and with amylopectin, etc.) corresponds to a true complex or a mixture of red and blue complexes arising from the competition of the polysaccharides for iodine and iodide ions. The purple coloration of partially hydrolysed amylose could obviously arise from a mixture of red and blue complexes and it has also been shown (Whelan & Bailey, 1954) that in an enzyme-synthesized polyglucose of average DP 45 there would be a statistical spreading of the chain lengths sufficient for the formation of both red and blue complexes. A definite conclusion as to the colour of the complex over a narrow range of DP could be made by refinement of the electrokinetic ultrafiltration procedure (Mould & Synge, 1954) to give material of narrow DP range. It is suggested that in this critical range around DP 40, there may

be a sudden change in the type of complex dependent on the formation of a longer iodine-iodide core, so that, according to the availability of iodine, the dextrin may form either a red or blue complex.

It was not possible to derive values for the mobility of the complexes from their movements in the preparative cell. Mobilities could be calculated from the agar-gel experiments but were only strictly applicable for electrophoretic movement through the gel medium itself. There was also no control of temperature during the separation. For these reasons only the relative mobilities of the various complexes have been considered.

The potentiometric titration of the fractionated dextrans with iodine-iodide solution (Mould, 1954) has shown that the minimum concentrations of iodine required for saturation in 10^{-3} M-KI are 1.0×10^{-5} M, 3.2×10^{-5} M, and 15.0×10^{-5} M respectively for the blue, red and orange complexes. During fractionation in the preparative cell the complexes were therefore under saturation conditions, and increasing the iodine concentration above 0.0005 M in the agar-gel experiments did not in fact affect the relative mobility of the complexes. However, as observed in these experiments, progressively decreasing the iodine concentration will obviously prevent the formation of the yellow-brown complex first and the blue complex last. Gilbert & Marriott (1948), in their potentiometric studies of amylose-iodine complexes, found that the blue colour of the amylose complex developed when the ion ($3I_3-2I^-$) was present but at lower iodine concentrations a small quantity of another ion suggested as ($2I_3-I^-$) is formed. The presence of ions of lesser charge in low iodine concentration could also be inferred from the potentiometric titration curves of the fractionated dextrans considered here (Mould, 1954). The broadening of the mobilities and change in direction of migration of the blue complex during the initial stages of electrophoresis in agar gels provides further evidence for the existence of these unsaturated complexes.

SUMMARY

1. Partial hydrolysates of amylose are resolved into four separate coloured zones by zone electrophoresis in agar jelly in the presence of iodine-iodide. The effects on the resolution of varying the iodine-iodide concentration are described. *N*-2:4-Dinitrophenylethanolamine was used as a marker of electroendosmotic movement.

2. Continuous electrophoretic fractionation of α -amylase-hydrolysed amylose in the presence of iodine-iodide has been carried out in an apparatus similar to that of Svensson & Brattsten (1949).

3. Four fractions have been isolated in a salt-free state, viz. material from (a) a non-staining zone

having degree of polymerization (DP) < 10; (b) an orange-staining zone DP 19-25; (c) a red-staining zone DP 25-40; (d) a blue-staining zone DP 40-130 (the upper limit depending on the degree of hydrolysis).

4. With improvement of technique fraction (d) could probably be further fractionated. The method is applicable to the study of enzymic breakdown of high-molecular starch-like polysaccharides and possibly to the fractionation of polydisperse substances such as amylopectin or glycogen.

5. Possible structures of the various iodine-iodide-dextrin complexes are discussed, and it is suggested that there is a sudden change in the type of complex formed at DP ca. 40. The purple-staining complexes formed by dextrans in the range DP 40-50 may be a mixture of red- and blue-staining complexes.

We are grateful to Dr G. A. Gilbert, Professor A. Tiselius and Dr W. J. Whelan for critical discussions. We wish to thank Messrs A. Dawson and J. Wood for technical assistance.

REFERENCES

- Adams, M. E., Karon, M. L. & Reeves, R. E. (1951). *J. Amer. chem. Soc.* **73**, 2350.
 Bailey, J. M., Whelan, W. J. & Peat, S. (1950). *J. chem. Soc.* p. 3692.
 Baldwin, R. R., Bear, R. S. & Rundle, R. E. (1944). *J. Amer. chem. Soc.* **66**, 111.
 Bates, F. L., French, D. & Rundle, R. E. (1943). *J. Amer. chem. Soc.* **65**, 142.
 Bear, R. S. (1942). *J. Amer. chem. Soc.* **64**, 1388.
 Colvin, J. R., Cook, W. H. & Adams, G. A. (1952). *Canad. J. Chem.* **30**, 603.
 Consden, R., Gordon, A. H. & Martin, A. J. P. (1946). *Biochem. J.* **40**, 33.
 Consden, R. & Stanier, W. M. (1952). *Nature, Lond.*, **169**, 783.
 Cook, W. H., Rose, R. C. & Colvin, J. R. (1952). *Biochim. biophys. Acta*, **3**, 595.
 Cramer, F. (1951). *Chem. Ber.* **84**, 855.
 Cramer, F. & Herbst, W. (1952). *Naturwissenschaften*, **39**, 256.
 Dahl, O. (1940). *Kolloidzshr.* **92**, 70.
 Dombrow, B. A. & Beckmann, C. O. (1947). *J. phys. Chem.* **51**, 107.
 Dvornch, W., Yearian, H. J. & Whistler, R. L. (1950). *J. Amer. chem. Soc.* **72**, 1748.
 Foster, A. B. (1952a). *Chem. & Ind.* p. 828.
 Foster, A. B. (1952b). *Chem. & Ind.* p. 1050.
 Foster, A. B. (1953). *J. chem. Soc.* p. 982.
 Foster, A. B. & Stacey, M. (1953). *Chem. & Ind.* p. 279.
 Freudenberg, K., Schaaf, E., Dumpert, G. & Ploetz, T. (1939). *Naturwissenschaften*, **27**, 850.
 Gardell, S., Gordon, A. H. & Åqvist, S. (1950). *Acta chem. scand.* **4**, 907.
 Gilbert, G. A. & Marriott, J. V. R. (1948). *Trans. Faraday Soc.* **44**, 84.
 Gordon, A. H. & Reichard, P. (1951). *Biochem. J.* **48**, 569.

- Grassmann, W. & Hannig, K. (1950). *Z. angew. Chem.* **62**, 170.
- Greenway, R. M., Kent, P. W. & Whitehouse, M. W. (1953). *Research, Lond.*, **6**, 6S.
- Hach, R. J. & Rundle, R. E. (1951). *J. Amer. chem. Soc.* **73**, 4321.
- Hanes, C. S. (1937). *New Phytol.* **36**, 189.
- Higginbotham, R. S. (1949). *Shirley Inst. Mem.* **23**, 159, 171.
- Hopkins, R. H., Stopher, E. G. & Dolby, D. E. (1940). *J. Inst. Brew.* **46**, 426.
- Isherwood, F. A. (1949). *Proc. 1st Int. Congr. Biochem. Cambridge. Abstract no. 339/11*, p. 515.
- Jaenicke, L. (1952). *Naturwissenschaften*, **39**, 86.
- James, A. T. & Syngé, R. L. M. (1951). *Biochem. J.* **50**, 109.
- Jeanes, A., Wise, C. F. & Dimler, R. J. (1951). *Analyt. Chem.* **23**, 415.
- Meyer, K. H. & Gonon, W. F. (1951). *Helv. chim. acta*, **34**, 294.
- Micheel, F. & Kamp, F. P. van de (1952). *Angew. Chem.* **64**, 607.
- Michl, H. (1952). *Mh. Chem.* **83**, 737.
- Mooney, R. C. L. (1935). *Z. Kristallogr.* **90**, 143.
- Mould, D. L. (1954). *Biochem. J.* **53**, 593.
- Mould, D. L. & Syngé, R. L. M. (1954). *Biochem. J.* **58**, 571.
- Norberg, E. & French, D. (1950). *J. Amer. chem. Soc.* **72**, 1202.
- Posternak, T. (1935). *Helv. Chim. acta.* **18**, 1351.
- Posternak, T. (1951). *J. biol. Chem.* **188**, 317.
- Rundle, R. E. & Baldwin, R. R. (1943). *J. Amer. chem. Soc.* **65**, 554.
- Samec, M. & Blinc, M. (1938). *Kolloidbeihfte.* **47**, 371.
- Saric, S. P. & Schofield, R. K. (1946). *Proc. Roy. Soc. A*, **185**, 431.
- Säverborn, S. (1945). *Acid polyuronides*. Uppsala: Almqvist & Wiksells Boktryckeri AB. Through *Chem. Abstr.* (1947), **41**, 396c.
- Schoch, T. J. (1942). *J. Amer. chem. Soc.* **64**, 2957.
- Speiser, R., Copley, M. J. & Nutting, G. C. (1947). *J. phys. Chem.* **51**, 117.
- Stein, R. S. & Rundle, R. E. (1948). *J. chem. Phys.* **16**, 195.
- Svensson, H. (1948). *Advanc. Protein Chem.* **4**, 251.
- Svensson, H. & Brattsten, I. (1949). *Ark. Kemi*, **1**, 401.
- Swanson, M. A. (1948). *J. biol. Chem.* **172**, 825.
- Syngé, R. L. M. (1951). *Biochem. J.* **49**, 642.
- Theorell, H. & Åkeson, Å. (1942). *Ark. Kemi Min. Geol.* **16A**, no. 8.
- Whelan, W. J. & Bailey, J. M. (1954). *Biochem. J.* **58**, 560.
- Wolfrom, M. L. & Rice, F. A. H. (1947). *J. Amer. chem. Soc.* **69**, 2918.
- Woodin, A. M. (1952). *Biochem. J.* **51**, 319.

Potentiometric and Spectrophotometric Studies of Complexes of Hydrolysis Products of Amylose with Iodine and Potassium Iodide

By D. L. MOULD

The Rowett Research Institute, Bucksburn, Aberdeenshire

(Received 15 April 1954)

The formation of coloured complexes in starch-iodine-iodide solutions is of interest in relation to the structure of starch components and also as to the nature of the molecular linkage and optical absorption in iodine-iodide chains. The establishment of the helical structure of the amylose fraction of starch (Hanes, 1937; Freudenberg, Schaaf, Dumpert & Ploetz, 1939; Bear, 1942; Rundle & Baldwin, 1943; Spark, 1952) and the potentiometric titration of amylose with iodine (Bates, French & Rundle, 1943; Gilbert & Marriott, 1948; Higginbotham, 1949) have led to the idea of a collinear core of iodine and iodide molecules arranged end-to-end inside the amylose helix. Recent advances in the enzymic synthesis of a homologous series of straight-chain polysaccharides consisting of glucose residues in α -1:4 linkage (Cori & Cori, 1939; Whelan & Bailey, 1954) have opened up a possible extension of the potentiometric and other methods of investigation for the study of the changes in the iodine-iodide structure and its relation to the change of colour and optical ab-

sorption spectra of the complex (Bailey, Whelan & Peat, 1950).

The potentiometric titration of amylose (Bates *et al.* 1943) and of fractionated preparations of hydrolysed amylose (Dvornch, Yearian & Whistler, 1950) with iodine have shown that the bulk of iodine in the complex is absorbed at constant activity, followed by a slow increase, attributed to surface absorption, with the continual increase in the concentration of free iodine as the titration proceeds. For a straight-chain amylose less than *ca.* 100 glucose units it is not possible to distinguish clearly between surface absorption and complex formation. (The order of chain length stated by Dvornch *et al.* is based on earlier possibly inaccurate spectrophotometric estimates of chain length by Swanson, 1948: cf. Bailey *et al.*, 1950; Bailey, 1952.) The iodine activity required for complex formation is a function of the molecular weight of the amylose, being lower for samples of higher molecular weight. Long helices tend to be filled before short ones can absorb appreciably, the stability of the iodine-