

A direct relation between the amniotic and allantoic fluids across the placental membranes seems improbable from the present results. Therefore, if the amniotic fluid is absorbed by the foetus, the foetal digestive tract and kidney would be the main agents determining the quantity and composition of the allantoic fluid. Hence the present 'passive' study of the composition of the two fluids gives us the following picture of their origin and interrelation: the amniotic fluid arises as a transudate of the maternal serum and the allantoic fluid comes from the amniotic fluid by the intervention of the foetus. This view could be tested further by a combination of the more active experimental approach of some of the earlier workers with present-day techniques, and would need to be correlated with both physiological and anatomical evidence.

SUMMARY

1. The composition, mainly ionic, of a series of allantoic and amniotic fluids obtained, at five regular intervals during gestation, from ewes fed during pregnancy to maintain their weight to the end of pregnancy, has been studied.

2. As gestation proceeded the allantoic fluid showed an increase in non-protein nitrogen and other organic matter, potassium and magnesium, and decrease in chloride and inorganic phosphorus. The values for calcium were higher in the middle than at the beginning or end of gestation.

3. The amniotic fluid was more constant in composition; it had a lower specific gravity and organic matter, non-protein and protein nitrogen and magnesium contents, and higher sodium and chloride contents than the allantoic fluid. Potassium, calcium and inorganic phosphorus contents were within the ranges for allantoic fluid.

4. Comparison of these results, with data available for the composition of sheep serum and foetal urine, suggest that the amniotic fluid is in Donnan equilibrium with the maternal serum, and that the chemical differences between the amniotic and allantoic fluids are due to the intervention of the digestive tract and kidney of the foetus.

I am indebted to Dr L. R. Wallace, Animal Research Station, University of Cambridge, for the supply of foetal fluids and for permission to include in Table I some of his data about the fluids.

REFERENCES

- Clark, E. P. & Collip, J. B. (1925). *J. biol. Chem.* **63**, 461.
 Denis, W. (1922). *J. biol. Chem.* **52**, 411.
 Doderlein, A. (1890). *Arch. Gynaek.* **37**, 141.
 Dukes, H. H. (1943). *Physiology of Domestic Animals*, 5th ed., p. 45. Ithaca, N.Y.: Comstock.
 Fiske, C. H. & Subbarow, Y. (1925). *J. biol. Chem.* **66**, 375.
 Flexner, L. A. & Gellhorn, A. (1942). *Amer. J. Physiol.* **136**, 757.
 Jacque, L. (1902). *Mém. cour. Acad. R. Belg.* **63**, 3.
 Kramer, B. & Gittleman, I. (1924). *J. biol. Chem.* **62**, 353.
 Kramer, B. & Tisdall, F. F. (1921). *J. biol. Chem.* **46**, 339.
 Malan, A. I., Malan, A. P. & Curson, H. H. (1937). *Onderstepoort J. vet. Sci.* **9**, 205.
 Paton, D. N., Watson, B. P. & Kerr, J. (1907). *Trans. roy. Soc. Edinb.* **46**, 71.
 Peters, J. P. & Van Slyke, D. D. (1932). *Quantitative Clinical Chemistry*, **2**, 70. London: Baillière, Tindall and Cox.
 Sendroy, J. Jr. (1937). *J. biol. Chem.* **120**, 405.
 Shearer, G. D. & Stewart, J. (1931). *Rep. Inst. Anim. Path. Univ. Camb.* **2**, 121.
 Wallace, L. R. (1948). *J. agric. Sci.* **38**, 243.

A Photoelectric Flame Photometer

By W. R. DOMINGO AND W. KLYNE

Laboratory of Soil Science, North-east Polder Reclamation Works, Kampen, Netherlands and the Postgraduate Medical School, London, W. 12

(Received 29 April 1949)

The flame photometer is an instrument for determining the concentrations of certain metals in solution by measuring the intensity of the light emitted by them when the solution is sprayed under controlled conditions into a non-luminous flame. Lundegårdh (1929-34) developed an apparatus in which cations in solution were sprayed into an air-acetylene flame, and the spectra produced photographed and compared with similar spectra from

standard solutions. More recently several workers (for literature, see Barnes, Richardson, Berry & Hood, 1945; Boon, 1945) have designed instruments in which the light from the flame is passed through optical filters on to a photosensitive element (selenium cell or phototube) and the current so produced is measured. Such instruments may be bought in the United States (from the Perkin-Elmer Corporation, Glenbrook, Connecticut, or the National

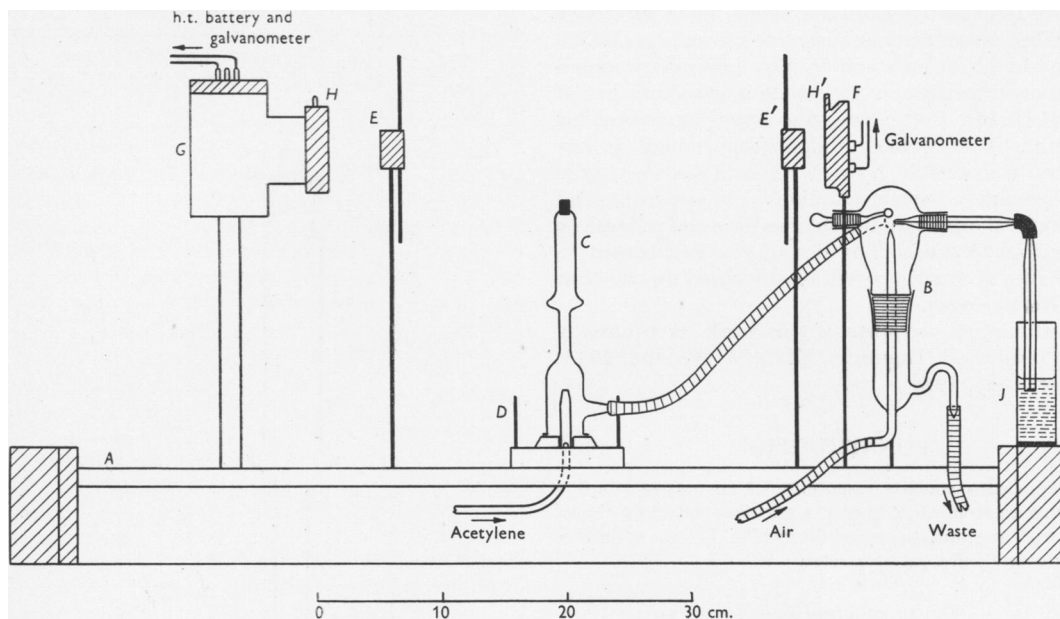

Fig. 1. Flame photometer; general arrangement, excluding chimney, gas cylinders, manometers and galvanometer. *A*, optical bench; *B*, atomizer; *C*, burner; *D*, support for chimney; *E*, *E'*, iris diaphragms; *F*, selenium cell in holder; *G*, phototube in holder; *H*, *H'*, optical filters; *J*, solution under test.

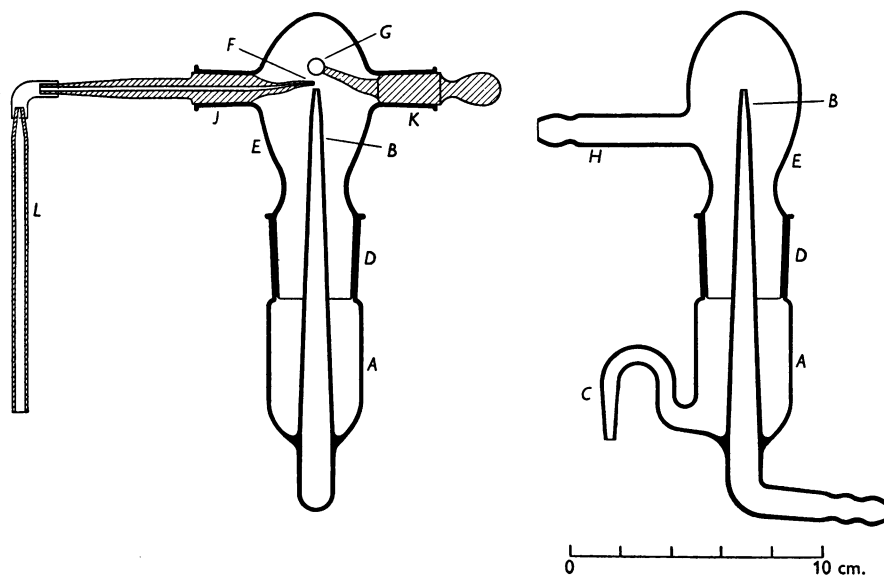

Fig. 2. Atomizer (two vertical cross-sections at right angles). *A*, lower part carrying air inlet (*B*) and drain for waste (*C*). *A* is joined by the ground glass joint (*D*) to the upper part *E*, which carries the solution inlet (*F*), the baffle plate (*G*) and the outlet to the burner (*H*). *F* and *G* are mounted on ground glass joints (*J*, *K*). *F* is joined by a piece of narrow rubber tubing to the vertical tube *L* which dips into the solution to be analysed.

Technical Laboratories, South Pasadena, California), but are difficult to obtain in Europe. The instrument described below can be constructed from parts which are available from stock by any laboratory which has a good mechanic. Its design is based on that of Boon (1945), but, since the latter described his instrument only in a dissertation which is not generally accessible, it was thought desirable to give this account of the construction of our apparatus and its use for the determination of sodium and potassium in biological fluids. The use of the instrument in agricultural chemistry will be described by one of us (W. R. D.) elsewhere.

Preliminary accounts of this work have already been published (Domingo, Klyne & Weedon, 1948; Klyne, 1948, 1949).

CONSTRUCTION

The apparatus consists essentially of an optical bench—carrying an atomizer, a burner, a selenium cell and a phototube with appropriate optical filters (Fig. 1)—gas cylinders, manometers and a galvanometer.

Gas supply and regulation

Air and acetylene are supplied from cylinders carrying two-stage regulators (British Oxygen Co. Ltd.), which regulate the pressures to 10 lb./sq.in. for air and 6 lb./sq.in. for acetylene. Each gas is carried from the cylinder through reinforced rubber tubing (5 mm. internal diameter) to a glass tap (1.5 mm. bore), which is rotated by a slow-motion dial to adjust the gas flow more precisely. (The slow-motion dials are of the type frequently used in radio equipment.) Beyond the glass tap each gas passes to a T-piece, one arm of which is connected to the apparatus whilst the other is connected to a U-tube manometer (height 55 cm.). An air pressure of 40 cm. mercury and an acetylene pressure of 38 cm. water have been found convenient with this apparatus; these pressures are dependent on the size of the air and solution inlets. The glass taps, slow-motion dials and manometers are all conveniently mounted on a vertical board beside the optical bench.

Atomizer

The all-glass atomizer (Fig. 2) resembles that of Rauterberg & Knippenberg (1940), and can be obtained from the Laboratory Glassblowers Co., 63 Lowlands Road, Harrow, Middlesex. Air flowing up the tube *B* past the tip of the solution inlet *F* creates sufficient suction to draw solution up the tube *L* and along *F* and then blow it into a fine spray. The larger particles of this spray strike the plate *G* and are retained; the finer particles pass through *H* and thence to the burner.

Burner

The glass burner (Fig. 3) resembles that of Lundegårdh (1929–34; cf. McClelland & Whalley, 1941; Mitchell, 1948) and can be obtained from the Laboratory Glassblowers Co., Harrow. The dimensions of the atomizer and burner only are critical; the dimensions of the remaining parts of the apparatus can probably be varied somewhat without greatly

affecting its performance. The burner is held in position by the metal support (Fig. 4) and is surrounded by a metal chimney (Fig. 5) carrying two holes for a condenser lens and an inspection hole. The centre line of the lens holes is 3.5 cm. above the tip of the burner, and 23.5 cm. above the base of the burner.

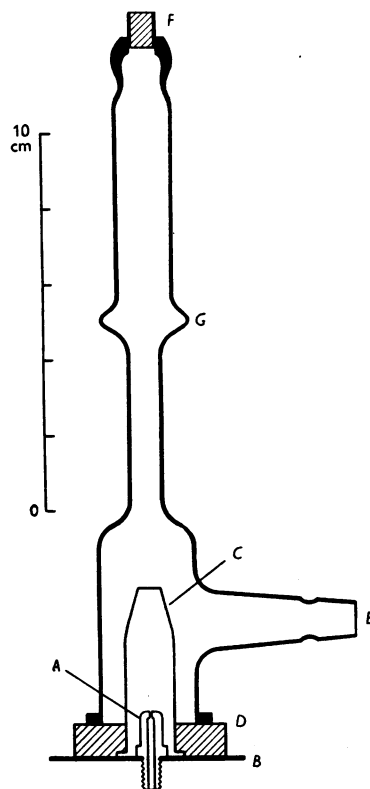

Fig. 3. Burner (vertical section). *A*, acetylene inlet (0.5 mm. diameter) screwed into base plate *B*; *C*, inner cone fitting into rubber washer (*D*); *E*, inlet for air carrying spray from atomizer; *F*, platinum tip; *G*, wider part of tube to fit into support.

Optical and electrical system

The base of the burner and chimney is mounted on an optical bench, one end of which is used for Na determinations and the other for K determinations.

Determination of sodium (Fig. 6). The light from the outer cone of the flame *C* passes through a plano-convex lens *E*, the iris diaphragm *F* and the optical filters *H* on to a selenium cell *J* (type A, 25 mm. diameter, Evans Electro-selenium Ltd., Harlow, Essex). The Chance orange filter (no. OY 1) with an Ilford blue filter (no. 803) has proved suitable for isolating the Na *D* lines (589 and 590 μ). The current from the selenium cell is fed directly on to a galvanometer; a Tinsley SS5 box galvanometer (deflexion 85 mm./ μ a.) is convenient. We have used a reciprocal logarithmic scale of the type commonly employed on photoelectric colorimeters (cf. King, 1947) graduated in terms of $y = 100 \log (100/x)$.

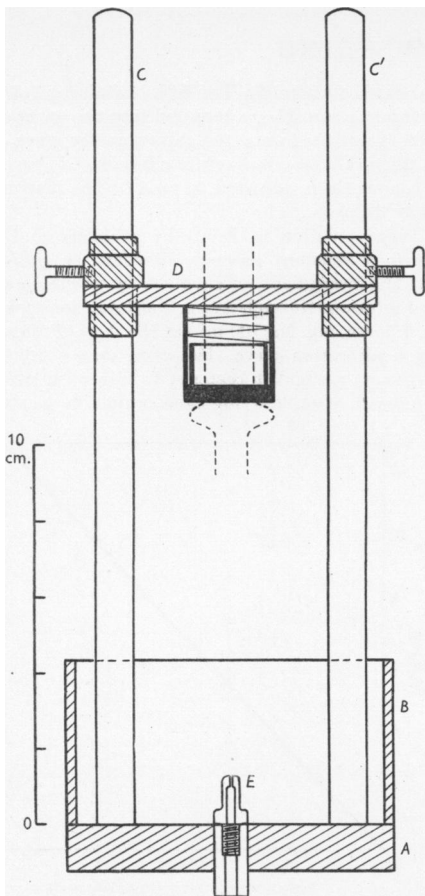

Fig. 4. Support for burner (vertical section). *A*, base plate; *B*, support for chimney with seven air holes (25 mm. diameter); *C*, *C'*, supports; *D*, spring-loaded collar fitting on to wider part of burner (shown in dotted lines); *E*, acetylene inlet.

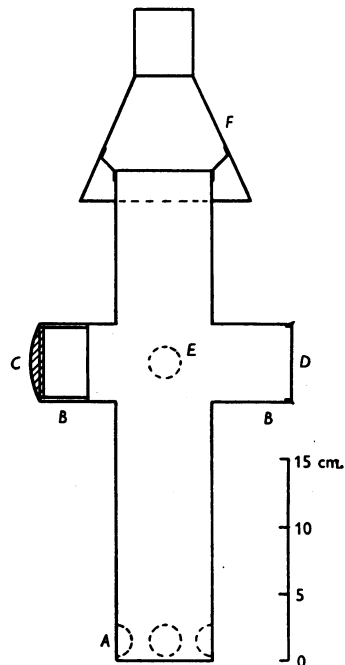

Fig. 5. Chimney (vertical section). *A*, base with holes (each 25 mm. in diameter) to admit air (fits into support Fig. 4 *B*); *B*, *B*, holes for lens; *C*, plano-convex lens (focal length 9 cm.) in sliding tube; *D*, metal plate to cover hole not used for lens; *E*, shows the position of the inspection hole on the front of the chimney; *F*, cowl.

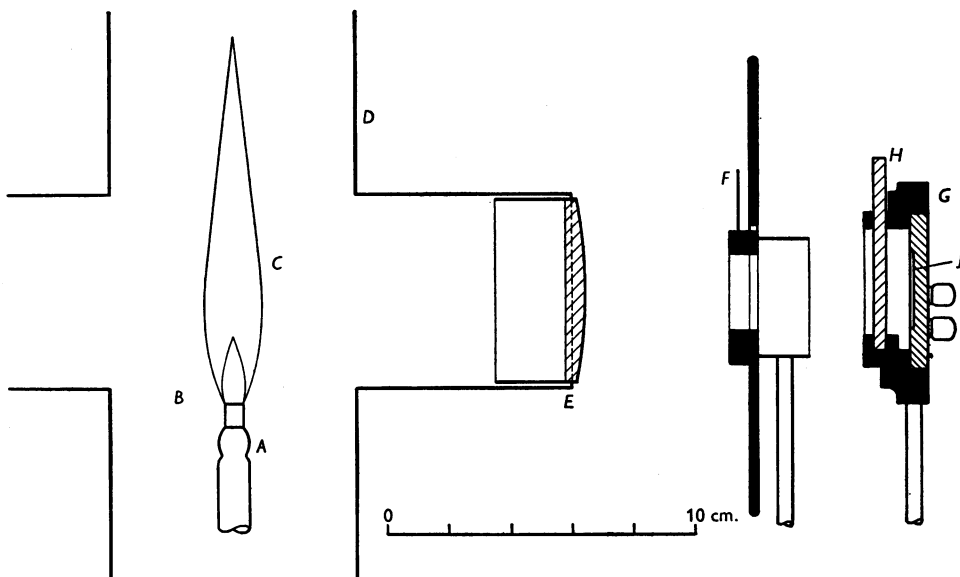

Fig. 6. Optical system for determination of sodium. *A*, burner; *B*, inner cone; *C*, outer cone of flame; *D*, chimney; *E*, plano-convex lens (focal length 9 cm.); *F*, iris diaphragm (maximum aperture, 25 mm.; mounted in shield); *G*, holder for optical filters *H* and selenium cell *J*.

Determination of potassium. The burner and chimney are arranged as for the determination of Na, except that the plano-convex lens is in the left-hand end of the chimney. An iris diaphragm is mounted 15.5 cm. from the centre line of the burner, and a photocell and filter (Fig. 7) are mounted with the centre line of the cell 25 cm. from that of the burner. A gas-filled caesium-cathode cell (Type GS18, Cinema Television Ltd., Crystal Palace, London, S.E.) and an Ilford spectrum deep red filter (no. 609) are suitable for the

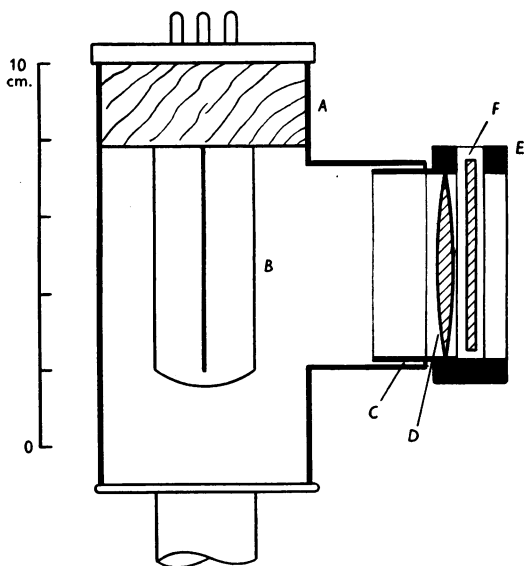

Fig. 7. Photocell and filter for determination of potassium. *A*, holder for photocell *B*; *C*, tube sliding into the front aperture of *A* carrying a biconvex lens *D* (focal length 6 cm.) and a holder *E* which supports the optical filter *F*.

measurement of the 766 and 770 $m\mu$. K lines. A potential of 72 V. is applied to the cell from a dry battery, and the photoelectric current is measured with the same galvanometer as for Na. A resistor and capacitor in parallel ($1M\Omega$, $0.5\mu F.$, time constant about 1 sec.) are placed in the h.t. lead from the battery to damp variations in h.t. current.

OPERATION

The instrument is assembled without its chimney, and the air is then turned on and adjusted to 40 cm. pressure. Water is placed under the inlet tube and this tube, the air inlet and the baffle plate are adjusted until a maximum spray is produced. The acetylene is then turned on, and the burner is lit. The flame should resemble a non-luminous Bunsen flame and should burn quietly. If flashes of white light appear in the flame, more air is needed. If the flame burns noisily, less air is needed. The behaviour of each burner must be studied individually; careful adjustment of the flame is necessary, since an unsatisfactory flame gives very erratic results.

The chimney is then put in place, and the appropriate photocell connected to the galvanometer. Further adjustment of gas and air pressures may be desirable to steady the flame so as to obtain a steady galvanometer reading.

A standard solution (NaCl or KCl, containing 2–4 mg. Na or K/100 ml. is suitable) is then fed into the atomizer, and the latter is adjusted until the galvanometer gives a maximum reading. The standard solution is replaced by water and the galvanometer is adjusted to read 0. The instrument is now ready for use.

If it were possible to keep the atomizer and burner working in a constant manner, it would be sufficient to calibrate the instrument for each run by passing a series of standard solutions through it (e.g. NaCl solutions containing 0.5, 1.0, 1.5, etc. mg. Na/100 ml.) at the start of the run, and drawing a calibration curve. However, since conditions are liable to vary, we find it best not to rely on a calibration curve; instead, after spraying each sample for analysis, we

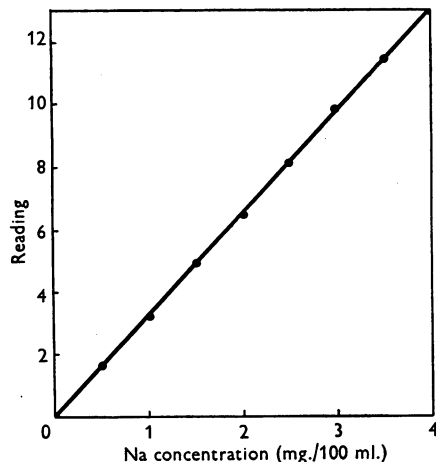

Fig. 8. Flame photometer readings for sodium. Standard curve obtained with pure NaCl solutions. (All readings in Figs. 8–13 are galvanometer readings on the reciprocal logarithmic scale described on p. 402).

spray two standards, one of higher and one of lower concentration, and obtain the result by interpolation. The galvanometer readings on a logarithmic scale are directly proportional to the Na or K concentration, at least over short ranges (Figs. 8 and 13).

The instrument takes in solution at the rate of about 10 ml./min., and a sample with the two appropriate standards can be sprayed twice in 3 min. The instrument responds almost immediately to changes in the solution fed, and it is not necessary to wash through with water between each pair of solutions.

When a series of samples has been sprayed, the instrument is cleaned by thorough spraying with water, and then ethanol is sprayed. While the ethanol is burning at the flame, the acetylene is turned off and then air is drawn through for about a minute. The use of ethanol prevents the flame from back firing when the acetylene is turned off.

RESULTS

Solutions of pure sodium and potassium salts

Over the ranges which are required for sodium and potassium determinations on body fluids (0–5 mg./100 ml.) the relationship between galvano-

meter readings and sodium or potassium concentrations is either linear or so near to linear that simple interpolation between two standards is possible. Specimen results are shown in Figs. 8 and 13.

Interference by anions. In view of the results obtained by other workers on the effect of anions on flame-photometer readings (Barnes *et al.* 1945; Crismon, 1948; Shapiro & Hoagland, 1948) solutions

(1) Potassium increases slightly the light emission of sodium (see Fig. 10).

(2) Sodium increases the light emission of potassium (see Figs. 12 and 13). The effect is not due to the sodium *D* line passing the filter, since pure sodium chloride solutions give very small readings (Fig. 12). This effect can be eliminated by the use of a butane-air flame.

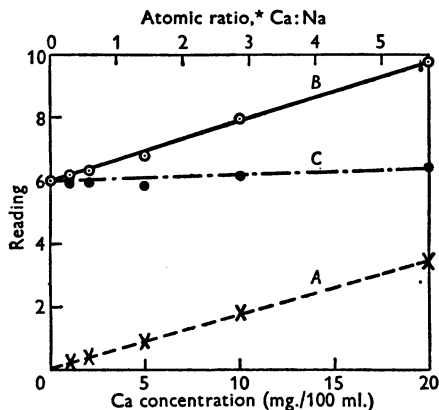

Fig. 9. Flame photometer readings for sodium. Effect of calcium. *A*, readings for calcium (as CaCl_2); *B*, readings for calcium solutions, each containing 2 mg. Na/100 ml.; $C = B - A$. (* These values refer to curve *B* only.)

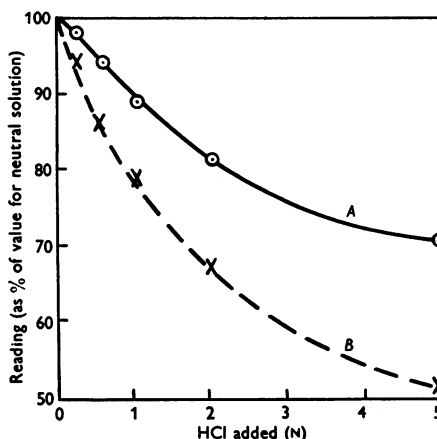

Fig. 11. Flame photometer readings for sodium and potassium. Effect of acid. *A*, 2 mg. Na/100 ml. (as NaCl) in all solutions; *B*, 2 mg. K/100 ml. (as KCl) in all solutions; HCl added as shown by abscissae.

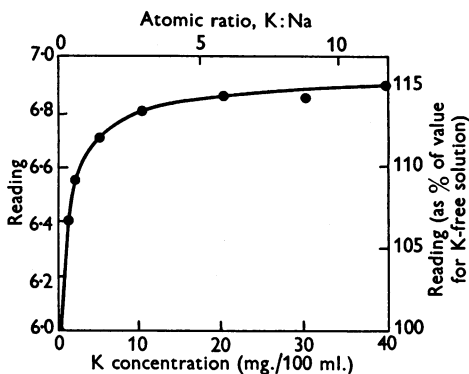

Fig. 10. Flame photometer readings for sodium. Effect of added potassium; 2 mg. Na/100 ml. (as NaCl) in all solutions; K (as KCl) added as shown by abscissae.

of the nitrates, sulphates, dihydrogen phosphates, monohydrogen phosphates, carbonates and acetates of sodium and potassium, each containing 3 mg. Na or K/100 ml. were sprayed. In all cases the galvanometer readings were identical with those for chloride solutions of the same sodium or potassium concentration.

Mutual interference of cations. The following results have been obtained with the instrument described in this paper.

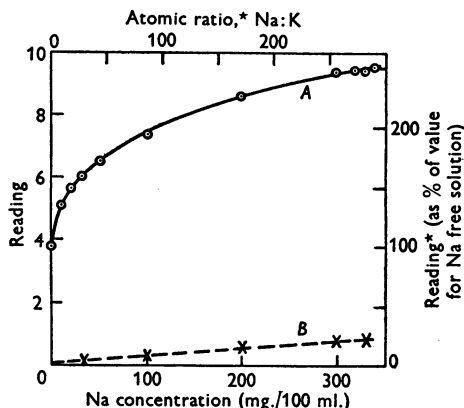

Fig. 12. Flame photometer readings for potassium. Effect of sodium. *A*, solutions containing 2 mg. K/100 ml. (as KCl) + Na (as NaCl) as shown by abscissae; *B*, solutions containing no K, but Na as shown by abscissae. (* These values refer to curve *A* only.)

(3) Some light emitted by calcium ions (presumably the 618 and 620 $m\mu$. lines) passes the sodium filters. The intensity of this light is not sufficient to cause any significant difference in the sodium readings on plasma. Results for solutions containing sodium and calcium show that the

galvanometer readings are the sum of those for the corresponding concentrations of sodium and calcium in separate solutions (see Fig. 9).

(4) No calcium light passes the potassium filter, and there is no interference between calcium and potassium in the flame.

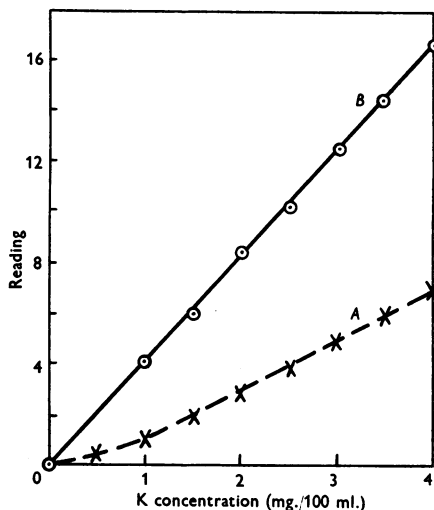

Fig. 13. Flame photometer readings for potassium. Standard curves. A, KCl solutions; B, KCl solutions each containing 330 mg. Na/100 ml. (as NaCl), used as standards in serum and urine K determinations.

(5) The presence of acid lowers the galvanometer readings for sodium or potassium. This lowering is not significant for acid concentrations below 0.2N (see Fig. 11).

(6) Ammonia added as ammonium chloride (20 mg. NH_3 /100 ml.) to solutions had no effect on the photometer readings for sodium or potassium.

Applications in medical biochemistry

The use of the flame photometer in the determination of plasma sodium, serum potassium, urine sodium and urine potassium has been discussed by Hald (1947), who compared the results obtained by the flame photometer and by chemical methods.

Plasma sodium. Plasma (0.2 ml.) is washed from an Ostwald pipette into water (19.8 ml.) giving a 1:100 dilution. These solutions are then sprayed and compared with sodium chloride standards containing 2.5, 3.0 and 3.5 mg. Na/100 ml. It is not necessary to remove protein; and potassium and calcium (in the quantities present in plasma) do not interfere. A specimen protocol showing duplicate readings for test and standard solutions is given in Table 1.

The precision of the method was tested as follows. One hundred samples of standard sodium chloride solutions, of concentrations from 250 to 350 mg. Na/100 ml., representing plasma sodium values, were diluted and sprayed by the method described. The root mean square difference between 'found' and 'calculated' values was 5.4 mg. Na/100 ml. Quality control limits for single observations in routine work are therefore as follows: 90% limits, ± 8.9 mg. Na/100ml., 99% limits, ± 14.0 mg. Na/100 ml.

Table 1. Determination of sodium in plasma. Specimen flame photometer readings and results

Sample	Plasma (diluted 1:100) Readings	Sodium standards (mg. Na/100 ml.)				Results (mg. Na/100 ml.)
		2.5	3.0	3.5	4.0	
A	6.0	—	5.5	6.4	—	328
	6.1	—	5.6	6.4	—	330
B	5.2	4.3	5.4	—	—	291
	5.3	4.4	5.6	—	—	287

Urine sodium. These determinations are carried out as for plasma sodium determinations; 1:100 dilution is usually suitable.

Serum potassium. Normal serum contains about sixteen times as much sodium as potassium, and with this apparatus it is necessary to allow for this by adding sodium to the potassium standards used for comparison. Fig. 12 shows that for a set of sera (W, X, Y, Z) containing 20 mg. K/100 ml. and varying concentrations of sodium (say 250, 300, 330 and 350 mg./100 ml.) the flame-photometer readings for potassium after dilution 1:10 with water would show considerable differences. These differences may be reduced to negligible proportions by diluting the sera not with water, but with a solution of sodium chloride containing 330 mg. Na/100 ml. (representing the mean of normal serum sodium values). If the above sera were diluted 1:10 with this solution, the resulting solutions would have the following concentrations (all in mg./100 ml.):

	Original K	Original Na	Final K	Final Na
W	20	250	2.0	322
X	20	300	2.0	327
Y	20	330	2.0	330
Z	20	350	2.0	332

The galvanometer readings for 2.0 mg. K/100 ml. solutions containing 320–340 mg. Na/100 ml. are identical within the limits of experimental error. Thus, if sera are diluted with this solution containing 330 mg. Na/100 ml. and used with potassium standards containing 330 mg. Na/100 ml., the results

are dependent only on the potassium concentrations of the sera.

A series of twenty-two sera were analysed for potassium by this method and by the colorimetric method of Abul-Fadl (1949). The results, with two exceptions, agreed within 2 mg. K/100 ml. and the root mean square deviation was 1.7 mg. K/100 ml. Potassium added to normal serum up to a total concentration of 40 mg. K/100 ml. could be determined with an accuracy of ± 1 mg. K/100 ml.

Urine potassium. If urines are diluted with the 330 mg. Na/100 ml. solution and compared in the flame photometer with the potassium standards used for sera, the results are considerably higher than those obtained by the cobaltinitrite method of Abul-Fadl (1949). However, if the urines are evaporated to dryness and ashed overnight at 400°, flame-photometer determinations on the ashed material show tolerable agreement (within $\pm 10\%$) with the cobaltinitrite results (Table 2). Preliminary attempts to trace the cause of the discrepancies in the unashed urine have had no success. The addition of urea (in the quantities commonly found in urine) to potassium standards did not affect the flame photometer results.

Table 2. *Determination of potassium in urine. Comparison of results by flame photometer and colorimetric methods*

(Flame photometer results for unashed urine were obtained by diluting the fresh urine with 330 mg. Na/100 ml. solution. Results for ashed urine were obtained by ashing duplicate samples by the procedure given on this page and carrying out flame photometer and colorimetric determinations (Abul-Fadl, 1949) on the ash.)

Urine sample	Potassium concentrations (mg./100 ml.)			Differences (%)	
	Unashed; flame photometer	Ashed; flame photometer	Ashed; colorimetric	$100 \frac{a-c}{c}$	$100 \frac{b-c}{c}$
	a	b	c		
A	92	77	80	+15	-3
		74	70	+37	+6
B	175	153	145	+21	+6
		153	155	+16	-1
C	166	150	155	+7	-3
		144	140	+18	+3
D	237	216	240	+1	-10
		222	245	+3	-9
E	230	197	200	+15	-2
		188	175	+31	+7
F	395	325	300	+31	+8
		380	340	+16	+12

The following method has been found suitable. Urine (2 ml.) is evaporated to dryness in a porcelain crucible on the steam bath. The residue is charred by

gentle heating with a Bunsen burner and ashed overnight in a muffle furnace at 400°. The colourless ash is dissolved in 5 ml. of a solution containing 5.43 g. NaCl and 3.65 g. HCl/l. (330 mg. Na/100 ml.; 0.1N in HCl) and the resulting solution (1 or 2 ml., according to K concentration of urine) is diluted to 20 ml. with NaCl solution containing 330 mg. Na/100 ml., giving a final dilution of 1:50 or 1:25 with respect to the original urine. The solutions are then compared with potassium standards containing 330 mg. Na/100 ml.

DISCUSSION

The literature contains a number of references to the mutual interference of metals in flame photometry. The most thorough survey is that of Parks, Johnson & Lykken (1948), who found that in the Perkin-Elmer Model 18 photometer, burning natural gas, sodium readings were lowered by the presence of many metallic salts, including potassium salts, and also by ammonium salts and by acids; potassium readings were lowered by the presence of many metallic salts, including sodium salts, and also by ammonium salts and by acids. Berry, Chappell & Barnes (1946) obtained similar results using an instrument built by the American Cyanamid Co.

Several continental workers (Jansen, Heyes & Richter, 1934; Rauterberg & Knippenberg, 1940; Riehm, 1945, 1948; Boon, 1945) using instruments burning acetylene, which gives a higher flame temperature than the natural gas used in the American instruments, have found, like the present authors, that the foreign metals increase the readings for sodium or potassium. In some cases (Jansen *et al.* 1934; Boon, 1945) the interference effects depended to some extent on the type of optical system used (glass filter, Christiansen filter or monochromator), and some or all of the increase in the readings may have been due to the fact that the optical systems were not isolating the required spectral lines. Riehm (1948) states that sodium increases potassium readings and that potassium increases sodium readings when acetylene is burnt; if, however, illuminating gas is burnt in the same apparatus these two metals do not interfere. The Perkin-Elmer Corporation (1945) also state that with their Model 18 photometer, lithium, sodium and potassium interfere mutually when acetylene is used, but not when illuminating gas is used.

So far as the effects of anions present in the solutions are concerned, Parks *et al.* (1948) and Berry *et al.* (1946) found that the nature of the acids added to solutions of sodium or potassium salts influenced the results considerably. Crismon (1948) found that solutions containing phosphate gave low results for sodium and potassium. Shapiro & Hoagland (1948) found that phosphate had no influence on potassium

results; they pointed out, however, that they were using much lower concentrations than Crismon.

It appears from these scattered and rather confused data that an investigation of these interference effects from the standpoint of the spectroscopist would be desirable.

SUMMARY

1. The construction and operation of a photoelectric flame photometer are described.

2. The use of the photometer for the determination of sodium and potassium in blood and urine is described.

3. The interference between various cations in the flame is discussed with reference to previous work on the subject.

We are indebted to Prof. E. J. King for his interest and encouragement, to Messrs C. Lordan and W. Weedon for constructing the photometer in use at the Postgraduate Medical School, to Messrs R. A. Brennan and J. Gray for much technical assistance, and to Miss S. Tompkins for drawing the figures.

REFERENCES

- Abul-Fadl, M. A. M. (1949). *Biochem. J.* **44**, 282.
 Barnes, R. B., Richardson, D., Berry, J. W. & Hood, R. L. (1945). *Industr. Engng Chem.* (Anal. ed.), **17**, 605.
 Berry, J. W., Chappell, D. G. & Barnes, R. B. (1946). *Industr. Engng Chem.* (Anal. ed.), **18**, 19.
 Boon, S. D. (1945). *Vlam-Fotometrie*. Amsterdam: Centen.
 Crismon, J. M. (1948). *Fed. Proc.* **7**, 24.
 Domingo, W. R., Klyne, W. & Weedon, W. (1948). *Biochem. J.* **42**, xxxvi.
 Hald, P. M. (1947). *J. biol. Chem.* **167**, 499.
 Jansen, H. W., Heyes, J. & Richter, C. (1934). *Z. phys. Chem. A*, **174**, 291.
 King, E. J. (1947). *Microanalysis in Medical Biochemistry*, p. 147. London: Churchill.
 Klyne, W. (1948). *Biochem. J.* **43**, xxv.
 Klyne, W. (1949). *Spectrochim. Acta* (in the Press).
 Lundegårdh, H. (1929-34). *Die quantitative Spektralanalyse der Elemente*. Jena: Fischer.
 McClelland, J. A. C. & Whalley, H. K. (1941). *J. Soc. chem. Ind., Lond.*, **60**, 288.
 Mitchell, R. L. (1948). *The Spectrographic Analysis of Soils, Plants and Related Materials*. Harpenden: Commonwealth Bureau of Soil Science.
 Parks, T. D., Johnson, H. D. & Lykken, L. (1948). *Anal. Chem.* **20**, 822.
 Perkin-Elmer Corporation (1945). *Instruction Manual for Operation of Model 18 Flame Photometer*. Glenbrook, Connecticut.
 Rauterberg, E. & Knippenberg, E. (1940). *Angew. Chem.* **53**, 477.
 Riehm, H. (1945). *Bodenk. und PflErnähr.* **36**, 109; *Chem. Abstr.* **41**, 4600.
 Riehm, H. (1948). *Z. anal. Chem.* **128**, 249.
 Shapiro, S. & Hoagland, H. (1948). *Amer. J. Physiol.* **153**, 428.

Vitamin A in Seals

By K. RODAHL AND A. W. DAVIES*

Institute of Physiology, Oslo University, Norway and Department of Animal Health, University College of Wales, Aberystwyth

(Received 22 February 1949)

Specimens of livers of polar bears and bearded seals (*Erignathus barbatus*) collected during the 1939-40 expedition to north-east Greenland (Rodahl, 1943) were found by Rodahl & Moore (1943) to be very rich in vitamin A. During a further expedition to the sealing grounds off Newfoundland and Labrador, carried out under the auspices of the Royal Norwegian Government between March and May 1941, the vitamin A content of seal liver was further investigated. During this expedition the livers of hooded seals (*Cystophora cristata*) and Greenland seals (*Phoca groenlandica*) were weighed and assayed for vitamin A (considerable work on the extraction of vitamin A from this source was also carried out), whilst a limited

number of determinations was made on other tissues. The present paper deals also with the results of similar analyses by one of us of material from a single specimen of the Atlantic seal (*Halichoerus grypus*), obtained off the Pembrokeshire coast in October 1946, from two specimens of the common seal (*Phoca vitulina*) obtained in the Wash in August, 1947, and from the four specimens of *Cystophora cristata* collected in the pack-ice east of Greenland in July 1948.

EXPERIMENTAL

Vitamin A was determined colorimetrically, following the alkaline digestion procedure described by Davies (1933), except for the four 1948 specimens in which the determinations were made spectrographically. All specimens from the sealing grounds off Newfoundland and Labrador were dealt

* Now with the Animal Health Trust, Houghton Grange, Huntingdonshire.