

## Actinomycin D Binds Strongly to d(CGACGACG) and d(CGTCGTTCG)

Feng Sha and Fu-Ming Chen

Department of Chemistry, Tennessee State University, Nashville, Tennessee 37209-1561 USA

**ABSTRACT** Earlier calorimetric studies had indicated that despite the absence of a GpC sequence, the self-complementary octamer d(CGTCGACG) binds strongly to actinomycin D (ACTD) with high cooperativity and a 2:1 drug/duplex ratio. A subsequent optical spectral study with related oligomers led us to suggest that ACTD may likely stack at the G · C basepairs of the duplex termini. New findings are reported herein to indicate that despite the lack of complete self-complementarity, oligomers of d(CGXCGXCG) [X = A or T] motif exhibit unusually strong ACTD affinities with binding constants of roughly  $2 \times 10^7 \text{ M}^{-1}$  and binding densities of 1 drug molecule per strand. The ACTD binding affinity for the corresponding heteroduplex obtained by annealing these two oligomers is, however, considerably reduced. Although spectroscopic results with related oligomers obtained by removing, replacing, or appending bases at the termini appear to be consistent with the end-stacking model, capillary electrophoretic (CE) evidence provides additional insights into the binding mode. CE experiments with the self-complementary oligomers d(CGAGCTCG) and d(CGTCGACG) revealed contrasting migration patterns in the presence of ACTD, with mobility retardation and acceleration exhibited by the GpC- and non-GpC-containing octamers, respectively, whereas the X/X-mismatched d(CGXCGXCG) experienced retardation. These results, along with those of related oligomers, suggest that ACTD may in fact stack at the duplex stem end of a monomeric hairpin or at the 3'-end of dG as a single strand. The seemingly cooperative ACTD binding and the curved Scatchard plot for the self-complementary d(CGTCGACG) may thus be attributed to the drug-induced duplex denaturation resulting from strong binding to single strands of d(CGXCGYCG) motif. Detailed structural information on the ACTD-DNA complexes, however, must await further NMR investigations.

### INTRODUCTION

Actinomycin D (ACTD) is an antitumor antibiotic that contains a 2-aminophenoxazin-3-one chromophore and two cyclic pentapeptide lactones. This drug has been used clinically for the treatment of highly malignant tumors, such as Wilms' tumor (Farber, 1966) and gestational choriocarcinoma (Lewis, 1972; Schink et al., 1992), and has also been used in combination with other antitumor agents to treat high-risk tumors (Newlands et al., 1991; Marina et al., 1992; Nakamura et al., 1992).

A wealth of information has been compiled regarding the interaction of ACTD with DNA. It is well known that ACTD prefers duplex DNA and binds via intercalation of the planar chromophore, preferably at the GpC sequence, with the two pentapeptide rings resting on the minor groove (see the schematic drawing of Fig. 1 A). A model of DNA-ACTD complex has been generally accepted in which the phenoxazine ring is intercalated between the G · C and C · G basepairs (where guanine residues are on opposite strands), forming strong hydrogen bonds in the minor groove between the guanine 2-amino groups and the carbonyl oxygen atoms of the L-threonine residues of the cyclic pentapeptides (Sobell et al., 1971; Sobell and Jain, 1972). Additional stabilizations are derived from hydropho-

bic interactions between groups on the pentapeptides and sugar residues, and from other specific weaker hydrogen bonds (Kamitori and Takusagawa, 1992, 1994). Because the pentapeptide rings of this drug span ~4–5 basepairs the binding affinity of ACTD is expected, and indeed was found, to be affected by adjacent and neighboring bases (Scramrov and Beabealashivilli, 1983; Goodisman et al., 1992; Chen, 1988, 1992).

However, there have been recent reports to indicate that ACTD may also bind strongly via some non-classic modes, such as to single-stranded DNA (Wadkins and Jovin, 1991; Hsieh et al., 1994; Wadkins et al., 1996, 1998) and to some DNA sequences containing no GpC site (Rill et al., 1989; Snyder et al., 1989; Bailey et al., 1994; Rill and Hecker, 1996). In particular, calorimetric studies by Snyder et al. (1989) have indicated that despite the absence of a GpC sequence ACTD can bind cooperatively to the octamer d(5'CGTCGACG3') with a binding constant on the order of  $10^7 \text{ M}^{-1}$  and a 2:1 drug/duplex stoichiometry. Further optical evidence from this laboratory led us (Chen and Liu, 1996) to postulate that ACTD may in fact stack on the G · C basepairs at both ends of this oligomeric duplex (see schematic drawing of Fig. 1 B). This was based on the rationale that the classic intercalative preference of ACTD for 5'G3'p5'C3' implies that the drug favors the 3' side of dG.

Further studies in this laboratory have led to new findings that despite the lack of complete self-complementarity and the absence of GpC sequence, octamers d(5'CGTCGTTCG3') and d(5'CGACGACG3') also bind tightly to ACTD. In an attempt to understand the nature and to delineate the origin of such a strong binding, studies were made with these and related oligomers using capillary electrophoretic and various spectro-

Received for publication 18 January 2000 and in final form 26 June 2000.

Address reprint requests to Dr. Fu-Ming Chen, Department of Chemistry, Tennessee State University, Nashville, TN 37209-1561. Tel.: 615-963-5325; Fax: 615-963-5434; E-mail: fchen@tnstate.edu.

© 2000 by the Biophysical Society

0006-3495/00/10/2095/10 \$2.00

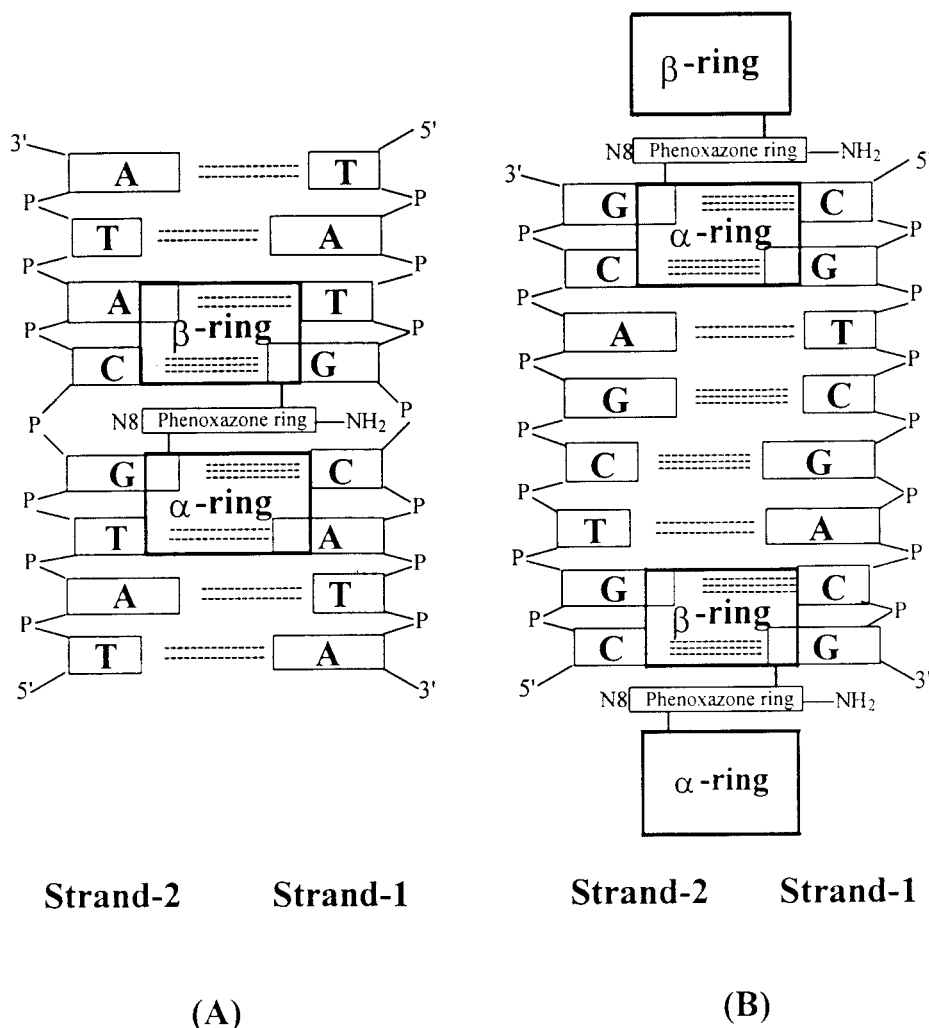

FIGURE 1 Schematic drawings of intercalative binding mode of ACTD at the GpC site (A) and the earlier proposed end-stacking binding mode of ACTD to d(CGXCGYCG) (B).

scopic techniques. The results of these experiments and their significance are presented and discussed in this report.

## MATERIALS AND METHODS

Synthetic oligonucleotides were purchased from Research Genetics (Huntsville, AL) and used without further purification. These oligomers were purified by the vendor via reverse-phase oligonucleotide purification cartridges and exhibited single-band electrophoretic mobilities in denaturing polyacrylamide gel electrophoresis with stated purity of  $\geq 95\%$ . Concentrations of the DNA solutions (in nucleotide) were determined by measuring the absorbances at 260 nm after melting and calculating the concentrations by Beer's law. The extinction coefficients of DNA were obtained via nearest-neighbor approximation using mono and dinucleotide values tabulated in Fasman (1975). Heteroduplex formation was accomplished by mixing equimolar amounts of the two complementary oligomers, heating the mixture to 95°C for 5 min, and slowly cooling it back to room temperature. ACTD and 7-amino-ACTD were purchased from Serva (Hauppauge, NY). Concentrations of the drug solutions were determined by measuring the absorbances at 440 nm (for ACTD) and 528 nm

(for 7-amino-ACTD), using extinction coefficients of 24,500 and 23,600  $\text{cm}^{-1} \text{M}^{-1}$ , respectively. Stock solutions for oligonucleotides and drugs were prepared by dissolving in 10 mM Tris-borate buffer solution of pH 8 containing 0.1 M NaCl and 1 mM  $\text{MgCl}_2$ . Absorption spectra were measured with a Cary 1E spectrophotometric system. Data were collected from 600 to 350 nm. Absorption spectral titrations were carried out by starting with a 5  $\mu\text{M}$  ACTD solution of 2 ml followed by progressive additions of the oligomer stock at equal time intervals. Absorbance differences between 427 and 480 nm during absorption spectral titrations were used to obtain the binding isotherms and Scatchard plots. The binding parameters were deduced via linear least-squares fits on the linear portions of the Scatchard plots. The bound extinction coefficients were estimated through extrapolations to high DNA concentrations. Circular dichroic (CD) spectra were measured at room temperature with a Jasco J-500A recording spectropolarimeter using water-jacketed cylindrical cells of 2-cm pathlength. The data were collected from 350 to 230 nm with a scan speed of 50 nm/min. The CD difference spectra were obtained by subtracting out the spectra of 40  $\mu\text{M}$  oligomers (per nucleotide) from those in the presence of 7  $\mu\text{M}$  ACTD. Fluorescence spectra were obtained at 20°C with an SLM 48000S system. Emission spectra were measured in the region of 580–780 nm with

560 nm excitation, whereas excitation spectra were taken in the region of 420–600 nm with 650 nm emission monitoring.

Capillary electrophoretic experiments were carried out with a Beckman P/ACE 5000 instrument. Capillary electrophoresis oligonucleotide run buffer and 75  $\mu\text{m}$  ID  $\times$  375  $\mu\text{m}$  OD capillaries internally coated with poly(AAEE) were purchased from Bio-Rad (Hercules, CA). Samples were loaded by pressure for 10 s and run at 15 kV and 25°C with 254 nm absorbance detection. The sieving buffer was replenished before each run using a 5-min purge cycle at 20 p.s.i. pressure. Two water rinse cycles were used to remove residual buffer from the capillary and electrode surfaces to prevent buffer carryover into the sample vial.

## RESULTS

### Unusually strong ACTD binding of d(CGACGACG) and d(CGTCGTCC)

Representative absorption spectral alterations during a typical titration are illustrated with the ACTD + d(CGACGACG) system, and are shown in Fig. 2 A. ACTD exhibits

an absorption maximum near 440 nm in buffer solutions and without the presence of DNA. Progressive additions of DNA oligomeric stock result in considerable hypochromic effects of this band and slight bathochromic shifts to result in small hyperchromic effects around 480 nm. The observed hyperchromic effects near 480 nm, however, are significantly less than those observed in ACTD titrations with GpC-containing oligomers (Chen, 1988, 1992). Absorbance differences between 427 and 480 nm were used to construct the binding isotherms and some representative Scatchard plots are shown in Fig. 2, B–D. Most of the plots appear to be approximately linear and the extracted binding parameters via linear least-squares fits along with some melting results are summarized in Tables 1–3. It is apparent that despite the absence of a GpC sequence and complete self-complementarity, both d(5'CGTCGTCC3') and d(5'CGACGACG3') bind strongly to ACTD with binding constants

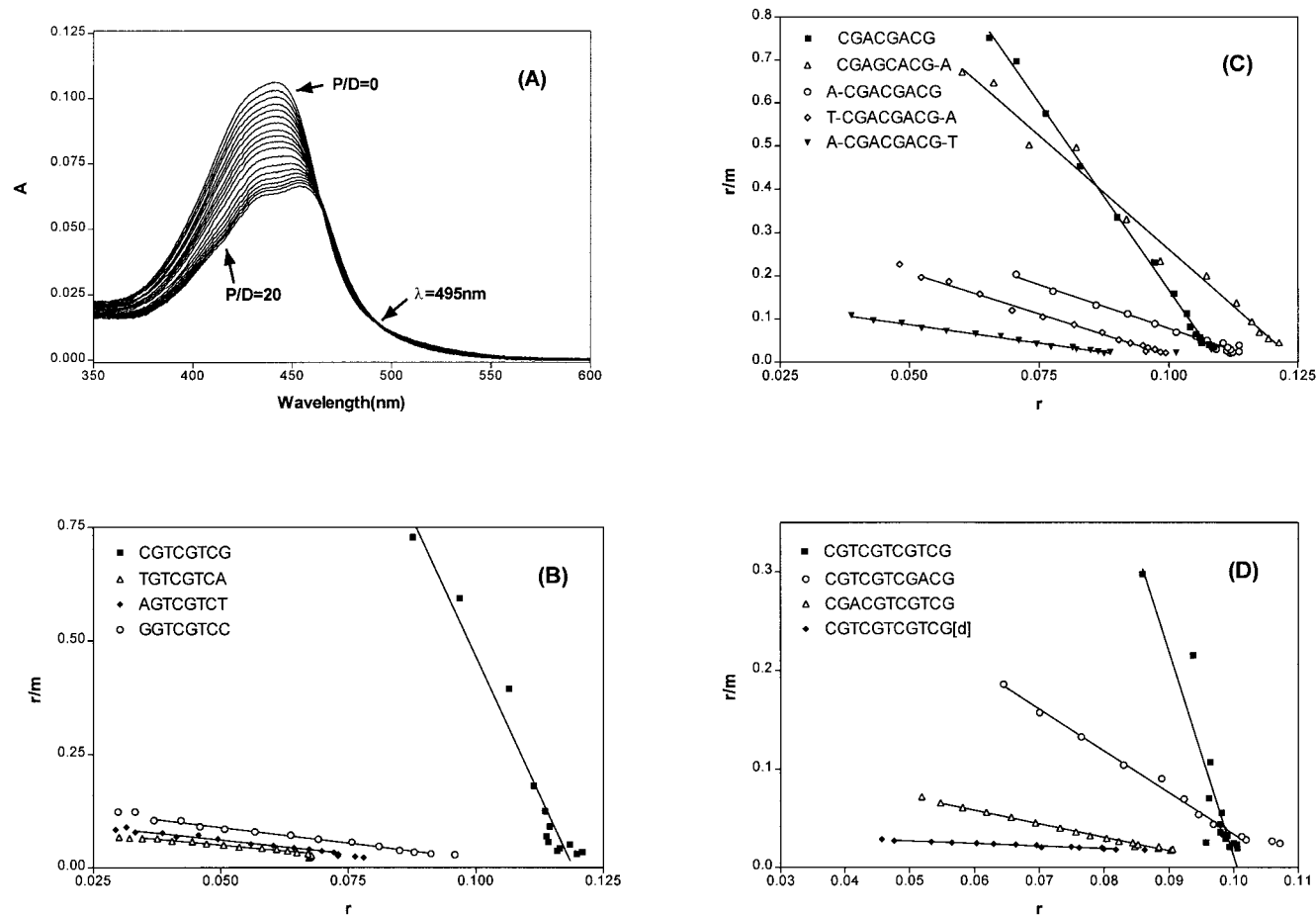

FIGURE 2 (A) Typical spectral alterations during absorption spectral titrations as illustrated by the ACTD + d(CGACGACG) system. [nucleotide]/[drug] ratio is designated by P/D. (B) Comparison of Scatchard plots for ACTD binding to d(CGXCGXCG) and oligomers derived via end base replacement, as typified by X = T series. (C) Comparison of Scatchard plots for d(CGXCGXCG) and oligomers derived via appending base(s) at the terminal(s), as typified by X = A series. (D) Comparison of Scatchard plots for d(CGXCGXCGXCG) and some related oligomers, as typified by X = T series. Spectral titrations were carried out at 20°C and the absorbance differences between 427 and 480 nm were used to obtain the binding isotherms. [Bound drug]/[DNA, nucleotide] is designated by  $r$ , and  $m$  represents the free drug concentration (in  $\mu\text{M}$ ).

**TABLE 1** Comparison of ACTD binding parameters at 20°C for d(CGXCGXCG) and some related oligomers via replacement or removal of end base(s)

Oligomer	K ( $\mu\text{M}^{-1}$ )	<i>n</i> /Strand
CGTCG	0.8 ± 0.1	
GTCGTC	0.7 ± 0.1	
CTCGTG	<0.3	
<b>CGTCGTCG</b>	25 ± 2	1.0 ± 0.1
GGTCGTC	1.5 ± 0.1	
TGTCGTC	1.7 ± 0.1	
AGTCGTC	1.8 ± 0.1	
CGACG	0.7 ± 0.1	
GACGAC	0.7 ± 0.1	
CACGAG	<0.3	
<b>CGACGACG</b>	17.2 ± 0.7	0.9 ± 0.1
GGACGACC	0.6 ± 0.1	
TGACGACA	0.9 ± 0.1	
AGACGACT	0.5 ± 0.1	

Parent octamers are designated by bold-face.

of  $2.5 \times 10^7$  and  $1.7 \times 10^7 \text{ M}^{-1}$ , respectively, and with binding densities of  $\sim 1$  drug molecule per strand. The strong ACTD binding affinities are also evidenced by huge melting temperature increases upon ACTD binding. In the absence of ACTD, these two octamers do not exhibit cooperative melting above 20°C at 40  $\mu\text{M}$  nucleotide concentrations and 0.1 M NaCl. However, dramatic ACTD-induced duplex stabilization resulted in melting temperatures of 65 and 66°C for the drug complexes of d(CGTCGTCG) and d(CGACGACG), respectively, exhibiting increases of >45°C (see Table 2).

**TABLE 2** Comparison of ACTD binding parameters at 20°C for d(5'CGXCGXCG3') and related oligomers via appending base(s) at the terminal(s)

Oligomer	K ( $\mu\text{M}^{-1}$ )	<i>n</i> /Strand	$T_m^\circ$ (°C)	$T_m$ (°C)
<b>CGTCGTCG</b>	25 ± 2	1.0 ± 0.1	<20	65
<b>CGACGACG</b>	17.2 ± 0.7	0.9 ± 0.1	<20	66
CGTCGTCG[d]	3.1 ± 0.1	1.1 ± 0.1	41	66
CGTCGTCG-T	15 ± 1	0.9 ± 0.1	<20	68
A-CGACGACG	4.1 ± 0.1	1.1 ± 0.1	$\sim 20$	62
CGTCGTCG[d]	0.7 ± 0.1			
T-CGTCGTCG	13 ± 2	0.7 ± 0.1	$\sim 20$	65
CGACGACG-A	10.5 ± 0.4	1.1 ± 0.1	<20	68
T-CGTCGTCG[d]	0.5 ± 0.1			
A-CGTCGTCG-T	4.5 ± 0.1	1.0 ± 0.1		
A-CGACGACG-T	1.7 ± 0.1			
A-CGTCGTCG-T[d]	0.9 ± 0.1			
T-CGTCGTCG-A	5.04 ± 0.01	1.1 ± 0.1		
T-CGACGACG-A	3.83 ± 0.09	1.0 ± 0.1		
T-CGTCGTCG-A[d]	0.4 ± 0.1			

$T_m^\circ$  and  $T_m$  designate the estimated ( $\pm 0.5^\circ\text{C}$ ) melting temperatures of 40  $\mu\text{M}$  DNA (nucleotide) in the absence and in the presence of 7  $\mu\text{M}$  ACTD, respectively. Absorbance changes on melting were monitored at 275 nm. Heteroduplex is designated by [d].

## Replacement or removal of end bases results in considerably weaker ACTD binding affinity

The ACTD binding parameters for the parent octamers and oligomers derived from replacing the end bases of d(5'CGTCGTCG3') and d(5'CGACGACG3') are compared in Table 1, and some representative Scatchard plots are shown in Fig. 2 B. More than an order of magnitude reduction in the binding affinities is seen for these end base-replaced oligomers. For example, d(5'GGTCGTC3') and d(5'GGACGACC3') exhibit binding constants of  $1.5 \times 10^6$  and  $0.6 \times 10^6 \text{ M}^{-1}$ , as compared to  $2.5 \times 10^7$  and  $1.7 \times 10^7 \text{ M}^{-1}$  for the parent octamers d(5'CGTCGTCG3') and d(5'CGACGACG3'), respectively. A similar reduction in the ACTD binding affinity is seen with the removal of terminal bases from both ends to result in hexamers of the form d(5'GXCGXC3') or with the removal of an XCG unit from the parent octamers to result in pentamers of the form d(5'CGXCG). Binding constants of  $\sim 7 \times 10^5 \text{ M}^{-1}$  were obtained for these oligomers that are more than an order of magnitude weaker than those of the parent octamers. Hexamers of the form d(5'CXCGXG3'), with somewhat altered sequence but containing C, G bases at the respective 5' and 3' ends, did not appear to improve the ACTD binding affinity.

## Appending bases at sequence termini results in somewhat reduced binding affinities

Binding parameters for oligomers obtained by appending dA and/or dT to the 5' and/or 3' end(s) are compared in Table 2, and the representative Scatchard plots are shown in Fig. 2 C. Although the binding affinities of the single base-appended oligomers are somewhat diminished from the parent oligomers, their binding strengths are still quite substantial. Addition of a dT at the 5' or 3' end of d(5'CGTCGTCG3') resulted in a binding constant of  $1.3 \times 10^7$  or  $1.5 \times 10^7 \text{ M}^{-1}$ , respectively, a slight decrease from that of  $2.5 \times 10^7 \text{ M}^{-1}$  of the parent octamer. Similarly, addition of dA at the 5' or 3' end of d(5'CGACGACG3') resulted in a binding constant of 0.4 or  $1.1 \times 10^7 \text{ M}^{-1}$ , respectively, which is to be compared with  $1.7 \times 10^7 \text{ M}^{-1}$  of the parent octamer. Oligomers with bases appended at both ends exhibit further reduction (at least 2-fold) in binding affinities from the corresponding single base-appended oligomers, with binding constants now ranging from  $1.7$  to  $5 \times 10^6 \text{ M}^{-1}$ .

## ACTD also binds strongly to d(5'CGTCGTCGTCG3') and d(5'CGACGACGACG3') with 1:1 drug/strand ratios

Binding studies with 11-mers d(5'CGTCGTCGTCG3') and d(5'CGACGACGACG3') and some related oligomers were

**TABLE 3** Comparison of ACTD binding parameters for d(5'CGXCGXCG3') and related oligomers at 20°C

Oligomer	K ( $\mu\text{M}^{-1}$ )	n/Strand	$T_m^\circ$ ( $^\circ\text{C}$ )	$T_m$ ( $^\circ\text{C}$ )
CGTCGTCGTCG	$21 \pm 3$	$1.1 \pm 0.1$	32	76
CGACGACGACG	$20 \pm 1$	$1.1 \pm 0.1$	28	78
CGTCGTCGTCG[d]	$0.3 \pm 0.1$		56	75
CGTCGTCGACG	$4.2 \pm 0.1$	$1.1 \pm 0.1$	40	78
CGACGTCGTCG	$1.4 \pm 0.1$		52	77
CGTCGTCGTCG-T	$14 \pm 1$	$1.0 \pm 0.1$		
A-CGACGACGACG	$2.0 \pm 0.1$			
A-CGACGACGACG[d]	$1.5 \pm 0.1$			
T-CGTCGTCGTCG	$13 \pm 1$	$1.2 \pm 0.1$		
CGACGACGACG-A	$11.7 \pm 0.8$	$1.0 \pm 0.1$		
T-CGTCGTCGTCG[d]	$<0.2$			

$T_m^\circ$  and  $T_m$  designate the estimated ( $\pm 0.5^\circ\text{C}$ ) melting temperatures of 40  $\mu\text{M}$  DNA (nucleotide) in the absence and in the presence of 7  $\mu\text{M}$  ACTD. Absorbance changes on melting were monitored at 275 nm. Heteroduplex is designated by [d].

also made, and the results are compared in Table 3; the representative Scatchard plots are shown in Fig. 2 D. These two 11-mers are obtained by adding one additional XCG unit to the corresponding parent octamers. It is apparent that both of these 11-mers exhibit strong ACTD binding with roughly  $2 \times 10^7 \text{ M}^{-1}$  in binding constant, comparable to those of the corresponding parent octamers. Most interestingly, the extracted binding densities are also  $\sim 1$  drug molecule per strand, same as those of the parent octamers. Again, appending the oligomers with dA and/or dT reduces

the binding affinities somewhat. The strong ACTD affinities are further supported by dramatic melting temperature increases of roughly  $44^\circ\text{C}$  upon ACTD binding (see Table 3).

### Binding affinities for the corresponding heteroduplexes are considerably reduced

The parent octamers d(5'CGTCGTCG3') and d(5'CGACGACG3') are in fact complementary to each other. Thus, mixing equal molar amounts of the two oligomers will result in a predominantly heteroduplex formation at  $20^\circ\text{C}$ . Interestingly, the ACTD binding ability of the heteroduplex is considerably diminished. The binding constant obtained via Scatchard plot yielded a value of  $3.1 \times 10^6 \text{ M}^{-1}$  for the heteroduplex, contrasting those of roughly  $2 \times 10^7 \text{ M}^{-1}$  for the component strands. Similar reductions in the binding affinity of nearly an order of magnitude for the heteroduplexes are also observed for the base-appended oligomers (see Table 2). The diminished ACTD binding ability of the heteroduplex as compared to the constituent oligomers is even more dramatically illustrated by the 11-mers in which the corresponding heteroduplex exhibits a binding affinity of  $3 \times 10^5 \text{ M}^{-1}$  as compared to those of  $2 \times 10^7 \text{ M}^{-1}$  for the component oligomers, a reduction of nearly two orders of magnitude (see Table 3). The importance of proximal basepair mismatches on ACTD binding is further investigated by replacing those mismatches with basepairs and leaving only a single T/T mismatch at the center. The ACTD

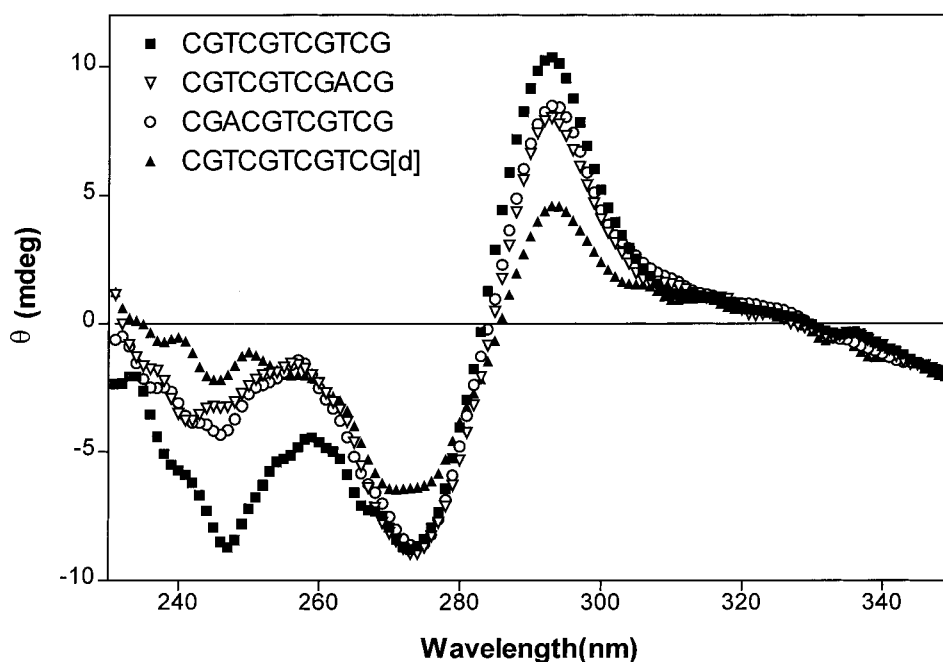

**FIGURE 3** Comparison of ACTD-induced CD spectral characteristics at room temperature for d(CGTCGTCGTCG), its heteroduplex, and some related oligomers. Spectra were measured at room temperature using a cylindrical cell of 2-cm pathlength with 40  $\mu\text{M}$  (base) of oligonucleotide in the absence and in the presence of 5  $\mu\text{M}$  ACTD. Difference CD spectra were obtained by subtracting out the contribution due to DNA.



binding affinities for the resulting 11-mers d(5'CGTCGTCGACG3') and d(5'CGACGTCGTCG3') are seen to be smaller and larger than the corresponding three X/X-mismatched d(5'CGXCGXCGXCG3') and fully basepaired d(5'CGXCGXCGXCG3')[d], respectively (see Table 3 and Fig. 2 D).

### CD measurements support the results of equilibrium binding titrations

Binding of ACTD to DNA can induce a characteristic CD spectrum consisting of positive and negative maxima near 293 and 270 nm, respectively. Thus, it is possible to obtain relative ACTD binding affinities qualitatively by comparing the induced CD intensities at 293 nm. CD difference spectral comparison (ACTD/DNA-DNA) of d(5'CGTCGTCGTCG3') and its heteroduplex, along with those of d(CGTCGTCGACG) and d(CGACGTCGTCG), are illustrated in Fig. 3. The last two oligomers are essentially self-complementary except for the dT at the center. In agreement with the results of absorbance binding titrations, d(5'CGTCGTCGTCG3') exhibits a considerably larger CD intensity at 293 nm than its heteroduplex, while the two nearly self-complementary 11-mers are intermediate of these two extremes.

CD measurements were also extended to cover the 460-nm spectral region. In contrast to the GpC containing oligomers, ACTD binding to both d(CGACGACG) and d(CGTCGTCG) induces positive rather than negative CD in this region.

### Comparison with the fluorescence results of 7-amino-ACTD

Unlike ACTD, the fluorescence of its 7-amino derivative (7-amino-ACTD) is quite substantial. It is thus of interest to corroborate the ACTD results with those of this derivative via fluorescence measurements because its 7-amino group substitution has been shown not to greatly alter the intercalative binding nature of this derivative. The binding of 7-amino-ACTD with DNA usually results in an enhanced fluorescence emission spectrum exhibiting a maximum near 650 nm and a fluorescence intensity enhancement near 540 nm in the excitation spectrum with 650-nm emission monitoring. Difference fluorescence excitation spectra (drug/DNA–drug), as typified by d(CGTCGTCG) and related oligomers, are compared in Fig. 4. Consistent with the weaker ACTD binding affinities, the double base-appended oligomers exhibit somewhat lower fluorescence intensities than those of the single base-appended ones, whereas all the base-appended oligomers induce significantly stronger fluorescence than the parent octamers.

### Capillary electrophoretic profiles

Capillary electropherograms of d(CGTCGTCG), d(CGTCGACG), and d(CGAGCTCG) in the absence (*lower trace* of each panel) and in the presence of ACTD (*upper trace* of each panel) are compared in Fig. 5. Consistent with a

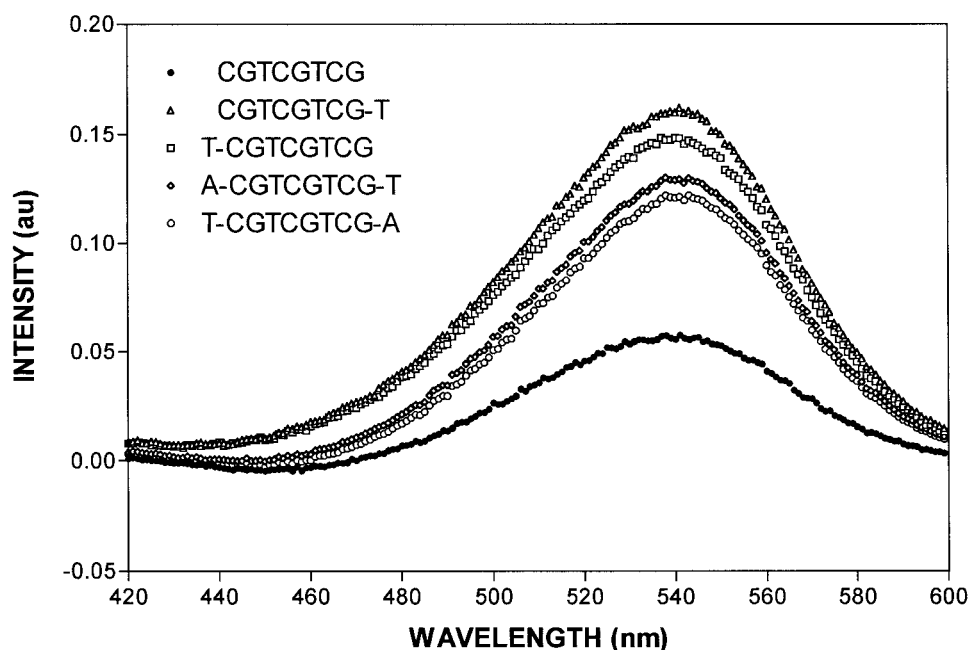

FIGURE 4 Comparison of difference (drug/DNA–drug, with appropriate concentration corrections) fluorescence excitation spectra of 7-amino-ACTD as induced by d(CGTCGTCG) and related oligomers derived from appending base(s) at the terminal(s). Spectra were measured with 2  $\mu$ M 7-amino-ACTD in the presence of 40  $\mu$ M nucleotide at 20°C with 650-nm monitoring of fluorescence emission.

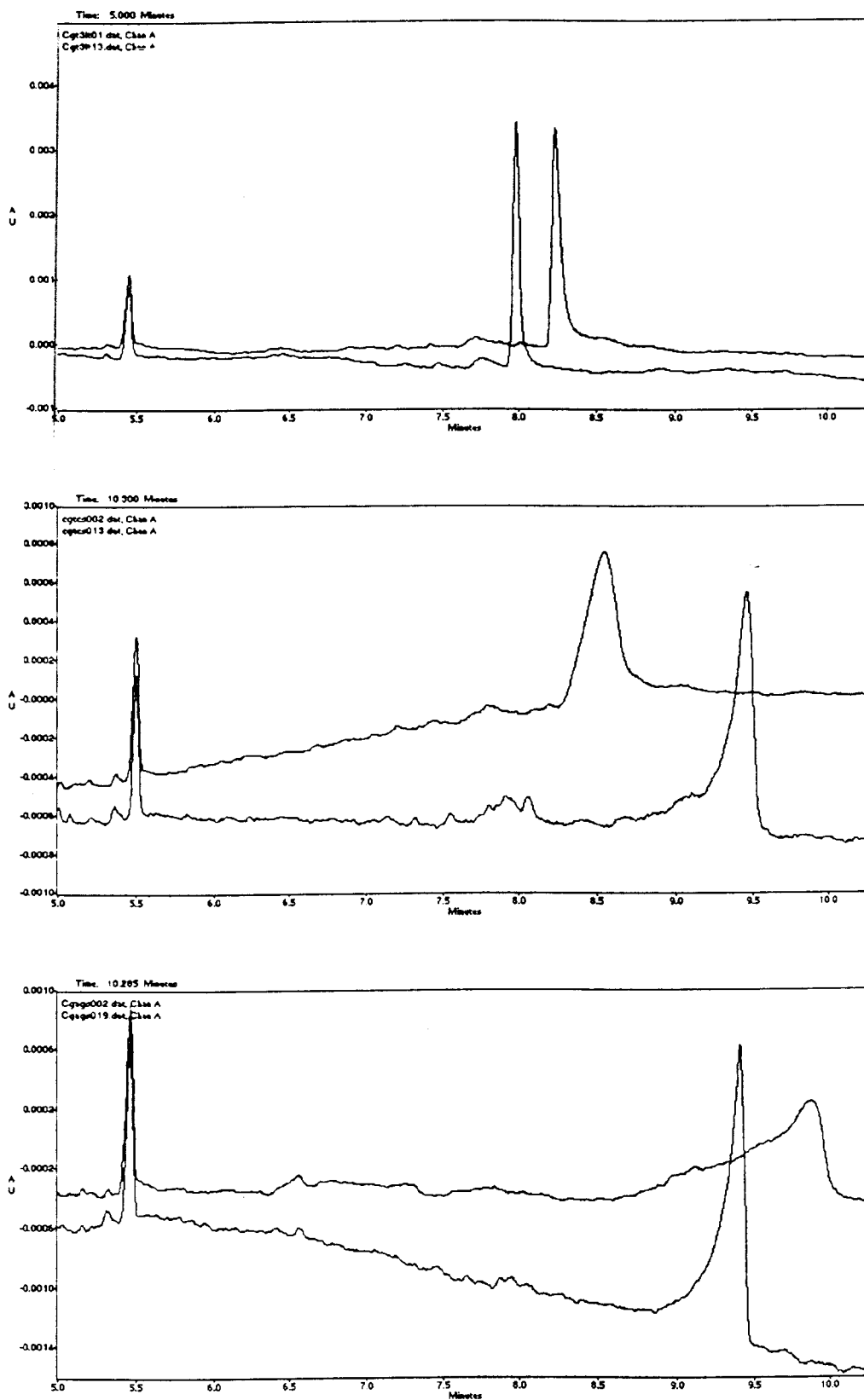

FIGURE 5 Comparison of capillary electropherograms at 25°C for d(CGAGCTCG) (*bottom*), d(CGTCGACG) (*middle*), and d(CGTCGTCG) (*top*) in the absence (*lower trace*) and in the presence (*upper trace*) of 0.8  $\mu$ M ACTD in the running buffer. DNA concentrations are roughly 0.8 mM in nucleotide.

single-stranded conformation at room temperatures, the octamer with T/T mismatches exhibits a considerably shorter migration time than those of the two self-complementary octamers, which exist mainly in the duplex form at room temperature (compare lower traces of the three panels). It is interesting that binding of ACTD resulted in distinctly different migration patterns for these oligomers. The self-complementary octamer d(CGAGCTCG) contains a central GpC site, and thus an ACTD molecule is expected to be intercalated at that location. Indeed, in the presence of ACTD in the running buffer, the electrophoretic mobility of the oligomer is retarded to result in a slower migration time (see the lower panel). In contrast, the binding of ACTD to the non-GpC-containing octamer d(CGTCGACG) resulted in a considerably faster migration time. Interestingly, a moderate retardation of electrophoretic mobility was observed for the T/T-containing d(CGTCGTCG) upon ACTD binding. CE results of these three oligomers are summarized in Table 4.

## DISCUSSION

Despite the absence of a strong binding GpC sequence and the lack of complete self-complementarity, both d(CGACGACG) and d(CGTCGTCG) exhibit unusually strong ACTD binding affinities of roughly  $2 \times 10^7 \text{ M}^{-1}$  in binding constant and  $\sim 1$  drug molecule per DNA strand in binding density. In contrast to the previously studied self-complementary counterparts (Snyder et al., 1989; Chen and Liu, 1996), the Scatchard plots for ACTD binding to d(CGXCGXCG) do not exhibit unusual curvatures. Melting experiments indicate that the melting temperatures of the X/X-mismatched octamers are below  $20^\circ\text{C}$ , whereas the ACTD-

bound complexes melt around  $65^\circ\text{C}$ , the same as those of self-complementary counterparts. Interestingly, the ACTD binding propensity of the heteroduplex formed by annealing these two oligomers together is considerably diminished. Removing as well as replacing the end bases resulted in a diminution of the ACTD binding strength by more than an order of magnitude. A slight reduction in the binding affinity for oligomers with a single-base terminal addition and a further reduction in the binding affinity upon a terminal A · T basepair addition were also observed. These results are similar to those found for the self-complementary octamer d(CGTCGACG) and appear not to contradict our earlier speculation that drug molecules stack at the terminal G · C basepairs of the duplex (Chen and Liu, 1996). Furthermore, addition of an XCG unit to the parent octamers resulted in no apparent reduction in binding affinities, and the binding densities remained  $\sim 1$  drug molecule per strand. Analogous to their parent octamers, more than an order of magnitude reduction in the binding strength is seen for the annealed heteroduplex of these 11-mers. The finding that the binding densities of 1 drug molecule per strand is maintained for the ACTD binding to the d(CGXCGXCGXCG) oligomers, despite a 3-base addition to the parent octamers, is consistent with an end-binding model because if the binding were to be at the internal sequences, the binding densities for the 11-mers would have been significantly increased.

The results of CD and fluorescence spectral measurements also appear to conform with the notion of end-stacking binding mode. Appending base(s) at one or two end(s) results in reduced CD intensities at 293 nm, and the resulting rankings are consistent with the relative binding affinities obtained via absorption spectral titrations. In contrast to binding of ACTD to GpC-containing oligomers, a positive CD intensity results in the 460-nm region upon binding to d(CGACGACG) or d(CGTCGTCG), similar to that of binding to the mononucleotide pdG (Hommer, 1969). This strongly implicates the stacking of drug at the terminal dG. Despite the fact that the extents of fluorescence enhancement of 7-amino-ACTD do not exactly correlate well with the binding order for the oligomers studied, it is apparent that changing the end bases of a sequence greatly affects the fluorescence intensities induced. The fluorescence results, however, appear to provide rather convincing evidence that the binding of ACTD to d(CGXCGXCG) occurs at the termini rather than at the internal sequences. If the binding were to occur at the internal sequences, changes at the sequence ends would not be expected to make a significant influence on the fluorescence spectral characteristics of the bound drug. However, the fluorescence results clearly indicate that when dangling bases were added at one or two sequence ends, strong fluorescence enhancements were observed. The somewhat reduced fluorescence enhancements for oligomers with dangling bases on both ends as compared to the corresponding oligomers with a single dangling base most likely resulted from significant reduc-

**TABLE 4** Comparison of capillary electrophoretic profiles at  $25^\circ\text{C}$  for d(5'CGTCGTCG3') and related oligomers in the presence and in the absence of ACTD

Oligomer	[ACTD] in DNA ( $\mu\text{M}$ )	[ACTD] in buffer ( $\mu\text{M}$ )	$\Delta t$ (min)*
d(CGAGCTCG)	0.00	0.00	3.94
	0.0	40	4.03
	0.25	40	3.84, 4.53
	0.50	40	4.48
	0.75	40	4.53
d(CGTCGACG)	0.00	0.00	3.98
	0.0	40	3.89
	0.25	40	3.39
	0.50	40	3.16
	0.75	40	3.02
d(CGTCGTCG)	0.00	0.00	2.52
	0.0	40	2.52
	0.25	40	2.65
	0.50	40	2.74
	0.75	40	2.75

\* $\Delta t$  is the migration time ( $\pm 0.02$  min) relative to that of dT, which was added as an internal reference.



tion in binding affinities (at least 2-fold) due to the extra added base, which more than compensated for the expected further intensity increase.

The interpretation of ACTD stacking at the duplex termini, however, begs the question as to why the heteroduplex formed by annealing d(CGTCGTCG) and d(CGACGACG) exhibits a dramatic reduction in ACTD binding affinity. One could argue that this may be the consequence of the fact that an optimal ACTD binding via stacking on a terminal G · C basepair requires not only strong hydrogen-bonding of the drug with the basepair, but also a snug fit for one of the pentapeptide rings in the minor groove. Because of its somewhat more rigid structure, it would be more difficult for a fully basepaired duplex to achieve an optimal fit than a duplex with a proximal basepair mismatch because the former would be less accommodating to the drug's side chains. Such a rationale would have been in line with the significant reduction in ACTD binding affinities of d(CGTCGTCGACG) and d(CGACGTCGTCG), where the two outer T/T mismatches have been replaced by A · T pairs, to  $4.2$  and  $1.4 \times 10^6 \text{ M}^{-1}$ , respectively, from that of  $2.1 \times 10^7 \text{ M}^{-1}$  for the parent 11-mer d(CGTCGTCGTCG). The fully basepaired heteroduplex d(CGTCGTCGTCG)[d] showed further reduction, with a binding constant of merely  $3 \times 10^5 \text{ M}^{-1}$ .

Additional insights into the binding mode, however, are provided by the intriguing and contrasting capillary electrophoretic migration patterns of d(CGAGCTCG) and d(CGTCGACG) with and without ACTD. Although the distinct electrophoretic behaviors are consistent with their differing binding modes, it is somewhat puzzling that an ACTD intercalation at the central GpC site resulted in a mobility retardation for d(CGAGCTCG), whereas binding of d(CGTCGACG), presumably stacking at duplex termini, resulted in a faster migration. Interestingly, the CE migration patterns of the T/T-mismatched octamer d(CGTCGTCGTCG) appear to provide a possible resolution. The considerably faster mobility of d(CGTCGTCG) in the absence of ACTD as compared to the two self-complementary octamers suggests that this oligomer exists predominantly in the single-stranded or monomeric hairpin form, and its mobility retardation in the presence of ACTD is consistent with drug binding to form a complex of higher molecular weight. Thus, the seemingly anomalous accelerated mobility upon ACTD binding to the self-complementary d(CGTCGACG) may be interpreted to be a result of drug-induced denaturation, a consequence of ACTD binding to the higher-affinity single-stranded or hairpin form to result in complexes exhibiting higher mobility than their corresponding duplex. This would explain the significant reduction of ACTD binding affinity of the heteroduplex when compared to its constituent oligomers, because the stronger-binding single strands have now been largely tied up in the duplex formation. Consequently, the duplex formation adversely affects its ACTD binding.

In view of the proposed single-strand binding, the absence of curvatures in the Scatchard plots for octamers d(CGXCGXCG) and the apparent presence of curvature in the Scatchard plots for the previously studied self-complementary octamers d(CGTCGACG) and d(CGACGTCG) may be worthy of comment. The presence of X/X mismatches in d(CGXCGXCG) dictates that at room temperature the oligomers exist predominantly in the single-stranded form that binds strongly to ACTD, thus the absence of unusual Scatchard plots. However, the self-complementary octamers d(CGTCGACG) and d(CGACGTCG) should exist predominantly in the duplex form and an ACTD-induced denaturation would be needed to provide single strands for binding and, thus, result in a curvature in the Scatchard plots with seeming binding cooperativity. The nearly identical melting temperatures of the ACTD complexes, regardless of whether they are formed with self-complementary or mismatched octamers, also appear plausible under the single-strand binding model, as the resulting complexes are similar. The huge melting temperature increases of  $\sim 45^\circ\text{C}$  upon ACTD binding to the mismatched oligomers, however, seemed rather unusual. The increase of such a magnitude would have generally corresponded to a binding affinity of at least an order of magnitude higher than the  $10^7 \text{ M}^{-1}$  obtained via our titrations. Such an argument would be correct if the dominant conformation of the DNA in the absence of drugs is the one directly involved in the drug binding. It is plausible that the conformation of d(CGXCGXCG) responsible for ACTD binding may be induced by the drug or exists initially as a minor form (thus exhibits no detectable cooperative melting temperature) rather than the dominant contributor to the DNA conformations in the absence of drugs. A quantitative correlation of the melting temperature increases with the drug binding constants will, consequently, not be as straight forward.

In contrast to the XCG addition, pentamers d(CGXCG) resulted from the removal of an XCG unit from the parent octamer exhibit more than an order of magnitude lower ACTD affinities. This suggests that in addition to the sequence and the presence of G at the 3' terminal, a minimum length of 8 bases may be essential for strong ACTD binding for oligomers with XCG motif. This appears to be consistent with the formation of intramolecular DNA conformation, such as hairpin, during the ACTD complexation. The weak bindings of hexamers d(GXCGXC) and d(CXCGXG) may thus be attributed to the shorter length and the altered sequence of the latter, and the absence of G at the 3' terminal for the former.

To further delineate the binding contributions of hairpin versus single-stranded forms, detailed NMR structural studies of ACTD complexes with d(CGTCGTCG) will be needed. These studies are currently underway at the laboratory of Dr. Shan-Ho Chou, and the results will be reported as they become available.

Research Supported by Army Medical Research Grant DAMD17-94-J-4474 and a subproject of Minority Biomedical Research Support Grant S06GM0892.

## REFERENCES

- Bailey, S. A., D. E. Graves, and R. Rill. 1994. Binding of actinomycin D to the T(G)<sub>n</sub>T motif of double-stranded DNA: determination of the guanine requirement in nonclassical, non-GpC binding sites. *Biochemistry*. 33:11493–11500.
- Chen, F.-M. 1988. Binding specificities of actinomycin D to self-complementary tetranucleotide sequences -XGCT-. *Biochemistry*. 27:6393–6397.
- Chen, F.-M. 1992. Binding specificities of actinomycin D to non-self-complementary -XGCT- tetranucleotide sequences. *Biochemistry*. 31:6223–6228.
- Chen, F.-M., and C. D. Liu. 1996. Is the strong actinomycin D binding of d(5'CGTTCGACG3') the consequence of end-stacking? *Biochemistry*. 35:7283–7291.
- Farber, S. J. 1966. Chemotherapy in the treatment of leukemia and Wilms' tumor. *J. Am. Med. Assoc.* 198:826–836.
- Fasman, G. D., editor. 1975. CRC Handbook of Biochemistry and Molecular Biology, Vol. 1, 3rd Ed. Chemical Rubber Publishing Co., Cleveland, OH. 589.
- Goodisman, J., R. Rehmann, B. Ward, and J. C. Dabrowiak. 1992. Site-specific binding constants for actinomycin D on DNA determined from footprinting studies. *Biochemistry*. 31:1046–1058.
- Hommer, R. B. 1969. The circular dichroism of actinomycin D and its complexes with DNA and dGMP5'. *Arch. Biochem. Biophys.* 129:405–407.
- Hsieh, Y. L., Y. T. Li, and J. D. Henion. 1994. Studies of non-covalent interactions of actinomycin D with single-stranded oligodeoxynucleotides by ion spray mass spectrometry and tandem mass spectrometry. *Biol. Mass Spectrom.* 116:272–276.
- Kamitori, S., and F. Takusagawa. 1992. Crystal structure of the 2:1 complex between d(GAAGCTTC) and the anticancer drug actinomycin D. *J. Mol. Biol.* 225:445–456.
- Kamitori, S., and F. Takusagawa. 1994. Multiple binding modes of anticancer drug actinomycin D: x-ray, molecular modeling, and spectroscopic studies of d(GAAGCTTC)<sub>2</sub>-actinomycin D complexes and its host DNA. *J. Am. Chem. Soc.* 116:4154–4165.
- Lewis, J. L. 1972. Chemotherapy of gestational choriocarcinoma. *Cancer*. 30:1517–1521.
- Marina, N., J. Fontanesi, L. Kun, B. Rao, J. J. Jenkins, E. I. Thompson, and E. Etcubanas. 1992. Treatment of childhood germ cell tumors. *Cancer*. 70:2568–2575.
- Nakamura, E., Y. Kaneko, J. Takenawa, and M. Sasaki. 1992. Comparative study of risk criteria for germ cell tumor. *Acta Urol. Jpn.* 38:913–918.
- Newlands, E. S., K. D. Bagshawe, R. H. J. Begent, G. J. S. Rustin, and L. B. Holden. 1991. Results with the EMA/CO (etoposide, methotrexate, actinomycin D, cyclophosphamide, vincristine) regimen in high risk gestational trophoblastic tumours, 1979 to 1989. *J. Obstet. Gynaecol.* 98:550–557.
- Rill, R. L., and K. H. Hecker. 1996. Sequence-specific actinomycin D binding to single-stranded DNA inhibits HIV reverse transcriptases and other polymerase. *Biochemistry*. 35:3525–3533.
- Rill, R. L., G. A. Marsch, and D. E. Graves. 1989. 7-Azido-actinomycin D: a photoaffinity probe of the sequence specificity of DNA binding by actinomycin D. *J. Biomol. Struct. Dyn.* 7:591–605.
- Schink, J. C., D. K. Singh, A. W. Rademaker, D. S. Miller, and J. R. Lurain. 1992. Etoposide, methotrexate, actinomycin D, cyclophosphamide, and vincristine for the treatment of metastatic, high-risk gestational trophoblastic disease roughly 0.8 mM in nucleotide. *Obstet. Gynecol.* 80:817–820.
- Scramrov, A. V., and R. Sh. Beabealashvilli. 1983. Binding of actinomycin D to DNA revealed by DNase I footprinting. *FEBS Lett.* 164:97–101.
- Snyder, J. G., N. G. Hartman, B. L. D'Estainto, O. Kennard, D. P. Remeta, and K. J. Breslauer. 1989. Binding of actinomycin D to DNA: evidence for a nonclassical high-affinity binding mode that does not require GpC sites. *Proc. Natl. Acad. Sci. USA.* 86:3968–3972.
- Sobell, H. M., and S. C. Jain. 1972. Stereochemistry of actinomycin binding to DNA. II. Detailed molecular model of actinomycin-DNA complex and its implication. *J. Mol. Biol.* 68:21–34.
- Sobell, H. M., S. C. Jain, T. D. Sakore, and C. E. Nordman. 1971. Stereochemistry of actinomycin-DNA binding. *Nature New Biol.* 231:200–205.
- Wadkins, R. M., E. A. Jares-Erijman, R. Klement, A. Rudiger, and T. M. Jovin. 1996. Actinomycin D binding to single-stranded DNA: sequence specificity and hemi-intercalation model from fluorescence and <sup>1</sup>H NMR spectroscopy. *J. Mol. Biol.* 262:53–68.
- Wadkins, R. M., and T. M. Jovin. 1991. Actinomycin D and 7-aminoactinomycin D binding to single-stranded DNA. *Biochemistry*. 30:9469–9478.
- Wadkins, R. M., B. Vladu, and C.-S. Tung. 1998. Actinomycin D binds to metastable hairpins in single-stranded DNA. *Biochemistry*. 37:11915–11923.