

## BEHAVIORAL ENGINEERING: TWO APPARATUSES FOR TOILET TRAINING RETARDED CHILDREN<sup>1</sup>

N. H. AZRIN, C. BUGLE, AND F. O'BRIEN

ANNA STATE HOSPITAL

Daytime incontinence is a major problem for retarded children. A training procedure for eliminating this problem should be facilitated by an apparatus that provided the trainer with an immediate signal when the child voided so that the trainer could react immediately. Two apparatuses were developed for this purpose: a toilet-chair apparatus to signal proper toileting and a portable pants-alarm apparatus to signal wetting of the pants. A reprimand was given when pants wetting occurred whereas positive reinforcement was given for proper toileting. Results with four profoundly retarded children indicated the reliability of the apparatuses in practice and the effectiveness of a toilet training program that used the two apparatuses.

Nocturnal incontinence of normal children has received extensive study as a result of which effective treatments based on conditioning procedures have been developed (Mowrer and Mowrer, 1938), refined, and systematically evaluated (see review by Lovibond, 1964). Daytime incontinence apparently has not been a major problem for normal children. For the retarded child, however, daytime incontinence causes major economic concern and personnel time to custodial institutions. Of even greater importance is the humane consideration that the mentally retarded should not be obliged to live in their own waste. Only recently have reinforcement procedures been described for toilet training profound retardates. These procedures have included positive reinforcement for toileting in the appropriate location, Hundziak, Maurer, and Watson (1965), Giles and Wolf (1966), Bensberg (1965), Van Wagenen, Meyerson, Kerr, and Mahoney (1969) and a negative consequence, a reprimand, for voiding in one's clothing (Van Wagenen *et al.*, 1969). These two procedures should be more effective if an apparatus were available to provide an immediate signal for the eliminatory responses so that the parent or trainer could provide consequences immediately. A

somewhat complex apparatus for detecting pants-wetting has been developed by Van Wagenen and Murdock (1966) and used effectively with normals (Madsen *et al.*, 1969) and retardates (Van Wagenen *et al.*, 1969). A complex photoelectric apparatus for signaling correct toileting by retardates has been described by Watson (1968) but no data given regarding its reliability or effectiveness. The present report describes two other apparatuses that seemed simpler in design, more foolproof, and more economical than the previously described apparatuses.

### METHOD

#### *Pants-Alarm Apparatus*

Figure 1 (top) is a representation of the pants-alarm apparatus. No special pants were needed. Rather, two ordinary metal clothing snaps (size 16, male) were fastened to ordinary cotton briefs in the area of the crotch and spaced about 1.5 in. (4 cm) apart using a commonly available device for attaching snap fasteners to clothing. The two male snaps were connected by female snaps (Nu-Way snaps available from Burstein-Applebee, Kansas City, Missouri) to a flexible #20-gauge insulated wire leading to the circuit box worn by the child on a belt beneath the outer blouse or dress. Neither the wires nor the small (8 by 5 by 2 cm) and lightweight (4 oz) circuit box was visible. Figure 2 (top) is a schematic of the electrical circuit in the circuit box. When urine moistened the pants, the decreased electrical resistance between

<sup>1</sup>This research was supported by the State of Illinois Department of Mental Health and by Grant MH-17981 from the National Institute of Mental Health. Reprints may be obtained from N. H. Azrin, Behavior Research Laboratory, Anna State Hospital, Anna, Illinois 62906.

## WET-ALARM PANTS

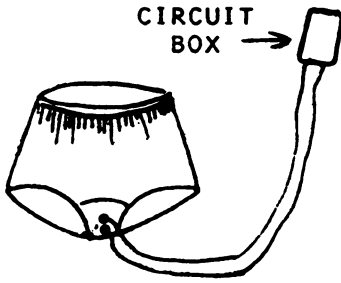

## MOISTURE DETECTING SNAPS

## TOILET-SIGNAL CHAIR

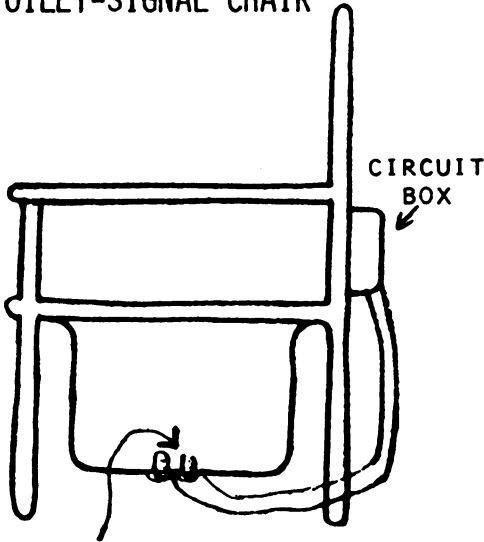

## MOISTURE DETECTING STUDS

Fig. 1. Wet-alarm pants for toilet training—upper figure. The pants are ordinary cotton training pants. Two ordinary clothing snap fasteners are attached to the crotch area. Snap leads connect the snaps to the circuit box, which is worn on a belt on the waist. The circuit box contains an alarm that sounds when urine moistens the cloth between the two snaps. Dry pants are substituted for wet ones by simply pulling the snap leads off the wet pants and snapping them on the snaps of the dry replacement pants. Toilet-alarm chair for toilet training—bottom figure. Side view of the apparatus for immediately signalling urination or defecation. The chair is a commercially available “potty” chair. Two studs are attached to the bottom of the “potty”. Manually connected snap leads connect the studs to the circuit box which is fixed to the back of the chair. A speaker in the circuit box gives an immediate signal when urine or feces falls into the “potty”.

the two snaps completed the low voltage circuit and the pants alarm sounded. The electrical current flow was too slight to be detected or felt by the child. The alarm was a bleep-tone of about 2500 Hz and could be heard easily above the usual noise on a ward. The total cost of all components including the sounding device was about \$10.

*Toilet Signal Apparatus*

Figure 1 (bottom) is a representation of the toilet-signal apparatus. No special chair was needed. Rather, a standard children's toilet chair, costing about \$5 was used that had a standard plastic “potty” container beneath the seat rest. Two male snap studs were fastened to the bottom center of the container about 0.5 in. (1 cm) apart. The small (8 by 5 by 2 cm) signal package was fastened to the back support of the chair and was connected to the two metal studs by female snaps attached to insulated wire leads. When the child urinated into the “potty”, the moisture completed a low voltage circuit, see Fig. 2 (bottom), between the metal studs and produced a clicking sound from a speaker in the circuit box. The sound was qualitatively different from that generated by the pants-alarm and could also be heard easily at a distance. The total cost of all components, excluding the \$5 chair, was about \$10<sup>2</sup>. A modification of this apparatus for use in a regular toilet bowl is described by Azrin and Foxx (1971).

*Subjects*

Four profoundly retarded females aged 3, 5, 6, and 6 yr were the subjects. The 3-yr old child had Hurler's syndrome. All were non-verbal, retarded from birth, had been resistant to previous intensive toilet training efforts, did not learn to dress or feed themselves without intensive training, did not play with other children, and had locomotor deficits. The two 6-yr olds had visual deficits and were treated in a day-care center. The 3 and 5-yr old children were institutionalized in a special facility for retarded children. The IQs of the two 6-yr olds were too low to produce a score on the Stanford-Binet test administered by an in-

<sup>2</sup>We have been informed by Lehigh Valley Electronics, Inc. that they can supply both of the apparatuses described here at an individual cost of about \$40; address Box 125, Fogelsville, Pennsylvania 18051.

## WET-ALARM PANTS CIRCUIT

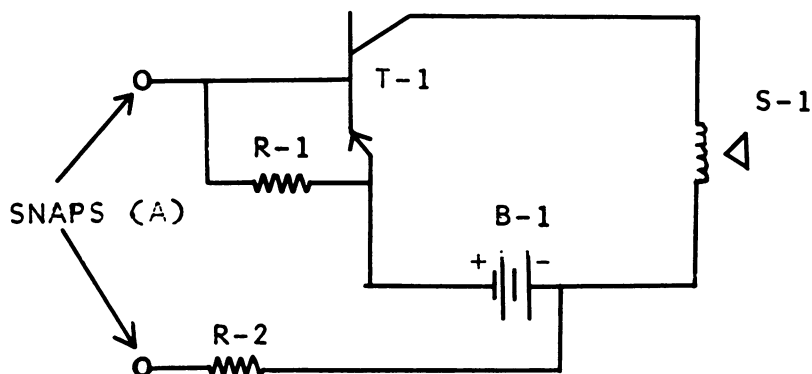

## TOILET-SIGNAL CHAIR CIRCUIT

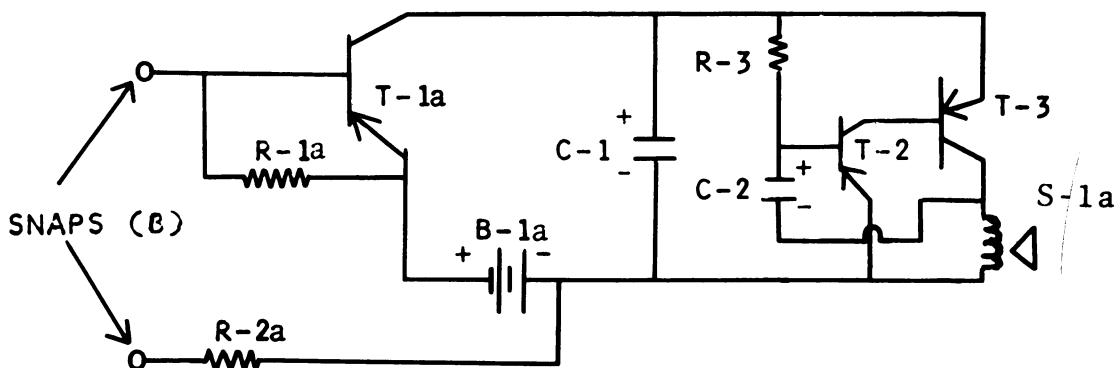

Fig. 2. Schematic of wet-alarm pants circuit (top) and toilet-signal chair circuit (bottom); component identifications are as follows: R-1 and R-1a, 100 ohm,  $\frac{1}{8}$  watt resistor; R-2 and R-2a, 15,000 ohm,  $\frac{1}{8}$  watt resistor; R-3, 22,000 ohm,  $\frac{1}{8}$  watt resistor; C-1, 100 mfd capacitor, 15 volts; C-2, 2.2 mfd capacitor, 15 volt; T-1, T-1a and T-3, transistor #GE-2; T-2, transistor #GE-7; S-1, "Bleep-tone" signal tone device available from C. A. Briggs Company, Glenside, Pa. S-1a, speaker, 1.5 in., 0.1 watt, 8 ohm; B-1 and B-1a Battery, Eveready #216, 9 volt, or equivalent; Snaps: Nu-Way available from Burstein-Applebee Co., Kansas City, Missouri. The A-Snaps attach to matching snaps on the training pants; the B-Snaps attach to matching studs on the toilet chair.

dependent testing agency. IQs were not available for the other two children.

#### Procedure

The apparatuses were used as part of a toilet training program for two to four months with the two children in the day-care program. The baseline frequency of wetting for these two children was 10 and seven pants-wettings per day. During training, many changes were made in the apparatus, the consequences for urinating, the toileting schedule, *etc.* in an effort to develop an effective program. By the end of the training, both

children ceased wetting their pants almost entirely, averaging less than once per week. They continued to be dry after the training was discontinued.

The final procedure developed with the first two children was then applied to the two institutionalized children. A baseline record of incontinence was obtained for at least two weeks, during which the child wore the pants-alarm apparatus (inoperative) and was placed on the toilet chair (also inoperative) for 5 min at 2-hr intervals such as might be normal toileting routine in an institution. After the 2-wk baseline, the training proce-

cedure was initiated and the two apparatuses were made operative: the pants alarm sounded and the toilet-signal clicked when wet. The child was required to drink a glass of water every half-hour to increase the natural frequency of urination; similarly, Giles and Wolf (1966) used laxatives to increase bowel movements. The scheduled toilet periods were changed from the baseline frequency of one every 2 hr to one every half-hour to provide more opportunity for the child to urinate in the toilet-chair. The teacher immediately praised and hugged the child and gave the child a bit of candy upon hearing the signal caused by the child urinating in the toilet chair. When the child urinated in her pants, the alarm sounded, whereupon the teacher gave her a single spank on the buttocks and then arranged a timeout from positive reinforcement by not interacting with her for 10 min.

Both children required training to eliminate unassisted in the toilet chair. For one of the children, instructions were sufficient for the child to lower her pants, sit on the chair and dress herself afterward. Manual guidance and verbal approval was used to train the second child to dress and undress herself. In both instances, the trainer faded out the assistance until the child toileted herself with no need for manual guidance or verbal or gestural instructions.

### Recording

The children's pants were inspected by having a specifically assigned attendant feel the pants at each of the regular toileting periods which occurred every 2 hr before and after training and every half-hour during training. A second adult was available to serve as an alternate or assistant, thereby providing additional assurance of the recording. Additional confirmation and assurance was provided by the experimenter who directly observed the procedure for about 2 hr per day on more than half of the days on an irregular basis for the first child and every day for the second child. These supervisory checks revealed that the procedure and recording were being conducted appropriately and consistently. The adults also recorded any instances of wetting between the scheduled check periods. All instances of wetting were recorded in writing at that moment on special forms.

## RESULTS

Figure 3 (upper) shows that the toilet training procedure reduced the number of wet pants per day for the child from about four per day during the baseline to near zero after three days of training. The effect was, however, reversible; wetting returned slightly when training was prematurely discontinued. When toilet training was reinstated, the child ceased wetting and remained dry thereafter.

A similar training program using the same two apparatuses was tested with an additional child. Figure 3 (lower) shows that the second

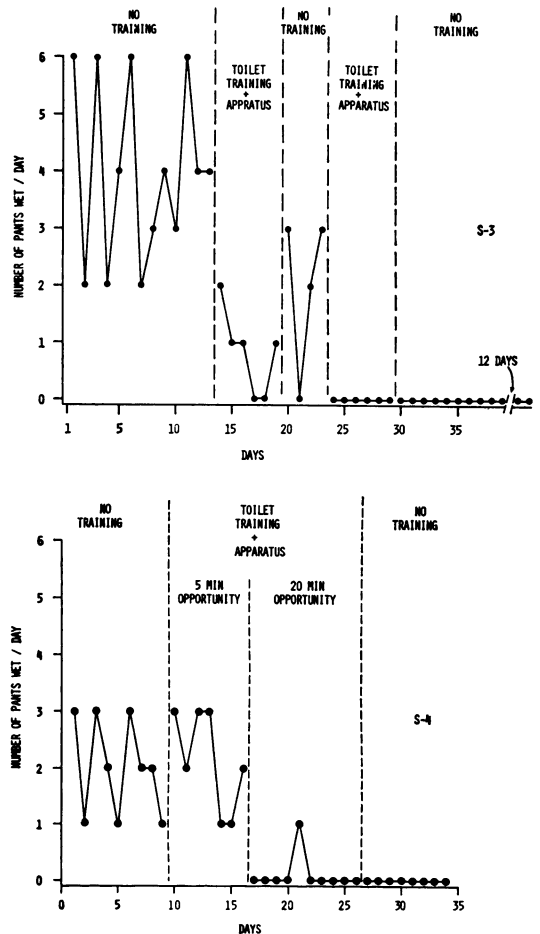

Fig. 3. The number of times that two profoundly retarded children wet their pants during a 6-hr period each day. Toilet training utilized a wet-alarm pants apparatus and a toilet-signal chair apparatus. For S-3 (upper), at regular intervals the child was given 5 min to eliminate in the toilet chair. For S-4 (lower), the 5-min interval was in effect during the first seven days of training but was then extended to 20 min.

child was wet about two times daily before training. This level was not reduced during initial training. The child almost completely ceased wetting, however, when the procedure was changed such that the child was given up to 20 min to eliminate in the chair rather than the previous 5 min. Following training, the child remained dry for the eight remaining days of the study.

Some problems were presented by the apparatuses initially, but were solved. False positives (the alarm sounding when no wetting had occurred) were never present with the toilet-chair apparatus. For the pants alarm, false positives did result when the exposed parts of the snaps on the pants touched each other. This was solved by (1) spacing the snaps 1.5 in. (3.7 cm) apart and arranging one in front and the other behind rather than side by side; (2) by covering the top of the snap with insulating paint or plastic, and, (3) using the resistance values shown in Fig. 2 so that ordinary perspiration would not activate the alarm. False negatives (alarm not sounding when wetting had occurred) were not a problem for the toilet chair except that one child occasionally excreted only a few drops, which was insufficient to activate the circuit, until a plastic funnel was substituted for the pot and the electrodes were located at the bottom narrow portion of the funnel. False negatives for the pants alarm resulted from breaking of the connecting wires and low battery voltage. The wire breakage problem was solved by using standard 20-gauge wire; the battery voltage problem was solved simply by changing batteries every two months since the circuits were designed for minimal current drain. A search for false negatives was systematically conducted by examining the children's pants at each scheduled toilet period as well as other times. No instance of false positive or false negative occurred for either apparatus during the last month of use.

#### DISCUSSION

The pants alarm apparatus differs from the apparatus described by Van Wagenen and Murdock (1966) in that no special sensing electrode grid need be sewn into the pants and no special laundering is needed to protect the electrode sensors. No reliability or cost comparison can be made because that information was not given for the other apparatus.

The report of the photoelectric apparatus (Watson, 1968) also gave no information about reliability or cost. In addition, fairly elaborate precautions were needed to prevent the patients who used that apparatus from artifactually interrupting the light beams.

The usefulness of the present apparatuses seemed to be in (1) the freedom they permitted the trainer to attend to other tasks until the alarm sounded, rather than continuously watching the children for signs of wetting, (2) the immediacy with which they permitted consequences to be delivered, (3) their reliability and maintenance-free operation, (4) their low cost of about \$10 each, and, (5) their potential application to early toilet training of normal children (one recent such attempt was effective after 10 hr of training over a 3-day period).

#### REFERENCES

- Azrin, N. H. and Foxx, R. M. A rapid method of toilet training the institutionalized retarded. *Journal of Applied Behavior Analysis*, 1971, 4, 89-99.
- Bensberg, G. J. *Teaching the mentally retarded, a handbook for ward personnel*. Atlanta: Southern Regional Education Board, 1965.
- Giles, D. K. and Wolf, M. M. Toilet training institutionalized, severe retardates: an application of behavior modification techniques. *American Journal of Mental Deficiency*, 1966, 70, 766-780.
- Hundziak, M., Maurer, R. A., and Watson, L. S. Operant conditioning in toilet training severely mentally retarded boys. *American Journal of Mental Deficiency*, 1965, 70, 120-124.
- Lovibond, S. H. *Conditioning and enuresis*. New York: The Macmillan Co., 1964.
- Madsen, C. H., Hoffman, M., Thomas, D. R., Koropsak, E., and Madsen, C. K. Comparisons of toilet training techniques. In D. M. Gilfond (Ed.), *Social learning in childhood*. Belmont: Brooks/Cole, 1969. Pp. 124-132.
- Mowrer, O. H. and Mowrer, W. M. Enuresis: a method for its study and treatment. *American Journal of Orthopsychiatry*, 1938, 8, 436-459.
- Van Wagenen, R. K., Meyerson, L., Kerr, N. J., and Mahoney, K. Field trials of a new procedure for toilet training. *Journal of Experimental Child Psychology*, 1969, 8, 147-159.
- Van Wagenen, R. K. and Murdock, E. E. A transistorized signal-package for toilet training of infants. *Journal of Experimental Child Psychology*, 1966, 3, 312-314.
- Watson, L. S., Jr. Application of behavior-shaping devices to training severely and profoundly mentally retarded children in an institutional setting. *Mental Retardation*, 1968, 6, 21-23.

Received 7 October 1970.

(Revised 30 June 1971.)