

NITELLA FLUCTUATION AND INSTABILITY IN THE MEMBRANE POTENTIAL NEAR THRESHOLD

HATSUO HAYASHI AND KAZUYOSHI HIRAKAWA, *Department of Electronics, Kyushu University, Fukuoka 812, Japan*

ABSTRACT Excitation in *Nitella* internodal cell was investigated as an example of the phase transition in an open system far from thermal equilibrium. The power density spectrum of the membrane potential fluctuation had a bulge in a frequency range lower than 1 Hz at the resting state and a peak at ~ 0.03 Hz at a depolarized state near the threshold. A critical oscillation in the membrane potential was observed when threshold was gradually approached from the resting state. Repetitive firing was observed under a step-current of the superthreshold value. The frequency of spectral peaking, critical oscillation, and repetitive firing agree well with each other. The result suggests that the hard-mode instability occurs in the *Nitella* internodal cell. The membrane impedance had no peak in the same frequency region as the peak of the voltage spectrum. The spectral peak may be ascribed to the electrogenic pump modulated by the metabolic feedback system in photosynthesis.

INTRODUCTION

Excitation in biological membranes may be viewed as a phase transition in an open system far from thermal equilibrium (Aizawa and Kobatake, 1974; Kobatake et al., 1975). The fluctuation around the mean behavior of a system is associated with the probabilistic mechanism of the underlying microscopic process (Stevens, 1972) and influences macroscopic behavior when the system becomes unstable near its critical point (Nicolis and Prigogine, 1977).

Internal perfusion with a dilute solution of cesium salt causes a macroscopic fluctuation in the membrane potential of a squid axon near the critical value of the external $\text{Na}^+/\text{Ca}^{2+}$ concentration ratio (Inoue et al., 1973). There is no K^+ in the internal medium and the duration of the action potential is ~ 5 s, approximately 10^3 times longer than the intact squid axon. Self-sustained repetitive firing has been induced in the intact squid axon by exchanging sea water for a 1:4 mixture of sea water and 550 mM NaCl (Matsumoto et al., 1978; Matsumoto and Kunisawa, 1978). Macroscopic fluctuation and repetitive firing have been explained by postulating an onset of the hard-mode instability and subsequent time-ordered structure. This instability has been observed when the environment around the axon is different from its normal condition.

In the intact squid axon, Inoue et al. (1973) failed to demonstrate macroscopic fluctuations near the critical $\text{Na}^+/\text{Ca}^{2+}$ concentration ratio because of the rapidity of the relaxation process after a transition. The repetitive firing is not always observed in the intact squid axon bathed in normal sea water but is low Ca^{2+} or Mg^{2+} -free artificial sea water (Hagiwara and Oomura, 1958; Stein, 1967; Guttman and Barnhill, 1970; Adelman and Fitzhugh, 1975). In *Nitella* internodal cells, it has been observed in artificial pond water (APW) that oscillatory potential fluctuation occurs near threshold when the threshold is gradually approached from

the resting state and the power density spectrum of membrane potential fluctuation has a peak at a depolarized state near threshold (Hayashi and Hirakawa, 1979). Since the action potential of an intact *Nitella* internode in APW is $\sim 10^3$ times as long as that of the intact squid axon in sea water, it is expected that the relaxation times of the elementary processes of the *Nitella* internode are long enough to investigate the critical phenomena accompanying excitation in APW.

The power density spectrum of the membrane current fluctuation observed under the voltage clamp condition has two components. One is the $1/f$ spectrum attributed to passive processes such as ion-diffusion in channels or leakage pathways (Poussart, 1971). $1/f$ -noise has also been observed in synthetic membranes (DeFelice and Michalides, 1972). The other is the Lorentzian spectrum corresponding to the conductance fluctuation arising from the relaxation processes of channels implicit in the Hodgkin-Huxley (H-H) model (Hodgkin and Huxley, 1952; Stevens, 1972; Hill and Chen, 1972). A Lorentzian spectrum, $f_c^{-1} [1 + (f/f_c)^2]^{-1}$, corresponding to the K^+ conductance fluctuation has been observed in the squid giant axon; $f_c = (2\pi\tau_K)^{-1}$ and τ_K is the H-H relaxation time for the K^+ -channel (Fishman, 1973; Conti et al., 1975; Fishman et al., 1975b).

A steady-state model has been proposed for a Lorentzian spectrum that peaks at frequencies other than zero (Chen, 1975). This model is useful for identifying a non-equilibrium steady state (Chen, 1978). The fluctuation near the hard-mode instability (see Discussion for a definition) point in the non-equilibrium system has also been studied (Tomita and Tomita, 1974).

The present paper suggests that a hard-mode instability exists near the threshold of *Nitella* internodal cells, as evidenced by three observations in APW: (a) peaking in the power density spectrum of the membrane potential fluctuation at a depolarized state near threshold, (b) critical oscillation in the membrane potential when the threshold is gradually approached from the resting state, and (c) repetitive firing under a superthreshold step-current stimulation or a ramp-current stimulation.

The membrane impedance had no resonance in the same frequency region as the peak of the noise spectrum. It seems unlikely that the spectral peak is attributable to the fluctuation of channels because there is no impedance resonance. The spectral peak may be ascribed to the electrogenic pump modulated by the metabolic feedback system in photosynthesis. Details will be discussed.

MATERIALS AND METHODS

Nitella axilliformis was cultured in the 0.5% Knop solution at 26–28°C. The internodal cells of *Nitella*, $\sim 300 \mu\text{m}$ diam and 2 cm long, were isolated from neighboring cells and stored in APW for at least 1 d. The APW was composed of 0.05 mM KCl, 0.05 mM NaH_2PO_4 , 0.2 mM NaCl, 0.1 mM MgSO_4 , and 0.1 mM $\text{Ca}(\text{NO}_3)_2$; pH 5.6.

A diagram of the measuring system is shown in Fig. 1. The polyacrylate measuring chamber, C, has two pools, A and B, separated by the 2-mm long wall. The internodal cell, N, was placed in a narrow channel, d, ~ 2 mm wide, connecting pools A and B. Vaseline, W, covered part of the internodal cell in d to provide electrical insulation. Both pools A and B were filled with APW, exchangeable with fresh APW through inlet a (a') and outlet b (b'). The stimulating current was applied by Ag-wires, S₁ and S₂. The current density flowing through the membrane was estimated from the surface area of the cell in pool A and the current calculated from the potential drop across a resistor R₁ (500 k Ω).

The membrane potential was detected with a microelectrode, M, inserted into the vacuole. The

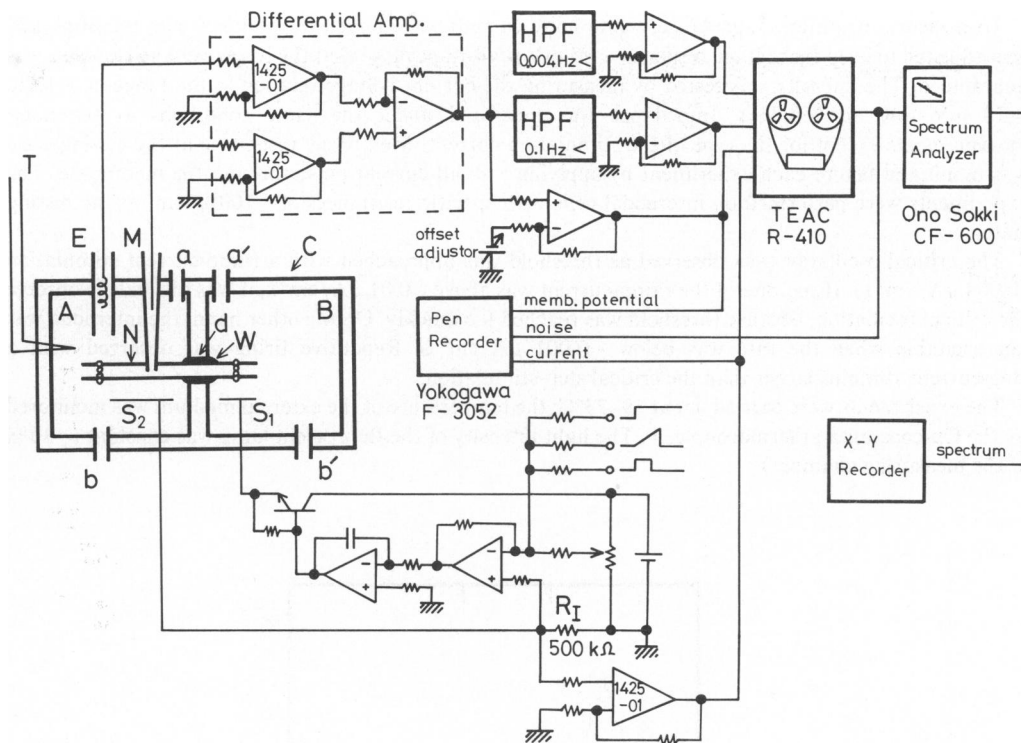

FIGURE 1 A diagram of the measuring system. C is the chamber which consists of two pools, A and B; d, the channel; N, Nitella internodal cell; W, vaseline; a, a', inlet; b, b', outlet; S₁, S₂, Ag-wires; M, Ag-AgCl glass microelectrode; E, reference electrode; and T, Cu-constantan thermocouple.

microelectrode was an Ag-AgCl glass microtip filled with 3 M KCl having a resistance of $\sim 2 \text{ M}\Omega$. The reference electrode, E, was an Ag-AgCl electrode filled with 0.05 M KCl-agar (0.7 mm diam; $\sim 200 \text{ K}\Omega$). The potential difference between the electrodes M and E was measured with a high input impedance ($10^7 \Omega$) differential amplifier (Teledyne Philbrick, Dedham, Mass.; model 1425-01). The offset potential given by the electrodes M and E was adjusted to zero before inserting M into the internodal cell. In the present experiments, the current clamp method was adopted.

When the internodal cell A was depolarized, part of the internode in the pool B was hyperpolarized; internode B length was made as short as possible ($\sim 3 \text{ mm}$) to diminish the hyperpolarized region. The inhomogeneity of the current density through the membrane was ignored because the vacuolar resistance, $\sim 100 \text{ k}\Omega$, was much smaller than the membrane resistance, $\sim 1 \text{ M}\Omega$, in the internode A, which was $300 \mu\text{m}$ diam and 1.5 cm long. The chamber, the exchanging solutions, the microscope, and the preamplifier were set in a metal cage for electromagnetic shielding.

After preamplification with a differential amplifier, the noise signal was further amplified through two high-pass filters with low-frequency cutoffs (0.004 Hz:48 dB/oct and 0.1 Hz:12 dB/oct) to increase the dynamic range and to exclude DC and low-frequency range in the spectral analyses. The noise wave forms were recorded in the data recorder (TEAC, Musashino, Tokyo, Japan; model R-410). Spectral analysis of the noise was performed in three overlapping frequency bands (0.002 \sim 1 Hz, 0.02 \sim 10 Hz, and 0.2 \sim 100 Hz). The lowest frequency in each band corresponds to the band resolution (500 points). The playing tape speed of the data recorder was 100 times as fast as the recording speed; three bands (0.2 \sim 100 Hz, 2 \sim 1000 Hz, and 20 \sim 10000 Hz) were used in the spectral analyzer (Ono Sokki, Yaguchi, Ota-ku, Tokyo, Japan; model CF-600). Power spectra were obtained by averaging 16 spectra in the lowest band, 128 spectra in the middle band, and 256 spectra in the highest band.

To measure membrane impedance, white noise current was applied to the internode. Its amplitude was adjusted to keep the voltage response $< \pm 5$ mV peak-to-peak, so that the linear voltage response was guaranteed. The linearity was tested by measuring the current-voltage relation in the range of -10 to $+20$ mV (DC or 0.1 Hz). Impedance was measured under the same conditions as the noise measurements except for the type of the stimulating current. Membrane resistance at the resting state was monitored before each experiment by applying a small current pulse through the membrane. The experiments were performed on internodal cells with specific resistances of ~ 100 k Ω cm 2 at the resting state.

The critical oscillation was observed as threshold was approached with a ramp-current stimulation (0.004 μ A/cm 2 s). If the rate of the ramp-current was above ~ 0.01 μ A/cm 2 s, it was difficult to observe the critical oscillation, because threshold was reached too quickly. On the other hand, the internode was not excitable when the rate was below ~ 0.001 μ A/cm 2 s. Repetitive firing was observed with a step-current stimulus larger than the critical step-stimulation.

The experiments were carried out at 19 – 23° C; the temperature of the external medium was monitored by the Cu-constantan thermocouple, T. The light intensity of the fluorescent lamp was constant (~ 30 lx at the measuring chamber).

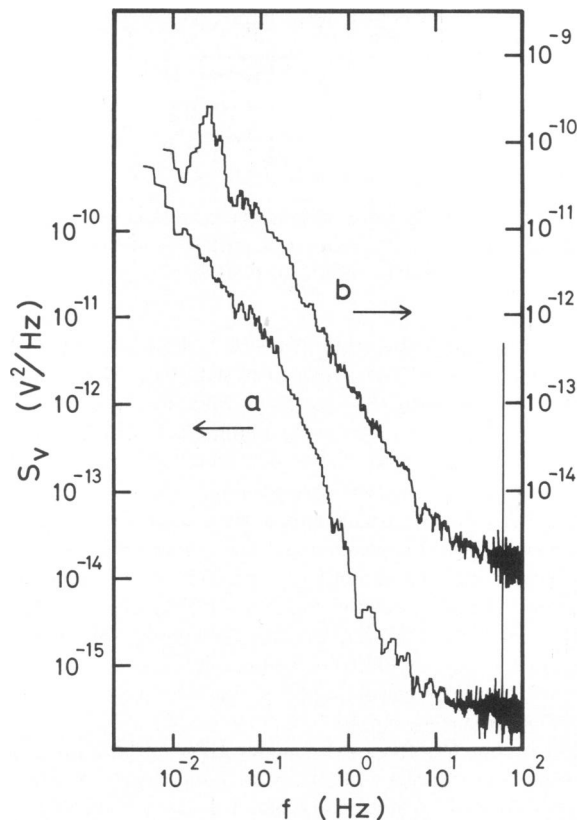

FIGURE 2 The power density spectra of the membrane potential fluctuation. The spectra *a* and *b* were obtained at the resting state (-130 mV) and a depolarized state (-94 mV) near the threshold potential (-90 mV), respectively. Note the different scales for *a* and *b*.

RESULTS

Power Density Spectrum of the Membrane Potential Fluctuation

The power density spectra of the membrane potential fluctuation of the *Nitella* internodal cell are shown in Fig. 2. Spectrum *a* was obtained at the resting state (-130 mV) and has a bulge in the frequency range lower than 1 Hz. Spectrum *b* shows the result near the threshold potential (-90 mV) and clearly demonstrates peaking at ~ 0.03 Hz. The spectra near the threshold potential were measured ten times in five internodal cells; peaking was observed six times in four cells. The average value of peaking frequency was 0.030 Hz. The data are summarized in Table I.

The resting vacuolar potential and the threshold of the internodal cells used in these experiments lay between -122 and -175 mV and between -82 and -109 mV in APW, respectively.

In the *Nitella* internodal cell it is widely accepted that the increase in Cl^- and K^+ conductance gives rise to the action potential and that the relaxation time of the K^+ -channel is greater than that of the Cl^- -channel (Gaffey and Mullins, 1958; Mullins, 1962; Hope and Findlay, 1964; Kishimoto, 1964; Mailman and Mullins, 1966; Oda, 1975, 1976). However, there is little experimental data on the relaxation time of these channels. The action potential has a half-width of ~ 600 ms and a tail far longer than a few seconds, as shown in Fig. 3. The relaxation time of the K^+ -channel is estimated to be greater than 2 s ($f_c^K < 0.08$ Hz); the Cl^- -channel is < 200 ms ($f_c^{\text{Cl}} > 0.08$ Hz). The bulge in spectrum *a* shown in Fig. 2 may be attributed to the relaxation process of the K^+ -channel, but it is difficult to identify the K^+ conductance fluctuation because no blocking agent for Cl^- - or K^+ -channels of *Nitella* has been found.

TABLE I
FREQUENCIES OF SPECTRAL PEAKS, CRITICAL OSCILLATIONS, AND REPETITIVE FIRINGS, AND FREQUENCY REGIONS WHERE THE IMPEDANCE IS FLAT

Cell no.	Spectral peak	Critical oscillation	Repetitive firing (step-current)	Repetitive firing (ramp-current)	$ Z ^2$	
					Rest	Near threshold
(Hertz)						
1	—	0.032 (2)	—	—	—	—
2	—	0.041 (4)	—	—	—	—
3	0.025 (2)	—	—	—	—	—
4	—	0.049 (3)	0.031 (3)	0.054 (1)	—	—
5	—	—	—	—	0.008–0.3 (1)	0.008–0.8 (1)
6	—	—	0.031 (2)	0.035 (1)	0.008–0.4 (1)	0.008–2.5 (1)
7	0.028 (2)	—	—	—	0.008–0.3 (1)	—
8	0.040 (1)	—	0.064 (2)	0.047 (1)	0.008–0.7 (1)	0.008–2.0 (1)
9	0.027 (1)	0.032 (4)	0.043 (3)	0.042 (1)	0.008–0.4 (1)	0.008–1.0 (1)
Average	0.030	0.039	0.042	0.045	0.008–0.4	0.008–1.6

The number of the observation is shown in the parentheses. The frequency region where the impedance is flat is shown in the column of $|Z|^2$. Bars indicate that experiments were not done.

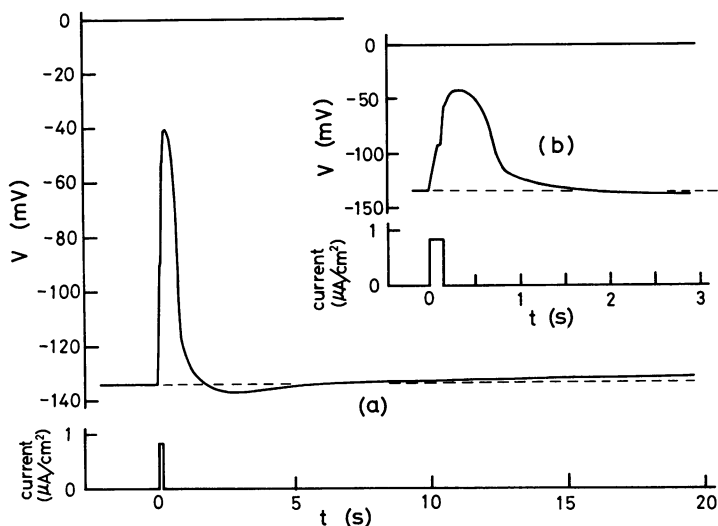

FIGURE 3 The action potential observed with the pulse current stimulation; 150 ms wide and $0.75 \mu\text{A}/\text{cm}^2$ high. Note that the time scale is elongated in *b*.

Membrane Impedance

The power density spectrum of the fluctuation in the membrane potential under a current clamp condition is given by (Stevens, 1972)

$$S_v(f) = |Z(f)|^2 S_I(f), \quad (1)$$

where $S_v(f)$ and $S_I(f)$ are the spectra for potential and current fluctuations and $Z(f)$ is the membrane impedance. The measurement of the membrane impedance must be known to calculate conductance fluctuations from potential fluctuation measurements.

The square of the membrane impedance of the same *Nitella* internodal cell as used for measurement of the power spectra (Fig. 2) is shown in Fig. 4. The impedance is constant between 0.008 and 1 Hz. There is no resonance at the resting state (*a*) (-132 mV) or the depolarized state (*b*) (-104 mV). The voltage spectrum of the potential fluctuation is not affected by the membrane impedance and directly reflects the spectrum of conductance fluctuation in the frequency range lower than 1 Hz. Spectral peaking in Fig. 2 *b* cannot be explained by the impedance. The frequency regions where the impedance is flat are summarized in Table I.

Critical Oscillation of the Membrane Potential near the Threshold

Ramp-current stimulation was used to observe the development of the oscillatory potential fluctuation as threshold is approached. Fig. 5 shows the fluctuation in the membrane potential (*a*) and the variation of the potential under ramp-current stimulation (*b*). The amplitude of the fluctuation increases as the threshold is approached, and the oscillatory fluctuation is apparent near threshold. This critical fluctuation near threshold was observed 13 times in four cells. The averaged frequency of these oscillations is 0.039 Hz, slightly higher than the peak frequency in the power spectrum. These data are summarized in Table I.

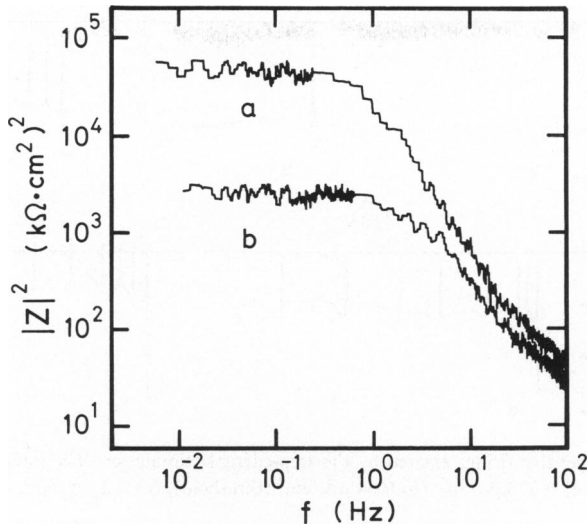

FIGURE 4 The frequency dependences of the square of the membrane impedances at the resting (-132 mV)(a) and at the depolarized (-104 mV)(b) states. The threshold potential was -98 mV. The internodal cell is the same one as used for measurement of the power spectra (Fig. 2).

Repetitive Firing

When constant currents of various intensities were applied to the *Nitella* internodal cell, the cell fired repetitively in APW (Fig. 6). The squid axon does not always fire repetitively in normal sea water, but does so in low Ca^{2+} or Mg^{2+} -free artificial sea water (Hagiwara and Oomura, 1958; Stein, 1967; Guttman and Barnhill, 1970; Adelman and Fitzhugh, 1975).

The frequency of repetitive firing in the *Nitella* internodal cell is $\sim 10^4$ times lower than that

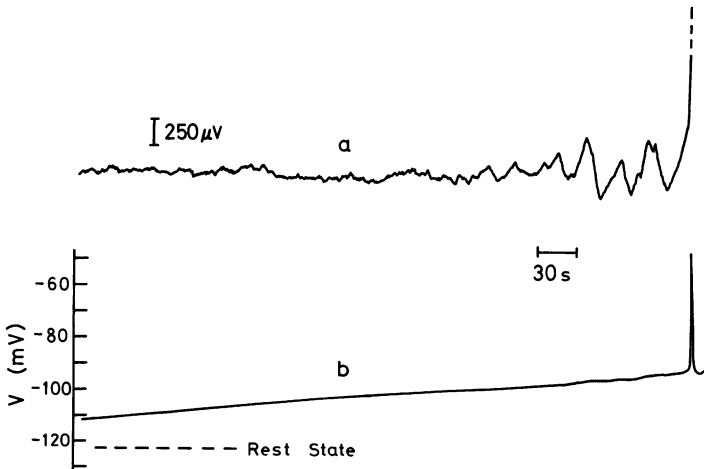

FIGURE 5 The critical oscillation in the membrane potential. (a) The fluctuation and the critical oscillation observed through the high pass filter. (b) The variation of the membrane potential under the ramp-current stimulation ($0.004 \mu\text{A}/\text{cm}^2 \text{ s}$).

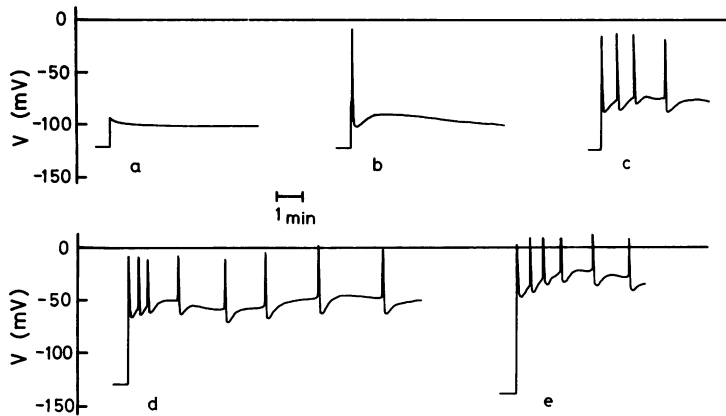

FIGURE 6 The repetitive firings excited by the step-current stimulation. The intensities of the current stimulations were (a) $0.32 \mu\text{A}/\text{cm}^2$, (b) $0.64 \mu\text{A}/\text{cm}^2$ (threshold), (c) $2.2 \mu\text{A}/\text{cm}^2$, (d) $5.1 \mu\text{A}/\text{cm}^2$, and (e) $7.6 \mu\text{A}/\text{cm}^2$.

of the squid axon, but their characteristic features are similar. A single action potential could be excited by a step-current of $\sim 0.7 \mu\text{A}/\text{cm}^2$; repetitive firing requires a somewhat higher step-current than threshold. The frequency of repetitive firing increased slightly with the stimulus intensity, and trains of spikes halted in finite sequence.

The frequency of repetitive firing was measured using the intervals between the first two or three spikes excited by a superthreshold current larger than $3.5 \mu\text{A}/\text{cm}^2$. These are summarized in Table I. The average value, 0.042 Hz, agrees well with the average frequency of the critical oscillation and the peaking in the power spectrum described above.

Repetitive firing in the *Nitella* internodal cell was also excited by the ramp-current stimulation. As shown in Fig. 7, the frequency of repetitive firing increased with the rate of the ramp-current. In the train of spikes observed at a slow rate, the subthreshold response (the critical oscillation) was frequently intermixed with spikes. The frequencies measured using

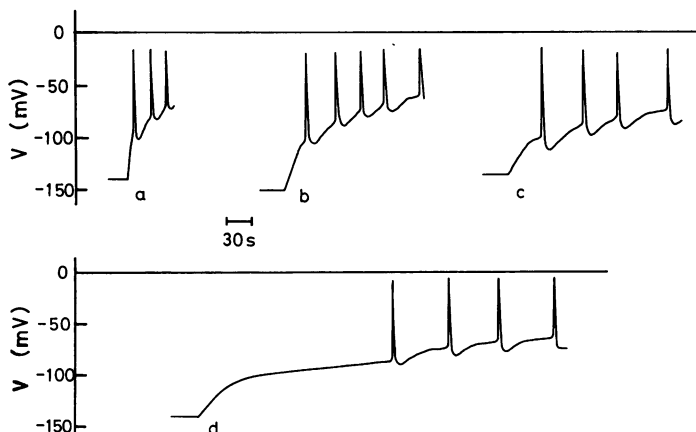

FIGURE 7 The repetitive firings excited by the ramp-current stimulations. The rates of the ramp-current stimulations were (a) $0.071 \mu\text{A}/\text{cm}^2 \text{ s}$, (b) $0.022 \mu\text{A}/\text{cm}^2 \text{ s}$, (c) $0.015 \mu\text{A}/\text{cm}^2 \text{ s}$, and (d) $0.008 \mu\text{A}/\text{cm}^2 \text{ s}$.

the intervals between the first two or three spikes and observed at the rate faster than 0.03 $\mu\text{A}/\text{cm}^2$ s are also summarized in Table I; the average value was 0.046 Hz.

DISCUSSION

The theoretical power density spectrum of the conductance fluctuation in the K^+ -channel with discrete states has been derived on the basis of the statistical interpretation of the H-H equations (Hill and Chen, 1972; Stevens, 1972; Chen and Hill, 1973). The spectrum is the sum of Lorentzian components:

$$S(f) = \sum_{i=1}^x M_i f_i^{-1} [1 + (f/f_i)^2]^{-1}, \quad (2)$$

where $f_i = i/2\pi\tau_n$ and M_i is a constant depending on i and the membrane potential. τ_n and x are the relaxation time and the exponent of the parameter n in the H-H model.

The power density spectrum of the *Nitella* internodal cell has a bulge in the frequency region around 0.1 Hz. The bulge may be attributed to the conductance fluctuation of the K^+ -channel, as mentioned in the previous section. It is difficult to identify the bulge with a Lorentzian spectrum of the K^+ conductance fluctuation because no blocking agent for the Cl^- - or K^+ -channel of *Nitella* has been found. If the internal K^+ or Cl^- is substituted by impermeant ions, further information about the bulge would be obtained. The conductance fluctuation (Lorentzian spectrum) is, however, probably not separated from the leakage noise ($1/f$ spectrum) by the ion substitution because of the reduction of both noises.

When an oscillatory fluctuation becomes macroscopic at the critical point and subsequently a limit cycle (a time-ordered structure) appears, this instability is called the hard-mode instability or Hopf bifurcation. The theory of oscillatory fluctuation observed near the hard-mode instability point has been developed by Tomita and Tomita (1974). Near equilibrium, detailed balance is regarded as the important characteristic; detailed balance breaks down in the non-equilibrium state. They have proposed a cyclic balance (an irreversible circulation of fluctuation) as a measure of deviation from detailed balance. The circulation of fluctuation is closely connected with the hard-mode instability.

Chen (1975) has considered fluctuations due to kinetic systems at the cycling-steady-state (optical pumping, active membrane transport, muscle contraction, etc.), where detailed balance does not hold. This model gives a spectrum with a maximum value at a frequency other than zero. It has also been shown that a spectral peak can be observed in the system at a non-equilibrium steady state (Chen, 1978). The cycling-steady-state model or Tomita-Tomita's theory would be applied to the metabolic feedback system in the photosynthesis mentioned below.

In *Nitella* internodal cells in APW, a peak in the power spectrum of the potential fluctuation was observed at a potential near threshold when a constant subthreshold current was applied. Critical oscillation of the potential occurred near threshold under a ramp-current stimulation; repetitive firing was induced by applying a step of the superthreshold current. The frequency of the spectral peak, the critical oscillation, and the repetitive firing all agree. This shows that the oscillatory potential fluctuation becomes observable as threshold is approached from the resting state. Subsequently, the limit cycle (the repetitive firing)

appears, although it has short duration due to adaptation. This result suggests that a hard-mode instability exists in *Nitella* internodal cells.

The *Nitella* internodal cell has properties different from squid axon and other membranes: (a) in *Nitella*, the membrane impedance is flat between 0.008 Hz and 1.6 Hz, although the power spectrum peaks at ~ 0.03 Hz, whereas squid axon and other membranes show impedance resonance in the same frequency region as the voltage spectral peaking (Conti et al., 1975; Fishman et al., 1975a; DeFelice et al., 1975; DeHaan and DeFelice, 1978); (b) in *Nitella*, power spectrum peaks at the frequency region are lower than the bulge (Fig. 2), whereas in squid axon and other membranes the peaking occurs at the frequency near or higher than the corner frequency of Lorentzian component; and (c) in *Nitella* the power spectrum has no peak between 0.008 and 100 Hz at the resting state (Fig. 2a), whereas squid axon and other membranes have peaks because of the impedance resonance. These properties are unexplained at present.

If the spectral peaks are ascribed to the conductance fluctuation of channels, channel kinetics may involve cyclic-biochemical reactions. An alternative explanation is that oscillation of the membrane potential is attributable to the electrogenic pump modulated by cyclic metabolism in photosynthesis.

The membrane potential of *Nitella* depends strongly on external pH in light (~ 50 mV/pH) and is more negative than any diffusion potential for major ions, including hydrogen ion, at an external pH 6 to 8. The existence of the electrogenic pump, possibly a H^+ -pump, has been postulated (Kitasato, 1968; Spanswick, 1972; Saito and Senda, 1973a, 1974). The response of the membrane potential to the light can be depressed by addition of the inhibitor [3-(3,4-dichlorophenyl)-1,1-dimethylurea (DCMU), 2,4-dinitrophenyl (DNP), or carbonylcyanide *m*-chlorophenylhydrazone (CCCP)] to the photosynthetic system. Thus it has been suggested that the electrogenic pump is closely linked to photosynthesis (Saito and Senda, 1973b; Spanswick, 1974; Vredenberg and Tonk, 1973).

Hansen (1978) has investigated the frequency response of the membrane potential of *Nitella mucronata* or *Nitella translucens* when the internodal cell is illuminated by a light whose amplitude is modulated sinusoidally. Complex time constants in the transfer function (the ratio of input light and output potential amplitudes) reveal that a feedback loop exists in photosynthetic processes. It has been postulated that the oscillation of the membrane potential ($\sim 2 \times 10^{-4}$ Hz) is due to electrogenic pump modulated by metabolic feedback systems.

The voltage noise spectrum (0.1–300 Hz) of *Chara corallina* has a bump at ~ 40 Hz, although the membrane impedance has no bump (Ferrier and Morvan, 1979). Two possible explanations for the bump have been proposed: (a) fluctuation in the number of open channels and (b) active transport, possibly of HCO_3^- or OH^- , closely linked to photosynthesis. The frequency of the oscillation induced by light (2×10^{-4} Hz: Hansen, 1978) and spectral peaks (40 Hz: Ferrier and Morvan, 1979; 0.03 Hz: present work) all disagree. This disagreement could be due to a variety of species or pumps.

Voltage noise spectra of *Chara brauni* have been measured between 0.1 Hz and 10 kHz by Roa and Pickard (1976, 1977). The magnitude of the noise in the range of 0.1 to 1 Hz is depressed by a metabolic inhibitor [salicylhydroxamic acid (SHAM), DCMU, cyanide, or imidazole] or darkness and deprivation of O_2 and/or CO_2 . These results suggest that the noise resulting from the electrogenic pump linked to metabolism is included in the excess noise

between 0.1 and 1 Hz. It has also been suggested that the magnitude of the excess noise has maximum value near pH 7.35; the electrogenic pump is activated at pH 7–8 (Spanswick, 1972; Saito and Senda, 1973a).

If the spectral peak at 0.03 Hz in the present work is associated with the electrogenic pump driven by photosynthetic processes, the membrane impedance would not always have a peak at the same frequency. The frequency of the spectral peak does also not necessarily correspond to the lifetime of the channel. It may be that the voltage power spectrum peaks well below the bulge attributed to the relaxation process of the channel.

In *Nitella axilliformis*, the resting membrane potential is slightly affected by light, metabolic inhibitor (DCMU, DNP), or temperature (7–20°C) at pH 5.5 (Saito and Senda, 1973a). APW used in the present experiments is pH 5.6. At the resting potential, the electrogenic pump is slightly activated and the spectral peak is not observed. It has been suggested, due to the pH dependence of the I-V relation, that the electrogenic pump is potential-dependent; the pump current decreases with increasing hyperpolarization in *Nitella axilliformis* (Saito and Senda, 1974). It seems likely that when a cell is depolarized by the current the pump is activated to control the internal H⁺ concentration because H⁺ conductance would increase. Actually, when subthreshold constant current is applied, the membrane potential of *Nitella axilliformis* instantaneously shifts to a depolarized level and then the absolute value of the potential increases exponentially with a rate of several tens of minutes. Upon removal of current stimulation, the potential shifts to a hyperpolarized level and returns exponentially to the resting potential (Hayashi and Hirakawa, manuscript in preparation). The gradual change of the membrane potential may be attributed to the electrogenic pump. The spectral peak was observed at a depolarized state even at pH 5.6.

Further observation on effects of external pH, light, or metabolic inhibitors on the spectral peak should provide information about the relationship between the membrane potential oscillation and the electrogenic pump closely linked with the metabolic process.

The authors wish to express their hearty thanks to Professors U. Kishimoto, K. Tomita, H. Kimizuka, Dr. Y. Oono, and Mr. K. Harada for valuable discussion, and to Dr. K. Kuroda who kindly supplied them with *Nitella axilliformis*.

This work was supported in part by the grant 278116 from the Ministry of Education of Japan.

Received for publication 11 June 1979 and in revised form 29 January 1980.

REFERENCES

- ADELMAN, W. J., JR., and R. FITZHUGH. 1975. Solutions of the Hodgkin-Huxley equations modified for potassium accumulation in a periaxonal space. *Fed. Proc.* **34**:1322.
- AIZAWA, Y., and Y. KOBATAKE. 1974. Theory of nerve excitation in reference to energy dissipation. An example of far from equilibrium system. *Prog. Theor. Phys.* **52**:1094.
- CHEN, Y. 1975. Fluctuations and noise in kinetic systems. III. Cycling steady-state models. *J. Theor. Biol.* **55**:229.
- CHEN, Y. 1978. Differentiation between equilibrium and nonequilibrium kinetic systems by noise analysis. *Biophys. J.* **21**:279.
- CHEN, Y., and T. L. HILL. 1973. Fluctuations and noise in kinetic systems. Application to K⁺ channels in the squid axon. *Biophys. J.* **13**:1276.
- CONTI, F., L. J. DEFELICE, and E. WANKE. 1975. Potassium and sodium ion current noise in the membrane of the squid giant axon. *J. Physiol. (Lond.)* **248**:45.

- DEFELICE, L. J., and J. P. L. M. MICHALIDES. 1972. Electrical noise from synthetic membranes. *J. Membr. Biol.* **9**:261.
- DEFELICE, L. J., E. WANKE, and F. CONTI. 1975. Potassium and sodium current noise from squid axon membranes. *Fed. Proc.* **34**:1338.
- DEHAAN, R. L., and L. J. DEFELICE. 1978. Oscillatory properties and excitability of the heart cell membrane. *Theoretical Chemistry*. Vol 4. Academic Press, Inc. New York. 181-233.
- FERRIER, J. M., and C. MORVAN. 1979. Plasmalemma voltage noise in *Chara corallina*. *Plant Physiol. (Bethesda)*. **63**:709.
- FISHMAN, H. M. 1973. Relaxation spectra of potassium channel noise from squid axon membranes. *Proc. Natl. Acad. Sci. U.S.A.* **70**:876.
- FISHMAN, H. M., D. J. M. POUSSART, and L. E. MOORE. 1975a. Noise measurements in squid axon membrane. *J. Membr. Biol.* **24**:281.
- FISHMAN, H. M., L. E. MOORE, and D. J. M. POUSSART. 1975b. Potassium-ion conduction noise in squid axon membrane. *J. Membr. Biol.* **24**:305.
- GAFFEY, C. T., and L. J. MULLINS. 1958. Ion fluxes during the action potential in *Chara*. *J. Physiol. (Lond.)*. **144**:505.
- GUTTMAN, R., and R. BARNHILL. 1970. Oscillation and repetitive firing in squid axons. *J. Gen. Physiol.* **55**:104.
- HAGIWARA, S., and Y. OOMURA. 1958. The critical depolarization for the spike in the squid giant axon. *Jpn. J. Physiol.* **8**:234.
- HANSEN, U. P. 1978. Do light-induced changes in the membrane potential of *Nitella* reflect the feed-back regulation of a cytoplasmic parameter? *J. Membr. Biol.* **41**:197.
- HAYASHI, H., and K. HIRAKAWA. 1979. The instability in the membrane potential of the *Nitella* internodal cell. *J. Phys. Soc. Japan.* **47**:345.
- HILL, T. L., and Y. CHEN. 1972. On the theory of ion transport across the nerve membrane. IV. Noise from the open-close kinetics of K⁺ channels. *Biophys. J.* **12**:948.
- HODGKIN, A. L., and A. F. HUXLEY. 1952. A quantitative description of membrane current and its application to conduction and excitation in nerve. *J. Physiol. (Lond.)*. **117**:500.
- HOPE, A. B., and G. P. FINDLAY. 1964. The action potential in *Chara*. *Plant Cell Physiol.* **5**:377.
- INOUE, I., Y. KOBATAKE, and I. TASAKI. 1973. Excitability, instability and phase transitions in squid axon membrane under internal perfusion with dilute salt solutions. *Biochem. Biophys. Acta.* **307**:471.
- KISHIMOTO, U. 1964. Current voltage relations in *Nitella*. *Jpn. J. Physiol.* **14**:515.
- KITASATO, H. 1968. The influence of H⁺ on the membrane potential and ion fluxes of *Nitella*. *J. Gen. Physiol.* **52**:60.
- KOBATAKE, Y., I. INOUE, and T. UEDA. 1975. Physical chemistry of excitable membranes. *Adv. Biophys.* **7**:43.
- MAILMAN, D. S., and L. J. MULLINS. 1966. The electrical measurement of chloride fluxes in *Nitella*. *Aust. J. Biol. Sci.* **19**:385.
- MATSUMOTO, G., and T. KUNISAWA. 1978. Critical slowing-down near the transition region from the resting to time-ordered states in squid giant axons. *J. Phys. Soc. Japan.* **44**:1047.
- MATSUMOTO, G., I. TASAKI, and I. INOUE. 1978. Oscillatory subthreshold responses and potential fluctuation observed in squid giant axons. *J. Phys. Soc. Japan.* **44**:351.
- MULLINS, L. J. 1962. Efflux of chloride ions during the action potential of *Nitella*. *Nature (Lond.)*. **196**:986.
- NICHOLIS, G., and I. PRIGOGINE. 1977. Self-organization in Non-Equilibrium System. John Wiley & Sons, Inc., New York. 63-220.
- ODA, K. 1975. Recording of the potassium efflux during a single action potential in *Chara corallina*. *Plant Cell Physiol.* **16**:525.
- ODA, K. 1976. Simultaneous recording of potassium and chloride effluxes during an action potential in *Chara corallina*. *Plant Cell Physiol.* **17**:1085.
- POUSSART, D. J. M. 1971. Membrane current noise in lobster axon under voltage clamp. *Biophys. J.* **11**:211.
- ROA, R. L., and W. F. PICKARD. 1976. The use of membrane electrical noise in the study of *Characean* electrophysiology. *J. Exp. Bot.* **27**:460.
- ROA, R. L., and W. F. PICKARD. 1977. Further experiments on the low frequency excess noise of the vacuolar resting potential of *Chara braunii*. *J. Exp. Bot.* **28**:1.
- SAITO, K., and M. SENDA. 1973a. The light-dependent effect of external pH on the membrane potential of *Nitella*. *Plant Cell Physiol.* **14**:147.
- SAITO, K., and M. SENDA. 1973b. The effect of external pH on the membrane potential of *Nitella* and its linkage to metabolism. *Plant Cell Physiol.* **14**:1045.

- SAITO, K., and M. SENDA. 1974. The electrogenic ion pump revealed by the external pH effect on the membrane potential of *Nitella*. Influences of external ions and electric current on the pH effect. *Plant Cell Physiol.* **15**:1007.
- SPANSWICK, R. M. 1972. Evidence for an electrogenic ion pump in *Nitella translucens*. I. The effects of pH, K⁺, Na⁺, light and temperature on the membrane potential and resistance. *Biochim. Biophys. Acta.* **288**:73.
- SPANSWICK, R. M. 1974. Evidence for an electrogenic ion pump in *Nitella translucens*. II. Control of the light-stimulated component of the membrane potential. *Biochim. Biophys. Acta.* **332**:387.
- STEIN, R. B. 1967. The frequency of nerve action potentials generated by applied currents. *Proc. Roy. Soc. London Ser. B. (Biol. Sci.)*. **167**:64.
- STEVENS, C. F. 1972. Inferences about membrane properties from electrical noise measurements. *Biophys. J.* **12**:1028.
- TOMITA, K., and H. TOMITA. 1974. Irreversible circulation of fluctuation. *Prog. Theor. Phys.* **51**:1731.
- VREDENBERG, W. J., and W. J. M. TONK. 1973. Photosynthetic energy control of an electrogenic ion pump at the plasmalemma of *Nitella translucens*. *Biochim. Biophys. Acta.* **298**:354.