

TRANSMISSION ELECTRON MICROSCOPY OBSERVATIONS OF SONICATION-INDUCED CHANGES IN LIPOSOME STRUCTURE

Joseph A.N. Zasadzinski
AT&T Bell Laboratories, Murray Hill, New Jersey 07974

ABSTRACT Freeze-fracture Transmission Electron Microscopy (TEM) was used to show that sonication does not homogeneously disrupt liposome dispersions to form vesicles. Many large multilamellar particles remain intact after sonication and small, unilamellar vesicles are present after just 10 s of exposure. Small vesicles appear to coexist with large liposomes even before sonication. The mechanical and thermal stresses induced by sonication nucleate liquid crystalline defects in the liposomes, including edge and screw dislocations and +1 disclinations, but the Dupin cyclide structure of unsonicated liposomes is still recognizable in the larger particles after sonication. Defects in the bilayer organization may provide pathways for enhanced transport within the liposome, as well as from the liposome interior to exterior. A screw dislocation-catalyzed mechanism of liposome-to-vesicle conversion is proposed that accounts for the TEM observations.

INTRODUCTION

Vesicles are spheroidal structures consisting of an aqueous core surrounded by one or more surfactant bilayers or lamellae (Fig. 1), commonly prepared by prolonged ultrasonication of lamellar liposome dispersions (Huang, 1969). A wide variety of natural and synthetic zwitterionic, cationic, and anionic double-tailed surfactants, as well as a number of single-tailed surfactant mixtures (Hargreaves and Deamer, 1978) form vesicles. Sonicated vesicles have diameters of <50 nm, depending on such experimental variables as the type and concentration of the surfactant, age of the vesicles, and the concentration of added electrolyte (Kaler et al., 1982). Vesicles, and the larger, more heterogeneous liposomes formed by gentle agitation of an aqueous phase in contact with surfactant, are under increasing scrutiny as simple membrane models (Fendler, 1980), delivery vehicles for site-specific or slow-release drugs (Ringsdorf, 1981), microencapsulated catalyst supports for artificial photosynthesis (Fendler, 1984), and surfactant transporters for enhanced oil recovery (Puig, 1982). For many of these applications, small unilamellar vesicles are superior to larger, multilamellar liposomes. However, vesicles eventually revert to multilamellar liposomes (Franses et al., 1982; Kaler et al., 1982). During this process of reversion, the contents of the vesicles may leak out prematurely and cause the delivery system to fail. The greater size and stability of liposomes may be preferable for certain applications; however, it is important to recognize the possible effects of liposome bilayer defects (Zasadzinski et al., 1985) on transport of materials between the liposome interior and exterior and the deformation of

liposome particles in flow. In this study, freeze-fracture electron microscopy was used to examine the structural changes in sodium 4-(1'-heptylnonyl)benzenesulfonate (SHBS) liposomes brought about by the mechanical and thermal effects of ultrasonication. SHBS is a double-tailed, synthetic, ionic surfactant that forms a two-phase dispersion of lamellar liposomes in excess water at high water fractions, similar to double-tailed phospholipids, yet is chemically stable for long periods in water solution and resistant to biological degradation (Franses, 1979). Transmission electron microscopy (TEM) has been used extensively to probe lamellar liquid crystal morphology (Kléman et al., 1977; Zasadzinski et al., 1985) and provides valuable insight into bilayer organization and defects. However, no systematic study has been done to visualize the intermediate structures or the changes in the original structures caused by mechanical disruption of a liposome dispersion. A possible defect-mediated mechanism for nucleating vesicles is outlined and discussed to explain the micrographs.

EXPERIMENTAL PROCEDURES

SHBS was obtained from the University of Texas and purified according to Franses' (1979) protocol. The SHBS liposome samples were prepared at room temperature, which is well above the gel-liquid crystalline transition temperature of -70°C (Blum and Miller, 1982). The doubly-distilled water used to make the dispersions was drawn through a four-stage Millipore cartridge filter system to minimize particulate and organic contaminants. Liposomes were formed by adding measured amounts of water to solid SHBS. The SHBS-water dispersions were homogenized by gentle shaking. The bilayers in liposomes prepared in this way are organized as a single family of Dupin cyclides, with a single ellipse and hyperbola as the curvature singularities (Zasadzinski, 1983).

A 2 wt% dispersion of SHBS liposomes in water was disrupted by

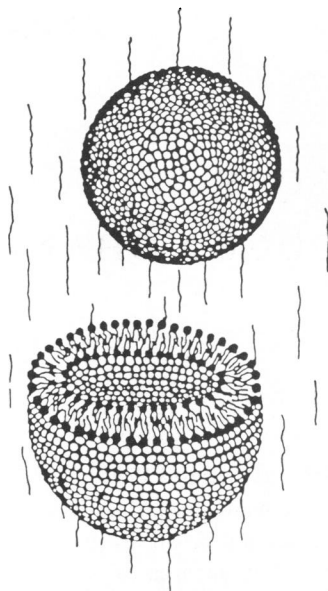

FIGURE 1 Schematic view of unilamellar vesicle in solution. Vesicles consist of one or more bilayers surrounding an aqueous core.

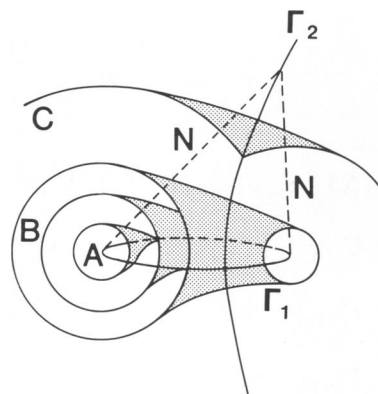

FIGURE 2 Family of Dupin cyclides. The family consists of closed surfaces generated by a conjugate ellipse, Γ_1 , and hyperbola, Γ_2 . Any straight line (dashed lines, N) drawn from any point on the hyperbola is normal to every surface it intersects. The interior cyclide surface A ends in two cusps on the ellipse; the cyclide B resembles a deformed torus and has no cusps; the cyclide C is spheroidal and ends in two cusps on the hyperbola.

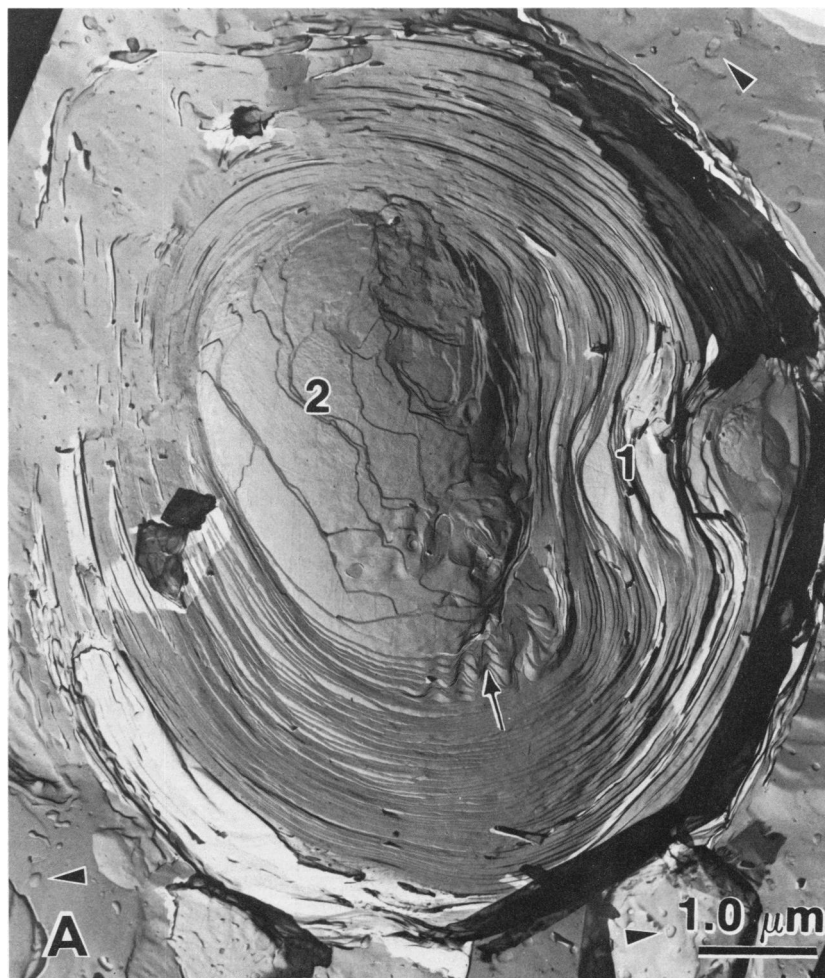

FIGURE 3 Freeze-fracture TEM image of a fractured SHBS liposome and computer generated matching section from a family of Dupin cyclides. 1 and 2 mark points of alignment between image and simulation. A small undulation is present at the long arrow. Short arrows mark small vesicles.

DUPIN CYCLIDE OF ECCENTRICITY 0.60
SECTION THROUGH PLANE:
 $Z = 0.5X - 0.15Y + 0.6$

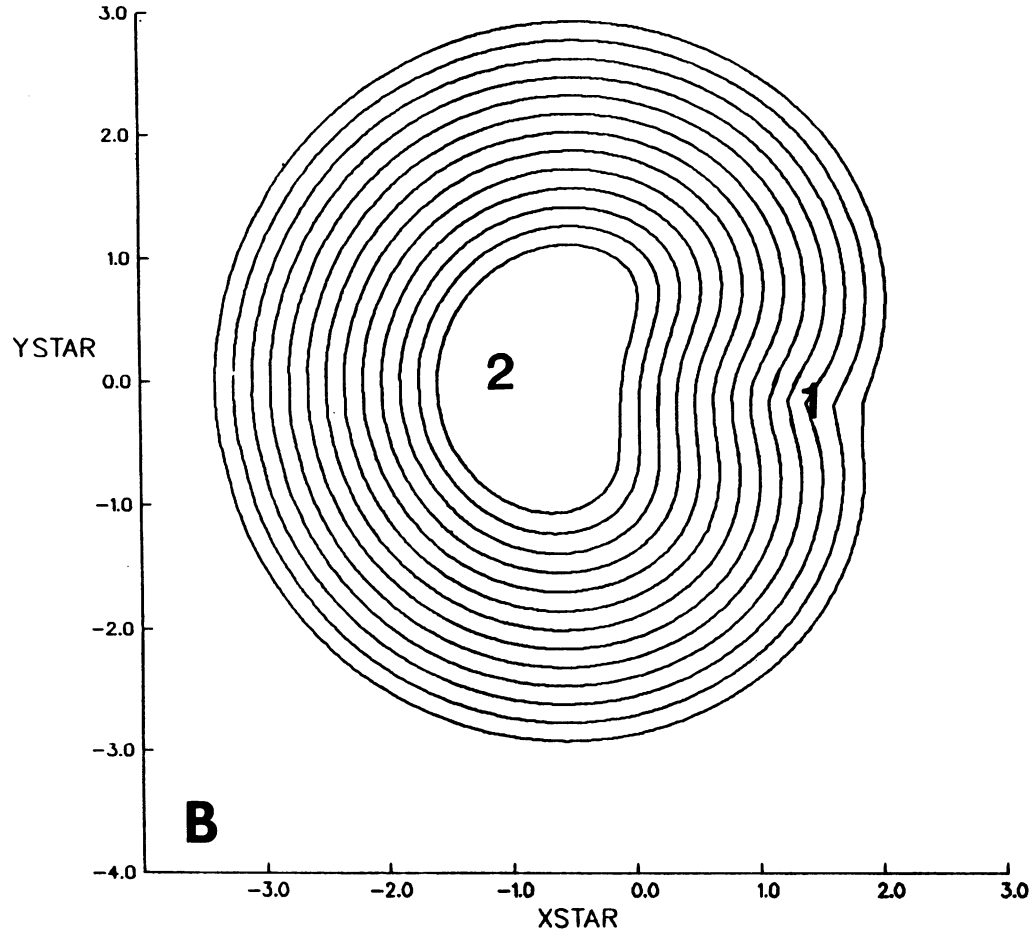

FIGURE 3 Continued

immersing the glass sample vial into the tank of an ultrasonic bath (model 8845-3; Cole-Parmer Instrument Co., Chicago, IL) for times ranging from 10–30 s at room temperature. Samples for TEM were prepared immediately after sonication by trapping a 10–50 μm thick layer of sample liquid between two thin (0.1 mm) copper freeze-fracture plates (Balzers Union, Hudson, NH). The samples were quick-frozen by plunging them into liquid freon cooled by liquid nitrogen. This freezing technique has been used successfully to preserve liposome structure (Zasadzinski, 1983) as well as single-phase lamellar liquid crystal samples (Gulik-Kryzwicki and Costello, 1978). The time elapsed from the end of sonication to quick-freezing was <60 s. The frozen samples were stored under liquid nitrogen until transfer into a freeze-etch unit (model 301; Balzers). The samples were fractured under vacuum ($<10^{-6}$ torr) at -105°C and immediately shadowed with a 2–3 nm thick layer of platinum/carbon at a 45° angle with respect to the fracture surface, followed by a 30 nm thick layer of carbon deposited normal to the surface to increase mechanical strength. The replicas were removed from the Balzers unit, allowed to come to room temperature, and floated off on distilled water. The replicas were collected on uncoated, 400 mesh high transmission electron microscope grids (Polysciences, Warrington, PA) and viewed in a JEOL 100CX scanning transmission electron microscope (model 100CX; JEOL, Peabody, MA) at 100 KeV in the conventional transmission mode.

EXPERIMENTAL OBSERVATIONS

The bilayers in an unsonicated liposome take the form of a family of Dupin cyclides (Fig. 2). Dupin cyclides are preferred configurations for bilayer organization in liposomes because they minimize the curvature and elastic energy of the liquid crystalline bilayers and eliminate hydrophobic-hydrophilic interactions between the surfactant tails and the aqueous phase. The bilayers appear concentric, uniform, and continuous throughout the liposome, and the bilayer surfaces are smooth (Fig. 3). There is evidence of liquid crystalline defects in a small fraction of the unsonicated liposomes, including bilayer undulations, disclinations of strength $+\frac{1}{2}$ and $-\frac{1}{2}$, and edge dislocations. There is no evidence of screw dislocations (Zasadzinski et al., 1985). Smaller, spheroidal particles of ~ 50 nm diameter, such as the ones surrounding the large liposome in Fig. 3, may be uni- or multilamellar vesicles coexisting with the liposomes.

Sonication for 10 s converts many of the liposomes into

irregular, roughly spheroidal particles from 50 nm to almost a micron in diameter (Fig. 4 *a*). Their small size and spheroidal shape suggest that the smaller of these particles are uni-lamellar vesicles; however, it is difficult to determine the interior structure of these particles as they only rarely fracture through their centers. The fracture surface usually propagates around such small particles, either passing over them or plucking them out of the ice surface.

Large, multilamellar liposomes are also present (Fig. 4 *b*). in the same sample. These undamaged liposomes may not have been subject to the local sonication-induced mechanical stresses. Alternatively, undamaged liposomes may contain fewer structural defects prior to sonication, making them more resistant to disruption than other, more defect-ridden liposomes.

Another large, fractured liposome is shown in Fig. 5. The bilayers in this liposome appear distorted, the layers undulate (small arrow) and two edge dislocations of large Burgers vector are present (large arrows). As in the unsonicated liposomes, the edge dislocations are dissociated into $+1/2$ and $-1/2$ disclinations (Kléman et al., 1977; Zasadzinski et al., 1985). The energy (per unit length) of an isolated edge dislocation is

$$E_{\text{edge}} = K \frac{|\mathbf{b}|}{\lambda} + \pi \frac{K}{2} \left[\ln \frac{b}{2d} \right] + \tau_c \quad (1a)$$

K is the Frank splay constant, d is the thickness of a bilayer, b is the Burgers vector of the dislocation, and λ is a characteristic length, of the order of a bilayer thickness, that represents a balance between splay and elastic deformation energy (deGennes, 1974):

$$\lambda = (K/B)^{1/2}. \quad (1b)$$

K , the splay constant, ranges from 2×10^{-6} for saturated phospholipids (Schneider et al., 1984) to 6×10^{-8} for synthetic ethoxolated alcohols (Oswald and Allain, 1985). B , the elastic constant, is $\sim 10^7$ dyn/cm² (Kléman et al. 1977, Oswald and Allain 1985). τ_c is the energy of the edge dislocation in the region immediately surrounding the core of the defect in which the continuum elasticity equations are no longer valid. τ_c has little dependence on \mathbf{b} (Kléman, 1983). The form of the energy of the edge dislocation (1) promotes a small number of edge dislocations of large Burgers vector (Kléman, 1983). This seems to hold true for both unsonicated and sonicated liposomes. It is difficult to say, however, if the dislocations present in the sonicated particles were originally nucleated as large Burgers vector defects or are the result of many smaller edge dislocations coalescing into one.

The distorted liposome in Fig. 5 is surrounded by smaller, 50–500 nm. diameter, spheroidal particles that most likely are vesicles. Several, small spheroidal inclusions on the liposome surface (A) may be vesicles in contact with the liposome surface.

Undulations in the liposome bilayers can take on large magnitudes as shown in Fig. 6 *a* and 6 *b*, but most of the distortion is limited to regions of small lateral extent. The threshold strain for undulations (Clark and Meyer, 1973) is

$$\gamma_{\text{th}} = 2\pi\lambda(1 + 2\pi\lambda/D). \quad (2)$$

γ_{th} is the threshold strain on a planar sample of thickness D . For large D , γ_{th} is $\sim 6\lambda$, or six times the bilayer thickness. The bilayers undulate to relax the strain energy at the lower expense of curvature energy. The amplitude of the undulations is (Clark and Meyer, 1973):

$$A = \lambda[(\gamma - \gamma_{\text{th}})/\gamma_{\text{th}}]^{1/2}, \quad (3)$$

in which γ_{th} is the imposed strain on a system of bilayers with a threshold strain of γ_{th} . The stresses on the liposome bilayers caused by sonication clearly induce strains much larger than γ_{th} and lead to the large local distortions seen in Fig. 6. Such large undulations may shear the bilayers and result in the formation of edge and screw dislocations. The undulations, once formed, are slow to relax; it is possible to “capture” and visualize them even after as much as a sixty-second delay between sonication and freezing.

Fig. 7 *a* shows a fracture of an SHBS liposome near the liposome-water interface. It is crossed by fine cleavage steps, or “rivers” of one of two bilayers in thickness. The steps connect small patches, one or two bilayers thick. These cleavage patterns are similar to those observed in lecithin bilayers by Kléman et al. (1977) and Allain (1985), who claimed that they are evidence of screw dislocations piercing the bilayer surfaces. As drawn in Fig. 8 *a*, a screw dislocation in a lamellar phase resembles a spiral staircase with the screw axis perpendicular to the bilayers. The Burgers vector of a screw dislocation is required by continuity to equal a multiple of the bilayer thickness (Pershan, 1974). The cleavage patterns on the SHBS liposome surfaces are not as well defined as those observed by Kléman et al., but this may be because of the 3.3-nm bilayer thickness in SHBS (Blum and Miller, 1982), compared to the 6–7 nm for lecithin bilayers. The density of screw dislocations in room temperature single-phase smectic samples is large, namely 10^8 cm⁻² (Kléman, 1983) and increases with temperature with an Arrhenius type dependence (Allain, 1985). In unsonicated liposome dispersions, however, screw dislocations appear to be absent (Zasadzinski et al., 1985). The absence of screw dislocations in liposome dispersions is presumably caused by the large energy caused by contacting a bilayer’s hydrocarbon interior, which is exposed when a screw dislocation pierces the liposome surface, to the aqueous phase. Screw dislocations are line defects and are topologically required to end at a free surface or another dislocation. The screw dislocation line is perpendicular to the bilayers; therefore, a pure screw dislocation loop cannot form within a liposome because the normals to the bilayers

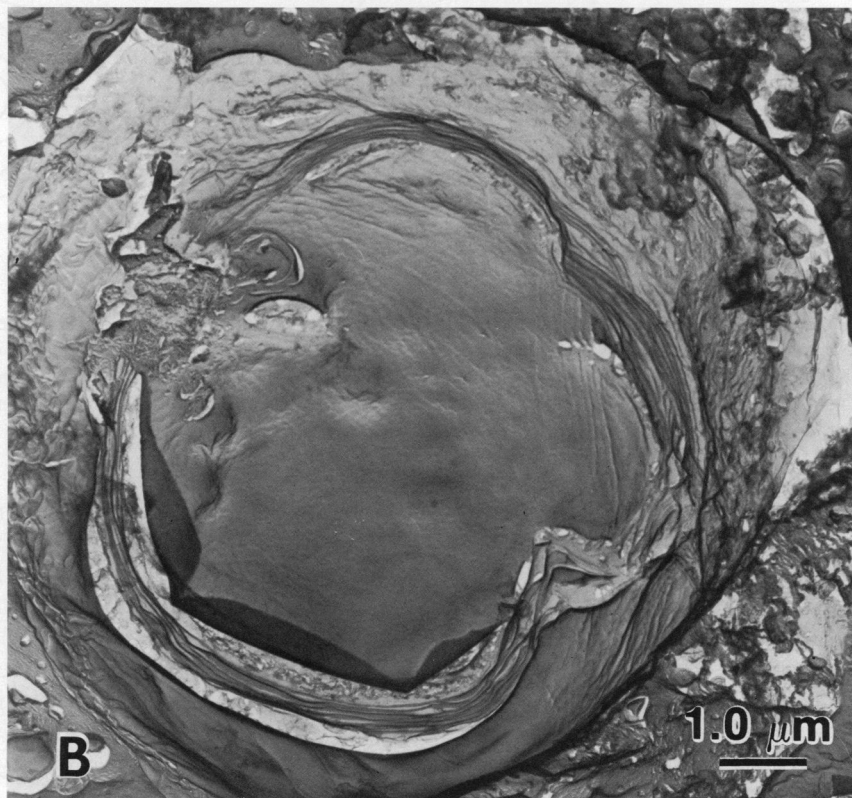
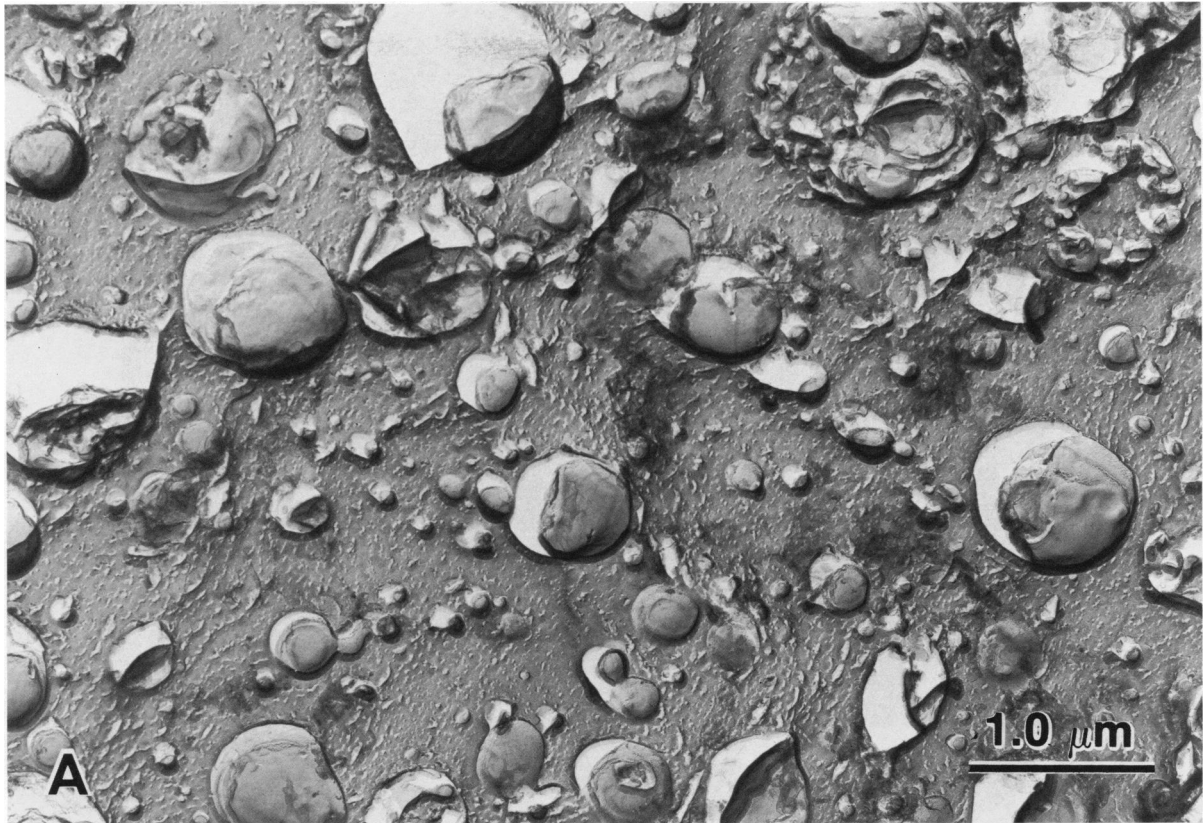

FIGURE 4 (a) Spheroidal particles of SHBS from dispersion sonicated 10 s. Smaller particles are most likely unilamellar vesicles. (b) Large, multilamellar liposome from the same sample *a*, showing no signs of deformation.

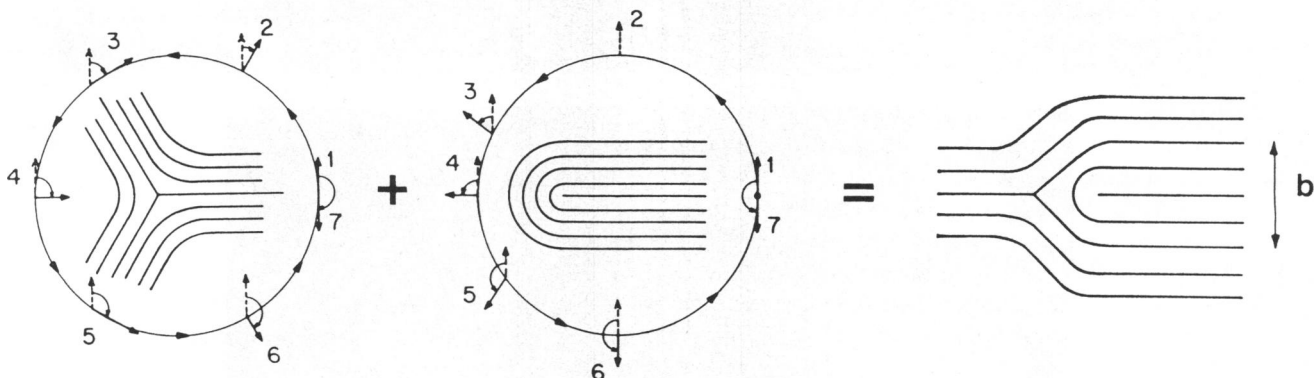
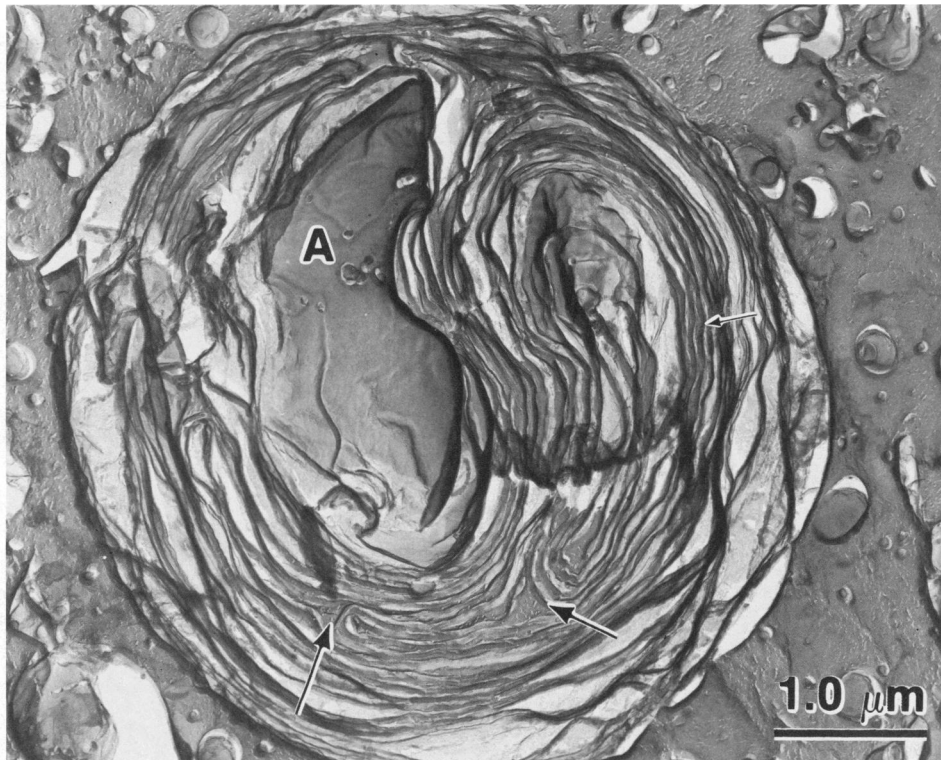

FIGURE 5 Sonicated liposome from a 2 wt% dispersion of SHBS in water. Many of the bilayers in the liposome appear distorted. Note the undulations at the small arrow, and large Burgers vector edge dislocations at the large arrows. The edge dislocations are dissociated into paired $+\frac{1}{2}$ and $-\frac{1}{2}$ disclinations as shown in the drawing below. Both disclination lines and the edge dislocation lines are perpendicular to the plane of the page. Rotation of the normal (arrows 1–7) in the same direction as the loop signifies a positive disclination; in the opposite sense, a negative disclination. b is the Burgers vector of the edge dislocation, and is perpendicular to the dislocation line.

are straight and cannot close on themselves, except at the elliptical curvature singularity of the Dupin cyclide (See Fig. 2). This is a geometric property of the Dupin cyclide structure (Maxwell, 1868). An edge dislocation line, on the other hand, is parallel to the bilayers and must necessarily form loops. Any configuration of the bilayers of a lamellar phase that minimizes the curvature and elastic energy consists of surfaces whose normals are straight lines (Frank, 1958). Therefore, most screw dislocations in a lamellar liposome end at the liposome-water interface; the bilayer edge exposed at the interface is of high energy because the hydrocarbon tails are in contact with water

along this edge. This creates a driving force to anneal any screw dislocations present and inhibit the nucleation of new screw dislocations. A screw dislocation, however, has zero elastic energy (Pershan, 1974); there is no long-range stress field because the screw dislocation preserves the local bilayer thickness except at the dislocation core. The core energy (per unit length) of an isolated screw dislocation is estimated by Kléman (1983) to be

$$E_{\text{screw}} = Bb^4/128\pi^3r_c^2 \quad (4)$$

r_c is the radius of the core of the dislocation, b is the Burgers vector of the defect and B is the elastic constant of

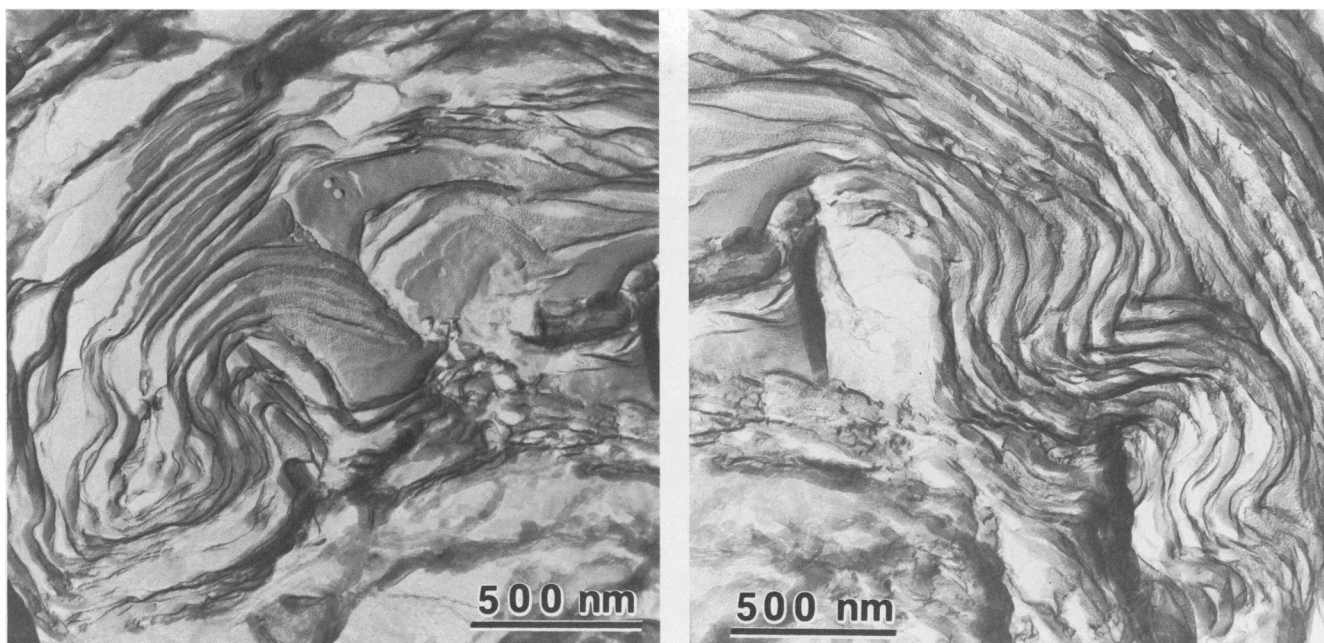

FIGURE 6 Large amplitude undulations in the bilayers of sonicated SHBS liposomes.

the lamellar phase. Because the energy depends on the fourth power of the Burgers vector, only screw dislocations of small Burgers vector are likely to form. This prediction has been verified experimentally by Allain (1985), who only observed screw dislocations with Burgers vectors of a single bilayer. Still, the total energy of a screw dislocation is only a small fraction of that of an edge dislocation (the core energy (4) should be comparable to τ_c in (1)), hence the disrupting stresses of sonication are most likely to introduce screw dislocations of small Burgers vector than edge dislocations of similar Burgers vector into the liposome. However, this energy (4) does not include the energy of contacting the free edge of the bilayer exposed at the liposome-water interface to the excess water phase. It is possible to create a rectangular, mixed screw-edge dislocation loop by connecting two screws of opposite sign with edge dislocation lines of equal Burgers vector (See Fig. 8 *b*). Such loops could be contained entirely within the liposome, with no resulting exposed edge at the liposome surface. These screw-edge loops are responsible for the small bilayer steps present in Fig. 7 *b*.

A few large multilamellar liposomes are still present even after 30 s of sonication (Fig. 9 *a*). Although the overall morphology of the liposome bilayers can be modelled by a section through a family of Dupin cyclides (Fig. 9 *b*), the fine structure of the liposome is distorted. Undulations (small arrows), edge dislocations (medium arrows) and a cylindrically shaped +1 disclination (large arrow) (Frank, 1958) are present in the liposome. The bilayers have lost the smooth, continuous appearance they had prior to sonication. Still, the liposome interior is more or less well ordered, and the disorder is localized in the liquid-

crystalline defects. No unstructured chunks of bilayers were observed in any of the micrographs, only well-ordered liposomes. Some large, multilamellar liposomes survive hours of sonication (Kaler et al., 1982).

DISCUSSION OF RESULTS

Multilamellar liposomes of SHBS are particles, 1–100 μm in diameter, whose bilayer organization is well modelled by a family of Dupin cyclides. Dupin cyclides are closed, parallel surfaces that are preferred configurations for lamellar liquid crystalline bilayer organization in liposomes. The bilayer organization in unsonicated liposomes is distorted by a small density of local liquid crystalline defects, usually bilayer undulations and edge dislocations. No screw dislocations are observed before sonication. On sonication, the multilamellar liposomes are eventually transformed into small, unilamellar vesicles <50 nm in diameter. The vesicles are unstable with respect to the multilamellar liposomes and eventually revert to the latter.

In our experience, the rate of disruption of a liposome dispersion by sonication is independent of the type of surfactant or the electrolyte concentration, as long as the dispersion is sonicated above the gel-liquid crystalline transition temperature of the particular surfactant in the dispersion. Because the equilibrium monomer concentration can vary among double-tailed surfactants that form vesicles by several orders of magnitude (10^{-8} wt% for long-tailed lecithins to 0.1 wt% for SHBS at room temperature), vesicle nucleation cannot involve the dissolution of monomer surfactant from liposomes and a subsequent reorganization into vesicles.

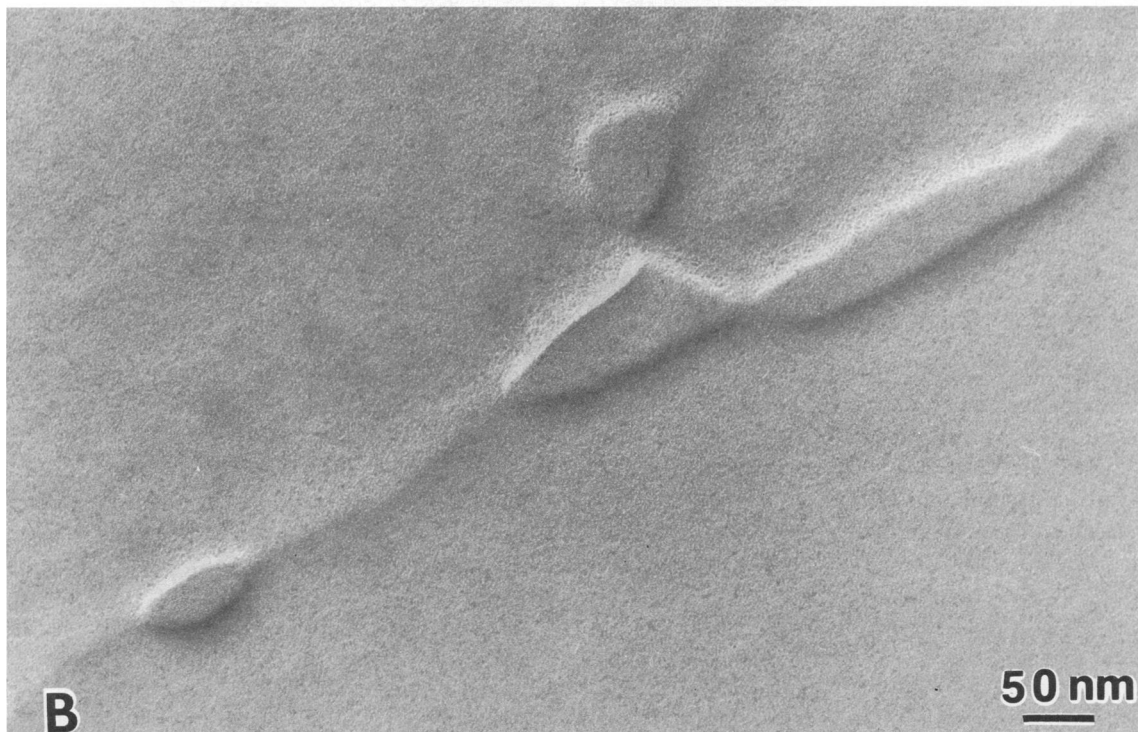
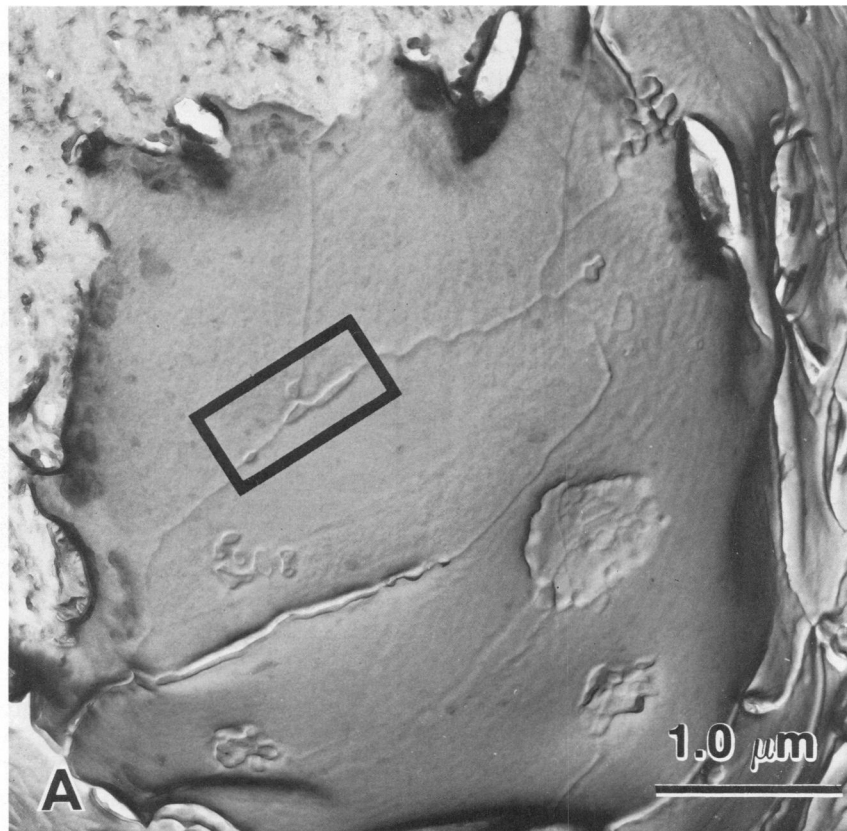

FIGURE 7 (a) Freeze-fracture image of the surface of a SHBS liposome. The surface is crossed by small cleavage steps that are evidence of screw dislocations in the bilayers. Enlarged view of boxed area is shown in *b*. (b) Enlarged view of small bilayer patches on liposome surface. These patches are edge-screw dislocation loops as drawn in Fig. 8 *b*.

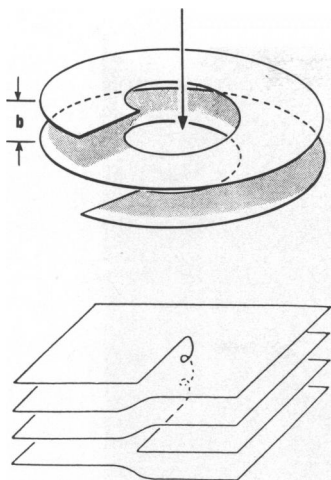

FIGURE 8 (a) Configuration of a screw dislocation in a lamellar phase. The bilayer spacing is maintained except at the core, or axis, of the screw defect. b is the magnitude of the Burgers vector that is parallel to the axis (arrow) of the defect. (b) Configuration of a screw-edge dislocation loop, cut at the mirror plane (After Allain, 1985).

Even before sonication, a small population of vesicle-sized particles (<50 nm diameter) appears to coexist with large liposomes. After 10 s of sonication, a much larger number of small spheroidal particles with diameters ranging from 30 to 500 nm are observed. It is difficult to say whether the larger of these particles have aqueous vesicle-like cores, or are simply small liposomes. However, it is likely that the smallest particles—those with a diameter <100 nm—are unilamellar or a few-layered vesicles. Many large liposome particles survive short periods of sonication intact and some survive even hours of sonication. Freeze-fracture images of the surviving liposomes suggests that these particles retain a good deal of bilayer organization, but the density of edge and screw dislocations is increased by sonication-induced stresses. Large amplitude bilayer undulations are also induced by sonication and may be nucleation sites for the dislocation defects. However, the large liposomes retain their integrity and do not appear to fragment into smaller multilayered chunks.

The presence of dislocation defects alter the transport properties of the bilayer membranes. Dislocations are pathways for enhanced transport of solute molecules (Asher and Pershan, 1979; Schneider et al., 1983). If a screw dislocation pierces the liposome surface, solute molecules can escape the liposome interior without ever having to diffuse through a bilayer; the molecules simply diffuse along a continuous spiral pathway from liposome interior to exterior (See Fig. 7). A polar solute molecule need not cross the hydrophobic bilayer interior; a non-polar molecule need not traverse the hydrophobic headgroups. The stress required to nucleate dislocation defects determines the possible applications of liposomes as delivery vehicles. It is clear that the thermal and mechanical stresses produced by ultrasonication are more than adequate to

induce defects in the liposome structure. However, the minimum stress required to induce dislocation defects is not known.

Possible Mechanisms of Defect-mediated Vesicle Nucleation

When an ultrasonic wave propagates in a liquid, the liquid is alternately compressed and expanded. At a certain oscillation intensity, the pressure wave amplitude can reach a value at which the liquid integrity is broken locally and a cavity is formed that is closed in the second half cycle. This process is called cavitation. As the cavities close, the fast moving liquid particles collide at the cavity center and produce a spherical impact wave. The pressure amplitude of the impact wave can be orders of magnitude greater than the pressure amplitude of the ultrasonic oscillation that caused the original cavitation. With the contraction of cavities and the propagation of the impact pressure wave, the temperature in the vicinity of the cavity can rise for a brief interval by several tens or hundreds of degrees (Puskar, 1982).

The dual effects of pressure and temperature oscillations caused by ultrasonication enhance the nucleation of liquid crystalline defects in liposomes. The oscillations are localized, however, and this results in certain liposomes being severely disrupted and others not being affected. The pressure oscillations cause large, but localized strains in the liposomes, inducing large amplitude bilayer undulations. These undulations, if large enough, may cause the bilayers to shear, resulting in edge and screw dislocations. Conductivity measurements show that the monomer SHBS concentration increases during sonication (Kaler, E.W., and G. Johnson, personal communication), indicating that the local temperature does rise. The equilibrium monomer concentration of SHBS changes by more than an order of magnitude from 0.06 wt% at 25°C to 0.75 wt% at 95°C. Of greater influence on defect nucleation, the localized heating decreases the elastic constant, B , as the local temperature approaches the liquid crystal-isotropic transition. As B decreases, the energy required to nucleate defects also decreases (see Eqs. 1–4). In addition, the energy of hydrophobic-hydrophilic repulsion decreases, causing a rapid increase in the dislocation density (Allain, 1985).

The absence of long-range elastic energy makes screw dislocations more likely to form than edge dislocations on sonication. The screw dislocations formed are topologically required to end at the liposome-water interface (or at another dislocation), resulting in an exposed bilayer edge. These bilayer edges are of high energy because of the hydrophobic-hydrophilic repulsion between the exposed hydrocarbon tails and the aqueous phase. There are two ways of eliminating this free edge. The first is by annealing the defect, a slow process involving interlayer transport of surfactant molecules (Chan and Webb, 1981). The second method may involve peeling off the exposed bilayer edge

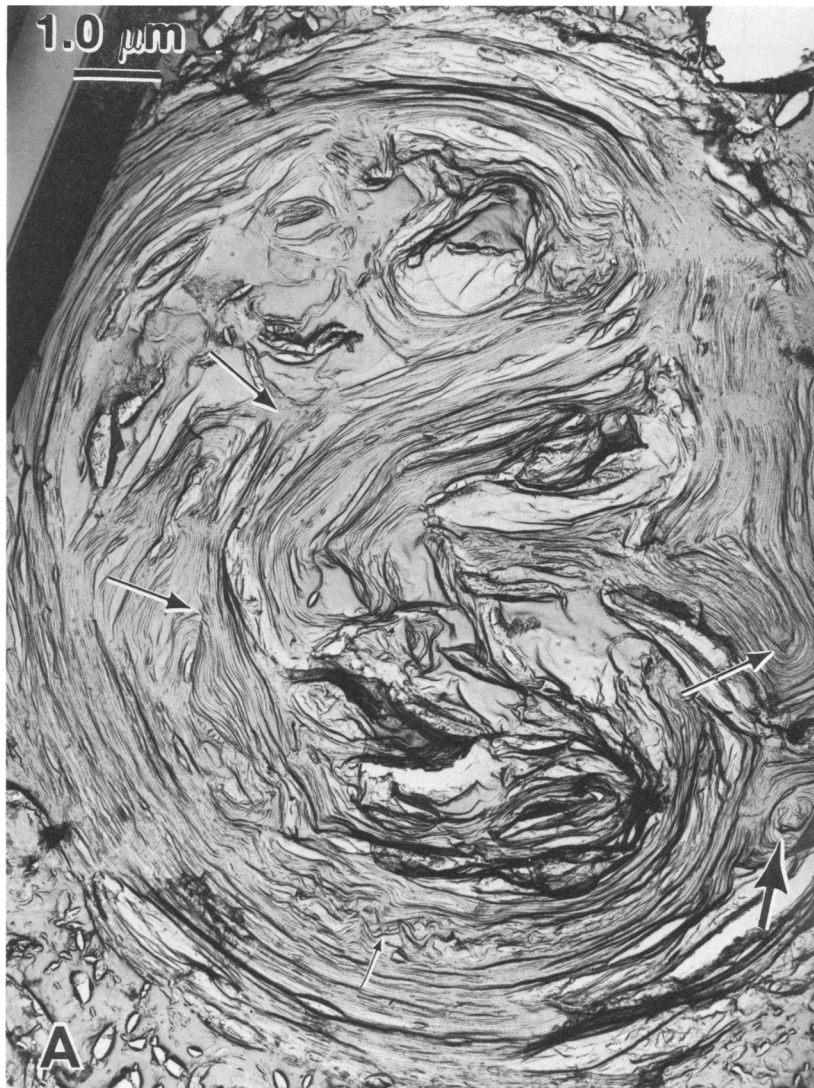

FIGURE 9 (a) Freeze-fracture image of liposome from a SHBS dispersion sonicated for 30 s. (b) The overall patterns of the bilayers can be modeled as a family of Dupin cyclides.

(similar to peeling an onion). The unraveled edge can rearrange to form a closed vesicle at the liposome surface, or alternately, the unraveled edge may be sheared off during subsequent ultrasonic events and reorganize at a later time. Changing the shape of a bilayer sheet is a fast process that only involves displacement of the surfactant molecules within the bilayer. Once the unraveled edge is sheared off, the screw dislocation is again exposed and the vesicle nucleation site is restored. A screw dislocation is, therefore, a catalyst for vesicle nucleation because it is regenerated unchanged.

Whether a bilayer sheet with exposed edges closes to form a vesicle depends on the relative magnitudes of the edge energy and the elastic curvature energy. At a bilayer edge, the hydrocarbon tails of the amphiphile are exposed to water. The free energy change (in calories per mole) upon taking a hydrocarbon molecule from a water environment to a hydrocarbon environment was given by Tanford

(1973)

$$\mu_{hc} - \mu_w = 2,436 - 884n_c \quad (5)$$

n_c is the number of carbon molecules in the hydrocarbon chain. A bilayer has a relatively fixed number of molecules per length of edge. Multiplying the number of molecules per length of edge by the free energy change per molecule gives an estimate of the energy per length of bilayer edge, L . Assuming the molecules are 0.5–1.0 nm apart, L is roughly 10^{-5} dyn. A bilayer of thickness d in the form of a spherical shell of radius R has a curvature energy of $8\pi Kd$ (Fromherz, 1983; Zasadzinski, 1985), but zero edge energy. A flat circular sheet of bilayer equal in area to the sphere has an edge energy of $4\pi RL$, but zero curvature energy. Therefore, a flat sheet is expected to ball up into a sphere whenever

$$4\pi RL > 8\pi Kd \quad \text{or} \quad R > 2dK/L. \quad (6)$$

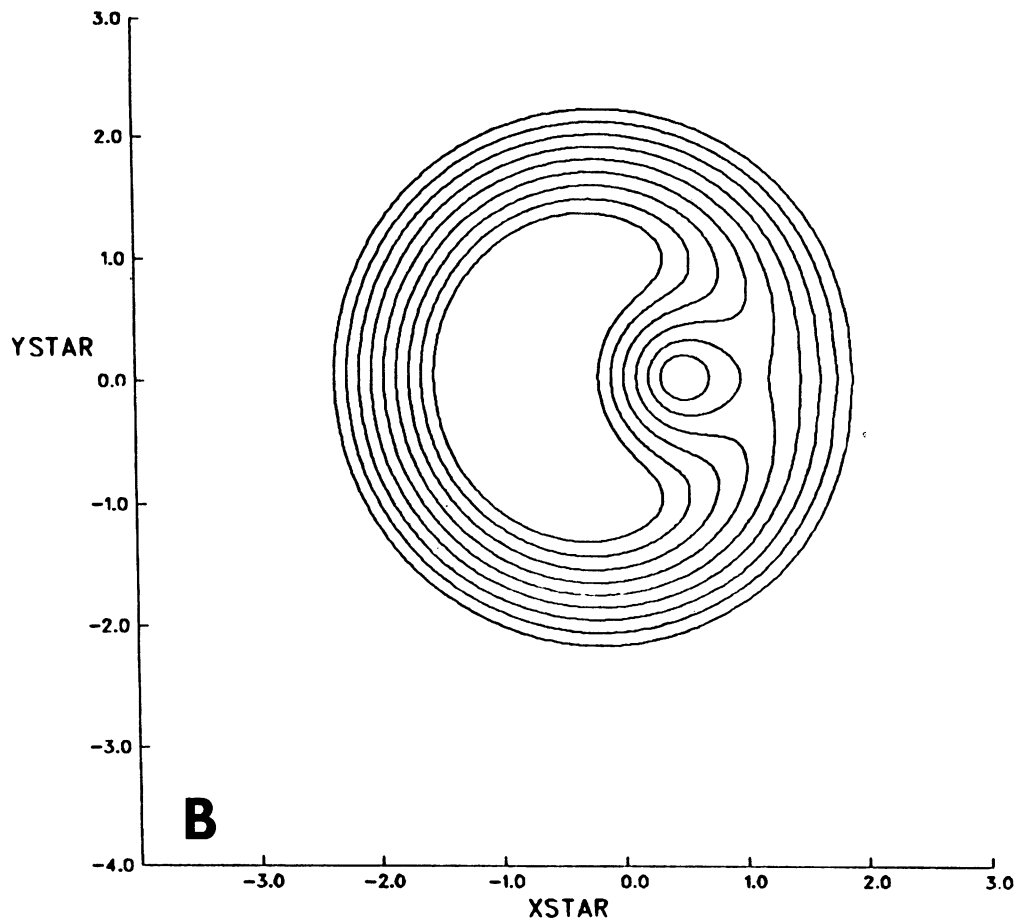

FIGURE 9 Continued

For typical values of K , L , and d (10^{-6} dyn, 10^{-5} dyn, and 6 nm, respectively) the flat sheet will ball up into a sphere whenever $R > 1.2$ nm, a fraction of the bilayer thickness. The energy cost of exposing a hydrophobic edge to the solvent is greater than the curvature energy for any reasonable vesicle radius; hence the closed shell is always preferred to a flat sheet with edges. Experimentally, it is observed that the minimum radius of a bilayer vesicle is 3–5 times the bilayer thickness (Kaler et al., 1982); however, the continuum approximation of constant K in Eq. 6 is not valid for structures in which the radius of curvature approaches molecular dimensions (Frank, 1958). Fromherz and Ruppel (1985) have observed the transition between flat sheets and closed vesicles by adding an “edge-actant” (taurochenodesoxycholate) to a sonicated phospholipid dispersion. The edge-actant reduces the edge energy, L , of the bilayer by shielding the hydrophobic tails from the water. This dramatically slows the transition between flat bilayer sheets (produced by sonication) and closed vesicles and allows the intermediate structures to be visualized with TEM. Shortly after sonication, these

authors observe a heterogeneously sized population of small (10–50 nm diameter) bilayer fragments that slowly transforms into unilamellar vesicles.

Because the energy of a screw dislocation is proportional to the fourth power of the magnitude of the Burgers vector, screw dislocations with a Burgers vector of a single bilayer are most likely to form; hence unilamellar vesicles are also most likely to be formed. The initial sizes and shapes of the vesicles vary (as observed by Fromherz and Ruppel) because the density of screw dislocation defects varies from liposome to liposome. One implication of this defect-catalyzed nucleation mechanism that is observed experimentally is that vesicles form much more slowly below the gel-liquid crystalline transition temperature. This is because defect mobility decreases dramatically (Chan and Webb, 1981) and the bilayers are much less fluid (Chapman and Fluck, 1966) below this temperature.

Disruption of liposomes by this hypothesized mechanism would likely occur stepwise, first by the screw dislocation catalyzed nucleation of heterogeneously sized uni- and multilamellar bilayer fragments that quickly close to form

vesicles. This step should be fast. The second, and much slower step, would be the further disruption of the initial population of heterogeneously-sized vesicles into smaller vesicles, more uniform in size. The minimum size of a vesicle is set by steric or molecular packing constraints that prohibit the bilayer sheets from forming smaller and smaller closed vesicles. Any bilayer fragments smaller than this minimum size likely dissociate into monomers and are responsible for the rise in local concentration as measured by Kaler and Johnson (1985). The resistance to bending the bilayers increases with curvature and originates in the intermolecular forces, the repulsive parts of which control the effective shape of the molecules, and thus their packing. The large, multilamellar liposomes that survive sonication may have fewer defects before sonication, making them more resistant to disruption. More likely, the localized nature of the temperature and pressure oscillations induced by sonication may mean that some liposomes simply are not subjected to any disrupting influences, and thus survive sonication intact.

The experimental observations reported herein were performed at the University of Minnesota, Department of Chemical Engineering and Materials Science. I thank my advisors, Drs. L. E. Scriven and H. T. Davis for suggestions on the manuscript.

I would also like to recognize the financial support of a National Science Foundation Fellowship and a University of Minnesota Doctoral Dissertation Fellowship.

Received for publication 14 June 1985 and in final form 17 December 1985.

REFERENCES

- Allain, M. 1985. Defaults dans des phases lamellaires lyotropes observés par cryofracture et microscopie électronique. *J. Phys. (Paris)*. 46:225–234.
- Asher, S. A., and P. S. Pershan. 1979. Alignment and defect structures in oriented phosphatidylcholine multilayers. *Biophys. J.* 27:399–422.
- Blum, F. D., and W. G. Miller. 1982. Temperature dependence of molecular motion in smectic liquid crystals of hydrated SHBS. *J. Phys. Chem.* 86:1729–1734.
- Chan, W. K., and W. W. Webb. 1981. Observation of elementary edge dislocations in phospholipid multilayers and of their annealing as a determination of the permeation coefficient. *J. Phys. (Paris)*. 42:1007–1013.
- Chapman, D., and D. J. Fluck. 1966. Electron microscope studies of some pure fully saturated 2,3-diacyl-DL phosphatidyl-ethanolamines and cholines. *J. Cell Biol.* 30:1–11.
- Clark, N. A., and R. B. Meyer. 1973. Undulation instability in smectic-A liquid crystals. *Appl. Phys. Lett.* 22:493–501.
- deGennes, P. G. 1974. *The Physics of Liquid Crystals*. Oxford University Press, Oxford. 277–323.
- Fendler, J. H. 1980. Surfactant vesicles as membrane mimetic agents: characterization and utilization. *Accounts Chem. Res.* 13:7–13.
- Fendler, J. H., 1984. Polymerized surfactant vesicles: novel membrane mimetic systems. *Science. (Wash. DC)*. 223:888–894.
- Franses, E. I. 1979. Ph. D. Thesis. University of Minnesota, Minneapolis, MN.
- Franses, E.I., Y. Talmon, L. E. Scriven, H. T. Davis, and W. G. Miller. 1982. Vesicle formation and stability in the surfactant sodium 4-(1'-heptylnonyl)benzenesulfonate. *J. Colloid Interface Sci.* 86:449–467.
- Frank, F. C. 1958. On the theory of liquid crystals. *Disc. Faraday Soc.* 25:19–28.
- Fromherz, P. 1983. Lipid-vesicle structure: size control by edge-active agents. *Chem Phys. Lett.* 94:259–266.
- Fromherz, P., and D. Ruppel. 1985. Lipid-vesicle formation: the transition from open disks to closed shells. *FEBS (Fed. Eur. Biochem. Soc.) Lett.* 179:155–159.
- Gulik-Krzywicki, T., and M. J. Costello. 1978. Use of low-temperature x-ray diffraction to evaluate freezing methods used in freeze-fracture electron microscopy. *J. Microsc. (Oxf.)* 112:103–113.
- Hargreaves, W. R., and D. W. Deamer. 1978. Liposomes from ionic, single-chain amphiphiles. *Biochemistry*. 17:3759–3768.
- Huang, C. 1969. Studies of phosphatidylcholine vesicles: formation and physical characteristics. *Biochemistry*. 8:344–351.
- Kaler, E. W., A. H. Falls, H. T. Davis, L. E. Scriven, and W. G. Miller. 1982. Characterization and aging of aqueous vesicular dispersions of sodium 4-(1'-heptylnonyl) benzenesulfonate. *J. Colloid Interface Sci.* 90:424–443.
- Kléman, M. 1983. *Points, Lines and Walls*. John Wiley & Sons, New York. 121–132.
- Kléman, M., C. E. Williams, M. J. Costello, and T. Gulik-Krzywicki. 1977. Defect structures in lyotropic smectic phases revealed by freeze-fracture electron microscopy. *Phil. Mag.* 35:33–56.
- Maxwell, J. C. 1868. On the cyclide. *QJ. Pure Appl. Math.* 9:111–126.
- Oswald, P., and Allain, M., 1985. Influence of structural defects on the viscoelastic properties of a lamellar lyotropic phase. *J. Phys. (Paris)*. 46:831–838.
- Pershan, P. S. 1974. Dislocation effects in smectic-A liquid crystals. *J. Appl. Phys.* 45:1590–1604.
- Puskar, A. 1982. *The Use of High-Intensity Ultrasonics*. Elsevier Press, New York. 20–56.
- Ringsdorf, H. 1981. Polymerized liposomes and vesicles. *Angew. Chem. Int. Ed. Eng.* 20:305–325.
- Schneider, M. B., W. K. Chan, and W. W. Webb. 1983. Fast diffusion along defects and corrugations in phospholipid P_{β} liquid crystals. *Biophys. J.* 43:157–165.
- Schneider, M. B., J. T. Jenkins, and W. W. Webb. 1984. Thermal fluctuations of large quasi-spherical bimolecular phospholipid vesicles. *J. Phys. (Paris)*. 45:1457–1472.
- Zasadzinski, J. A. 1983. *In Proceedings 41st Annual EMSA Meeting*. G. W. Bailey, editor. San Francisco Press, San Francisco, CA 646–647.
- Zasadzinski, J. A. 1985. Ph. D. Thesis. University of Minnesota, Minneapolis, MN.
- Zasadzinski, J. A., L. E. Scriven, and H. T. Davis. 1985. Liposome structure and defects. *Phil. Mag. A*. 51:287–302.