

TECHNICAL NOTE

A CHAMBER FOR THE INSTRUMENTAL CONTROL OF LICKING BEHAVIOR IN THE LABORATORY MOUSE<sup>1</sup>

Licking rates are commonly used dependent variables in drinking and fluid preference studies. In a typical application, such as Stellar and Hill's (1952) study of drinking rates in water-deprived rats or Fuller's (1967) study of alcohol preference in mice, one or more drinking tubes are made available to the subject. Each drinking tube is connected to a contact relay (drinkometer) and the subject's licking responses are counted or recorded on a cumulative record. Ordinarily no attempt is made to acquire instrumental control of licking behavior. Under these conditions, Corbit and Luschei (1969) have shown that the drinking rate of rats is quite invariant and that ingestion volume is controlled by duration of drinking.

When licking behavior is brought under instrumental control, differential response rates are easily

demonstrated, e.g., Fisher (1965) and Sidman, Ray, Sidman, and Klinger (1966). The use of licking behavior in an operant situation should be useful in many experimental situations and is particularly appropriate in studies concerned with preferences or the control of ingestion.

The present apparatus is designed to allow instrumental conditioning of the licking response of laboratory mice. Six such chambers are currently in use. The chambers are housed in pairs in sound attenuated, ventilated, light controlled boxes. Figure 1 is a sketch of the assembled chamber and indicates points of connection to scheduling, reinforcing, and recording devices.

Figure 2 is a detailed sketch of the apparatus before final assembly. The apparatus is designed to be easily

<sup>1</sup>This research was supported by Public Health Service Research Grant Number MH 11327. Reprints may be obtained from Richard L. Sprott, The Jackson Laboratory, Bar Harbor, Maine 04609.

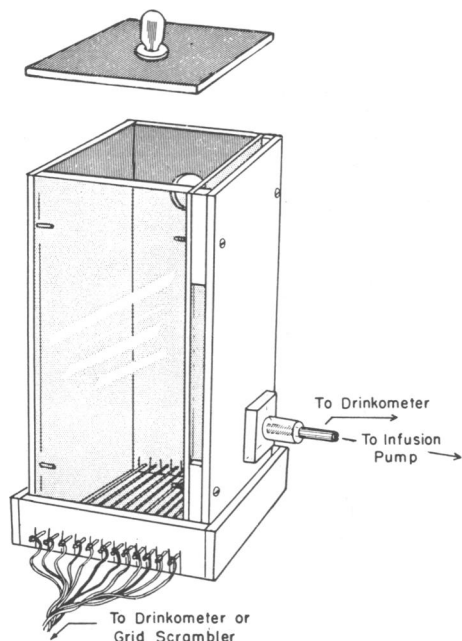

Fig. 1. Diagram of the assembled conditioning chamber.

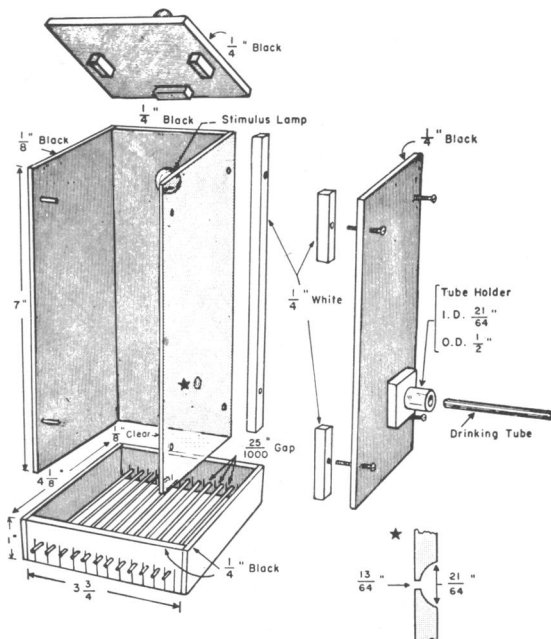

Fig. 2. Exploded view of the conditioning chamber. The front of the chamber, made of 1/4" clear plexiglass is not shown. Standard international system of units equivalents for dimensions shown are as follows: 1 in. = 25.4 mm, 1/4 in. = 6.4 mm, 1/8 in. = 3.2 mm, 7 in. = 17.8 cm, 4 1/2 in. = 10.5 cm, 3 3/4 in. = 9.5 cm, 2 1/64 in. = 8.3 mm, 1 3/64 in. = 5.2 mm, 1/2 in. = 12.7 mm, 25/1000 in. = 0.7 mm.

disassembled to the state shown for easy cleaning or replacement of parts. Plexiglas walls are used because mice cannot cling to them and because they are easily cleaned. The chamber is 7 in. (17.8 cm) deep from grid to top so that the mouse can neither jump out nor cling to the top edge of the wall in response to shock. The colors of the Plexiglas walls, white, black, and clear, are suited to our experimental situation and are of no general importance. The double wall arrangement on the drinking tube side of the chamber seems to have eliminated certain problems often encountered in contact relay applications. The animal can reach the tube only with its tongue and the tube can be adjusted for each subject which facilitates rapid acquisition of the response. Any unconsumed fluid flows down the outside wall and cannot make contact with the grid. White Plexiglas spacers are used as they provide a good background against which to view the location of the tip of the drinking tube. The 25/1000 in. (0.7 mm) gaps cut between rods in the grid prevent urine flow across the Plexiglas surface and thereby prevent short circuits during shock presentations. The grid is constructed of stainless steel rods which are easily cleaned and little affected by chewing. The entire unit is placed on paper toweling to collect urine and feces.

Responses are detected using a Lehigh Valley contact relay (LVE #1520 drinkometer). The contact circuit from the grid floor to the drinking tube is completed when the subject's tongue touches the tube.

The drinking tube is a stainless steel tube with an outside diameter of  $\frac{5}{16}$  in. (8.0 mm) and an inside diameter of  $\frac{1}{4}$  in. (6.4 mm). The tip of the tube has

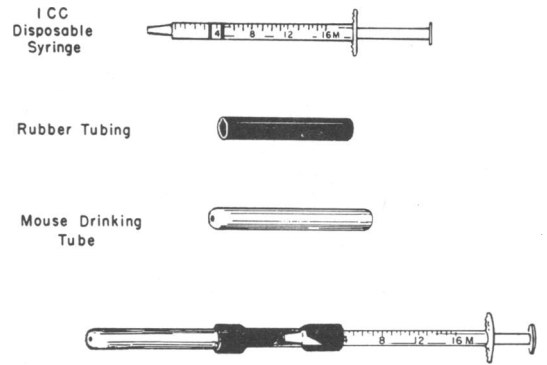

Fig. 3. Diagram of drinking tube-syringe arrangement for presentation of reinforcement.

been rolled down to leave a hole of  $\frac{5}{64}$  in. (1.9 mm) and polished with jeweler's rouge to minimize roughness.

The grid portion of the drinkometer circuit should be disconnected when shocks are presented through the grid floor. This can be accomplished using a 12-pole, double-throw relay, by connecting the rods in the grid to the 12 common positions, the shock source output to the 12 normally open poles of the relay, and the contact relay circuit to all 12 normally closed poles of the relay. The relay should then be operated by the same pulse that operates the shock source. Some arrangement of this type is mandatory if a grid scrambling device is used in the shock circuit.

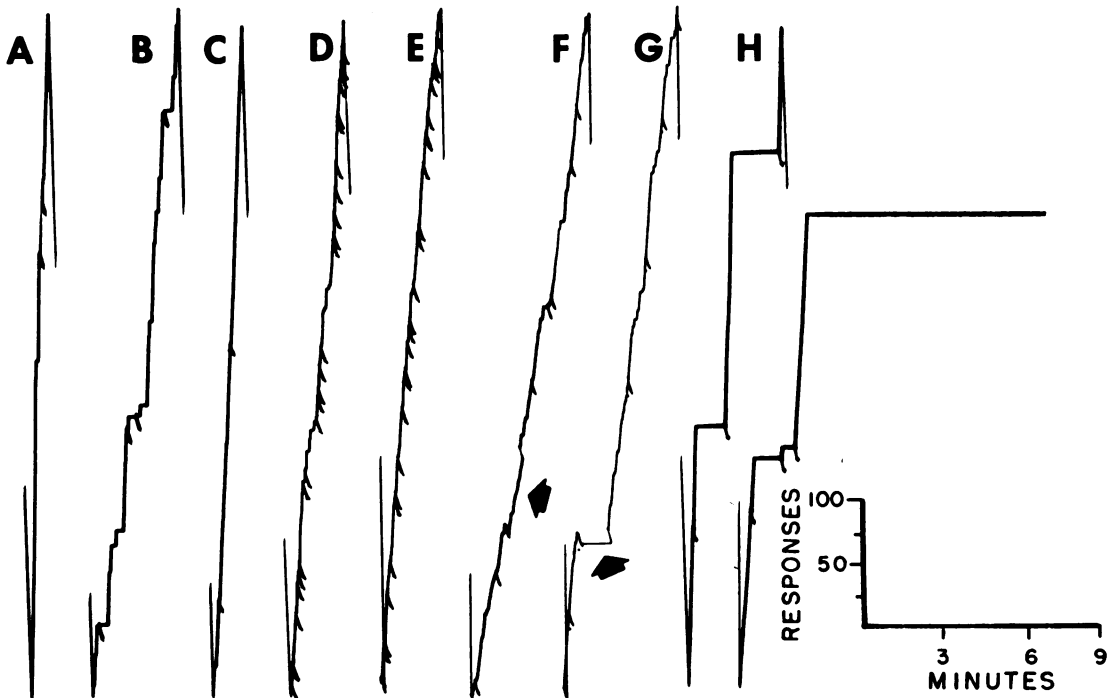

Fig. 4. Selected segments of cumulative records produced by laboratory mice in the licking operant chamber. See text for explanation.

Liquid reinforcement is presented through the licking tube, which is connected to a 1 cc disposable syringe as shown in Fig. 3. The plunger of the syringe is driven by an automatic syringe pump (Sage Instrument Co. #234-4). Magnitude of reinforcement can be varied by varying the duration of pump operation, the speed of plunger movement, the diameter of the syringe, or any combination of these variables. Currently, 0.005 cc per reinforcement is used as a standard magnitude value. Two liquid reinforcers are currently in use. Condensed milk, sweetened with sugar, and diluted with water, is used with mice that are given dry food supplements after each daily session (67% milk + 20% sugar + 13% water, by weight). Mice maintained solely on liquid diets are given a mixture of similac and dextri-maltose (80% similac, 20% dextri-maltose by weight).<sup>2</sup>

Six chambers are currently in use in behavior genetic studies using inbred strains of mice, and in food regulation studies using genetically obese (*ob/ob*) and diabetic (*db/db*) mice. Figure 4 shows selected samples of cumulative records obtained in these experiments. Segment A shows the responses of DBA/2J mouse on a variable-interval 30-sec schedule of reinforcement. The very high rate and absence of pauses are typical of the behavior of this mouse strain on this schedule. Segment B shows the behavior of a C57BL/6J mouse on the same schedule. The greater frequency of pauses is typical of C57BL/6J mice on this schedule. Segment C shows the behavior of a C57BL/6J mouse carrying the obese mutant gene (*ob/ob*) on the same schedule. Segments D and E show the behavior of a DBA/2J and a C57BL/6J mouse respectively on a variable-ratio 20 schedule of reinforcement. On this schedule, frequent short pauses are more characteristic of DBA/2J behavior than of C57BL/6J behavior. Seg-

ments F and G show the behavior of a C57BL/6J mouse when the Estes-Skinner procedure (conditioned suppression) is superimposed on a variable-interval 30-sec baseline. The arrow in segment F denotes the occurrence of the preshock stimulus (buzzer) during a session when shock was absent. The arrow in segment G denotes the occurrence of the preshock stimulus during a session when a 1-sec, 3-MA shock occurred with termination of the preshock stimulus. The two segments labeled H show the behavior of a diabetic mouse (*db/db*) on a variable-interval 30-sec schedule of reinforcement. The high rate of responding, interrupted by long pauses, giving an on-off-on-off appearance to the cumulative record, is a reliable indicator of the onset of terminal decline in these animals.

## REFERENCES

- Corbit, J. D. and Luschei, E. S. Invariance of the rat's rate of drinking. *Journal of Comparative and Physiological Psychology*, 1969, **69**, 119-125.
- Fisher, G. L. Saline preference in rats determined by contingent licking. *Journal of the Experimental Analysis of Behavior*, 1965, **8**, 295-303.
- Fuller, J. L. Effect of drinking schedule upon alcohol preference in mice. *Quarterly Journal of Studies on Alcohol*, 1967, **28**, 22-26.
- Sidman, M., Ray, B. A., Sidman, R. O., and Klinger, J. M. Neurological mutant mice: A method for preliminary evaluation of hearing and vision. *Experimental Neurology*, 1966, **16**, 377-402.
- Stellar, E. and Hill, J. H. The rat's rate of drinking as a function of water deprivation. *Journal of Comparative and Physiological Psychology*, 1952, **45**, 96-107.

RICHARD L. SPROTT  
FRANK W. CLARK  
RICHARD E. WIMER<sup>3</sup>  
*The Jackson Laboratory*

<sup>2</sup>The authors wish to thank Dr. John L. Fuller for the development of a liquid diet suitable for maintenance of diabetic and obese mice, and for his advice throughout the development of this research. Similac, Ross Laboratories; Dextri-Maltose, Mead Johnson Laboratories.

<sup>3</sup>Now at City of Hope Medical Center, Duarte, California 91010.