

## CHOICE BETWEEN RELIABLE AND UNRELIABLE REINFORCEMENT ALTERNATIVES REVISITED: PREFERENCE FOR UNRELIABLE REINFORCEMENT

TERRY W. BELKE AND MARCIA L. SPETCH

HARVARD UNIVERSITY AND UNIVERSITY OF ALBERTA

Pigeons' choices between a reliable alternative that always provided food after a delay (i.e., 100% reinforcement) and an unreliable one that provided food or blackout equally often after a delay (i.e., 50% reinforcement) was studied using a discrete-trials concurrent-chains procedure modified to prevent choice between alternatives following a blackout outcome. Initial links were fixed-ratio 1 schedules, and terminal links were fixed-time schedules. Stimuli presented during the terminal-link delays were correlated with the food and blackout outcomes. In Experiment 1, terminal-link durations were varied. With short terminal links (i.e., 10 s), 6 of 8 subjects showed strong preference for the 50% side. As terminal-link duration increased to 30 s, preference, regardless of direction, became less extreme. In Experiment 2, the side-key location of the 50% and 100% alternatives was reversed for 3 subjects. Preference for the 50% alternative reoccurred following the key reversal. When a 5-s separation was subsequently interposed between the initial and terminal links for both alternatives, all birds reversed to a preference for the 100% side. In general, the strong preference for the 50% side was qualitatively consistent with the expectation that the procedure enhanced the conditioned-reinforcement effectiveness of the food-associated terminal-link stimulus on the 50% side. Implications of the results for various accounts of choice of the 50% alternative are discussed.

*Key words:* choice, percentage reinforcement, signaled outcomes, conditioned reinforcement, delay reduction, delayed reinforcement, concurrent chains, key peck, pigeons

Previous investigations of choice using a percentage reinforcement concurrent-chains procedure have produced results inconsistent with molar reinforcement maximization. In the typical procedure, subjects choose between a reliable alternative that always produces food reinforcement after a fixed delay (i.e., 100% reinforcement) and an unreliable alternative that produces either food reinforcement or blackout with equal probability after a fixed delay (i.e., 50% reinforcement). Exclusive choice for 100% reinforcement minimizes the average interreinforcement interval, a result that is consistent with maximization of the rate of primary reinforcement. In contrast, choice of the 50% alternative increases the interreinforcement interval, a result that is inconsistent with reinforcement maximization.

Several studies have found conditions under which the 50% reinforcement alternative is chosen. Kendall (1974, 1985) found that preference for the 50% alternative varied with signal condition. When terminal-link stimuli on the 50% alternative were correlated with outcomes (i.e., signaled), subjects preferred the 50% alternative. When stimuli were not correlated with the outcomes (i.e., unsignaled), subjects strongly preferred the 100% alternative. Dunn and Spetch (1990) showed that under signaled conditions with long terminal links (i.e., 50 s), preference for the 50% alternative varied inversely with duration of the initial-link phase. As the initial-link schedule changed from a fixed-ratio (FR) 1 to variable-interval (VI) 80 s, choice of the 50% alternative declined. Spetch, Belke, Barnet, Dunn, and Pierce (1990) found that under signaled conditions with FR 1 initial links, preference for the 50% alternative varied with terminal-link duration. As terminal-link duration increased from 5 or 10 s to 30 s, choice of the 50% alternative increased. Further increases in terminal-link duration beyond 30 s did not systematically affect preference.

To account for this suboptimal choice of the 50% alternative, Dunn and Spetch (1990) and Spetch et al. (1990) proposed an explanatory framework based on Fantino's (1969) delay-

---

Portions of these results were presented at the Association for Behavior Analysis meeting in San Francisco in May 1992. The research was conducted in the operant research laboratory of the Department of Psychology at Harvard University. The first author is currently in the Department of Psychology at the University of Alberta on a Natural Sciences and Engineering Research Council of Canada postdoctoral fellowship. Correspondence and reprint requests should be addressed to Terry Belke, Department of Psychology, Biological Sciences Building, University of Alberta, Edmonton, Alberta T6G 2E9, Canada (E-mail: TBELKE@CYBER.PSYCH.UALBERTA.CA).

reduction hypothesis of conditioned reinforcement. The specific account they proposed will be described more fully in the General Discussion. For present purposes, one aspect of their framework is relevant, namely that the conditioned-reinforcement effectiveness of the onset of a terminal-link stimulus depends on local context. Specifically, they proposed that signaled periods of extinction on the 50% alternative provide a context that serves to enhance the effectiveness of the S+ (i.e., stimulus associated with food) on that alternative as a conditioned reinforcer of choice. Under certain temporal parameters, this enhanced effectiveness of the 50% S+ as a conditioned reinforcer is thought to override the tendency to choose the alternative that provides more primary reinforcement (i.e., the 100% alternative).

In the concurrent-chains procedure used in previous studies (Dunn & Spetch, 1990; Spetch et al., 1990), the signaled periods of extinction (i.e., the terminal links leading to blackout) could only occur following choice of the 50% side, but they could precede choice of either side. That is, following a blackout, the pigeon could either stay on the 50% side or switch to the 100% side. Thus, the proportion of extinction periods that preceded onset of the S+ on the 50% side or the 100% side varied depending on the pigeons' choice behavior. If the occurrence of signaled extinction periods does provide a context that enhances the effectiveness of a signal for food, then the difference between the context in effect for the 100% S+ and the context in effect for the 50% S+ might be even greater if pigeons were not permitted to switch sides following a blackout. Under these conditions, pigeons might show an even stronger tendency to choose the 50% alternative.

Accordingly, the present study investigated choice between 50% and 100% reinforcement in a procedure that prevented pigeons from switching to the 100% side following a blackout outcome on the 50% side. Specifically, after a blackout outcome on the 50% alternative, the subject was returned to the initial link, but with only the initial-link stimulus for the 50% alternative available. Only after food reinforcement on the 50% alternative was the opportunity to choose between the alternatives presented. This change in the procedure eliminated the termination of a chain of blackout outcomes on the 50% alternative with a food

outcome on the 100% alternative. To the extent that this change in the procedure increased the difference in conditioned-reinforcement effectiveness of the terminal-link stimuli, greater preference for the 50% alternative was expected.

## EXPERIMENT 1

### METHOD

#### *Subjects*

Subjects were 8 adult homing pigeons. The birds were maintained at 80% of their free-feeding body weights. Water and grit were freely available in the home cages. All subjects had extensive histories of exposure to operant conditioning procedures, but none had previously been exposed to the present type of procedure.

#### *Apparatus*

An operant conditioning chamber equipped with five horizontally aligned keys was used for this experiment. The chamber was 53 cm deep, 51 cm wide, and 30 cm long and was located within a plywood shell insulated with foam rubber to reduce extraneous noise. Response keys were 2 cm in diameter, 6 cm apart, center to center, and 22 cm above the wire mesh. Each response key could be transilluminated from the rear and required 0.15 N of force to operate. Only the second and fourth (from the end of the row) of the five keys were used in the present experiment.

Reinforcement was 4-s access to a milo and wheat mix. The feeder opening was 5 cm high and 34 cm long and was located 5 cm above the wire mesh floor. An electric motor raised and lowered the feeder. The feeder was illuminated and the keylights and houselights were extinguished during reinforcement. The chamber was illuminated by two white lights mounted on the sides of the chamber 4 cm from the top. A ventilation fan masked noise and circulated air within the chamber. A PDP-8A<sup>®</sup> computer (Digital Equipment Corp.) controlled experimental events and recorded data.

#### *Procedure*

Because all birds had extensive experience in operant conditioning procedures, no preliminary training was necessary. Figure 1 depicts

the concurrent-chains procedure used in the present study. During the initial link, Keys 2 and 4 were illuminated with a white light. A single response on either key completed the FR 1 initial-link requirement, initiated the terminal link signaled by a change in the color of the key, and rendered the other key dark and inoperative. The terminal-link component ended with an outcome (i.e., a 4-s food presentation or a 4-s blackout period) according to a fixed-time (FT) schedule. For Experiment 1, the reliable (100%) alternative was on Key 4 (i.e., right side of chamber) and the unreliable (50%) alternative was on Key 2 (i.e., left side of the chamber). On the 100% reinforcement alternative, the terminal link was signaled by a red light, and 4 s of food reinforcement always occurred when the terminal-link duration elapsed. On the 50% side, the initial-link peck produced either a stimulus associated with food reinforcement (i.e., a green light) or a stimulus associated with a blackout outcome (i.e., a yellow light). The probability that an initial-link peck on the 50% side would produce the food-reinforcement stimulus was .5 for every peck. A 1-s intertrial interval (all lights out) occurred between the termination of an outcome and the next presentation of initial-link stimuli.

To differentiate the procedure from that used in previous studies (e.g., Spetch et al., 1990), the following change was made. If the subject obtained a blackout stimulus on the 50% side, the terminal link elapsed and the blackout occurred. Following the blackout, the subject returned to the initial link, but with only the initial-link key for the 50% alternative available. A single response on this key met the FR 1 initial-link requirement and produced either the stimulus ( $S^-$ ) associated with blackout or the stimulus ( $S^+$ ) associated with food. The subject remained on this alternative until an initial-link peck on the 50% alternative produced the stimulus associated with food reinforcement. Thus, the subject was given the opportunity to choose between alternatives only after food reinforcement.

The effect of terminal-link duration on choice between the two alternatives was tested with two groups of 4 pigeons. In Group 1, all subjects were exposed to terminal-link durations of 10 s, 30 s, and 50 s. The baseline condition was a 10-s terminal-link duration for Subjects 267 and 437 and a 30-s duration

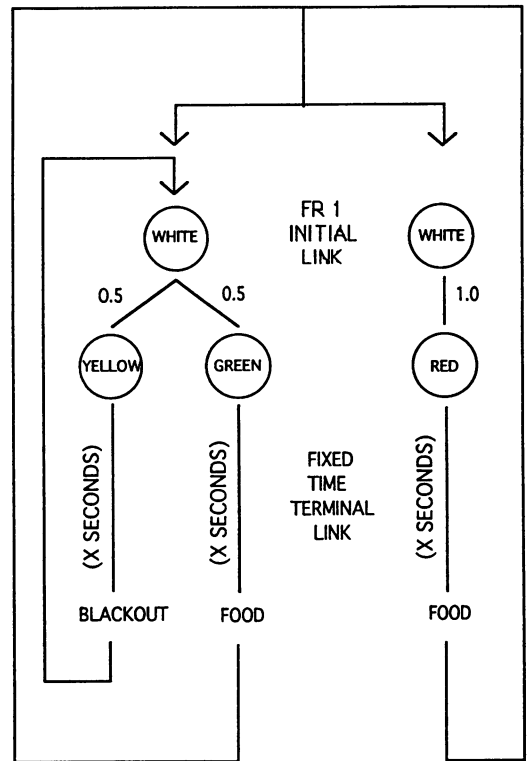

Fig. 1. Illustration of the percentage reinforcement concurrent-chains procedure used in the present study. The letter x specifies the duration of the fixed-time terminal link that was the same for all terminal links.

for Subjects 249 and 460. For Subjects 267 and 437, the order of conditions was 10 s, 30 s, 10 s, 50 s, and 10 s. For Subjects 249 and 460, the order of conditions was 30 s, 10 s, 30 s, 50 s, and 30 s.

In Group 2, all 4 subjects were exposed to terminal-link durations of 10 s, 30 s, and 10 s. Subjects in this group were subsequently exposed to a fourth condition that entailed a procedural variation designed to assess whether preference was influenced by the forced-choice pecks required to the initial-link stimulus on the 50% alternative following blackout. Accordingly, the procedure was changed so that only a single initial-link peck on the 50% side per food reinforcement was required. Upon presentation of the choice between the 50% side and the 100% side, a single peck on the 50% side initiated the following sequence of events. The peck produced either the stimulus associated with the blackout outcome or the stimulus associated with food reinforcement.

Table 1

Choice proportions (CP) for the 50% reinforcement alternative (with standard error values in parentheses), number of sessions to stability (S), minimum and maximum choice proportions over the first 15 sessions of a condition, terminal-link response rates for the food-associated stimulus on the 100% alternative (S+), the food-associated stimulus on the 50% alternative (S+), and the blackout-associated stimulus on the 50% alternative (S-) across terminal-link (TL) durations (in seconds) for each subject in Group 1.

| Bird | TL duration | CP         | S  | Max  | Min | TL responses (pecks per minute) |        |        |
|------|-------------|------------|----|------|-----|---------------------------------|--------|--------|
|      |             |            |    |      |     | 100% S+                         | 50% S+ | 50% S- |
| 267  | 10          | .13 (.01)  | 20 | .76  | .04 | 3.34                            | 4.52   | 1.65   |
|      | 30          | .57 (.02)  | 46 | .76  | .08 | 1.87                            | 1.36   | 0.61   |
|      | 10          | .99 (.01)  | 16 | 1.00 | .14 | 10.00                           | 5.81   | 2.26   |
|      | 50          | .67 (.03)  | 29 | 1.00 | .44 | 0.93                            | 0.52   | 1.46   |
|      | 10          | .99 (.01)  | 16 | 1.00 | .96 | 5.25                            | 5.40   | 1.88   |
| 437  | 10          | 1.00 (.00) | 17 | 1.00 | .54 | 0.00                            | 129.41 | 7.58   |
|      | 30          | .90 (.03)  | 21 | 1.00 | .80 | 25.91                           | 64.50  | 2.05   |
|      | 10          | .97 (.01)  | 15 | 1.00 | .86 | 2.14                            | 67.55  | 5.12   |
|      | 50          | .80 (.02)  | 15 | .92  | .68 | 1.54                            | 31.22  | 0.94   |
|      | 10          | .99 (.01)  | 15 | 1.00 | .70 | 2.00                            | 98.68  | 4.53   |
| 249  | 30          | .88 (.02)  | 36 | .94  | .04 | 5.04                            | 9.87   | 1.44   |
|      | 10          | .99 (.01)  | 37 | .78  | .00 | 15.00                           | 37.69  | 3.52   |
|      | 30          | .83 (.04)  | 29 | 1.00 | .82 | 10.76                           | 14.89  | 1.36   |
|      | 50          | .90 (.01)  | 17 | .94  | .58 | 18.47                           | 23.04  | 1.63   |
| 460  | 30          | .16 (.02)  | 30 | .82  | .12 | 3.28                            | 3.78   | 1.57   |
|      | 10          | .02 (.01)  | 15 | .16  | .00 | 2.97                            | 5.00   | 2.00   |
|      | 30          | .09 (.02)  | 37 | .32  | .00 | 0.27                            | 1.61   | 0.86   |
|      | 50          | .21 (.02)  | 15 | .34  | .06 | 0.57                            | 1.36   | 0.74   |
|      | 30          | .17 (.01)  | 22 | .24  | .06 | 0.33                            | 2.79   | 1.35   |

If the stimulus preceded the blackout outcome, the duration of the terminal link timed out and the blackout period ensued, but at the termination of the blackout period, the computer selected either the blackout stimulus or the food reinforcement stimulus on the 50% side as if an initial-link peck had been made. The chain of blackout terminal links continued until the stimulus associated with food reinforcement occurred. After food reinforcement, the subject was returned to the initial link with both initial-link stimuli available. The terminal-link duration was 10 s during this condition. One of the 4 subjects failed to complete this condition in the time available for this experiment.

The dependent variable was the proportion of initial-link responses for the 50% alternative when both alternatives were available. Preference was judged to be stable in a condition if the means of each three-session block from the last nine sessions did not differ by more than  $\pm .05$  and showed neither an upward ( $M1 < M2 < M3$ ) nor a downward ( $M1 > M2 > M3$ ) trend. The mean choice proportion for the 50% side over the nine sessions that met

these criteria was taken as the stable performance value for a condition. Criteria for stability were first applied after 15 sessions of a condition had been completed. Response rates in the terminal links were also recorded. Sessions ended when 50 food reinforcements had been obtained.

## RESULTS

Detailed results for each subject of Groups 1 and 2 are presented in Tables 1 and 2, respectively. The tables show the choice proportions at stability and number of sessions to reach stability for each condition. Minimum and maximum choice proportions over the first 15 sessions in each condition show that both alternatives were typically sampled prior to attainment of the stability criteria. Terminal-link response rates in the presence of the 100% S+, 50% S+, and 50% S- stimuli are also shown.

Figure 2 portrays choice proportions for all 8 subjects in the 10-s and 30-s terminal-link conditions. In cases in which multiple determinations of the choice proportions at a given terminal-link duration were made, the data

Table 2

Choice proportions (CP) for the 50% reinforcement alternative (with standard error values in parentheses), number of sessions to stability (S), minimum and maximum choice proportions over the first 15 sessions of a condition, and terminal-link response rates for the food-associated stimulus on the 100% alternative (S+), the food-associated stimulus on the 50% alternative (S+), and the blackout-associated stimulus on the 50% alternative (S-) across terminal-link (TL) durations (in seconds) for each subject in Group 2.

| Bird | TL duration | CP        | S  | Max  | Min | TL responses (pecks per minute) |        |        |
|------|-------------|-----------|----|------|-----|---------------------------------|--------|--------|
|      |             |           |    |      |     | 100% S+                         | 50% S+ | 50% S- |
| 30   | 10          | .78 (.03) | 28 | .56  | .00 | 12.40                           | 40.03  | 1.04   |
|      | 30          | .57 (.04) | 28 | .80  | .26 | 1.19                            | 6.99   | 0.77   |
|      | 10          | .85 (.03) | 28 | 1.00 | .18 | 15.13                           | 15.44  | 0.65   |
| 422  | 10          | .98 (.01) | 18 | 1.00 | .10 | 28.00                           | 65.84  | 0.01   |
|      | 30          | .60 (.03) | 70 | 1.00 | .26 | 13.25                           | 13.76  | 0.12   |
|      | 10          | .99 (.01) | 15 | 1.00 | .90 | 12.00                           | 22.42  | 0.02   |
| 428  | 10          | .96 (.01) | 31 | .82  | .48 | 0.00                            | 27.35  | 6.86   |
|      | 30          | .93 (.02) | 48 | 1.00 | .60 | 1.85                            | 7.35   | 1.19   |
|      | 10          | .98 (.01) | 15 | 1.00 | .90 | 2.40                            | 10.45  | 3.53   |
| 377  | 10          | .15 (.03) | 38 | .96  | .16 | 22.18                           | 121.35 | 3.00   |
|      | 30          | .48 (.05) | 38 | .74  | .06 | 0.31                            | 3.41   | 1.22   |
|      | 10          | .29 (.02) | 40 | .50  | .08 | 6.73                            | 10.85  | 3.99   |

point for that duration was the average over all determinations. In the 10-s terminal-link condition, 6 of 8 birds showed a strong to extreme preference for the 50% alternative. When the terminal-link duration was increased to 30 s, preference for this alternative declined. In contrast, Pigeon 460 in Group 1 and Pigeon 377 in Group 2 preferred the 100% alternative in the 10-s condition, and preference for this alternative declined when the terminal-link duration was increased to 30 s. Thus, although the direction of the preference at the short terminal-link duration varied across subjects, preference for an alternative became less extreme as terminal-link duration increased from 10 s to 30 s. For the subjects in Group 1, when the terminal-link duration was increased to 50 s, no systematic changes in preference occurred (Table 1). Pigeons 249 and 460 increased choice of the 50% alternative, and Pigeons 267 and 437 decreased choice of the 50% alternative.

Figure 3 shows the choice proportions when an initial-link response was required after every outcome on the 50% side (i.e., response required) and when only a single response on the 50% alternative was required to initiate a chain of outcomes that terminated with food reinforcement (i.e., response not required). Terminal-link duration for both conditions was 10 s. The results show that this manipulation,

which altered the number of initial-link responses on the 50% alternative required for food reinforcement, had little effect on choice proportions.

In general, absolute response rates to the terminal-link stimulus associated with food on the 50% alternative were higher than response rates to the terminal-link stimulus on the 100% reinforcement alternative. To quantify this observation, a ratio of terminal-link response rates was calculated for each subject: response rate on the 50% food stimulus divided by the response rate on the 50% food stimulus plus the response rate on the 100% food stimulus. Scores above .5 indicate higher response rates to the 50% S+ stimulus, and scores below .5 indicate higher response rates to the 100% S+ stimulus.

Figure 4 shows this terminal-link ratio for each subject at terminal-link durations of 10 and 30 s. At both terminal-link durations, the ratios for most subjects were greater than .5. Statistical analysis of these terminal-link ratios revealed that ratios were significantly higher than .5 for the 10-s [ $M = .72$ ,  $t(7) = 3.9$ ] and the 30-s [ $M = .70$ ,  $t(7) = 3.3$ ] terminal-link durations, but failed to reach statistical significance for the 50-s terminal-link duration [ $M = .64$ ,  $t(3) = 1.15$ ]. Although mean terminal-link response-rate ratios and mean initial-link choice proportions both favored the 50% alternative, there was no relation between

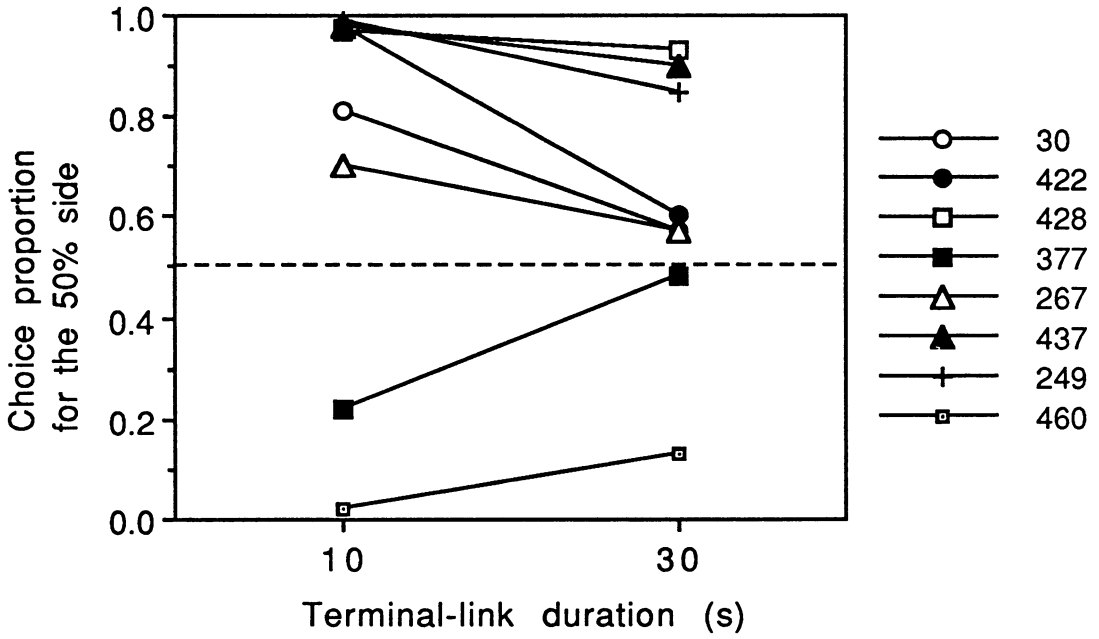

Fig. 2. Choice proportions for the 50% reinforcement alternative at terminal-link durations of 10 and 30 s for subjects in Groups 1 and 2.

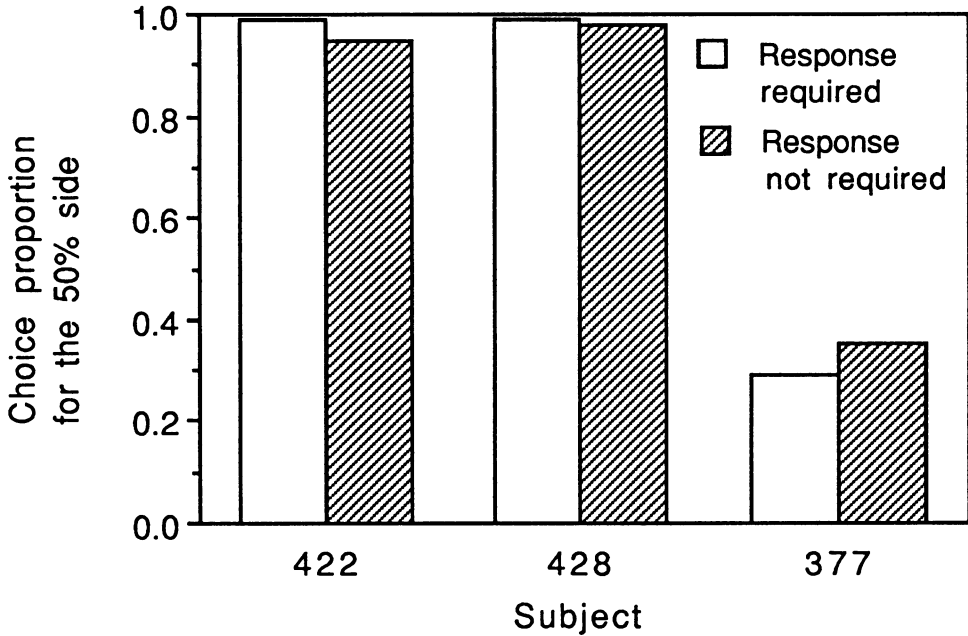

Fig. 3. Choice proportions for the 50% reinforcement alternative for 3 subjects in Group 2 when an initial-link response was and was not required after each blackout outcome on the 50% alternative.

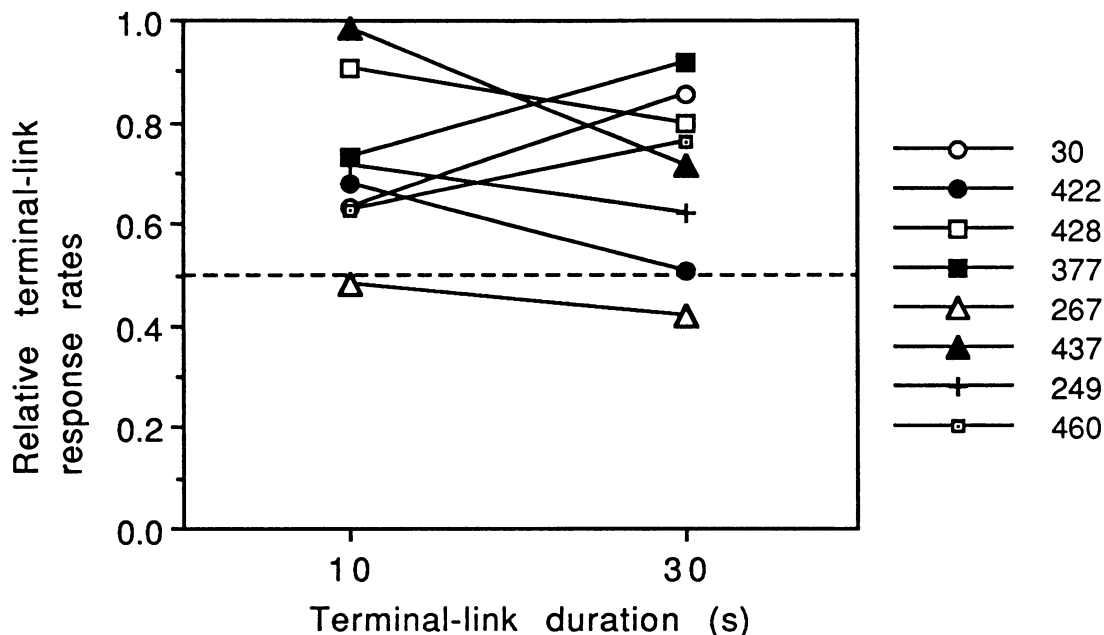

Fig. 4. Relative terminal-link response-rate ratios for each subject at terminal-link durations of 10 and 30 s. Values above .5 indicate higher response rates to the 50% S+ stimulus, and scores below .5 indicate higher response rates to the 100% S+ stimulus.

the terminal-link ratios and choice proportions. For example, Subjects 460 and 377 both showed a preference for the 100% alternative but produced terminal-link ratios favoring the 50% S+ stimulus. Furthermore, in contrast to choice proportions, changes in terminal-link duration from 10 to 30 s did not produce any systematic changes in terminal-link response-rate ratios.

#### DISCUSSION

The results share both similarities to and differences from the findings of Spetch et al. (1990). In both studies, the observed preferences were inconsistent with maximization of primary reinforcement as a primary determinant of preference. In the present study, the tendency to choose the 50% side was more extreme than that observed by Spetch et al. (1990). Second, the finding that S+ terminal-link response rates were higher on the 50% side than on the 100% side and that terminal-link response rates were not correlated with initial-link preferences is consistent with findings by Spetch, Mondloch, Belke, and Dunn (1994). Third, across-subject variability was consistent with previous studies. This variability is consistent with the notion that be-

havior is determined by more than one factor and that individual subjects may show differential relative sensitivity to these factors. Finally, terminal-link duration is an important variable in both procedures, but the nature of the effect may be different. In the present procedure, increases in terminal-link duration from a short to a longer duration appeared to make preferences less extreme. In contrast, with the procedure used by Spetch et al. (1990), similar increases in terminal-link duration generally increased choice of the 50% side. Although some birds in our previous studies could be characterized as showing less extreme preferences with longer terminal links, there were also several birds that showed a reversal of preference (Spetch et al., 1990, 1994).

In general, the absolute levels of preference in the present procedure are comparable to those observed in the previous procedure when terminal-link durations are long, but are quite different when terminal-link durations are short (Spetch et al., 1990). The stronger preference for the 50% alternative observed in the present study, especially at short terminal links, may reflect enhanced conditioned-reinforcement effects resulting from the change in procedure, which ensured that blackout terminal

links never directly preceded choice of the 100% side.

## EXPERIMENT 2

Experiment 1 showed that the majority of subjects displayed a strong preference for the 50% alternative, especially when the terminal-link duration was short. One potential explanation for this apparent preference for the 50% alternative is side bias. Kendall (1974, 1985) found that preference for the 50% alternative recovered after side reversal, which suggests that the preference is not due to side bias. In the present study, the possibility of a side bias was tested by switching the location of the 50% alternative from the left side (Key 2) to the right side (Key 4) for 3 subjects that had previously shown a strong preference for the 50% side in Experiment 1.

A second manipulation investigated the effect of separating initial-link responses from terminal-link stimuli by interposing a 5-s period between the initial and terminal links during which time the key was dark and inoperative. If preference for the 50% alternative is a function of the conditioned-reinforcement value associated with the onset of the terminal-link stimulus, then separating the initial-link responses from the onset of the terminal-link stimulus should degrade the conditioned-reinforcement effect of the terminal-link stimulus.

## METHOD

### *Subjects*

Subjects were 3 adult homing pigeons used in Experiment 1 that showed a strong preference for the 50% alternative. Experiment 2 was conducted approximately 1 year after Experiment 1, and these subjects had intervening experience in other operant chambers using a different procedure. Four other subjects from the first experiment were being used in other experiments, and 1 had died. The birds were maintained at 80% of their free-feeding body weights. Water and grit were freely available in the home cages.

### *Apparatus and Procedure*

The apparatus was the same as that used in Experiment 1. The basic procedure was the same as that used in Experiment 1, in which initial-link responses were required after

blackout outcomes. In the first condition, the 50% alternative was located on Key 2 and the 100% alternative was on Key 4, as in Experiment 1. In the second condition, the side-key positions of the 50% and 100% alternatives were reversed. In both conditions, the terminal-link durations were 10 s, and the key colors associated with the 100% and 50% alternatives were the same as in Experiment 1.

The manipulation that involved a 5-s separation of initial and terminal links followed the side-reversal manipulation. In this procedure, completion of the initial-link requirement on either alternative produced a 5-s period during which both keys were dark and inoperative. After 5 s elapsed, the terminal-link stimulus appeared on the key with which the initial-link requirement was met and the 10-s terminal-link FT schedule began. Each bird received a minimum of 15 sessions under each condition. The stability criteria were the same as those in Experiment 1.

## RESULTS

Figure 5 shows choice proportions for the 50% alternative across sessions for the side-reversal manipulation. Prior to the reversal, all 3 pigeons replicated their preference for the 50% alternative observed in Experiment 1. Following the reversal, 2 of the 3 pigeons rapidly shifted preference back to the 50% side. Pigeon 428 took longer to shift back to a preference for the 50% alternative and only recovered to a moderate level of preference.

Table 3 presents each bird's choice proportions for the 50% alternative averaged over the nine sessions that met the stability criteria when the 50% alternative was on the left, when the 50% alternative was on the right, and when initial-link responses and terminal-link stimuli were separated by 5 s. Table 3 also shows that, as seen in Experiment 1, terminal-link response rates in the presence of the 50% S+ terminal-link stimulus were generally higher than in the presence of the 100% S+ terminal-link stimulus. Mean terminal-link ratios for the 50% alternative on the left, 50% alternative on the right, and 5-s separation conditions were .59, .83, and .78, respectively. These ratios were statistically higher than .5 for the 50% alternative on the right condition [ $t(2) = 4.4$ ] but not for the 50% on the left [ $t(2) = 0.78$ ] and 5-s separation [ $t(2) = 3.1$ ] conditions. The results also show that there was no relation



between relative rates of responding to the terminal-link stimuli and choice proportions in the initial link. When the 5-s separation was introduced, terminal-link response rates continued to be higher on the 50% S+ than on the 100% S+, despite a strong shift in initial-link choice proportions toward preference for the 100% alternative.

#### DISCUSSION

The results from the side-reversal manipulation discount side bias as a viable explanation of the observed preference for the 50% alternative. Preference followed the 50% alternative as it was shifted from the left to the right side of the chamber. This result replicates Kendall's (1974, 1985) finding that preference for the 50% alternative recovered following side reversal.

The temporal separation of initial-link responses from terminal-link stimuli produced a strong shift in preference toward the 100% alternative. This shift in preference toward the 100% alternative is similar to that observed when conditions are changed from signaled outcomes to unsignaled outcomes. For example, Spetch et al. (1990) observed a weak preference for the 50% side when the terminal-link stimuli on the 50% alternative were correlated with outcomes (i.e., signaled) but found a strong preference for the 100% alternative when terminal-link stimuli on the 50% alternative were no longer correlated with the outcomes (i.e., unsignaled). In the present study, the 5-s separation on the 50% side was not differentially associated with either outcome. Therefore, our 5-s separation condition may have been functionally like an unsignaled procedure, because darkened keys during the separation period that followed initial-link pecks were not predictive of the outcome.

#### GENERAL DISCUSSION

The results underscore the inadequacy of molar maximization of primary reinforcement as an explanation for preference in this procedure. Because choice of the 50% alternative increases the interreinforcement interval, a strong preference for the 50% alternative results nearly in reinforcement minimization rather than maximization. Nevertheless, in the present study, most subjects strongly preferred the 50% alternative, particularly in the 10-s

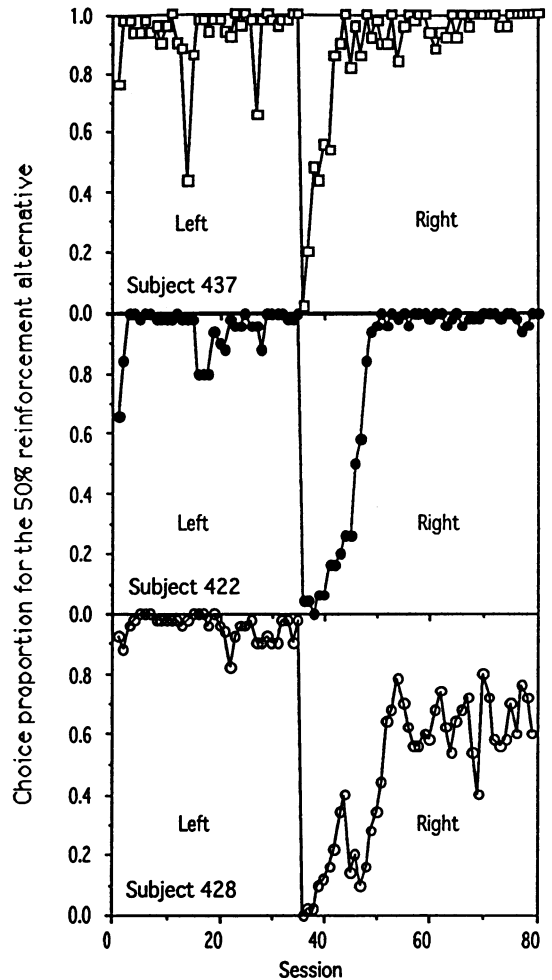

Fig. 5. Choice proportions for the 50% reinforcement alternative across sessions when the 50% alternative was on the left side (Key 2) and on the right side (Key 4).

terminal-link conditions. The results of Experiment 2 suggested that preference for the 50% alternative was not due to a side bias. Preference for the 50% alternative did, however, appear to require that the terminal-link stimuli, which signaled the outcomes, be presented immediately following the choice peck. When onset of all terminal-link stimuli was delayed for 5 s, preference shifted dramatically to the 100% alternative. These results point to the need to attend to the role played by the signals associated with the outcomes and other contextual factors as determinants of preference.

Certain aspects of the present results are similar to those originally reported by Kendall

Table 3

Choice proportions (CP) for the 50% reinforcement alternative (with standard error values in parentheses), number of sessions to stability (S), and terminal-link response rates for the food-associated stimulus on the 100% alternative (S+), the food-associated stimulus on the 50% alternative (S+), and the blackout-associated stimulus on the 50% alternative (S-) for the side-reversal and 5-s separation conditions for each subject.

| Bird | Condition      | CP        | S  | TL responses (pecks per minute) |        |        |
|------|----------------|-----------|----|---------------------------------|--------|--------|
|      |                |           |    | 100% S+                         | 50% S+ | 50% S- |
| 437  | 50% on left    | .95 (.01) | 23 | 5.35                            | 13.59  | 1.42   |
|      | 50% on right   | .93 (.02) | 20 | 6.17                            | 13.10  | 1.95   |
|      | 5-s separation | .30 (.04) | 21 | 4.94                            | 13.26  | 0.21   |
| 422  | 50% on left    | .99 (.02) | 15 | 25.33                           | 14.23  | 0.00   |
|      | 50% on right   | .99 (.01) | 23 | 4.00                            | 39.19  | 0.16   |
|      | 5-s separation | .28 (.03) | 19 | 16.97                           | 32.03  | 0.19   |
| 428  | 50% on left    | .98 (.00) | 15 | 7.33                            | 16.47  | 3.18   |
|      | 50% on right   | .63 (.04) | 36 | 1.03                            | 9.36   | 2.02   |
|      | 5-s separation | .10 (.01) | 21 | 0.15                            | 3.28   | 0.00   |

(1974). As in the present study, Kendall found that pigeons strongly preferred a 50% alternative over a 100% alternative under certain conditions. He demonstrated that this preference was not due to a side bias and that it occurred only when terminal-link stimuli on the 50% side were correlated with the food and no-food outcomes. However, he used an unusual procedure in which the pecking keys were darkened during the initial links (cf. Fantino, Dunn, & Meck, 1979). Presumably for that reason, his findings received little attention until a more recent series of experiments (Dunn & Spetch, 1990; Kendall, 1985; Spetch et al., 1990) confirmed that pigeons will choose a 50% alternative far more frequently than expected on the basis of reinforcement maximization. However, until now, none of the more recent studies replicated the strong preference for the 50% alternative originally reported by Kendall (1974). The present study, which shows another procedure in which most pigeons strongly prefer a 50% alternative, suggests that Kendall's findings were not completely anomalous.

In previous studies of choice with probabilistic outcomes in the concurrent-chains procedure, pigeons have been free to choose between the 100% and 50% alternative following each outcome, whether it be food or blackout. This means that a blackout outcome could be followed by another choice of the 50% side or by a switch to a choice of the 100% side. It also means that the actual average delay to a food outcome following choice of the 50% side

could vary depending on the pigeon's subsequent choice behavior. In the procedure used here, the pigeons were permitted free choice of the two alternatives only after food outcomes. Consequently, they could not switch to the 100% alternative after a blackout outcome. This ensured that the signaled periods of extinction were always terminated eventually with an S+ period on the 50% side. This procedural change ensured that the average delay to food following choice of the 50% side was independent of subsequent choice behavior.

There are several similarities and a few differences between the results obtained with the present procedure and those previously obtained. The first similarity is that, as noted above, pigeons did not respond so as to maximize primary reinforcement. The present study showed an even stronger tendency of most pigeons to choose the 50% side than has been found in all previous studies except that of Kendall (1974) and, like Kendall, ruled out side bias as a plausible explanation. Second, as reported by Spetch et al. (in press), most pigeons made more terminal-link responses during the S+ on the 50% side than during the S+ on the 100% side, despite the fact that both of these terminal-link stimuli signaled the identical absolute delay to food. Moreover, in both the study by Spetch et al. (in press) and the present study, this difference in rates on the 50% S+ and the 100% S+ was obtained whether or not pigeons preferred the 50% alternative. Third, the dramatic shift in preference to the 100% alternative shown by the

3 subjects in Experiment 2 when onset of the terminal-link stimuli was delayed may be consistent with two earlier findings. First, Dunn and Spetch (1990) found that choice of the 50% alternative decreases when the choice phase was lengthened, a manipulation that delayed onset of the terminal-link stimuli following their first choice peck. Second, several previous studies showed that choice of the 50% alternative is substantially lower if the terminal-link stimuli do not signal which outcome will be presented after the delay on the 50% side. In the present study, the 5-s delay to onset of the terminal-link stimuli meant that the choice peck was not immediately followed by stimuli that signaled the outcomes; this manipulation may therefore have been analogous to a procedure in which outcomes are not differentially signaled.

One apparent difference between the present results and those found with the previous procedure is in the effects of manipulating terminal-link duration. Although the present results agree with those obtained by Spetch et al. (1990, 1994) in showing that terminal-link duration affects preference, the nature of the effect appears to be somewhat different. Whereas the previous studies found that increases in terminal-link duration from short (5 or 10 s) to longer values increased pigeons' choice of the 50% alternative, the present study found that increases in the terminal-link duration made preferences less extreme. The 6 subjects with a preference for the 50% alternative showed more extreme choice of the 50% alternative when the terminal link was 10 s than when it was longer. Similarly, the 2 subjects with a preference for the 100% alternative showed more extreme levels of this preference at the 10-s terminal-link duration. In contrast to the findings of Spetch et al., none of the subjects showed preference reversals with increased terminal-link duration. This apparent difference in the nature of the effect of the terminal-link duration on choice between the present study and those of Spetch et al. may reflect the change in procedure. Determining why terminal-link duration affects choice differently in the two tasks remains a challenge for future research.

A related difference between the present results and those of Spetch et al. (1990, 1994) concerns the absolute levels of preference. In the present study, mean choice proportion for

the 50% alternative over the 8 pigeons in Experiment 1 was .71 in the 10-s terminal-link condition and .63 in the 30-s terminal-link condition. These values are comparable to those seen in the previous studies in the 30-s terminal-link condition, but are higher in the 10-s terminal-link condition. Thus, the present procedure seems to produce an enhanced tendency to choose the 50% alternative, most notably when terminal-link durations are short.

The increased tendency to choose the 50% alternative in the present procedure is consistent with our expectation that preventing switches to the 100% alternative following blackouts might make the contexts on the 50% and 100% alternatives particularly distinct, which in turn would enhance the effectiveness of the 50% S+ as a conditioned reinforcer. This expectation was derived from the local delay-reduction framework proposed by Dunn and Spetch (1990) and Spetch et al. (1990), which borrowed from Fantino's (1969) delay-reduction hypothesis. In brief, they suggested that choice is determined by both the primary reinforcement provided by each alternative and the conditioned reinforcement provided by onset of the terminal-link stimuli. Although primary-reinforcement effects favor the more reliable alternative, control by this factor is assumed to weaken as the outcomes become more delayed (i.e., as terminal-link duration increases). Conditioned-reinforcement effects are assumed to depend on the reduction in delay to food signaled by stimulus onset. With FR 1 initial links in a signaled procedure, onset of the 50% terminal link is thought to be more effective as a conditioned reinforcer than onset of the 100% terminal link because of differences in their local context. Specifically, the 50% S+ terminal link occurs in the context of sometimes getting the S- terminal link, and hence its onset signals a reduction in delay to reinforcement. In contrast, the 100% S+ terminal link always follows choice of the 100% alternative, and hence its onset signals little if any reduction in delay over that associated with the choice peck. Under these conditions, conditioned-reinforcement effects should lead to choice of the 50% side, and can produce preference for the 50% side under conditions in which they exert more control than primary-reinforcement effects.

Some aspects of the present results are consistent with this local delay-reduction frame-

work. First, because the present procedure should enhance the difference between the local contexts of the 50% and 100% alternatives, the stronger preference for the 50% alternative in the present study may be explained by enhanced conditioned reinforcing effectiveness of the 50% S+. Second, the reversal of preference from the 50% alternative to the 100% alternative produced by the separation of the initial and terminal links is consistent with this account because that manipulation should severely reduce or eliminate conditioned-reinforcement effects, such that choice would be controlled mainly or exclusively by the difference in primary reinforcement. However, the effect of increasing terminal-link duration in the present study does not fit well with the local delay-reduction framework proposed by Dunn and Spetch (1990). Within this account, the effect of increasing the terminal-link duration is to diminish effects of primary reinforcement on preference and thereby allow conditioned-reinforcement effects to exert more control. The decrease in preference for the 50% alternative observed in the present study appears to be inconsistent with this prediction. As such, the local delay-reduction framework does not seem to account for this aspect of the results observed in the present study.

Mazur's (1989, 1991) hyperbolic decay model is a second framework that has been used to account for choice with probabilistic outcomes. According to this model, the value of a conditioned reinforcer is a function of the delay to primary reinforcement. Value decreases hyperbolically with increasing delay, but only in the presence of stimuli associated with the primary reinforcer. Delays in the presence of stimuli not associated with reinforcement do not affect the value of conditioned reinforcers. According to this model, the delays associated with the blackout outcomes in the present procedure should have no effect on the value of the 50% alternative. Consequently, the value of the 50% and the 100% reinforcement alternatives with equal terminal-link delays to food reinforcement should be equal, and indifference should occur. The strong preference for the 50% alternative in this study cannot be accounted for by Mazur's model.

It has also been suggested (e.g., Dunn & Spetch, 1990) that pigeons' tendency to choose the 50% alternative may be related to effects observed with the serial autoshaping proce-

dures. Serial autoshaping studies (Collins & Pearce, 1985; Pearce & Hall, 1980) have demonstrated that more responses occur to a stimulus that is only sometimes followed by a stimulus that signals food than to a stimulus that is always followed by a stimulus that signals food. According to Collins and Pearce (1985), pigeons peck a stimulus that is intermittently followed by a food signal more than one that is reliably followed by a food signal because orienting responses vary inversely with the predictive accuracy of a conditional stimulus (CS). Generalizing this explanation to the results from the percentage-reinforcement procedure suggests that more observing responses should occur to the initial-link stimulus associated with the 50% reinforcement alternative than to the initial-link stimulus associated with the 100% reinforcement alternative. Although this explanation seems to be a plausible account for preference for the 50% alternative, evidence suggests that increased response rates during individual stimulus presentations do not necessarily translate into increased preference during choice procedures. Pearce and Collins (1987) used probes to test preference between stimuli that were intermittently or perfectly predictive of a stimulus associated with food. Results showed that preference in the probes was opposite the direction of the response-rate difference when the stimuli were presented individually. Furthermore, Fantino and Case (1993) found that initial-link response rates on an informative 50% reinforcement alternative were higher than those on an uninformative 100% reinforcement alternative when these alternatives were presented successively. However, when they were presented concurrently, the uninformative 100% reinforcement alternative was preferred to the informative 50% side. Note, however, that these studies did not use initial-link durations that appear to be most conducive to the development of a strong preference for the 50% alternative (cf. Dunn & Spetch, 1990). Thus, it remains unclear whether serial autoshaping and preference for 50% reinforcement are related phenomena.

It is also interesting to consider the present results in terms of two hypotheses proposed by Kendall (1974) as potential explanations for the preferences for the 50% side observed in his study. According to a "value enhancement" hypothesis, the more time that is spent in the presence of a stimulus associated with non-

reinforcement (i.e., a negative stimulus), the greater the value of a positive stimulus when it alternates with this negative stimulus. In the present procedure, time associated with nonreinforcement on the 100% alternative would be the time spent in the initial link, and time associated with reinforcement would be the time spent in the presence of the food stimulus. For the 50% alternative, time associated with nonreinforcement would include time spent in the initial links and the blackout terminal links, and time associated with reinforcement would be time spent in the presence of the food-associated stimulus. This hypothesis makes predictions similar to the local delay-reduction explanation under many conditions. Moreover, this view predicts an enhanced difference between the values of the 50% and 100% alternatives when the blackout terminal links precede only the 50% S+ and never the 100% S+, as in the present procedure.

However, Spetch et al. (1994) recently found that preference for the 50% alternative did not vary with the duration of the stimulus that signaled blackout. This suggests that the time spent in the presence of stimuli associated with blackout may not be important, although the occurrence or frequency of the timeout periods may be important. It is not known whether the duration of the signaled terminal link leading to blackout would affect preference in the present procedure. A second problem for Kendall's value hypothesis is that Dunn and Spetch (1990) found no enhancement of preference for the 100% alternative when the same stimulus (a red light on the center key) signaled onset of the food terminal link following choice of either the 50% or the 100% alternative, compared to the standard procedure in which the 50% and 100% terminal-link stimuli were distinct. In the same-stimulus case, any enhanced value of the S+ provided by the S- periods should have equally affected choice of the 50% and 100% alternatives. Those results suggested that enhancement effects produced by the S- periods might be better conceptualized as an increase in the effectiveness of the S+ as a conditioned reinforcer than as an increase in its "value." That is, the same stimulus might function effectively as a conditioned reinforcer in a lean context but not in a richer context (cf. Dunn & Spetch, 1990).

Kendall's (1974) alternative "contrast" hy-

pothesis was that the occurrence of time associated with nonreinforcement prior to the time associated with reinforcement might produce an aftereffect that enhances responding. In other words, the signaled blackout time that preceded the occurrence of a stimulus associated with food would be equivalent to an extinction component in a multiple schedule. The present procedure might be expected to enhance any such contrast effects because it ensured that the signaled periods of extinction never preceded the 100% S+. However, this emphasis on times that precede the positive stimulus seems contrary to Williams's (1979) finding that response rates in multiple schedules are affected more reliably by the following than the preceding schedule. Nevertheless, both preference for the 50% alternative and the higher rates of responding to the 50% S+ than to the 100% S+ suggest that the occurrence of the signaled blackout periods in some way enhances responding for the S+ and responding to the S+. A remaining puzzle is why preference and terminal-link responding are both enhanced by the occurrence of signaled periods of extinction and yet are independent of each other.

In sum, each of the explanatory frameworks proposed to date accounts well for some aspects of our results, but none provides a completely satisfactory account of both the previous findings and the full set of results reported here. Whether accommodation of the full set of results will require a new explanatory account or a modification or merger of the existing ones remains to be determined. In either case, the strong preference for the 50% reinforcement alternative observed in the present research indicates that the phenomenon first observed by Kendall (1974) is reliable. Understanding this preference is a challenge that must be addressed by any comprehensive model of choice.

## REFERENCES

- Collins, L., & Pearce, J. M. (1985). Predictive accuracy and the effects of partial reinforcement on serial autoshaping. *Journal of Experimental Psychology: Animal Behavior Processes*, *11*, 548-564.
- Dunn, R., & Spetch, M. L. (1990). Choice with uncertain outcomes: Conditioned reinforcement effects. *Journal of the Experimental Analysis of Behavior*, *53*, 201-218.

- Fantino, E. (1969). Choice and rate of reinforcement. *Journal of the Experimental Analysis of Behavior*, *12*, 723-730.
- Fantino, E., & Case, D. A. (1993). The delay-reduction hypothesis: Effects of informative events on response rates and choice. *The Quarterly Journal of Experimental Psychology*, *46B*, 145-161.
- Fantino, E., Dunn, R., & Meck, W. (1979). Percentage reinforcement and choice. *Journal of the Experimental Analysis of Behavior*, *32*, 335-340.
- Kendall, S. B. (1974). Preference for intermittent reinforcement. *Journal of the Experimental Analysis of Behavior*, *21*, 463-473.
- Kendall, S. B. (1985). A further study of choice and percentage reinforcement. *Behavioral Processes*, *10*, 399-413.
- Mazur, J. E. (1989). Theories of probabilistic reinforcement. *Journal of the Experimental Analysis of Behavior*, *51*, 87-99.
- Mazur, J. E. (1991). Choice with probabilistic reinforcement: Effects of delay and conditioned reinforcers. *Journal of the Experimental Analysis of Behavior*, *55*, 63-77.
- Pearce, J. M., & Collins, L. (1987). An evaluation of the associative strength of a partially reinforced serial CS. *The Quarterly Journal of Experimental Psychology*, *39B*, 273-293.
- Pearce, J. M., & Hall, G. (1980). A model for Pavlovian learning: Variations in the effectiveness of conditioned but not of unconditioned stimuli. *Psychological Review*, *87*, 532-552.
- Spetch, M. L., Belke, T. W., Barnet, R. W., Dunn, R., & Pierce, W. D. (1990). Suboptimal choice in a percentage-reinforcement procedure: Effects of signal condition and terminal-link length. *Journal of the Experimental Analysis of Behavior*, *53*, 219-234.
- Spetch, M. L., Mondloch, M. V., Belke, T. W., & Dunn, R. (1994). Determinants of pigeon's choice between certain and probabilistic outcomes. *Animal Learning & Behavior*, *22*, 239-251.
- Williams, B. A. (1979). Contrast, component duration, and the following schedule of reinforcement. *Journal of Experimental Psychology: Animal Behavior Processes*, *5*, 379-396.

Received February 8, 1994

Final acceptance July 12, 1994