

*CONCURRENT-CHAIN PERFORMANCE: EFFECTS OF
ABSOLUTE AND RELATIVE TERMINAL-LINK
ENTRY FREQUENCY*

BRENT ALSOP AND MICHAEL DAVISON

UNIVERSITY OF AUCKLAND, NEW ZEALAND

Six pigeons were trained in a concurrent-chain procedure with constant variable-interval 6-s variable-interval 12-s terminal links. Five groups of conditions were arranged. Within a group of conditions, the duration of one initial-link schedule was held constant and the duration of the other initial link was varied. The duration of the varied initial link was always longer than, or equal to, the constant initial-link duration. The duration of the shorter initial link was varied across groups of conditions from 5 s to 70 s. The data from each group were well described by the generalized matching law. Sensitivity (a) to the terminal-link entry ratio increased as the shorter initial-link duration increased, but appeared to reach an asymptote at shorter initial-link durations greater than 32 s. Terminal-link bias did not change with changes in shorter initial-link duration for the response-allocation data, but showed a small increase with increasing shorter initial-link duration for the time-allocation data.

Key words: concurrent-chain schedules, generalized matching law, sensitivity to entry frequency, bias, response allocation, time allocation, key peck, pigeons

Free-operant studies of choice often employ either concurrent schedules or concurrent-chain schedules. In a concurrent schedule, two or more schedules of reinforcement are simultaneously available. Subjects' allocation of behavior between these concurrent alternatives measures preference for one schedule over the others.

A concurrent variable-interval variable-interval (VI VI) schedule typically consists of the initial links of a concurrent-chain schedule. Completion of an initial-link schedule leads to the exclusive presentation of an additional schedule that terminates in a single food reinforcer. The delivery of food by this terminal-link schedule may be response independent (e.g., fixed delay—FD) or response dependent (e.g., VI). Once a terminal link is completed, the concurrent VI VI initial links are reinstated (Figure 1). Preference for one terminal link over the other is measured by subjects' allocation of behavior during the concurrent alternatives available during the initial links.

These two procedures bear obvious similarities; that is, a concurrent-chain schedule is but a concurrent schedule with the reinforcement period extended in time, or, conversely, a concurrent schedule is but a concurrent-chain schedule where both terminal links are 0 s in duration. Davison (1983) suggested that these similarities justify an empirical approach to concurrent-chain performance based on our understanding of concurrent-schedule performance.

Concurrent-schedule performance is typically described using the generalized matching law (Baum, 1979). This can be written as

$$\log\left(\frac{B_1}{B_2}\right) = a \log\left(\frac{R_1}{R_2}\right) + \log c, \quad (1)$$

where B denotes responses, R denotes obtained reinforcers, and the subscripts 1 and 2 denote the two response alternatives. The parameter a is called sensitivity to reinforcer frequency and measures the amount of change in the log response ratio as a function of changes in the log reinforcer ratio. A similar relation is found if time allocation ($\log T_1/T_2$) is used as the dependent variable in place of response allocation (e.g., Baum & Rachlin, 1969). Typically, a is approximately 0.7 to 0.9 (termed undermatching; Baum, 1979), which means that the subjects' behavior is less sensitive to

We thank the New Zealand University Grants Committee for equipment grants to Michael Davison and for the postgraduate scholarship that allowed Brent Alsop to continue his research; we also thank the staff and students who helped run this experiment and Dr. John A. Nevin for his comments on an earlier version of this manuscript. Reprints may be obtained from Brent Alsop or Michael Davison, Department of Psychology, University of Auckland, Private Bag, Auckland, New Zealand.

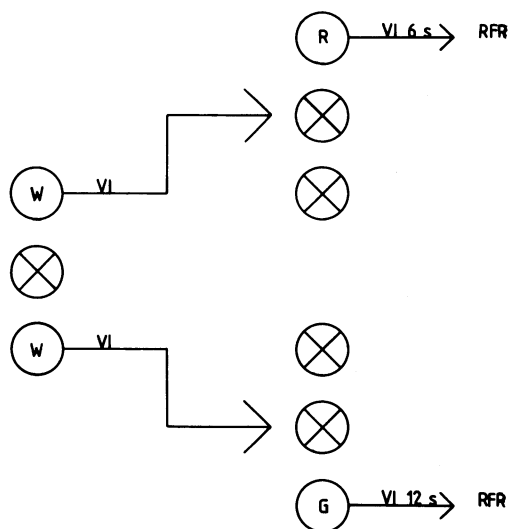

Fig. 1. A schematic diagram of a concurrent-chain procedure with VI terminal links (see text for description).

changes in the reinforcer ratio than a strict matching relation ($a = 1$) demands. The parameter $\log c$ is called bias and is interpreted as a preference for one alternative due to some inequality between the two alternatives that remains unchanged throughout the experiment.

The generalized matching law can describe performance where more than one independent variable is manipulated in the concurrent schedule. For example, following Baum and Rachlin (1969), the effects of different response forces (Hunter & Davison, 1982) or qualitatively different reinforcers (Hollard & Davison, 1971) may be accounted for simply by adding the logarithm of the ratio of these variables into Equation 1. Davison (1983) proposed that such an additive logarithmic model may be used to investigate empirically performance in concurrent-chain experiments. This model took the form

$$\log\left(\frac{B_{1i}}{B_{2i}}\right) = a \log\left(\frac{R_{1i}}{R_{2i}}\right) + b \log\left(\frac{D_{2t}}{D_{1t}}\right) + \log c, \quad (2)$$

where B , a , $\log c$, 1, and 2 are the same as in Equation 1, and R now denotes obtained terminal-link entries (and hence obtained rein-

forcers), and D denotes the delay in the terminal links before reinforcers are delivered. The subscripts i and t denote initial-link and terminal-link events, and the parameter b denotes sensitivity to variations in the arranged terminal-link schedules. The treatment of terminal-link effects in Equation 2 is similar to the treatment of the effects of reinforcer magnitude and reinforcer delay proposed by Baum and Rachlin (1969) and the treatment of the effects of qualitatively different reinforcers by Hollard and Davison (1971).

Although the description of concurrent-chain performance given by Equation 2 separates the main effects of initial-link contingencies and terminal-link contingencies, it also can measure interactions between these contingencies. These appear as systematic variations in the sensitivity parameters (a and b in Equation 2) as a function of some other variable in the concurrent-chain procedure; for example, the absolute duration of the initial-link schedules relative to the absolute duration of the terminal-link schedules may affect a and b . Previous research suggests that such effects do occur in concurrent-chain schedules. Fantino (1969) showed that preference between two constant terminal links moved towards indifference as the absolute duration of equal initial-link schedules was increased. Williams and Fantino (1978) showed that preference between two fixed-interval terminal links, always in a ratio of 2:1, became more extreme as the absolute duration of the terminal links was increased. Similar systematic changes in parameters such as a and b can be found in data from concurrent-schedule research; for example, experiments using concurrent schedules to investigate stimulus disparity (Miller, Saunders, & Bourland, 1980) and effects of reinforcer magnitude (Davison & Hogsden, 1984).

However, Davison (1987) found that Equation 2 did not fit the data from a large number of previously reported concurrent-chain experiments. He suggested that this may be due to differences in the manner in which concurrent-chain schedules and concurrent schedules are typically arranged. First, he noted that changeover delays (CODs) are thought to be a potent controlling variable in concurrent-schedule performance (de Villiers, 1977). A COD in a concurrent schedule is a period of time (usually 2 s to 5 s) following the first re-

sponse on an alternative, after responding on the other alternative, during which no reinforcer can be obtained. Some experimenters (e.g., de Villiers, 1977) maintain that the absence of a COD in a concurrent schedule tends to decrease sensitivity to the obtained relative reinforcer rate (a in Equation 1). However, the COD has rarely been used in the initial links of concurrent chains to preclude a terminal-link entry for a certain period of time after a changeover. Second, the concurrent VI VI schedules in the initial links are usually arranged independently; that is, when one schedule arranges a reinforcer, other reinforcers still can be obtained on the alternative schedule. This can lead to major discrepancies between the arranged and the obtained relative frequency of terminal-link entry on the two alternatives, and can lead to covariation of the independent variable (relative terminal-link entry frequency) with changes in the dependent variable (relative response rate) (Davison & Temple, 1973; Snyderman, 1983). However, Fantino and Royalty (1987) found little difference between the results from concurrent-chain schedules arranging independently scheduled or nonindependently scheduled initial links.

Davison (1983) arranged the initial links of his concurrent-chain schedule in the same way that concurrent schedules are usually arranged. In Experiment 1, he used nonindependent concurrent VI VI initial links (Stubbs & Pliskoff, 1969) with a 3-s COD. The terminal links were FD schedules. When conditions sharing the same shorter initial link (SIL) and constant terminal links were grouped together, the data within each group were well described by Equation 2. All five groups had SILs of 30 s, and the terminal links ranged from 0 s versus 0 s to 15 s versus 30 s. Although the sensitivities to the terminal-link entry ratio (a in Equation 2) were at the lower end of the range of values usually obtained from concurrent schedules (Baum, 1979), there were no systematic changes in the a values across the five groups; that is, a was independent of changes in the terminal-link schedules.

Sensitivity to the terminal-link schedules (b in Equation 2) was constant across groups of conditions sharing the same shorter terminal link (e.g., 0 s vs. 0 s, 3 s, 5 s, 10 s, or 30 s), but increased with increases in the duration of the shorter terminal-link schedule (e.g., 15 s vs.

30 s). This implies that preference is not solely determined by the ratio of the terminal-link delays, but also by their absolute duration, an implication also consistent with the results of Duncan and Fantino (1970). These changes in b , while a remains constant, are consistent with approaches that attribute terminal-link effects to changes in the "value" of primary reinforcers (or in the conditioned reinforcement associated with terminal-link entry) as some nonlinear function of the delay until reinforcement.

The results from Experiment 2 of Davison (1983) add additional complications to such an approach. Here, the terminal links were always FD 15 s and FD 30 s. The 3-s COD remained in effect, but the concurrent VI initial links were scheduled independently. Three sets of conditions were arranged, each set employing a different SIL (0 s, 30 s, and 60 s). Equation 2 fitted the data well, suggesting that the nonindependent scheduling arranged in Experiment 1 was not important. Sensitivity to the terminal-link entry ratio (a) appeared to be lower for the SIL 0-s than for the SIL 30-s and SIL 60-s sets of conditions, but this effect was not statistically significant. However, as only three SIL durations were arranged, and one of these employed a rather unusual 0-s initial link, the effect of SIL duration on sensitivity to the terminal-link entry ratio was unclear.

However, the bias produced by the constant, unequal, terminal links decreased as the SIL duration increased; that is, sensitivity (b) to the ratio of terminal-link schedules was not simply a function of terminal-link duration but also of initial-link duration. This finding presents difficulties for any simple model of terminal-link effects in terms of either conditioned reinforcement or decayed value of food reinforcers because it requires these effects to be attenuated by some relation between initial-link and terminal-link durations. On the other hand, the results from Experiments 1 and 2 still provide some simplification of concurrent-chain performance. Changes in preference produced by changes in the absolute durations of the initial- and terminal-link schedules (e.g., Fantino, 1969; Squires & Fantino, 1971) appeared to be attributable solely to changes in sensitivity to the terminal-link contingencies, whereas sensitivity to the initial-link contingencies was unaffected.

The present experiment is a replication and extension of Davison's (1983) study. First, it attempted to replicate the finding that arranging a COD and dependent scheduling in the initial links of a concurrent chain allows groups of conditions sharing the same SIL to be analyzed by the generalized matching law (Equation 2), and to show that Davison's results were not simply the product of fortuitous selection of conditions. Furthermore, rather than using FD terminal-link schedules as in Davison (1983), the present study used VI terminal-link schedules. The results of previous concurrent-chain research on periodic and aperiodic schedules (e.g., Killeen, 1968), and response-dependent and response-independent schedules (e.g., Neuringer, 1969), suggest that this change should not affect the usefulness of Equation 2 as a tool to assess concurrent-chain performance.

Second, and more importantly, the present experiment investigated the effects of initial-link duration on sensitivity to initial-link and terminal-link schedules (respectively, a and b in Equation 2) with constant, unequal, terminal links. The results from Experiment 2 of Davison (1983) were not compelling, especially considering it used only three different SIL durations and that one of these was an SIL 0-s group of conditions. The present study arranged five different SIL durations, ranging from 5 s to 70 s.

METHOD

Subjects

Six homing pigeons, numbered 161 to 166, were maintained at $85\% \pm 15$ g of their free-feeding body weights. All subjects had previous histories of responding on free-operant procedures but had no prior exposure to concurrent-chain schedules. Water and grit were freely available in their home cages at all times.

Apparatus

Solid state experimental control equipment and impulse counters, situated remote from the experimental chamber, controlled all experimental events and recorded the data. The chamber (33 cm high, 33 cm wide, and 31 cm deep) was fitted with an exhaust fan to provide ventilation and to help mask external noise. The chamber contained three response keys, 2 cm in diameter, 11 cm apart, and 25 cm

above the grid floor. The left key could be transilluminated either white or red, and the right key either white or green. The center key was dark and inoperative throughout the experiment. When lit, the keys were operated by pecks exceeding about 0.1 N, each of which produced a feedback-relay click. Pecks on darkened keys were ineffective and were not counted.

The food magazine was situated beneath the center key, 12 cm from the grid floor. During reinforcement (a nominal 3-s access to wheat) the hopper was raised and illuminated and the keylights were extinguished. There were no other sources of illumination in the chamber.

Procedure

Because the pigeons were experienced with free-operant procedures, no shaping was necessary. First, the subjects were trained for 33 sessions on single VI schedules using a variety of keys and colors. Then they were placed on a concurrent-chain schedule similar to that used in Condition 1 (Table 1), except that the COD was only 0.05 s. Over the next 44 sessions, the duration of this COD was increased to 3 s; that is, when an entry into a terminal link was arranged, a response on the appropriate key produced the terminal link only if 3 s had elapsed since the first response on that key following the last response to the other key. The first experimental condition then began.

The general procedure used in the experiment is shown in Figure 1. During the concurrent initial links, both side keys were transilluminated white, and each was correlated with a VI schedule. These two schedules were arranged nonindependently, using a single VI timer. When an interval had completed timing, the timer stopped and entry into a terminal link was assigned probabilistically to either the left or right key, in the manner of Stubbs and Pliskoff (1969). The probability of assignment to either the left or right key could be varied to produce unequal VI schedules on the two keys. This procedure ensured that the relative frequency of terminal-link entry obtained would be the same as that arranged by the initial-link schedules.

When a response on the left key produced the terminal link, the right key was darkened, the left key was transilluminated red, and a reinforcer could be obtained on completion of a VI 12-s schedule. When a response on the

right key produced the terminal link, the left key was darkened, the right key was transilluminated green, and a reinforcer could be obtained on completion of a VI 6-s schedule. Following reinforcement, the initial-link timer was restarted and the initial-link schedules were again available. The VI schedules consisted of intervals randomized from the first 12 terms of an arithmetic progression $a, a + d, a + 2d, \dots$, where a was one twelfth the mean interval.

The sequence of experimental conditions, the number of training sessions in each, and the arranged initial-link VI schedules are shown in Table 1. The terminal links remained the same throughout the experiment. There were five sets of conditions, each set employing a different shorter initial-link VI schedule. In Conditions 2 to 6, one of the initial-link schedules was VI 32 s and the other initial link was longer than, or equal to, VI 32 s. In Conditions 7 to 11, one of the initial links was VI 10 s and the other initial link was longer than, or equal to, VI 10 s. In Conditions 1 and 12 to 16, one of the initial links was VI 56 s and the other initial link was longer than, or equal to, VI 56 s. Condition 13 was a replication of Condition 1. In Conditions 17, 18, 22, 23, and 24, one of the initial links was VI 5 s and the other longer than, or equal to, VI 5 s. In Conditions 19, 20, 21, 25, and 26, one of the initial links was VI 70 s and the other initial link was longer than, or equal to, VI 70 s.

Sessions began in blackout, and ended in blackout after either approximately 45 min had elapsed or after a predetermined number of entries into the terminal links had been obtained. The number of entries required to end the session for each condition is shown in Table 1. At the end of each daily session, four sets of data were recorded: The number of responses emitted to each key in the initial links, the time spent responding on each key in the initial links (measured from the first peck on one key to the first peck on the other), the number of entries into each terminal link, and the number of responses made to each key during the terminal links. After each experimental session, the pigeon was returned to its home cage and was fed the amount of mixed grain necessary to maintain its designated body weight.

Each experimental condition remained in

Table 1

Sequence of experimental conditions, VI schedules in the initial links, maximum number of entries per session, and the number of sessions per condition. VI schedules times are in seconds.

Condition	Initial links		Entries	Sessions
	Left	Right		
1	56	56	40	22
2	32	32	40	26
3	32	130	40	17
4	280	32	40	36
5	32	280	40	18
6	130	32	40	24
7	10	10	40	24
8	10	40	40	19
9	90	10	40	26
10	10	90	40	23
11	40	10	40	33
12	56	220	40	18
13	56	56	40	27
14	501	56	30	29
15	56	501	30	21
16	220	56	40	35
17	20	5	40	30
18	5	20	40	18
19	70	280	30	29
20	630	70	30	34
21	280	70	30	34
22	5	5	40	42
23	45	5	40	48
24	5	45	40	27
25	70	70	30	37
26	70	630	30	25

effect until all birds had reached a defined stability criterion five, not necessarily consecutive, times. This criterion was that the median relative initial-link response number over five sessions did not differ by more than .05 from the median of the five sessions prior to these. The data used in the analyses were from the last five sessions of training in each condition. Typically, when a bird had reached the stability criterion, preference remained stable until the experimental condition was changed.

RESULTS

The data used in the analyses were the number of responses emitted during, and time spent in, each initial-link alternative and the number of responses emitted during, and entries into, each terminal link, summed over the last five sessions of each condition for each bird. These data are shown in the Appendix.

The logarithms of the initial-link response

Table 2

Slopes (a in Equation 2) and intercepts ($b \log D_{2i}/D_{1i} + \log c$ in Equation 2), and their standard deviations (SD), for each subject in each least-squares linear regression. The percentage of the variance accounted for by the fitted line (VAC) is also shown. Data for both response allocation and time allocation are shown.

Bird	Responses			Time		
	Slope	Intercept	VAC	Slope	Intercept	VAC
Shorter initial link 5 s						
161	0.55 (0.09)	0.13 (0.06)	93	0.55 (0.05)	0.17 (0.04)	97
162	0.78 (0.10)	0.28 (0.07)	96	0.66 (0.03)	0.23 (0.03)	99
163	0.65 (0.09)	0.20 (0.06)	95	0.71 (0.04)	0.07 (0.02)	99
164	0.55 (0.05)	0.30 (0.04)	97	0.69 (0.06)	0.16 (0.05)	98
165	0.73 (0.13)	0.36 (0.11)	91	0.62 (0.10)	0.08 (0.08)	93
166	0.81 (0.04)	0.23 (0.03)	99	0.74 (0.02)	0.21 (0.01)	100
Shorter initial link 10 s						
161	0.52 (0.08)	0.19 (0.06)	93	0.70 (0.05)	0.18 (0.04)	98
162	0.53 (0.04)	0.57 (0.03)	98	0.55 (0.06)	0.33 (0.04)	97
163	0.58 (0.11)	0.47 (0.07)	90	0.71 (0.06)	0.16 (0.04)	98
164	0.65 (0.10)	0.52 (0.07)	93	0.68 (0.07)	0.18 (0.05)	97
165	0.66 (0.02)	0.26 (0.01)	100	0.73 (0.03)	0.09 (0.02)	100
166	0.60 (0.08)	0.25 (0.05)	95	0.71 (0.06)	0.20 (0.04)	98
Shorter initial link 32 s						
161	0.93 (0.08)	0.28 (0.05)	98	1.12 (0.13)	0.33 (0.08)	96
162	0.96 (0.29)	0.43 (0.19)	79	0.91 (0.16)	0.42 (0.11)	91
163	0.84 (0.09)	0.10 (0.06)	97	1.07 (0.09)	0.18 (0.06)	98
164	0.95 (0.09)	0.23 (0.06)	98	1.28 (0.13)	0.31 (0.09)	97
165	1.06 (0.12)	0.29 (0.09)	96	1.24 (0.15)	0.34 (0.12)	96
166	0.88 (0.07)	0.17 (0.05)	98	1.12 (0.08)	0.32 (0.05)	98
Shorter initial link 56 s						
161	0.88 (0.03)	0.19 (0.02)	100	0.96 (0.11)	0.32 (0.07)	95
162	0.63 (0.12)	0.22 (0.08)	87	0.63 (0.10)	0.38 (0.07)	90
163	0.73 (0.08)	0.24 (0.06)	95	0.91 (0.04)	0.37 (0.03)	99
164	1.11 (0.11)	0.33 (0.07)	96	1.28 (0.15)	0.37 (0.09)	95
165	0.98 (0.08)	0.35 (0.05)	98	1.17 (0.11)	0.36 (0.07)	97
166	0.85 (0.11)	0.15 (0.07)	94	0.90 (0.16)	0.36 (0.11)	89
Shorter initial link 70 s						
161	0.75 (0.14)	0.33 (0.11)	90	0.84 (0.12)	0.40 (0.09)	94
162	0.75 (0.03)	0.02 (0.02)	100	0.84 (0.03)	0.18 (0.02)	100
163	0.78 (0.13)	0.11 (0.09)	92	0.85 (0.20)	0.18 (0.14)	86
164	1.17 (0.08)	0.12 (0.06)	99	1.27 (0.10)	0.10 (0.08)	98
165	1.10 (0.07)	0.27 (0.05)	99	1.23 (0.14)	0.10 (0.10)	96
166	0.91 (0.07)	0.19 (0.05)	98	0.98 (0.07)	0.29 (0.05)	98

ratios, the initial-link time ratios, and the terminal-link entry ratios were calculated for each subject in each condition. There were no systematic differences between the data from Condition 1 and its replication, Condition 13 (Appendix). Log response ratios ($\log B_{1i}/B_{2i}$) were plotted against log entry ratios ($\log R_{1i}/R_{2i}$) for each subject in each set of conditions sharing the same shorter initial-link schedule, and the best fitting line was calculated using the method of least-squares linear regression. An identical analysis was conducted using the

time-allocation data ($\log T_{1i}/T_{2i}$), rather than the response-allocation data, as the dependent variable. The results of these 60 linear regressions are shown in Table 2.

The generalized matching law (Equation 2) described the data well. For the response-allocation analyses, 90% or more of the data variance was accounted for (VAC) by the fitted line in 28 of the 30 linear regressions. Bird 162 was the exception, with VACs of 79% and 87% for SIL 32 s and SIL 56 s, respectively. For the time-allocation analyses, again 28 of

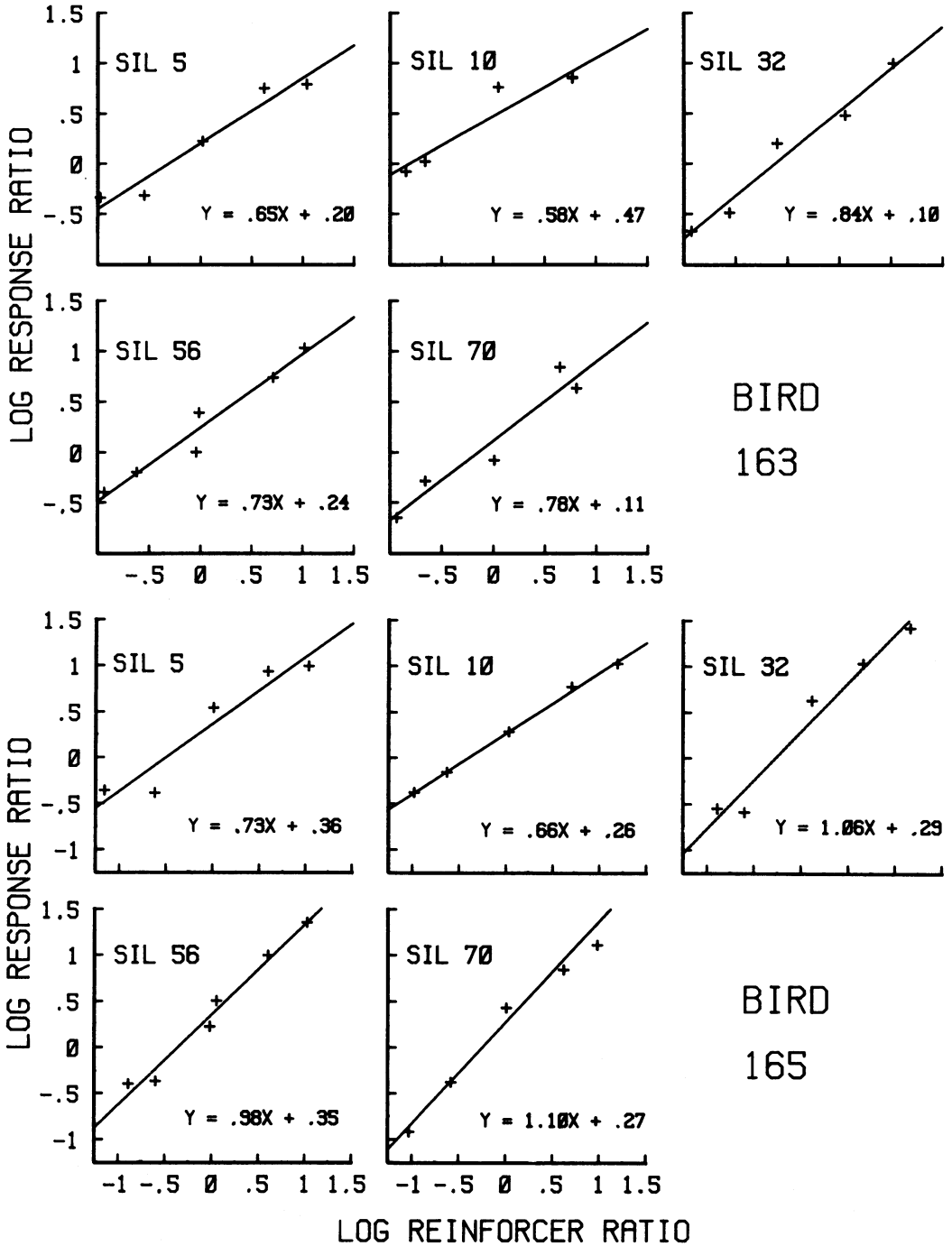

Fig. 2. Log response ratios ($\log B_1/B_2$) are plotted as a function of log obtained entry ratio ($\log R_1/R_2$) for each condition in each SIL group for Birds 163 and 165. The line of best fit calculated by the method of least-squares linear regression is also shown.

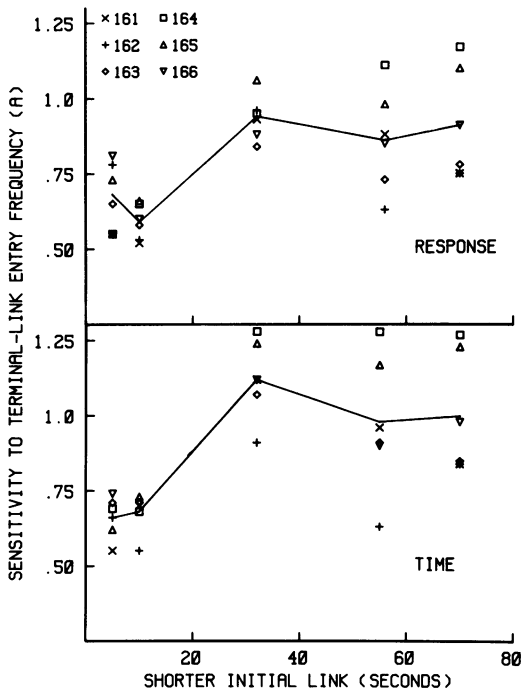

Fig. 3. Sensitivity to terminal-link entry ratio (a in Equation 2) plotted for each subject at each shorter initial-link duration. Response-allocation data are shown in the top panel and time-allocation data in the bottom panel. The mean sensitivity values across subjects at each shorter initial-link duration are joined.

the 30 linear regressions had VACs of 90% or greater. Bird 166 had a VAC of 89% for the conditions with SIL 56 s, and Bird 163 had a VAC of 86% with SIL 70 s. The standard deviations of the slopes and intercepts were quite small, and in general the data fit Equation 2 better than did the data from Experiment 2 of Davison (1983). Plots of the data showed no systematic deviations from the matching relation expressed in Equation 2 across subjects or across the different shorter initial links. Plots of the response-allocation data across the five SIL durations are shown for two randomly selected subjects (Birds 163 and 165) in Figure 2.

The sensitivities to the terminal-link entry ratio (a in Equation 2) for both time- and response-allocation data were similar to the a values typically obtained from concurrent schedules (e.g., Baum, 1979). Response-allocation a values ranged from 0.52 (Bird 161, SIL 10 s) to 1.17 (Bird 164, SIL 70 s), and the time-allocation a values ranged from 0.55 (Bird 161, SIL 5 s; Bird 162, SIL 10 s) to 1.28

(Bird 164, SILs 32 s and 56 s). At smaller SIL durations (5 s and 10 s), the sensitivities were slightly lower than those usually reported for concurrent-schedule performance (0.8 to 0.9; Baum, 1979). At larger SIL durations, the a values were well within the usual concurrent-schedule range and, if anything, were at the high end of this range. There were four instances of overmatching (a values greater than 1.0; Baum, 1979) among the 30 response-allocation sensitivities and nine instances of overmatching among the 30 time-allocation sensitivities.

The sensitivity of initial-link performance to the terminal-link entry ratio (a in Equation 2) from each of the SIL groups is plotted as a function of the SIL duration for both the response- and time-allocation data in Figure 3. Sensitivity increased as the length of the shorter initial link increased. A nonparametric trend test (Ferguson, 1965) across subjects and SIL durations was significant for both the response-allocation data ($\Sigma S = 28$, $p < .05$) and the time-allocation data ($\Sigma S = 22$, $p < .05$). Although the results of the monotonic trend tests were significant, Figure 3 suggests that the effect of increasing SIL duration may have reached an asymptote at the longer SIL durations. For example, Birds 161, 162, and 163 had highest response-allocation a values at SIL 32 s, whereas the remaining birds had highest a values at SIL 70 s. For the time-allocation data, 5 subjects had their maximum a values at SIL 32 s, whereas Bird 164 had a slightly higher a value at SIL 56 s.

Concurrent-schedule research has demonstrated that time-allocation sensitivities (a in Equation 1) tend to be higher than their corresponding response-allocation sensitivities (e.g., Baum, 1979). The present experiment showed the same pattern. For 25 of 30 possible comparisons, the time-allocation a values were higher than the response-allocation a values. This result was significant on a Sign Test ($z = 3.65$, $p < .05$; Siegel, 1956). Four of the five comparisons that give the converse result occurred when the SIL was 5 s, suggesting that the usual relationship between response and time measures of choice may not have been constant over the entire range of SIL durations. However, when the response-allocation a values were subtracted from the time-allocation a values for each subject in each SIL group, a trend test showed no significant in-

crease in the difference between these two measures of choice with increasing SIL duration.

Figure 4 shows the response- and time-allocation measures of bias ($b \log D_{2t}/D_{1t} + \log c$ in Equation 2) for each subject at each SIL duration. For the response-allocation data, there were no systematic changes in bias with increasing SIL duration. Because the terminal-link schedules (D_{2t} and D_{1t} in Equation 2) were kept constant, and assuming that inherent bias ($\log c$ in Equation 2) remained constant across conditions, sensitivity to the terminal-link schedules (b in Equation 2) was independent of the SIL duration. Biases ranged from -0.02 (Bird 162, SIL 70 s), to 0.57 (Bird 162, SIL 10 s), whereas the mean biases across subjects were $0.25, 0.38, 0.25, 0.25,$ and 0.17 for SILs of 5 s, 10 s, 32 s, 56 s, and 70 s, respectively. These are similar to the bias predicted by the arranged VI 6-s and VI 12-s terminal links ($\log D_{2t}/D_{1t} = 0.30$).

However, time-allocation measures of bias increased significantly as the SIL increased ($\Sigma S = 28, p < .05$). The biases ranged from 0.07 (Bird 165, SIL 5 s) to 0.42 (Bird 162, SIL 10 s) and the mean values across subjects were $0.15, 0.19, 0.32, 0.36,$ and 0.21 for the five increasing SIL durations. Assuming the other term comprising the bias ($\log c$ in Equation 2) remained constant throughout, sensitivity to the terminal-link schedules (b in Equation 2) appears to have increased with increasing SIL duration, although the size of this increase was quite small.

The dissimilar effect on response- and time-allocation measures of bias of increasing SIL duration was also evident when the two bias values were compared for each subject at each SIL. For the two shorter SIL values (5 s and 10 s) the response-allocation biases were greater than the corresponding time-allocation values for 11 of the 12 comparisons. However, for the three longer SIL durations the response-allocation biases were less than the corresponding time-allocation values for 15 of the 18 comparisons.

The mean response rates during the terminal-link schedules across subjects were calculated for each condition. Informal observation showed that the subjects responded at a high rate during the terminal links, so the arranged time values (VI 6 s and VI 12 s) could be used for this calculation with some confi-

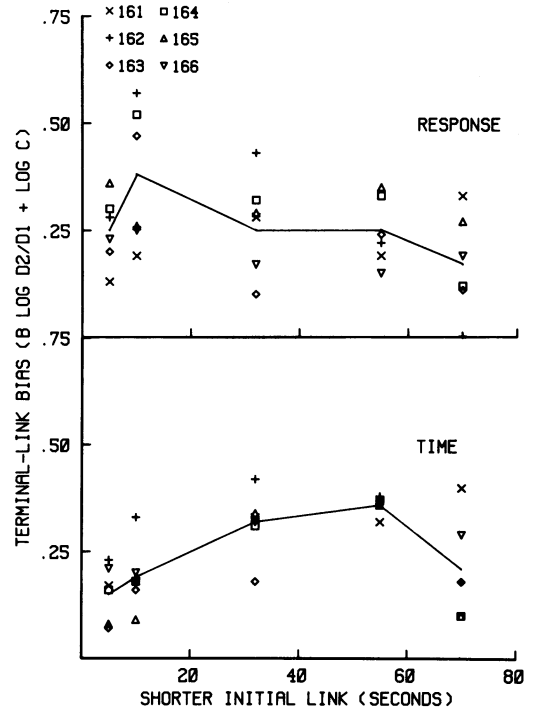

Fig. 4. Bias ($b \log D_{2t}/D_{1t} + \log c$ in Equation 2) plotted for each subject at each shorter initial-link duration. Response-allocation data are shown in the top panel and time-allocation data in the bottom panel. The mean bias values across subjects at each shorter initial-link duration are joined.

dence. For each condition the mean response rate during the VI 6-s terminal link was higher than during the VI 12-s terminal link. The mean response rates during the VI 12-s terminal link ranged from 83 per minute (Condition 11) to 117 per minute (Condition 3); the mean across subjects and conditions was 99 per minute. For the VI 6-s terminal link, the mean response rate ranged from 113 per minute (Conditions 10 and 24) to 199 per minute (Condition 3); the mean rate across subjects and conditions was 146 per minute. No systematic changes in response rates were found across SIL durations or across the conditions within a particular SIL set of conditions for either of the two terminal links.

DISCUSSION

Concurrent-chain experiments often differ from one another in terms of the general procedure used. Many studies employ independent initial-link schedules, most have no COD,

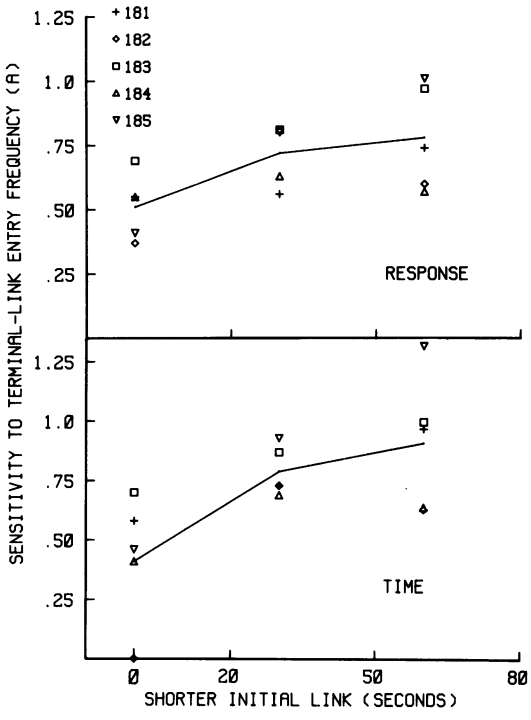

Fig. 5. Sensitivity to the terminal-link entry ratio (a in Equation 2) plotted for each subject at each shorter initial-link duration from the data of Davison (1983). Response-allocation data are shown in the top panel and time-allocation data in the bottom panel. The mean sensitivity values across subjects at each shorter initial-link duration are joined.

and the manner in which the terminal links are arranged can differ (e.g., Gentry & Marr, 1980; Moore, 1982). The proliferation of models describing concurrent-chain performance (e.g., Davison, 1987; Davison & Temple, 1973; Fantino, 1969; Fantino & Davison, 1983; Killeen, 1982) may be attributable, in part, to these differences in procedure. The findings of Davison (1987) are consistent with this suggestion. He tested the predictions of several models of concurrent-chain performance using the data from a number of previously reported experiments. He found that all models described the data from some experiments well, that the data from some experiments fit all the models, and that the data from other experiments fit none of the models.

The procedure used in the present experiment and by Davison (1983) provided orderly results that are consistent across two concurrent-chain experiments employing different terminal-link schedules; that is, response-in-

dependent, fixed-duration terminal links in Davison (1983) and response-dependent, variable-duration terminal links in the present experiment. Furthermore, the order obtained using the present procedure readily lent itself to analysis by the generalized matching law, thereby enabling a parsimonious treatment of choice in both concurrent schedules and concurrent-chain schedules. This parsimony may arise from the constraints that the present procedure placed on performance (a 3-s COD and dependent scheduling), which were used because these are the constraints widely employed in contemporary concurrent-schedule research.

The results from Davison (1983) suggested that the effects of changes in either the initial-link or the terminal-link absolute durations had no effect on the sensitivity of behavior to initial-link contingencies (a in Equation 2), but changed the sensitivity to the terminal-link contingencies (b in Equation 2). Therefore, by measuring the extent to which changes in initial-link and terminal-link duration affect the "value" of a terminal link entry, developing a model of concurrent-chain performance would seem straightforward. However, the results of the present experiment suggest that the situation is far more complex. Not only does the initial-link duration affect sensitivity to terminal-link contingencies (Davison, 1983), but the present experiment showed that it also affects sensitivity to initial-link contingencies. Although not statistically significant, the data from Davison (1983, Experiment 2) show the same pattern as those obtained in the present experiment. For comparison, these a values are shown in Figure 5.

Although it is clear that a values changed with increasing SIL, it is less clear whether this was a function solely of the initial-link duration or of some relation between the initial-link and terminal-link durations. The data from Davison (1983) supported the former hypothesis because the a values in Experiment 1 showed no systematic changes across a variety of different terminal-link schedules. However, only one SIL schedule (30 s) was used in Experiment 1, so some caution is probably necessary. The latter hypothesis is attractive because it explains the consistency of a values obtained from concurrent-schedule experiments (Baum, 1979) compared to the changing a values demonstrated in the present concur-

rent-chain experiment; that is, with 0-s terminal links (i.e., concurrent schedules) there is no terminal-link/initial-link interaction and hence no change in sensitivity with changes in initial-link duration.

It is interesting to note that the time-allocation a values tended to be lower than the response-allocation a values at the shortest SIL duration (5 s). Possibly, with initial links of this duration, the 3-s COD may have caused time-allocation measures of choice to be less extreme than their corresponding response-allocation measures.

The effect of increasing SIL duration on terminal-link bias ($b \log D_{2i}/D_{1i} + \log c$ in Equation 2) in the present experiment was unexpected. The increase in bias with increasing SIL shown in the time-allocation data of the present experiment was very small, whereas the response-allocation measures of terminal-link bias showed no effect of increasing SIL. The results of Experiment 2 of Davison (1983) clearly showed a decrease in bias with increasing SIL for both the time- and response-allocation data (Figure 6).

This difference between the results of the two experiments may be attributed to one of two possible sources. First, SIL duration may have different effects on VI terminal links than on FD terminal links. However, considering the similarity between the results of the two different studies in all other respects, this does not seem likely. A more likely explanation is that the terminal links in the present experiment (VI 6 s and VI 12 s) were not long enough to show the effect of increasing SIL duration obtained by Davison (1983) (FD 15-s and FD 30-s terminal links); in other words, there may have been a floor effect in the data from the present study. For example, the bias values in Figure 5 from Davison (1983) showed little change from the SIL 30-s to the SIL 60-s durations.

To summarize, the results from this experiment and those of Davison (1983) suggest that if the initial links of a concurrent-chain schedule are arranged with the constraints typically found in concurrent schedules, the data are orderly and are readily described by the form of the generalized matching law shown in Equation 2. There were two major differences between the results from the present experiment and those obtained by Davison (1983). First, in the present experiment, increasing the

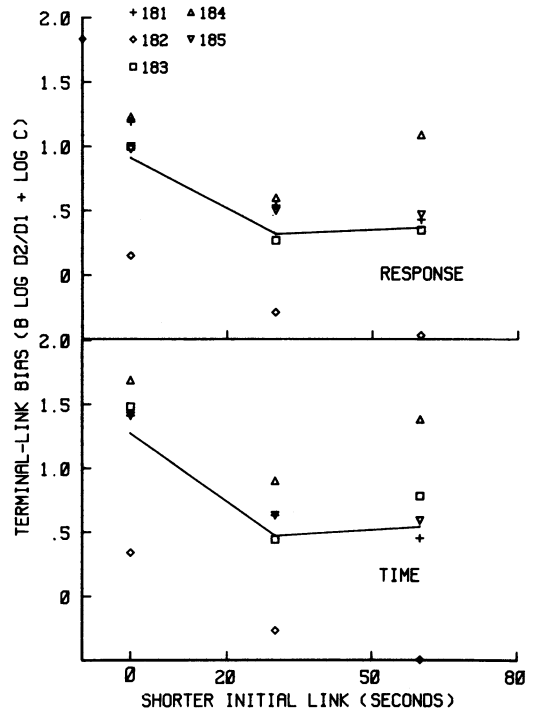

Fig. 6. Bias ($b \log D_{2i}/D_{1i} + \log c$ in Equation 2) plotted for each subject at each shorter initial-link duration from the data of Davison (1983). Response-allocation data are shown in the top panel and time-allocation data in the bottom panel. The mean bias values across subjects at each shorter initial-link duration are joined.

duration of the shorter initial-link schedule led to significant increases in the sensitivity (a in Equation 2) to the consequences of initial-link responding; that is, to the obtained terminal-link entry ratio. This complicates the conclusions of Davison (1983), where initial-link and terminal-link durations appeared only to affect sensitivity to the terminal-link schedules. Second, in the present experiment, sensitivity to the terminal-link schedules (b in Equation 2) appeared to change little across the SIL durations. However, this was probably due to the rather short duration of the terminal links relative to the initial-link durations.

REFERENCES

- Baum, W. M. (1979). Matching, undermatching, and overmatching in studies of choice. *Journal of the Experimental Analysis of Behavior*, *32*, 269-281.
- Baum, W. M., & Rachlin, H. C. (1969). Choice as time allocation. *Journal of the Experimental Analysis of Behavior*, *12*, 861-874.

- Davison, M. (1983). Bias and sensitivity to reinforcement in a concurrent-chain schedule. *Journal of the Experimental Analysis of Behavior*, **40**, 15-34.
- Davison, M. (1987). The analysis of concurrent-chain performance. In M. L. Commons, J. E. Mazur, J. A. Nevin, & H. Rachlin (Eds.), *Quantitative analyses of behavior: Vol. 5. The effect of delay and of intervening events on reinforcement value* (pp. 225-241). Hillsdale, NJ: Erlbaum.
- Davison, M., & Hogsden, I. (1984). Concurrent variable-interval schedule performance: Fixed versus mixed reinforcer durations. *Journal of the Experimental Analysis of Behavior*, **41**, 169-182.
- Davison, M. C., & Temple, W. (1973). Preference for fixed-interval schedules: An alternative model. *Journal of the Experimental Analysis of Behavior*, **20**, 393-403.
- de Villiers, P. (1977). Choice in concurrent schedules and a quantitative formulation of the law of effect. In W. K. Honig & J. E. R. Staddon (Eds.), *Handbook of operant behavior* (pp. 233-287). Englewood Cliffs, NJ: Prentice-Hall.
- Duncan, B., & Fantino, E. (1970). Choice for periodic schedules of reinforcement. *Journal of the Experimental Analysis of Behavior*, **14**, 73-86.
- Fantino, E. (1969). Choice and rate of reinforcement. *Journal of the Experimental Analysis of Behavior*, **12**, 723-730.
- Fantino, E., & Davison, M. (1983). Choice: Some quantitative relations. *Journal of the Experimental Analysis of Behavior*, **40**, 1-13.
- Fantino, E., & Royalty, P. (1987). A molecular analysis of the choice on concurrent-chains schedules. *Journal of the Experimental Analysis of Behavior*, **48**, 145-159.
- Ferguson, G. A. (1965). *Nonparametric trend analysis*. Montreal: McGill University Press.
- Gentry, G. D., & Marr, M. J. (1980). Choice and reinforcement delay. *Journal of the Experimental Analysis of Behavior*, **33**, 27-37.
- Hollard, V., & Davison, M. C. (1971). Preference for qualitatively different reinforcers. *Journal of the Experimental Analysis of Behavior*, **16**, 375-380.
- Hunter, I., & Davison, M. (1982). Independence of response force and reinforcement rate on concurrent variable-interval schedule performance. *Journal of the Experimental Analysis of Behavior*, **37**, 183-197.
- Killeen, P. (1968). Response rate as a factor in choice. *Psychonomic Science*, **12**, 34.
- Killeen, P. R. (1982). Incentive theory: II. Models for choice. *Journal of the Experimental Analysis of Behavior*, **38**, 217-232.
- Miller, J. T., Saunders, S. S., & Bourland, G. (1980). The role of stimulus disparity in concurrently available reinforcement schedules. *Animal Learning & Behavior*, **8**, 635-641.
- Moore, J. (1982). Choice and multiple reinforcers. *Journal of the Experimental Analysis of Behavior*, **37**, 115-122.
- Neuringer, A. J. (1969). Delayed reinforcement versus reinforcement after a fixed interval. *Journal of the Experimental Analysis of Behavior*, **12**, 375-383.
- Siegel, S. (1956). *Nonparametric statistics for the behavioral sciences*. New York: McGraw-Hill.
- Snyderman, M. (1983). Delay and amount of reward in a concurrent chain. *Journal of the Experimental Analysis of Behavior*, **39**, 437-447.
- Squires, N., & Fantino, E. (1971). A model for choice in simple concurrent and concurrent-chains schedules. *Journal of the Experimental Analysis of Behavior*, **15**, 27-38.
- Stubbs, D. A., & Pliskoff, S. S. (1969). Concurrent responding with fixed relative rate of reinforcement. *Journal of the Experimental Analysis of Behavior*, **12**, 887-895.
- Williams, B. A., & Fantino, E. (1978). Effects on choice of reinforcement delay and conditioned reinforcement. *Journal of the Experimental Analysis of Behavior*, **29**, 77-86.

Received May 2, 1986

Final acceptance January 9, 1988

APPENDIX

The number of responses emitted during, and time spent in, each initial link, and the number of responses emitted and entries into each terminal link, summed over the last five sessions of each condition for each subject.

Condition	Initial link				Terminal link			
	Responses		Time		Responses		Entries	
	Left	Right	Left	Right	Left	Right	Left	Right
Bird 161								
1	3,580	2,181	7,963	1,773	1,360	2,010	102	94
2	2,634	1,386	3,595	1,260	1,429	2,506	94	106
3	5,086	605	6,489	542	2,641	1,144	156	44
4	1,217	4,185	994	5,511	270	3,330	21	175
5	5,497	772	5,534	612	2,491	611	169	31
6	1,837	4,366	1,687	4,498	630	3,684	40	160
7	1,421	826	1,734	1,048	1,229	2,508	91	109
8	833	196	1,546	365	1,549	983	159	41
9	255	580	399	1,585	229	3,343	19	181
10	525	166	1,395	248	1,629	400	178	22
11	514	875	773	1,491	372	2,380	31	169
12	8,266	1,514	9,138	1,224	1,992	635	162	37
13	3,969	2,237	4,435	2,108	1,259	1,364	104	96
14	1,919	6,324	1,905	6,557	170	2,478	18	132
15	7,008	672	8,496	622	1,818	270	134	16
16	2,836	8,684	2,746	7,604	416	2,836	34	166
17	657	860	880	1,083	376	2,749	36	164
18	1,113	378	1,438	489	1,469	823	151	48
19	8,308	865	8,877	765	1,444	524	119	31
20	3,275	6,229	3,762	6,817	192	1,971	13	127
21	2,068	6,258	2,445	7,010	238	2,213	21	128
22	809	509	1,149	920	1,009	1,531	103	97
23	195	674	455	1,140	261	2,993	21	179
24	622	169	1,237	244	1,908	251	181	19
25	5,343	1,974	4,716	1,972	891	1,155	76	74
26	6,018	1,044	10,219	1,011	1,643	255	127	18
Bird 162								
1	4,468	1,493	8,658	2,016	2,271	1,874	57	71
2	11,112	1,209	5,639	1,199	3,915	2,808	92	108
3	10,108	938	6,022	625	6,191	1,177	158	42
4	2,061	8,027	1,736	4,637	712	4,730	21	179
5	9,387	1,283	6,403	680	5,367	879	171	29
6	3,189	6,781	2,441	4,842	1,243	4,037	44	156
7	3,081	708	1,475	645	2,693	2,125	111	89
8	2,309	309	1,130	259	3,356	732	167	33
9	1,721	1,618	796	1,478	572	4,379	20	180
10	2,392	211	1,241	174	3,237	601	174	26
11	2,788	1,428	1,611	1,330	1,096	3,715	38	162
12	11,495	4,970	8,795	2,477	3,663	1,173	141	44
13	7,255	3,632	4,647	2,195	2,181	2,746	93	107
14	2,528	10,276	2,653	6,738	215	3,275	11	139
15	10,143	1,502	7,689	711	3,530	378	138	12
16	6,862	9,815	5,336	5,248	1,120	3,830	45	149
17	805	1,911	517	1,001	644	4,932	35	165
18	1,947	357	1,016	205	3,189	923	167	33
19	12,190	4,104	8,515	1,722	3,701	883	118	31
20	3,336	15,031	2,400	7,202	558	3,495	20	127
21	4,183	11,923	2,995	6,067	762	3,171	30	118
22	1,616	1,025	1,207	702	1,827	2,723	99	101
23	754	1,541	452	1,005	379	5,125	19	181
24	3,024	180	938	114	3,117	514	183	17
25	6,937	7,158	3,666	2,851	1,651	1,770	75	75
26	11,281	2,413	10,147	1,004	3,783	391	123	13

APPENDIX (Continued)

Condition	Initial link				Terminal link			
	Responses		Time		Responses		Entries	
	Left	Right	Left	Right	Left	Right	Left	Right
Bird 163								
1	3,360	3,392	5,241	2,298	1,744	2,863	95	105
2	2,794	1,764	3,306	1,766	1,468	3,468	88	112
3	4,957	1,655	5,470	981	3,314	1,554	157	43
4	1,185	5,532	828	5,428	427	4,337	21	179
5	4,816	486	6,520	373	4,723	583	183	17
6	1,890	5,827	1,307	4,684	780	4,149	43	157
7	3,268	566	1,696	775	1,949	2,272	106	94
8	1,837	261	1,194	274	2,473	735	171	29
9	640	761	517	1,640	480	3,006	25	175
10	1,561	216	1,256	259	2,695	797	171	29
11	717	686	640	1,321	543	2,841	36	164
12	7,052	1,287	10,046	1,033	2,614	707	139	27
13	6,542	2,688	5,155	2,478	1,516	2,041	99	101
14	2,400	5,997	2,862	7,350	292	2,898	15	130
15	5,535	513	9,006	419	2,535	259	137	13
16	4,889	7,776	3,835	7,115	724	3,190	39	161
17	789	1,635	585	1,431	581	2,911	44	156
18	2,824	505	1,568	432	2,020	933	161	39
19	6,215	889	10,564	801	1,868	552	106	24
20	2,325	10,421	2,404	7,568	287	3,033	15	132
21	4,334	8,419	2,582	6,481	401	2,562	27	123
22	2,044	1,229	1,089	1,010	1,591	2,289	102	98
23	588	1,290	300	1,110	321	4,107	19	181
24	1,691	273	1,261	202	2,083	505	185	17
25	3,238	3,853	2,717	3,592	1,154	1,882	76	74
26	9,169	2,172	9,221	1,820	1,517	566	130	20
Bird 164								
1	5,064	1,529	7,215	1,616	1,323	1,685	98	96
2	4,024	1,188	5,226	961	1,466	1,440	111	89
3	4,927	1,157	6,166	637	2,197	844	154	46
4	658	4,267	478	6,014	260	2,927	15	185
5	5,147	467	7,293	375	2,571	335	177	23
6	1,483	4,132	1,085	4,658	537	2,435	38	162
7	1,850	329	1,979	737	1,304	1,139	108	80
8	1,410	107	1,331	298	1,575	484	169	31
9	445	559	500	1,538	284	2,891	23	177
10	770	89	1,236	224	1,439	282	179	21
11	932	687	948	1,471	535	2,220	45	155
12	6,383	1,069	10,051	1,433	1,337	595	151	47
13	5,442	1,666	6,323	1,650	1,159	1,516	97	103
14	985	7,957	721	7,599	168	2,427	13	137
15	7,490	579	8,749	467	1,505	343	129	21
16	2,487	7,128	2,054	8,691	542	2,486	36	164
17	732	828	659	1,554	245	1,836	33	167
18	1,237	213	1,215	228	1,715	437	162	38
19	9,850	1,162	8,720	760	1,395	400	118	32
20	590	8,229	636	8,926	132	1,804	13	137
21	2,071	6,455	1,642	7,303	336	1,594	34	116
22	1,201	652	1,152	821	944	1,569	94	106
23	401	830	283	1,049	165	2,851	16	184
24	1,079	191	1,116	206	1,606	176	182	19
25	4,464	2,861	3,652	3,199	743	1,118	77	73
26	10,605	802	10,018	591	1,790	311	136	14

APPENDIX (Continued)

Condition	Initial link				Terminal link			
	Responses		Time		Responses		Entries	
	Left	Right	Left	Right	Left	Right	Left	Right
Bird 165								
1	3,741	2,277	6,277	2,031	937	1,573	98	102
2	4,044	953	4,470	722	1,180	1,540	114	86
3	4,557	427	5,727	313	1,312	539	164	36
4	1,616	5,770	985	5,366	158	3,128	23	177
5	5,908	224	6,132	162	2,101	203	187	13
6	1,529	5,926	1,124	5,045	580	2,877	40	160
7	1,745	926	1,219	923	1,231	1,585	104	96
8	1,540	259	1,259	288	1,784	614	167	33
9	353	846	343	1,333	212	3,188	19	181
10	928	88	1,174	137	1,646	233	188	12
11	493	705	489	1,328	364	3,219	38	162
12	7,746	785	9,803	701	1,565	770	147	37
13	6,601	2,067	6,300	1,773	1,204	1,755	106	94
14	1,955	4,916	1,564	6,905	225	1,423	17	133
15	8,293	373	9,295	365	1,527	274	137	13
16	2,568	6,007	2,244	8,369	524	2,309	39	154
17	445	1,088	295	1,020	582	2,496	39	161
18	2,220	260	1,081	323	2,310	714	159	41
19	10,413	1,519	7,738	1,751	1,883	516	121	29
20	813	6,767	546	10,010	174	1,996	12	130
21	2,547	6,069	1,787	7,464	375	1,870	31	119
22	1,647	480	1,107	769	1,299	1,730	101	99
23	296	672	305	981	167	2,754	13	187
24	1,630	168	1,064	221	2,174	390	183	17
25	5,745	2,123	4,606	1,847	964	1,311	76	74
26	8,654	667	10,545	788	1,766	257	133	14
Bird 166								
1	3,478	2,641	5,505	5,241	1,292	1,437	103	78
2	2,575	1,234	4,038	1,437	1,123	1,008	100	100
3	3,513	616	6,324	460	2,598	431	168	32
4	953	4,810	914	5,536	210	4,521	17	183
5	5,545	690	6,426	398	1,469	457	175	25
6	1,835	5,502	1,417	4,366	297	3,286	41	159
7	1,611	1,030	1,366	815	648	1,724	96	104
8	1,522	424	1,277	325	829	586	161	39
9	362	839	412	1,344	196	1,855	24	176
10	1,353	202	1,221	181	1,358	307	177	23
11	1,005	863	1,034	1,257	329	1,701	44	156
12	8,134	1,262	10,174	725	1,041	616	160	38
13	4,781	2,393	5,993	1,840	874	1,643	97	103
14	1,915	8,865	1,878	6,724	101	1,430	11	139
15	7,765	1,110	8,377	580	1,277	270	133	17
16	3,031	11,061	4,132	6,439	333	1,775	45	157
17	671	1,473	499	959	329	3,317	36	164
18	1,679	429	1,164	281	1,091	896	153	47
19	8,975	1,381	8,735	999	980	563	121	29
20	2,001	9,876	1,742	7,773	100	2,049	13	137
21	2,797	8,230	2,430	6,483	256	1,607	31	119
22	1,463	840	1,027	623	600	2,098	101	99
23	339	1,153	305	1,047	124	3,331	18	182
24	1,606	147	1,060	145	1,481	552	179	21
25	6,439	3,042	5,016	1,793	747	1,376	79	71
26	9,580	1,080	9,902	710	1,265	280	143	16