

THE EFFECT OF PITUITARY STALK SECTION
ON THE ADRENOCORTICAL RESPONSE TO
STRESS IN THE RABBIT

BY C. FORTIER,* G. W. HARRIS AND I. R. McDONALD†

*From the Department of Neuroendocrinology, Institute of Psychiatry,
Maudsley Hospital, London*

(Received 10 December 1956)

It is now generally agreed that the hypothalamus exerts a controlling influence over the release of adrenocorticotrophic hormone (ACTH) from the anterior pituitary gland. Electrical stimulation of various hypothalamic regions have been found to result in a lymphopenia or eosinopenia (de Groot & Harris, 1950; Hume & Wittenstein, 1950; Hume, 1953; Porter, 1953, 1954) in the rabbit, dog, cat and monkey. Also, hypothalamic lesions have been found to abolish the adrenocorticotrophic response to stressful or noxious stimuli (de Groot & Harris, 1950; Hume & Wittenstein, 1950; Hume, 1953; McCann, 1953; Laqueur, McCann, Schreiner, Rosemberg, Rioch & Anderson, 1953; Porter, 1953, 1954) in the rabbit, dog, rat, cat and monkey. However, it is uncertain whether the hypothalamus and its connexions with the adeno-hypophysis are necessary for the mediation of the ACTH response to all types of stressful stimuli. Several groups of workers (Cheng, Sayers, Goodman & Swinyard, 1949*b*; McDermott, Fry, Brobeck & Long, 1950*b*; Fortier, 1951) have found that intra-ocular pituitary transplants in the hypophysectomized rat may be stimulated to release ACTH by unilateral adrenalectomy and by injection of histamine or adrenaline. Fortier (1951) found that such rats did not show an ACTH response after exposure to loud sounds or forced immobilization, and on these grounds divided stresses into two groups: (1) neurotropic stresses (such as loud sounds and forced immobilization), those that elicit ACTH discharge by an action solely through the central nervous system; and (2) systemic stress (such as administration of adrenaline), which may act by producing chemical or metabolic changes in the general blood stream as well as by

* Present address: Bluebird Neurological Research Laboratories, Methodist Hospital, Texas Medical Center, Houston, Texas, U.S.A.

† Present address: Physiology Department, University of Melbourne, Carlton N3, Victoria, Australia.

an action through the nervous system. The anatomical pathway by which the hypothalamus influences anterior pituitary secretion of ACTH appears to be the hypophysial portal vessels, which pass from the tuber cinereum down the pituitary stalk to the anterior lobe. Electrolytic lesions placed in these vessels in the zona tuberalis of the rabbit's pituitary were found to abolish the lymphopenic response to emotional stress (de Groot & Harris, 1950); the return of the lymphopenic response to stress in the pituitary stalk-sectioned mouse was found to be correlated with regeneration of the portal vessels between the stalk ends (de Groot, 1952); and the maintenance of a normal adrenal cortex in the hypophysectomized rat bearing a pituitary transplant was observed to be dependent on the vascularization of the grafted tissue by the portal vessels (Harris & Jacobsohn, 1952). Recent studies made with the electron-microscope show *no* nerve fibres in relation to parenchymal cells within the confines of the pars distalis of the pituitary (M. G. Farquhar & J. F. Rinehart, personal communication; S. L. Palay, personal communication); such a finding is compatible with the above thesis. The factors controlling anterior pituitary activity have recently been reviewed (Harris, 1955).

In order to define further the control exerted by the hypothalamus over pituitary-adrenal function, and the mechanism whereby this control is exerted, a study has been made of the effect, on the adrenocorticotrophic response to different stimuli, of dividing the pituitary stalk in the rabbit. The stimuli used consisted of procedures calculated to produce (1) predominantly nervous or emotional excitation without physical damage (restraint, exposure to cold), or (2) tissue trauma or metabolic disturbances (laparotomy, injection of adrenaline). A fall in blood lymphocytes at the third hour after the beginning of the stressful procedure was taken as a criterion of adrenal cortical activation. As a further test of the adrenocorticotrophic response to trauma, the adrenal ascorbic acid concentration of the right adrenal gland was compared with that of the left gland which had been surgically removed one and a half hours previously.

METHODS

Adult female rabbits (mainly chinchilla), 2.0–3.5 kg body weight, were used. For 1–2 weeks before the initiation of the experiment and until its completion the animals were kept at a constant room temperature of 27–28° C and fed on rabbit pellets (M.R.C. diet 18, supplied by A. C. Taylor Ltd.) and tap water, *ad libitum*. The 104 rabbits included in this study fall into the following groups—37 non-operated controls, 25 hypophysectomized, 13 pituitary stalk-sectioned (simply) and 29 pituitary stalk-sectioned with a plate placed between the cut ends of the stalk. In the case of the operated animals, experiments were not started until 2–3 weeks from the operation or until the body weight had become stabilized. The successive tests of adrenal cortical activity were carried out in each animal at two-weekly or longer intervals. Tests of thyroid function, the results of which are the subject of a separate paper (Brown-Grant, Harris & Reichlin, 1957), were interpolated.

Surgical procedures

Hypophysectomy was performed by the parapharyngeal method of Jacobsohn & Westman (1940). Basal anaesthesia was induced with Nembutal (pentobarbitone sodium, Abbott

Laboratories, 0.5-0.7 ml/kg body wt.), the trachea was intubated with a number 15 French gauge rubber catheter and anaesthesia deepened as required with intratracheal ether. Intubation of the trachea obviated the need to perform tracheotomy when the pharynx was retracted. A head holder mounted on a large ball and socket joint was used for immobilizing and easily orientating the head (Text-figs. 1, 2).

Pituitary stalk section. The frontotemporal approach to the pituitary stalk was used (Westman & Jacobsohn, 1940; Jacobsohn, 1954). This method has the disadvantage, compared with the temporal route of Harris & Popa (1938) that a larger area of the skull vault is removed, but possesses the advantage that the jaw joint is left intact. Since this operation has not been described in detail, the procedure used in the present study, slightly modified from that of Jacobsohn, will be briefly presented.

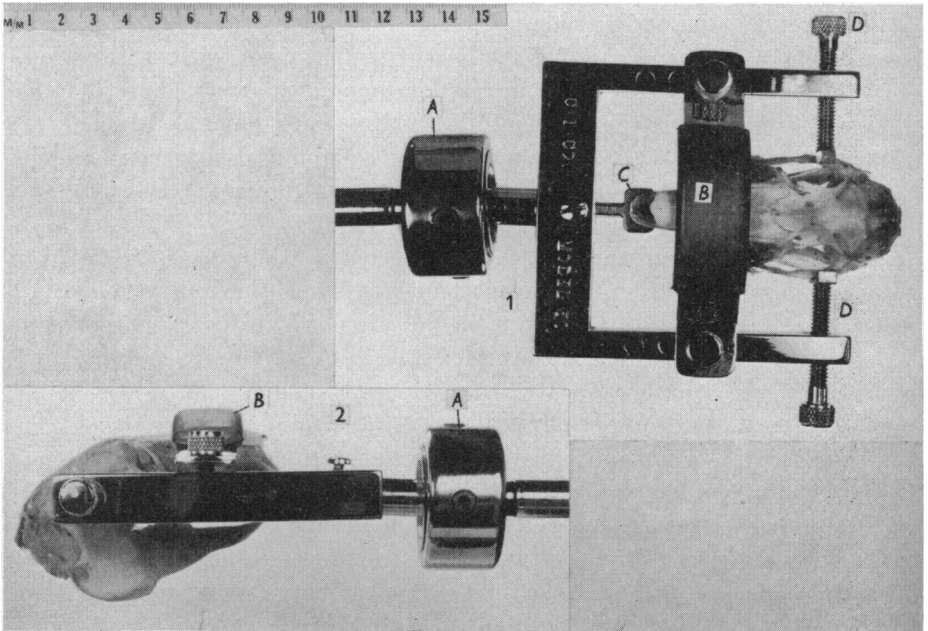

Text-figs. 1, 2. Head holder: Text-fig. 1, view from above; Text-fig. 2, lateral view. The essential features of the holder are that it leaves the vault and the base of the skull free for any manipulations (as involved in the operations of pituitary stalk section and hypophysectomy), and that the head can be placed easily and quickly in any position in the three planes of space by means of the ball and socket joint (A). The nose-piece (B) and the incisor-tooth socket (C) can be adjusted for rabbits of different size. The fixation bars (D) grip the posterior end of the zygomatic arches.

Anaesthesia is the same as for hypophysectomy. After mounting the head firmly in the holder the skin of the scalp is incised in the coronal plane from the posterior end of the right zygomatic arch to the mid point of the left temporal crest (Text-fig. 3). The bones of the vault of the skull are then exposed bilaterally from the occipital crest to the nasal bones in the antero-posterior plane and between the temporal crests and orbits in the transverse plane. On the left side the temporal crest is cleared of muscle and fascia. On the right side the lower posterior border of the temporalis muscle is carefully defined, and separated from the post-glenoid venous sinus, and the

muscle cut in the vertical plane. Loose sutures through the two ends of the muscle form convenient retractors, allowing the bone of the temporal fossa to be cleaned with cotton-wool pledgets, thus exposing the attachment of the zygomatic arch to the side of the skull. The bones of the vault of the skull are drilled through to the dura with an electric dental drill (number 10) along a line as indicated in Text-fig. 4. The loosened skull vault is held with large forceps at the anterior end, carefully separated from the underlying dura, and removed. In most cases this can be accomplished without damage to the dura, though in older animals in which the dura is more tightly attached to the cranial sutures tears are apt to occur. The dura is picked up with fine watchmakers' steel forceps and incised in a longitudinal plane on either side of the superior sagittal sinus. At this stage care is taken to avoid damage to the superior cerebral veins draining into the sinus. Two transverse cuts in the dura now allow four dural flaps to be turned over the bone margins to expose the upper surface of both cerebral hemispheres with the superior sagittal sinus still remaining *in situ* (Text-fig. 5). The animal's head is inverted and positioned about 1 ft above the operating

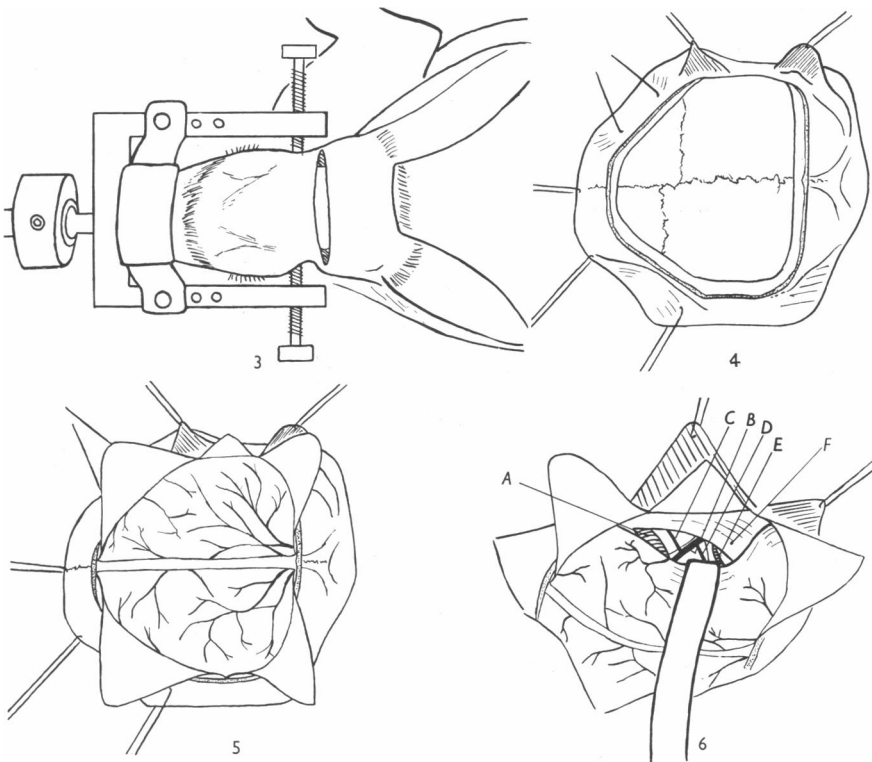

Text-figs. 3-6. To illustrate the successive stages in the operative procedure used to divide the pituitary stalk in the rabbit. Text-fig. 3 shows the positioning of the head in the clamp and the skin incision. Text-fig. 4 shows the exposed skull vault and the area of bone removed by drilling; note that on the right side the drill line extends down towards the zygomatic arch. Text-fig. 5 illustrates the exposed cerebral hemispheres after turning back the dural flaps; the superior sagittal sinus and the superior cerebral veins draining into it are left intact. Text-fig. 6 shows the view obtained, with the animal's head in an inverted position after retraction of the temporal lobe of the brain. *A*, optic nerve; *B*, internal carotid artery with its orbital branch, *C*, and the posterior communicating artery, *D*; *E*, oculomotor nerve; *F*, tentorium cerebelli.

table. The further stages are performed in a darkened room with head-lamp illumination. Retraction of the temporal lobe is carried out with a curved copper retractor and, aided by gravity, the right temporal lobe is slowly eased out of the skull and towards the opposite side. The previous removal of the left part of the cranial vault makes this latter step possible. The oculomotor and optic nerves are the first structures in the pituitary region to come into view and with slightly more retraction the internal carotid artery is seen. At this point the retractor is appropriately weighted and allowed to hang from the brain, thus freeing both hands of the operator. When full retraction is obtained, the field as depicted in Text-fig. 6 is seen. The oculomotor nerve, the upper surface of the sella turcica, the internal carotid artery with its orbital and two terminal branches and the optic nerve are easily visible. The pituitary stalk runs vertically (as related to the rabbit) on the deep aspect of the internal carotid artery and is not clearly visible until it is picked up on a curved hook (inserted deep to the carotid) and pulled into view. After tearing the stalk, bleeding is negligible. Following this procedure pledgets of cotton-wool are inserted anterior to the carotid artery, pushed backwards between the two internal carotid arteries and pulled out posteriorly, thus ensuring that all the stalk has been severed. When this has been done the tuber cinereum falls away from the sella turcica and a larger area of the upper surface of the pituitary comes into view, including the small haemorrhagic point in the diaphragma sellae through which the stalk originally passed. It is important to note that with this technique the stalk is cut at the plane of the diaphragma sellae. In one group (13 rabbits) a waxed-paper plate was inserted beneath the optic nerves and pushed posteriorly between the two internal carotid arteries so that it was finally situated beneath the hypothalamus and above the pituitary gland. This plate was then removed to allow any regeneration of the portal vessels to occur. In the other groups several procedures were adopted in an attempt to prevent regeneration of the portal vessels across the site of stalk section. First (14 rabbits), a waxed-paper plate was inserted as above and left *in situ*. Secondly (6 rabbits), attempts were made to destroy the median eminence and primary plexus of the portal vessels by means of a d.c. current (usually 3 mA for 1 min) applied to the tuber cinereum with a curved platinum electrode; after this procedure the stalk was cut and a plate inserted. Thirdly (9 rabbits) the right internal carotid artery was tied in the neck and one week later this artery was exposed intracranially, ligated and cut, the pituitary stalk cut, one or both oculomotor nerves removed, a piece of warm paraffin wax pressed on to the diaphragma sellae to fill in the depression between the two anterior clinoid processes and a large waxed-paper plate inserted under the hypothalamus and secured by pressing between the borders of the tentorium cerebelli and the clinoid processes.

After these measures the head of the animal was restored to the upright position at operating table level and the brain allowed to fall back into position. Repair of the cranial defect was performed with strips of fine polythene film (0.002 in. thickness) which were retained in position by loosely suturing the dural flaps over them. Eversion sutures in the skin completed the operation. Three doses of Seclomycin (Glaxo Laboratories Ltd, each containing penicillin 100,000 i.u. and streptomycin 0.15 g) were administered subcutaneously during the next 48 hr. Approximately 50% of the animals recovered from the operation and formed suitable preparations for subsequent experiments.

Stimuli

(1a) *Restraint*. The animals were placed for 3 hr in a restraining clamp as described by Harris (1948b).

(1b) *Cold*. The animals were enclosed in a darkened, fan-ventilated box, and exposed to a continuous stream of cold air (2–3° C) for a period of 3 hr.

(2c) *Adrenaline*. A subcutaneous injection of 0.5 mg of adrenaline in the form of the salt of mucic acid (hyperduric adrenaline, Allen and Hanburys Ltd.) was given in the neck region.

(2d) *Laparotomy*. A mid-line abdominal incision, extending 10 cm caudally from a point just below the xiphisternum, was made under ether anaesthesia. The abdominal viscera moistened with saline were exposed to air for a period of 15 min, at the end of which time the incision was closed in layers with continuous and interrupted sutures. Three doses of Seclomycin were administered subcutaneously during the next 48 hr.

Indices of adrenal cortical activity

Blood lymphocytes. Lymphopenia has been shown to be a valid index for the release of adrenocorticotrophic hormone from the anterior pituitary in a variety of experimental animals. This has been confirmed in the rabbit by Colfer, de Groot & Harris (1950). Samples of freely flowing blood were collected from the marginal vein of the ear (care being taken not to disturb the animal unduly) immediately before and 3 hr after the initiation of the stimulus. The total white cell count was made using the improved Neubauer form of haemocytometer, diluting the blood 20 times with 1% hydrochloric acid or 1% acetic acid tinged with gentian violet, and counting the number of cells contained in 0.4 mm³ of diluent. The mean count of three separate dilutions was determined. The differential count was made by counting 100 cells (stained with Leishman's stain)

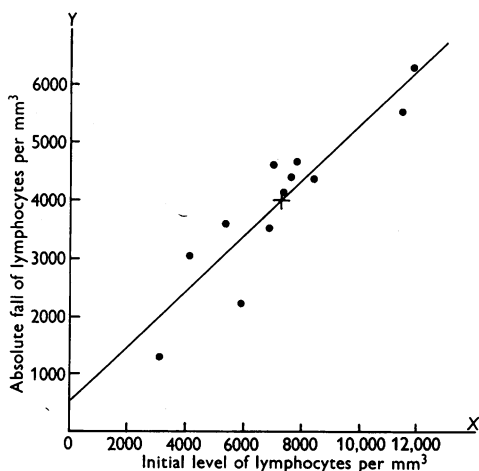

Text-fig. 7. To show the relationship between the initial count and the absolute fall of blood lymphocytes following injection of adrenaline in normal rabbits.

$$r = 0.91; Y = 0.48x + 520; Sy = \sigma_y \sqrt{1 - r^2} = \pm 539.$$

on each of three blood smears. A foot-operated electric counting device was used to record the number of cells. The average total leucocyte count in 12 normal rabbits was found to be $10,249 \pm 309$ (s.e.m.), and the absolute lymphocyte count was 7237 ± 410 . These figures are in close agreement with those of Dougherty & White (1944) and Colfer *et al.* (1950). The result of each test was expressed as the percentage change from the initial level of the absolute lymphocyte count. This form of expression of the results has been found to be valid in the case of the eosinopenic response to adrenal cortical activation in the rat (McDermott, Fry, Brobeck & Long, 1950*a*). Similarly, in the case of the rabbit individual variations in the initial level of blood lymphocytes are compensated by a high degree of correlation between the latter and the absolute fall in response to a given stimulus (Text-fig. 7).

Adrenal ascorbic acid. Since the original work of Sayers, Sayers, Liang & Long (1946), adrenal ascorbic acid depletion has been accepted as a specific indicator of ACTH-induced adrenal cortical activation in the rat. Likewise, we have observed in the rabbit that a depletion of the adrenal ascorbic acid concentration occurs in response to stress (unilateral adrenalectomy). This depletion, absent in the hypophysectomized animal, is reproduced in the latter by the administration of ACTH. In a series of experiments on normal rabbits it was found that there was no significant difference between the ascorbic acid concentration of left and right adrenals, and that the optimum time interval for maximum ascorbic acid depletion after stress was $1\frac{1}{2}$ hr (Text-fig. 8).

Left adrenalectomy was performed under ether anaesthesia. The time taken between commencement of anaesthesia and removal of the gland (using a mid-line abdominal incision) was usually 3–5 min, although occasionally the procedure took up to 7 min. The gland was rapidly dissected free of fat (care being taken not to damage the capsule), weighed on a Stanton analytical balance, transferred to a Pyrex test-tube containing 40 ml. of 4% trichloroacetic acid and a little acid-washed sand, and ground with the flattened tip of a glass rod attached to an electric motor. One and a half hours after the beginning of the anaesthesia the animal was killed by the intravenous injection of 3–4 ml. of veterinary Nembutal. The right adrenal gland was removed immediately and

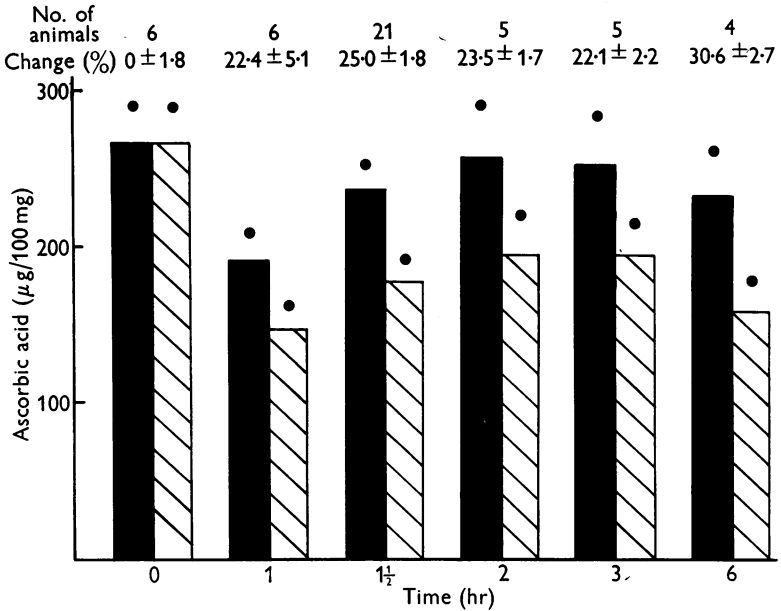

Text-fig. 8. Comparison of adrenal ascorbic acid concentration in the right and left adrenal glands at various time intervals after left adrenalectomy. ■, left gland; ▨, right gland; ●, s.e.m. of group.

treated in the same way as the left. The samples were left during the night in a refrigerator and the ascorbic acid concentration of a trichloroacetic acid filtrate was determined by the method of Roe & Kuether (1943), as adapted to the adrenal by Sayers, Sayers & Woodbury (1948). A Hilger 'Spekker' photometer, with cuvettes of 2 cm light-path, was used to read the colour intensity at 540 m μ . In view of the rather low correlation coefficient between the initial ascorbic acid concentration and the absolute fall (Text-fig. 9), the initial and final ascorbic acid concentration will be presented as well as the difference (in brackets) and the percentage fall.

Histological procedures

Immediately after death the rabbits were injected with 200 ml. 1:3 indian ink (Mandarin Black, Winsor and Newton) through the carotid arteries; the head was then removed, trimmed and fixed in 10% formalin (de Groot & Harris, 1950). After complete fixation all heads were decalcified in a formic acid and sodium formate mixture (Engelbreth-Holm & Plum, 1951) and dehydrated, and a block of tissue containing the hypothalamus, base of skull and pituitary gland was embedded in low viscosity nitrocellulose. Serial sections, 200 μ thick, were cut and stained with haematoxylin and eosin, or eosin alone. These were examined with special reference to pituitary volume in

intact and stalk-sectioned animals, for evidence of portal vessel regeneration in stalk-sectioned controls, and for the presence of pituitary remnants in hypophysectomized animals.

Determination of pituitary volume was performed by the paper-weighing method and forms the subject of a separate communication (Campbell & Harris, 1957).

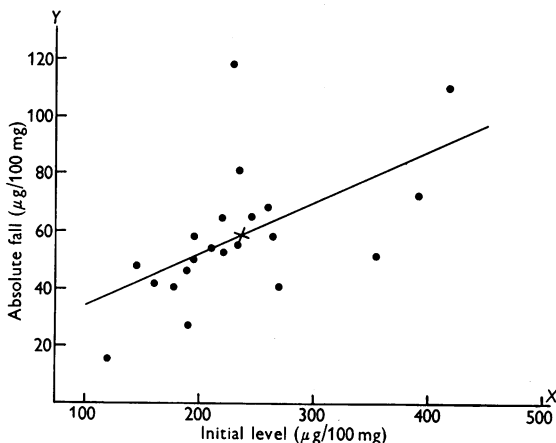

Text-fig. 9. Correlation between the initial concentration and absolute fall of the adrenal ascorbic acid in a group of 21 normal rabbits 1½ hr after unilateral adrenalectomy.

$$r = +0.57; Y = 0.18x + 15.6; S_y = \sigma_y \sqrt{(1-r^2)} = \pm 18.9.$$

RESULTS

Histology

(a) *Controls.* Histological study of serial sections (see Pl. 1, fig. 1) through the pituitary region of 21 of the normal control animals confirmed, but did not add to, the data presented by Green & Harris (1947) and Harris (1947).

(b) *Hypophysectomized.* Eight out of the 25 hypophysectomized rabbits were found to have remnants of pars distalis tissue and are termed 'incompletely hypophysectomized'. One animal out of the 17 included in the group 'completely hypophysectomized' possessed a fragment of neural lobe tissue only.

(c) *Stalk section.* The median eminence of the tuber cinereum of animals dying within 24 hr of stalk section or hypophysectomy was observed by naked eye, and under a binocular dissecting microscope, on many occasions and was found to be a red or plum-coloured, hardened nodule. This appearance stood in marked contrast to that of the surrounding hypothalamus which was white and soft. Examination of serial sections through such a median eminence revealed that the primary plexus of the hypophysial portal vessels was thrombosed.

Microscopic examination of the stalk-sectioned animals (all but 7 of which lived 80 days or longer) showed the median eminence to be a swollen, bulbous structure, as compared with the normal. This appearance was more marked in

the stalk-sectioned animals with plates. In all cases a high degree of vascularity was present, even in those animals in which the median eminence had been subjected to electrolytic cauterization at operation. The vascular pattern was, however, changed in that it consisted of a dense network of fine capillaries instead of the normal large, dilated, looped and twisted sinusoids (see Pls. 1 and 2).

The pars distalis of the pituitary showed no sign of necrosis or fibrosis and was well preserved and highly vascularized in 41 of the stalk-sectioned rabbits. In the remaining animal (subjected to simple stalk section) an obvious area of fibrosis existed in the central part of the gland.

The pars intermedia appeared thick and hypertrophied in the stalk-sectioned rabbits. The neural lobe was found to be markedly atrophic, and the pituitary stalk to have been completely sectioned, in all these animals.

Particular attention was paid to the possibility of regeneration of the hypophysial portal vessels across the fibrous region of the site of stalk section situated in all cases in the plane of the diaphragma sellae. Of the 11 'simple stalk-sectioned' rabbits used for experimental studies, 6 showed marked vascular regeneration (Pl. 1, figs. 2-4) in that large vessels, as well as many capillary connexions, were seen to connect the median eminence to the pars distalis. In 4 others of this group a large number of capillaries connected these two structures, whilst in the remaining rabbit (the animal showing the fibrous area in the pituitary) regenerated vascular connexions were probably represented by large sinusoidal vessels in the area of fibrosis. However, in this animal it was impossible to trace direct connexions since the vessels in the fibrous tissue were empty of injected ink. In the case of the 29 rabbits submitted to 'stalk section with plates' (Pl. 2, figs. 5-8) the waxed-paper plate was found to be correctly situated between the hypothalamus and the upper surface of the pituitary. Both the plate and the flattened wax pellet on its lower surface were found to be surrounded by a fibrous capsule in which was situated a fine capillary network. This plexus was in most cases in continuity with the primary plexus of vessels in the median eminence above, and with the pituitary blood vessels below. No apparent communication existed between the primary plexus and pars distalis in one animal. In the rest, however, it appeared that the vessels in the fibrous capsule surrounding the plate formed a meagre and fine capillary communication between the primary plexus and a tuft of capillaries situated in the antero-superior pole of the pars distalis.

Pituitary volumes

Pituitary stalk section resulted in some atrophy (to 68-83% of the normal volume) of the pars distalis and marked atrophy (to 26% of the normal volume) of the neural lobe. No significant difference was observed between the volumes of these lobes in the animals submitted to 'simple stalk section',

and 'stalk section with plate' with or without median eminence cauterization or ligation of the right internal carotid artery. For a more detailed account of the effect of stalk section on the volume of the median eminence and pituitary gland see Campbell & Harris (1957).

TABLE 1. The effect of pituitary stalk section on the lymphopenic and adrenal ascorbic acid responses to various stimuli. The combined adrenal and ovarian weights (expressed as fresh weight) are also given as are the findings for the normal and hypophysectomized controls. The figures represent the means \pm s.e. of the groups; in brackets, number of animals in group

Group	Lymphopenic response to				Ascorbic acid fall (%)	Combined adrenal wt. (mg)	Combined ovarian wt. (mg)
	Restraint	Cold	Adrenaline	Laparotomy			
Normal controls	52.3 \pm 4.8 (12)	43.7 \pm 5.1 (12)	55.3 \pm 3.0 (12)	68.7 \pm 4.2 (9)	25.0 \pm 1.8 (21)	479.5 \pm 25.7 (33)	588.5 \pm 91.7 (11)
Hypophysectomy							
Incomplete	—	—	27.8 \pm 7.0 (7)	40.1 \pm 2.5 (6)	+4.1 \pm 2.9 (3)	281.5 \pm 38.2 (7)	155.5 \pm 22.7 (7)
Complete	—	—	+4.4 \pm 3.0 (13)	+3.9 \pm 8.5 (6)	2.2 \pm 4.0 (4)	202.9 \pm 32.2 (7)	130.5 \pm 19.5 (9)
stalk section							
With plate	7.7 \pm 4.3 (22)	8.5 \pm 2.7 (22)	42.7 \pm 3.3 (22)	40.3 \pm 4.4 (19)	19.1 \pm 2.0 (17)	271.6 \pm 20.1 (19)	154.3 \pm 23.4 (22)
No plate	10.2 \pm 6.6 18-35 days (11)	—	—	—	—	269.9 \pm 16.3 (11)	—
	33.3 \pm 5.6 43-59 days (11)	—	—	—	—	—	326.4 \pm 53.1 (11)
	33.5 \pm 5.4 (11)	—	—	—	—	—	431.2 \pm 72.7* (6)
							207.8 \pm 20.0† (4)

* Six rabbits with marked portal vessel regeneration.

† Four rabbits with less portal vessel regeneration.

Lymphopenic responses

(a) *Intact controls.* Forty-five tests were performed on 16 animals. A marked lymphopenia occurred in 44 cases (Table 1).

(b) *Hypophysectomized controls.* Since it has been established that the lymphopenic response to emotional stress in the rabbit is abolished by hypophysectomy (Colfer *et al.* 1950), observations were limited to the effects of injection of adrenaline and laparotomy. Nineteen tests were performed on 15 completely hypophysectomized rabbits and 13 tests on 8 incompletely hypophysectomized animals. No lymphopenic response to adrenaline or laparotomy occurred in the completely hypophysectomized animals, but a significant lymphopenia was observed (except in one test) in the incompletely hypophysectomized group.

(c) *Stalk-sectioned animals.* 'With plates.' Significant lymphopenic responses (> 15%) occurred in 5 out of 22 animals after restraint, in 5 out of 22 after exposure to cold, in 20 out of 22 after injection of adrenaline and in 16 out of

19 after laparotomy. Considering this group as a whole (Table 1) the lymphopenic effect of restraint and cold was reduced to insignificant levels, whereas a significant though reduced lymphopenia resulted from adrenaline and laparotomy.

'Without plates.' In 11 of these rabbits the lymphopenic response to the stimulus of restraint was observed at three different periods (18-35 days, 43-59 days and 76-86 days) after operation. On the first occasion 4 rabbits gave a significant response with a group mean of 10.2% (± 6.6), on the second occasion 10 rabbits responded with a group mean of 33.3% (± 5.6), and on the third occasion 9 rabbits responded with a mean of 33.5% (± 5.4).

Adrenal ascorbic acid

(a) *Intact controls.* In 21 tests the mean adrenal ascorbic acid concentration fell from a value of 236 ± 12 to 178 ± 14 $\mu\text{g}/100$ mg adrenal gland ($P < 0.01$), $1\frac{1}{2}$ hr after unilateral adrenalectomy, a fall of $25.0 \pm 1.8\%$ (see Table 1).

(b) *Hypophysectomized controls.* No fall of the adrenal ascorbic acid concentration occurred in either the completely (4) or the incompletely (3) hypophysectomized animals tested. The mean initial level was found, in both groups, to be significantly higher than in the controls.

(c) *Stalk-sectioned animals.* 'With plates.' A fall in the adrenal ascorbic acid concentration was observed in 16 out of the 17 animals tested. In the whole group there was a fall from the mean initial level of 269 ± 20 to 215 ± 15 $\mu\text{g}/100$ mg adrenal gland ($P < 0.05$). The mean difference (54 ± 9) between the initial and final levels approximates to the corresponding value in the controls (58 ± 5), although it appears smaller when expressed as a percentage of the initial level ($19.1 \pm 2.0\%$, compared to $24.9 \pm 1.9\%$ in the controls). The mean initial level (269 ± 20) was intermediate to the corresponding values observed in the intact (236 ± 16) and hypophysectomized (328 ± 28) controls. There was no correlation between the individual ascorbic acid responses and the pituitary volumes in the stalk-sectioned animals.

Adrenal weights

The mean combined adrenal weights of the different groups of rabbits are given in Table I. It should be remarked that, for reasons of animal accommodation, it was not possible to maintain the normal control animals in the constant-temperature room for the same length of time as the operated animals. For this reason the adrenal atrophy following pituitary stalk section or hypophysectomy may be less than that represented in Table 1. No relationship was observed between regeneration of the hypophysial portal vessels and adrenal gland weight.

Reproductive organs

All animals (except 12 intact controls) were placed with a male 48 hr before killing. The ovaries and genital tracts were observed post mortem. The average ovarian weights of animals in the different groups are given in Table 1.

(a) *Intact controls.* Twenty-one intact control rabbits were placed with a male 48 hr before killing (the occurrence of mating was not recorded). Of these, 15 were found to have freshly ruptured follicles after death. Twelve other intact controls were killed and their ovaries weighed. One of these latter was found to be pseudopregnant and its ovarian weight is not included in the mean figure given in Table 1.

(b) *Hypophysectomized controls.* The mean ovarian weights of rabbits which lived more than 40 days after hypophysectomy are given in Table 1. There is no significant difference in the ovarian weights of the completely and incompletely hypophysectomized groups.

(c) *Stalk-sectioned group.* 'Stalk-sectioned with plate.' The ovarian weights of these animals do not differ significantly from the completely hypophysectomized group.

'Simple stalk section.' The average ovarian weight of this group was intermediate between the hypophysectomized controls and the normal controls. The 6 animals showing the greatest degree of hypophysial portal vessel regeneration had a mean ovarian weight of 431.2 ± 72.7 mg, whereas the other 4 (excluding the animal with an area of pituitary fibrosis) had a mean ovarian weight of 207.8 ± 20.0 mg. The difference between these two groups was significant ($P < 0.05$). The difference between the ovarian weights of the 6 rabbits with the most marked portal vessel regeneration and that of the intact controls was not significant ($P > 0.2$), and the difference between the ovarian weights of the 4 animals with less regeneration and the completely hypophysectomized controls was significant ($P < 0.05$).

Body weight

There was no significant alteration of the body weight of stalk-sectioned, completely or incompletely hypophysectomized animals during the period of observation, whereas the intact controls showed an average increase of 550 g during the same time interval.

DISCUSSION

Section of the pituitary stalk is one of four procedures—the others being transplantation of the gland to a remote site in the body, electrolytic or surgical destruction of the whole or part of the hypothalamus, and culture of the gland *in vitro*—which have been used to study the function of the pituitary gland isolated from the central nervous system. With regard to the adrenocorticotrophic, as well as the other activities of the gland, the results yielded

by this method have been confusing. Uotila (1939) reported that the adrenal enlargement consequent on exposure to cold was not prevented in the rat by section of the pituitary stalk. In the hands of other workers this procedure equally failed to suppress the adrenal hypertrophy elicited by cold in the rat (Barnett & Greep, 1951) and dog (Keller & Breckenridge, 1947), the cold-induced adrenal cholesterol depletion in the guinea-pig (Tang & Patton, 1951) and the adrenal ascorbic acid response to unilateral adrenalectomy combined with the injection of histamine (Cheng, Sayers, Goodman & Swinyard, 1949*a*) or exposure to cold (Fortier & Selye, 1949) in the rat. It has since been shown that regeneration of the portal vessels across the site of stalk section occurs in the rat (Harris, 1950; Harris & Jacobsohn, 1950), mouse (de Groot, 1952), rabbit (Jacobsohn, 1954), ferret (Thomson & Zuckerman, 1954; Donovan & Harris, 1956), and monkey (Harris & Johnson, 1950) and it has been suggested (Harris, 1948*a*, 1955) that the re-establishment of this vascular link between the hypothalamus and adeno-hypophysis may account for the persistence of the adrenocorticotrophic response to stress. In an attempt to prevent this occurrence in the dog, Hume (1952) placed a polythene sheet between the cut ends of the stalk and observed, nevertheless, a normal eosinopenic response to operative trauma or adrenaline injection. For lack of a detailed histological study, in the author's own words: 'It cannot be conclusively stated that the hypophysial vessels had not regrown'. De Groot & Harris (1950) observed, however, that electrolytic lesions placed in the path of the portal vessels (in the zona tuberalis of the rabbit's pituitary) abolished the lymphopenia that normally follows emotional stress, although lesions of a similar nature in the centre of the gland had no effect. Likewise, McCann (1953) reported that the adrenal ascorbic acid responses to unilateral adrenalectomy or the eosinopenia induced by adrenaline were prevented in the rat by extensive electrolytic destruction of the pituitary stalk.

In the present study the rabbit was chosen as the experimental animal since it has a relatively large systemic arterial supply to the pars distalis of the pituitary in addition to the portal supply (Harris, 1947). Radical steps were taken to prevent portal vessel regeneration. The incidence of such regeneration, and of any pituitary atrophy following stalk section, was evaluated by a final histological study of thick serial sections from indian ink injected material. Widely different stressing stimuli, calculated to belong to the neurotropic or systemic types (Fortier, 1951), were used.

In spite of the systemic arterial supply to the anterior lobe of the rabbit's pituitary, stalk section resulted in some atrophy of this gland. The volume of the pars distalis was found to be approximately 70-80% of the normal after stalk section. This volume of anterior lobe tissue (if left in connexion with the pituitary stalk—as judged by the results of incomplete hypophysectomy) should be sufficient to maintain normal function of the gland. As expected

from the work of Fisher, Ingram & Ranson (1938) and many other workers, the neural lobe was markedly atrophic (26% of normal volume). Varying degrees of portal vessel regeneration occurred in all but a few animals. The significance of this regeneration when it consists of a small number of fine capillaries situated in the fibrous capsule around a plate between the stalk ends, is unknown. A similar type of regeneration has been seen following stalk section in the monkey with the insertion of a plate between the hypothalamus and pituitary gland (D. M. Hume, personal communication). The grossly enlarged and highly vascularized median eminence observed in the stalk-sectioned rabbits with plates is reminiscent of the findings of Stutinsky (1951) and Billenstien & Leveque (1955). The detailed histology and functional significance of this structure require further study.

The stalk-sectioned rabbits showed, in general, a characteristic ACTH response pattern to stress stimuli. In those animals in which marked portal vessel regeneration was observed (mostly those without plates) a lymphopenic response to the neural stimulus of restraint occurred. On the other hand, in those animals in which little, or no, portal vessel regeneration occurred, the lymphopenic response to the nervous stimuli of restraint or exposure to cold was nearly abolished, although the responses to tissue trauma (laparotomy, unilateral adrenalectomy) or metabolic disturbance (injection of adrenaline) were hardly altered. There would seem, then, to be a correlation between regeneration of the hypothalamo-hypophysial neurovascular connexions and the return of the ACTH response to stimuli which might be supposed to act through the nervous system.

The persistence of a significant adrenocorticotrophic response to physical stimulation, in spite of adrenal atrophy and alteration of the pituitary volume, has been previously observed in the case of hypophysectomized rats bearing extrasellar pituitary transplants. The pituitary, grafted in these animals outside the reach of the portal vessels, underwent a marked involution, characterized by fibrotic invasion of the parenchyma and an increased chromophobic/chromophil cell ratio (Cheng *et al.* 1949*b*; Fortier, 1952) and failed to maintain adrenal weight (Cheng *et al.* 1949*b*; Fortier, 1951; Fortier & Selye, 1949; Harris & Jacobsohn, 1952). It was, nevertheless, shown capable of responding with a release of ACTH to the combined stress stimuli of unilateral adrenalectomy and histamine injection (Cheng *et al.* 1949*b*) or unilateral adrenalectomy and exposure to cold (Fortier & Selye, 1949) as evidenced by a fall of the adrenal ascorbic acid concentration. The subcutaneous injection of adrenaline, or even of hypertonic saline, was reported to result in a significant fall of the blood eosinophiles in pituitary-grafted animals (McDermott *et al.* 1950*b*). It was later suggested that the ability of transplants to release ACTH depended on the type of stimulation used as a stressing procedure. Fortier (1951) reported that hypophysectomized rats bearing intra-ocular pituitary transplants, while

still showing an eosinopenic response to so-called *systemic* stimuli (cold, administration of adrenaline or histamine) failed to give any evidence of ACTH release in response to nervous or emotional stimuli (intense sound, immobilization on a board). It was suggested, in view of these findings, that the hypothalamo-hypophysial pathways are required for pituitary activation in response to *neurotropic* (nervous or emotional) stress; whereas the corticotrophic effect of *systemic* stress is mediated through various humoral changes (such as variations in the level of circulating adrenal cortical hormones or the discharge of adrenaline or histamine) acting either independently or concurrently on the pituitary to elicit the release of ACTH. Our present findings, which illustrate a similar dissociation in the response to different types of stress,* support this view, which is also compatible with the loss of the lymphopenic response to emotional stress after lesions in the posterior tuber cinereum of the rabbit (de Groot & Harris, 1950), and the retention of the eosinopenic response to surgical trauma after ventral hypothalamectomy in the dog (Keller, Lynch, Batsel, Witt & Galvin, 1954). In contradiction with this interpretation, however, Hume (1953), working with dogs, and Porter (1953, 1954), with cats and monkeys, reported that electrolytic lesions placed in the median eminence, posterior tuber cinereum or mammillary bodies effectively prevented the eosinopenia induced by surgical trauma. The eosinopenic responses to injection of adrenaline and insulin (Porter, 1953) or the adrenal enlargement consequent on unilateral adrenalectomy (Ganong & Hume, 1954) were also prevented by this intervention. McCann (1953) likewise reported that massive destruction of the median eminence prevented the eosinopenia or adrenal ascorbic acid depletion induced by adrenaline administration or unilateral adrenalectomy in the rat. Lesions restricted to the anterior part of the median eminence were found by Hume & Nelson (1955) to prevent the rise in concentration of blood ACTH or adrenal vein corticoids after surgical trauma. McCann & Sydnor (1955) claimed that lesions interrupting the supraoptico-hypophysial tract abolished the adrenal ascorbic acid response to unilateral adrenalectomy and prevented the rise of blood ACTH concentration in adrenalectomized rats subjected to the acute stress of ether anaesthesia and bleeding.

It is difficult to reconcile these latter findings with our own observations in the stalk-sectioned rabbit, or with the result seen after pituitary transplantation in the rat. The lack of complete histological examination of the pituitary region in most of the studies concerned with the effect of hypothalamic lesions does not exclude the possibility of interference with the blood supply of the

* They differ, however, with respect to the adrenocorticotrophic effect of cold, reportedly maintained in the pituitary-grafted rat (Fortier, 1951) but either abolished or markedly decreased in the stalk-sectioned rabbit. As a possible explanation, cold was observed to cause less obvious physical disturbance in the rabbit than in the rat.

pituitary, and consequent fibrosis of the gland, although the occurrence of normal (McCann, 1953) or even increased (McCann & Sydnor, 1955; McCann & Brobeck, 1955) adrenal weight under these conditions makes it unlikely. As another possible, but equally unlikely, explanation McCann (1953) suggested that: 'A neurohumoral substance is released in the median eminence which normally traverses the hypophysial portal vessels and causes release of ACTH. In cases of severe stress sufficient amounts of this substance may be released to activate the anterior lobe via the general circulation.' According to this view the response of the isolated pituitary would not depend on the nature but on the relative intensity of the stimuli, which would, in all cases, act through the hypothalamus. The final elucidation of this problem awaits further experiment.

It is of interest that the responses to 'neural stresses' recurred, in rabbits in which the ultimate histological examination revealed well-marked portal vessel regeneration, some 20-40 days after stalk section. It may be that this vascular regeneration occurs more slowly in the rabbit than in the rat (Harris, 1950), though this finding may represent differences in the technique of stalk section rather than a species difference.

The adrenal weight probably bears a close relationship to the rate of ACTH secretion under resting conditions. The mean combined adrenal weight of the stalk-sectioned rabbits (271.6 ± 20.1 , and 269.9 ± 16.3 mg) was considerably lower than in the intact controls (479.5 ± 25.7 mg), although higher than in the completely hypophysectomized animals (202.9 ± 32.2 mg) (Table 1). No relationship was observed between the incidence of hypothalamo-hypophysial vascular connexions and the degree of adrenal atrophy, though such has been previously observed in the ferret (Donovan & Harris, 1956). No significant correlation was found between anterior pituitary volume and adrenal weight, nor between the latter and the lymphopenic responses to any stimulus, or the adrenal ascorbic acid response to unilateral adrenalectomy.

The ovarian weights of the animals in the different groups showed a direct correlation with the presence of vascular connexions between the median eminence of the tuber cinereum and the pars distalis of the adeno-hypophysis. The ovarian weight of the 6 stalk-sectioned animals with the greatest degree of portal vessel regeneration did not differ significantly from the normal controls. Four of these animals accepted the male 48 hr before being killed, and 2 of them ovulated.

In summary, it may be said that the present findings support the view that the anatomical structures by which the hypothalamus influences anterior pituitary secretion are the hypophysial portal vessels. Permanent interruption of these vessels appears to lower the basal rate of secretion of ACTH, prevents nervous reflex activation of this secretion in response to stress, and abolishes

secretion of gonadotrophic hormone. The secretion of this latter hormone seems to be entirely dependent on intact hypothalamo-hypophysial connexions, whereas a residual secretion of ACTH, which may be modified by certain types of stress, remains in the absence of these connexions.

SUMMARY

1. The pituitary stalk was divided in 42 rabbits, using a fronto-temporal approach. A waxed-paper plate was inserted between the cut ends in 29 of these animals. Groups of these rabbits were used for investigating (a) the effects of a variety of stress stimuli in activating the pituitary-adrenal axis, and (b) the effect of pituitary stalk section on pituitary volume, adrenal gland weight and ovarian activity and weight. The results of these observations were compared with similar observations in 37 normal rabbits and 25 hypophysectomized animals.

2. Examination of thick serial sections through the pituitary region of the stalk-sectioned rabbits revealed that regeneration of the hypophysial portal vessels had occurred to a marked extent in 'simple stalk-sectioned' animals, and to a slight and variable degree in 'stalk-sectioned animals with plates.'

3. Stalk section followed by little or no regeneration of the portal vessels reduced or abolished the lymphopenic response to restraint and exposure to cold, but exerted little effect on the response to injection of adrenaline or laparotomy or on the adrenal ascorbic acid depletion following unilateral adrenalectomy. These findings support the view that environmental stimuli may be divided into two types: those that affect ACTH secretion solely by an action through the central nervous system, and those that act also by affecting the composition of the blood in the systemic circulation.

4. A correlation was found between the incidence of portal vessel regeneration and the recurrence of the lymphopenic response to the stress of restraint.

5. A significant degree of adrenal atrophy was observed to follow pituitary stalk section in all animals.

6. Ovarian atrophy following stalk section was limited to those cases in which portal vessel regeneration was effectively prevented. The 6 animals in which the greatest degree of portal vessel regeneration occurred showed ovaries of normal weight, and 2 of these animals showed the usual reflex response of ovulation consequent on coitus. Marked atrophy of the ovaries and genital tract was observed in those animals subjected to stalk section in which little or no portal vessel regeneration occurred.

7. These findings are discussed in the light of previous studies on the effect of stalk section, pituitary transplantation and hypothalamic lesions.

Our thanks are due to Mr G. J. Christofinis and Mr S. A. Renner for their valuable technical assistance and for the preparation of histological material. The expenses of this research were in

part defrayed by grants to one of us (G. W. H.) from the Foulerton Gift Fund of the Royal Society and the Research Fund of the Bethlem Royal and Maudsley Hospital. This work was done during the tenure (by I. R. M.) of a C. J. Martin Research Fellowship and (by C. F.) of a Fellowship from the American Heart Association (1953-4) and from the Commonwealth Fund (1954-5) which we gratefully acknowledge.

REFERENCES

- BARNETT, R. J. & GREEP, R. O. (1951). Regulation of secretion of adrenotropic and thyrotropic hormone after stalk section. *Amer. J. Physiol.* **167**, 569-575.
- BILLENSTIEN, D. C. & LEVEQUE, T. F. (1955). The reorganization of the neurohypophyseal stalk following hypophysectomy in the rat. *Endocrinology*, **56**, 704-717.
- BROWN-GRANT, K., HARRIS, G. W. & REICHLIN, S. (1957). The effect of pituitary stalk section on thyroid function in the rabbit. *J. Physiol.* **136**, 364-379.
- CAMPBELL, H. J. & HARRIS, G. W. (1957). The volume of the pituitary and median eminence in stalk-sectioned rabbits. *J. Physiol.* **136**, 333-343.
- CHENG, C. P., SAYERS, G., GOODMAN, L. S. & SWINYARD, C. A. (1949a). Discharge of adrenocorticotrophic hormone in the absence of neural connections between the pituitary and hypothalamus. *Amer. J. Physiol.* **158**, 45-50.
- CHENG, C. P., SAYERS, G., GOODMAN, L. S. & SWINYARD, C. A. (1949b). Discharge of adrenocorticotrophic hormone from transplanted pituitary tissue. *Amer. J. Physiol.* **159**, 426-432.
- COLFER, H. F., DE GROOT, J. & HARRIS, G. W. (1950). Pituitary gland and blood lymphocytes. *J. Physiol.* **111**, 328-334.
- DE GROOT, J. (1952). *The Significance of the Portal System*. Thesis for M.D. degree, University of Amsterdam. Van Gorcum and Co.
- DE GROOT, J. & HARRIS, G. W. (1950). Hypothalamic control of the anterior pituitary and blood lymphocytes. *J. Physiol.* **111**, 335-346.
- DONOVAN, B. T. & HARRIS, G. W. (1956). The effect of pituitary stalk section on light-induced oestrus in the ferret. *J. Physiol.* **131**, 102-114.
- DOUGHERTY, T. F. & WHITE, A. (1944). Influence of hormones on lymphoid tissue structure and function. The role of the pituitary adrenotropic hormone in the regulation of the lymphocytes and other cellular elements of the blood. *Endocrinology*, **35**, 1-14.
- ENGELBRETH-HOLM, J. & PLUM, C. M. (1951). A rapid and easy method of decalcification. *J. Path. Bact.* **63**, 751-753.
- FISHER, C., INGRAM, W. R. & RANSON, S. W. (1938). *Diabetes Insipidus and the Neuro-hormonal Control of Water Balance*. Ann Arbor, Michigan: Edward Bros. Inc.
- FORTIER, C. (1951). Dual control of adrenocorticotrophin release. *Endocrinology*, **49**, 782-788.
- FORTIER, C. (1952). Studies on the control of ACTH release by means of hypophyseal transplants. *Ciba Foundation Colloquia on Endocrinology*, **4**, 124-136.
- FORTIER, C. & SELYE, H. (1949). Adrenocorticotrophic effect of stress after severance of the hypothalamo-hypophysial pathways. *Amer. J. Physiol.* **159**, 433-439.
- GANONG, W. F. & HUME, D. M. (1954). Absence of stress-induced and 'compensatory' adrenal hypertrophy in dogs with hypothalamic lesions. *Endocrinology*, **55**, 474-483.
- GREEN, J. D. & HARRIS, G. W. (1947). The neurovascular link between the neurohypophysis and adenohypophysis. *J. Endocrin.* **5**, 136-146.
- HARRIS, G. W. (1947). The blood vessels of the rabbit's pituitary gland and 'the significance of the pars and zona tuberalis'. *J. Anat., Lond.*, **81**, 343-351.
- HARRIS, G. W. (1948a). Neural control of the pituitary gland. *Physiol. Rev.* **28**, 139-179.
- HARRIS, G. W. (1948b). Electrical stimulation of the hypothalamus and the mechanism of neural control of the adenohypophysis. *J. Physiol.* **107**, 418-429.
- HARRIS, G. W. (1950). Oestrous rhythm, pseudopregnancy and the pituitary stalk in the rat. *J. Physiol.* **111**, 347-360.
- HARRIS, G. W. (1955). *Neural Control of the Pituitary Gland*. London: Edward Arnold Ltd.
- HARRIS, G. W. & JACOBSON, D. (1950). Proliferative capacity of the hypophysial portal vessels. *Nature, Lond.*, **165**, 854.
- HARRIS, G. W. & JACOBSON, D. (1952). Functional grafts of the anterior pituitary gland. *Proc. Roy. Soc. B*, **139**, 263-276.
- HARRIS, G. W. & JOHNSON, R. T. (1950). Regeneration of the hypophysial portal vessels, after section of the hypophysial stalk in the monkey (*Macacus rhesus*). *Nature, Lond.*, **165**, 819.

- HARRIS, G. W. & POPA, G. T. (1938). A technique for operations on the hypothalamo-hypophysial region of the rabbit. *J. Anat., Lond.*, **72**, 226-233.
- HUME, D. M. (1952). The relationship of the hypothalamus to the pituitary secretion of ACTH. *Ciba Foundation Colloquia on Endocrinology*, **4**, 87-99.
- HUME, D. M. (1953). The neuroendocrine response to injury: present status of the problem. *Ann. Surg.* **138**, 548-557.
- HUME, D. M. & NELSON, D. H. (1955). Effect of hypothalamic lesions on blood ACTH levels and 17-hydroxycorticosteroid secretion following trauma in the dog. *J. Clin. Endocrin.* **15**, 839-840.
- HUME, D. M. & WITTENSTEIN, G. J. (1950). The relationship of the hypothalamus to pituitary-adrenocortical function. *Proc. 1st Clin. ACTH Conf.* pp. 134-146. J. R. Mote, ed. Philadelphia: Blakiston and Co.
- JACOBSON, D. (1954). Regeneration of hypophysial portal vessels and grafts of anterior pituitary glands in rabbits. *Acta endocr., Copenhagen*, **17**, 187-197.
- JACOBSON, D. & WESTMAN, A. (1940). A parapharyngeal method of hypophysectomy in rabbits. *Acta physiol. scand.* **1** (fasc. 1), 71-78.
- KELLER, A. D. & BRECKENRIDGE, C. G. (1947). Retention of normal insulin tolerance and adrenal cortex following extirpation of hypophysial stalk in the dog. *Amer. J. Physiol.* **150**, 222-228.
- KELLER, A. D., LYNCH, J. R., BATSEL, H. L., WITT, D. M. & GALVIN, R. D. (1954). Anatomical and functional integrity of the adrenal cortices not dependent on structural integrity of the ventral hypothalamus. *Amer. J. Physiol.* **179**, 5-14.
- LAQUEUR, G. L., McCANN, S. M., SCHREINER, L. H., ROSEMBERG, E., RIOCH, D. M. & ANDERSON, E. (1953). Alterations of adrenal cortical and ovarian activity following hypothalamic lesions. *Endocrinology*, **57**, 44-54.
- McCANN, S. M. (1953). Effects of hypothalamic lesions on the adrenal cortical response to stress in the rat. *Amer. J. Physiol.* **175**, 13-20.
- McCANN, S. M. & BROBECK, J. R. (1955). Evidence for a role of the supraopticohypophysial system in regulation of adrenocorticotrophin secretion. *Proc. Soc. exp. Biol., N.Y.*, **88**, 318-323.
- McCANN, S. M. & SYDNOR, K. L. (1955). Blood and pituitary adrenocorticotrophin in adrenalectomized rats with hypothalamic lesions. *Proc. Soc. exp. Biol., N.Y.*, **88**, 369-373.
- McDERMOTT, W. V., FRY, E. G., BROBECK, J. R. & LONG, C. N. H. (1950a). Mechanism of control of adrenocorticotrophic hormone. *Yale J. Biol. Med.* **23**, 52-66.
- McDERMOTT, W. V., FRY, E. G., BROBECK, J. R. & LONG, C. N. H. (1950b). Release of adrenocorticotrophic hormone by direct application of epinephrine to pituitary grafts. *Proc. Soc. exp. Biol., N.Y.*, **73**, 609-610.
- PORTER, R. W. (1953). Hypothalamic involvement in the pituitary-adrenocortical response to stress stimuli. *Amer. J. Physiol.* **172**, 515-519.
- PORTER, R. W. (1954). The central nervous system and stress-induced eosinopenia. *Recent Progr. Hormone Res.* **10**, 1-18.
- ROE, J. H. & KUETHER, C. A. (1943). The determination of ascorbic acid in whole blood and urine through the 2:4-dinitrophenylhydrazine derivative of dehydroascorbic acid. *J. biol. Chem.* **147**, 399-407.
- SAYERS, G., SAYERS, M. A., LIANG, T. Y. & LONG, C. N. H. (1946). The effect of pituitary adrenocorticotrophic hormone on the cholesterol and ascorbic acid content of the adrenal gland of the rat and the guinea pig. *Endocrinology*, **38**, 1-9.
- SAYERS, M. A., SAYERS, G. & WOODBURY, L. A. (1948). The assay of adrenocorticotrophic hormone by the adrenal ascorbic acid depletion method. *Endocrinology*, **42**, 379-393.
- STUTINSKY, F. (1951). Sur l'origine de la substance Gomori-positive du complexe hypothalamo-hypophysaire. *C.R. Soc. Biol., Paris*, **145**, 367-370.
- TANG, P. C. & PATTON, H. D. (1951). Effect of hypophysial stalk section on adeno-hypophysial function. *Endocrinology*, **49**, 86-98.
- THOMSON, A. P. D. & ZUCKERMAN, S. (1954). The effect of pituitary-stalk section on light-induced oestrus in ferrets. *Proc. Roy. Soc. B*, **142**, 437-451.
- UOTILA, U. U. (1939). On the role of the pituitary stalk in the regulation of the anterior pituitary, with special reference to the thyrotrophic hormone. *Endocrinology*, **25**, 605-614.
- WESTMAN, A. & JACOBSON, D. (1940). Endokrinologische Untersuchungen an Kaninchen mit durchtrenntem Hypophysenstiel. *Acta obstet. gynec. scand.* **20**, 392-433.

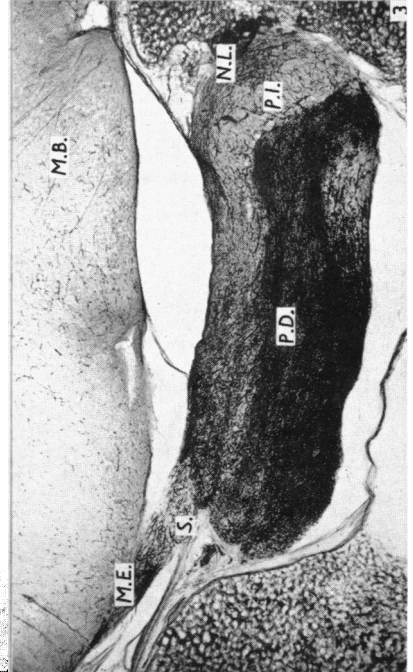
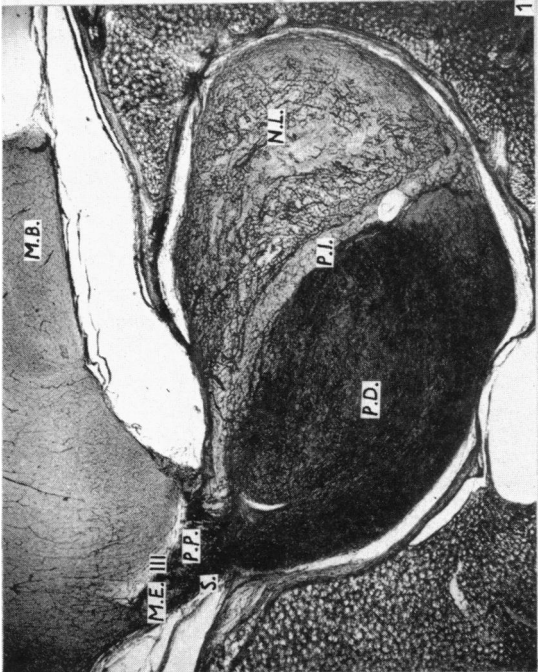
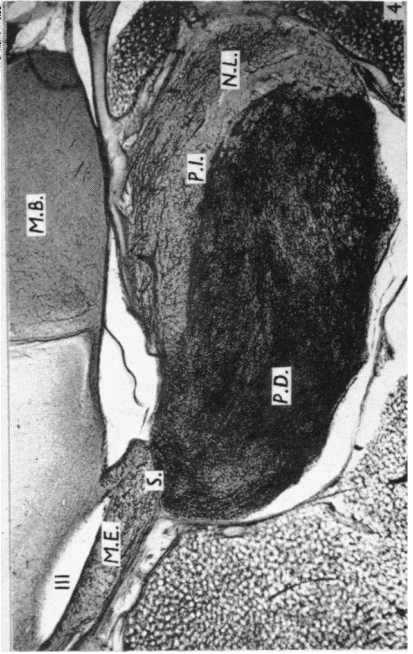
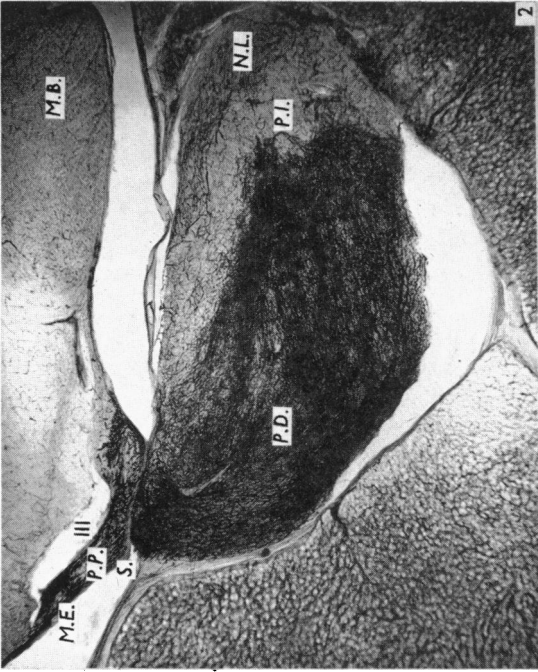

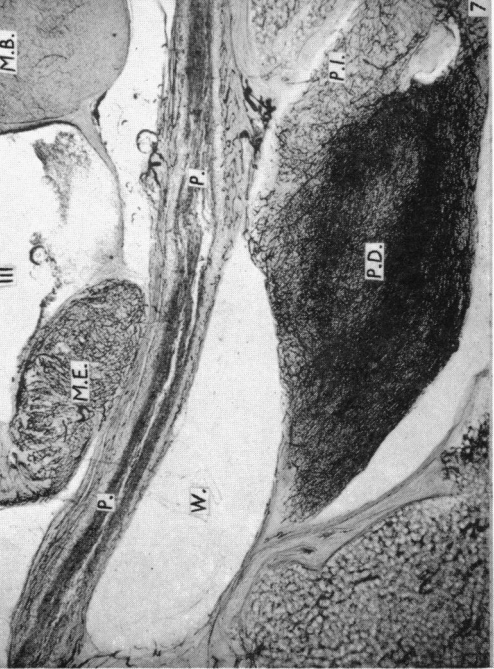
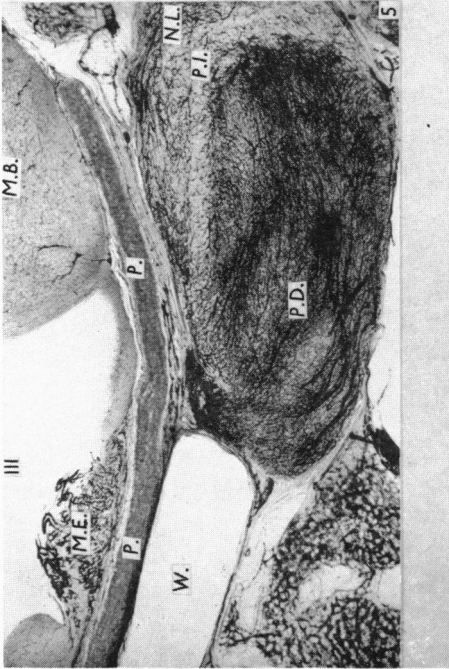
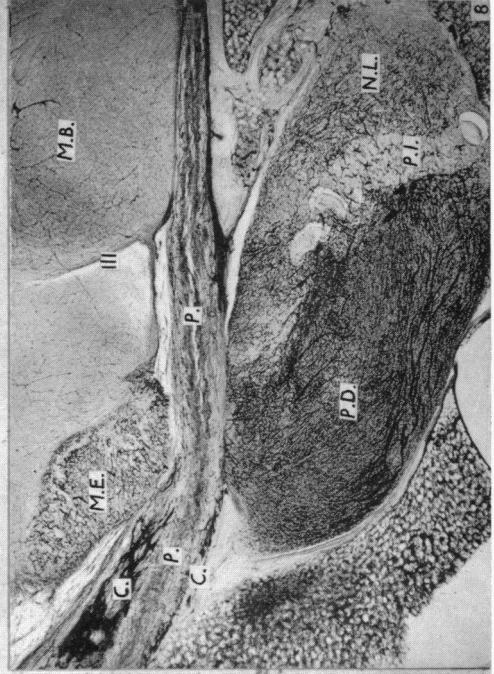
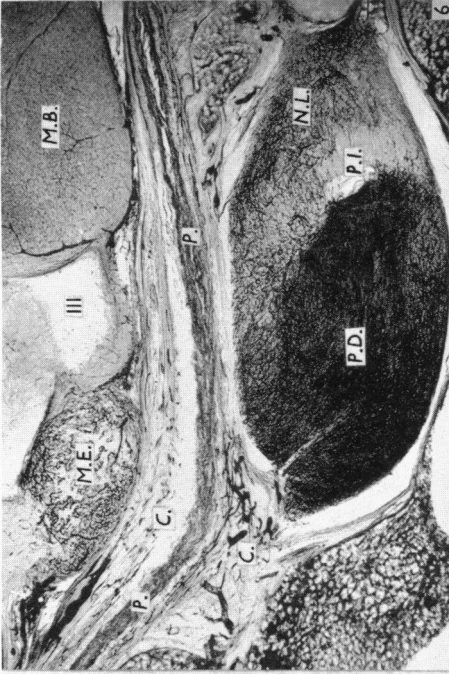

EXPLANATION OF PLATES

Photomicrographs of mid-line sagittal sections through the hypothalamus, pituitary gland and base of skull of rabbits after perfusion of the vascular system with indian ink. All sections 200μ thick and stained with haematoxylin and eosin: magnification $\times 15$. *C.*, capillary connexions; *M.B.*, mammillary body; *M.E.*, median eminence; *N.L.*, neural lobe; *O.C.*, optic chiasma; *P.*, waxed-paper plate; *P.D.*, pars distalis; *P.I.*, pars intermedia; *P.P.*, primary plexus of portal vessels; *P.V.*, portal vessels; *S.*, pituitary stalk; *W.*, wax pellet; III, third ventricle.

PLATE 1

Fig. 1. Normal rabbit. To illustrate the vascular connexions between the median eminence and the pars distalis, and to show the differences in vascular patterns of the pars distalis, pars intermedia and neural lobe.

Figs. 2-4. 'Simple stalk-sectioned rabbits.' Note the plane of stalk section at the level of the diaphragma sellae, the continuity of the vascular fields of the median eminence and pars distalis, the relatively well maintained and highly vascular pars distalis as compared with the atrophic neural lobe, and the change in vascular pattern of the primary plexus (compare with Fig. 1).

PLATE 2

Figs. 5-8. Stalk-sectioned rabbits with plates. Note the waxed-paper plate intervening between the hypothalamus and median eminence above, and the pituitary gland below. In the fibrous capsule surrounding the plate a number of fine capillaries are visible. The anterior lobes are well maintained and highly vascular as compared with the neural lobes. The enlarged and bulbous median eminence shows a vascular pattern different from the normal, as shown by comparison with Pl. 1, fig. 1. It may be seen that the median eminence is also larger than that of the simple stalk-sectioned animals (Pl. 1, figs. 2-4). The site of the waxed pellets inserted between the anterior clinoid processes in some rabbits is shown in Figs. 5 and 7.