

Obtaining a functional recombinant anti-rhesus (D) antibody using the baculovirus–insect cell expression system

L. EDELMAN,* C. MARGARITTE,* H. CHAABIHI,† E. MONCHÂTRE,* D. BLANCHARD,‡ A. CARDONA,* F. MORIN,§ G. DUMAS,* S. PETRES* & M. KACZOREK† *Institut Pasteur, Laboratoire de Technologie Cellulaire, Paris, †Proteine Performance, Christol les Alès, ‡CRTS, Nantes, and §CDTS,-Hôpital Avicenne, Bobigny, France

SUMMARY

The cloning and production of a human anti-rhesus (Rh) D monoclonal antibody (mAb) using the baculovirus–insect cell expression system is described. This monoclonal recombinant antibody R.D7C2 derived from a human parental IgM λ immunoglobulin was obtained after immortalization of lymphocytes by Epstein–Barr virus (EBV). The human heavy (VH) and light (VL) variable regions were cloned from the parental cell line and genetically fused to the human constant IgG1 heavy (H) and light (L) chain genes (γ 1 and λ , respectively). A recombinant baculovirus was constructed that directs the co-expression of genes encoding both genetically fused heavy and light chains under the control of two late and strong baculovirus promoters. After infecting the *Spodoptera frugiperda* (Sf9) insect cell line with this baculovector, a complete IgG1 mAb was secreted in the culture medium indicating that each immunoglobulin chain was correctly processed and assembled with a functional glycosylation into a tetrameric form. *In vitro* analysis showed that the functional properties of R.D7C2 using agglutination tests were efficient for the specific recognition of Rh-D-positive red blood cells (RBC). In addition, R.D7C2 showed effector functions of the γ 1 heavy chain resulting in the lysis of Rh⁺ papain RBC by an antibody-directed cellular cytotoxicity mechanism. These results demonstrate that R.D7C2 can be produced in the baculovirus–insect cell expression system as a source for potential therapeutic application in the treatment of the haemolytic disease of the newborn.

INTRODUCTION

Although mouse monoclonal antibodies (mAb) with a high neutralizing activity are being tested for human therapy, their application is severely limited by the immune response to the mouse protein, a reduced half-life of the mouse mAb in humans and the poor recognition of effector domains of the mouse antibody by the human system.¹ A major drawback is that repeated injections with non-human antibodies induce an anti-isotypic immune response which prevents their long-term use in human patients.^{2,3} To circumvent this problem, chimeric and humanized forms of immunoglobulins have been genetically engineered. Chimeric antibodies combine the variable (V) regions of the mouse mAb responsible for the binding of the antigen, with the human constant (C) regions responsible for effector functions⁴ whereas humanized mAb is the result

of the grafting of complementary determined regions (CDR) of murine origin grafter into human frameworks. The immunogenicity of such immunoglobulins is reduced compared to that of their murine counterpart, thus reducing the anti-isotypic immune response.⁵ Ultimately, totally human mAb produced by genetic engineering would provide human antibodies and avoid immunogenicity. In addition, the human C regions which are present in these molecules are expected to provide efficient effector functions such as complement-mediated, cell-mediated lysis and/or antibody-dependent cell cytotoxicity⁶ (ADCC), that can be of therapeutic interest. Various *in vitro* systems^{7,8} for the expression of recombinant full length mAb have been described. Transfection of eukaryotic expression vectors into immortalized B cells has been the most successful in terms of expression and functionality assuming that mAb are authentically processed, folded and post-translationally modified. Nevertheless, the level of expression in such a system is quite low. The expression of recombinant mAb in insect cells offers great advantages for the production of complex proteins with respect to stability, yield and assembling of functional glycosylation. Indeed, some functional mouse mAb have been successfully produced in the baculovirus–insect cell system.^{9–11} The aim of this work was the construction of a baculovirus for the expression and the secretion of complete

Received 5 September 1996; received 10 January 1997; accepted 16 January 1997.

Abbreviations: EBV, Epstein–Barr virus; mAb, monoclonal antibody; RBC, red blood cells; Rhesus, Rh; rmAb, recombinant monoclonal antibody.

Correspondence: Dr L. Edelman, Institut Pasteur, Laboratoire de Technologie Cellulaire, 28, rue du Dr Roux, 75724, Paris cédex 15 France.

functional human anti-Rhesus (Rh), IgG1 mAb derived from a parental IgM human mAb. This report describes the first anti-Rhesus recombinant antibody, expressed in insect cells with a cytolytic activity on Rh⁺ red blood cells.

MATERIALS AND METHODS

Obtaining the parental human line

Preparation of the Epstein-Barr virus (EBV)-transformed lymphocytes. A Rh⁻ volunteer blood donor (r/r) was injected with 5 ml of Rh⁺ erythrocytes (R1/r) and the peripheral lymphocytes (40 × 10⁶ cells) were isolated on a Ficoll-lymphoprep gradient (Eurobio, France) and transformed with 1 ml of culture supernatant of the EBV marmoset B96-8 cell line.

Serological investigation. Supernatants were analysed by agglutination tests using microplates (Costar, Bucks, UK) and a panel of Rh⁺ (R1/r) and Rh⁻ (r/r) papain-treated erythrocytes. Supernatants were tested with the standard Rh phenotype, and weak Rh phenotype using 2% suspension of native and papain-treated erythrocytes, in an agglutination test performed in test tubes. Determination of the antibody class was carried out using the enzyme-linked immunosorbent assay (ELISA) test.

Cloning of D7C2 cell line V λ and V H genes. First strand cDNA of light and heavy chains were produced from total RNA of D7C2 human cell line by reverse transcription using a poly dT primer. Polymerase chain reaction (PCR) amplification of V λ and V H regions was performed using VL_{FOR}/VL_{BACK} and VH_{FOR}/VH_{BACK} primers respectively. The VL_{FOR} and VH_{FOR} primers are consensus nucleotide sequences of the 5' coding ends of human V λ and V H 4 genes. The VL_{BACK} and VH_{BACK} primers are consensus nucleotide sequences of the 3' coding ends of V λ and V H genes. Each primer contains a restriction site for the subsequent cloning of the PCR products (Table 1).

The PCR products were cleaved with *SacI/XhoI* and *PstI/KpnI* respectively. The fragments were inserted in pBluescript (Stratagene, La Jolla, CA) and sequenced by the di-deoxy terminator procedure.

Construction of the recombinant baculovirus

Constructions of transfer vectors. PCR-amplified human V λ and V H rearranged sequences were subcloned in forced orientation into baculovirus transfer plasmids pBHUC λ and pBHUC γ 1 to yield transfer vectors pB λ D7C2 and pB γ 1D7C2 respectively (Fig. 1). The pBHUC λ plasmid contains the sequence for a mouse VH leader peptide in frame with a consensus sequence encoding the NH2 end of a human V κ

domain followed by the human C λ gene. These sequences are under the transcriptional control of the baculovirus polyhedrin promoter. The plasmid pBHUC γ 1 contains the sequence for the mouse leader peptide in frame with a consensus sequence encoding the NH2 end of a mouse VH domain, followed by the human C γ 1 chain cDNA. This construction is placed downstream of the baculovirus p10 promoter.¹²

Transfection and isolation of recombinant viruses. Transfections of *Spodoptera frugiperda* (Sf9) cells [American Type Culture Collection (ATCC) 358 CRL 1711] were performed using 500 ng of baculovirus DNA and 10 μ g of transfer vector. Viral and plasmid DNA were mixed with 40 μ l of DOTAP reagent (Boehringer, France) in 3 ml of TC100 medium (Gibco-BRL, Cergy-Pontoise, France) prior to being added to 4 × 10⁶ cells. After incubation at 28°C for 4 h, the transfection mix was replaced by 4 ml of fresh medium supplemented with 5% fetal calf serum (Gibco-BRL). The recombinant baculoviruses were plaque-purified from the supernatant of transfected cells after 5 days of incubation at 28°C. A two-step recombination procedure was carried out to construct a baculovirus expressing both L and H chains of the human recombinant mAb (rmAb) (Fig. 1). The first step consisted in cotransfecting cells with baculovirus AcMNPV-DNA¹³ and pB λ D7C2 transfer vector DNA to obtain a recombinant baculovirus expressing the L chain of the antibody. An occlusion-bodies negative (ob-) recombinant baculovirus expressing the L chain under the control of the polyhedrin promoter was isolated and called AcMNPV- λ D7C2. The second step was carried out using the AcMNPV- λ D7C2 DNA and pB γ 1-D7C2. The resulting recombinant Ac10HRh-33LRh was isolated by means of the presence of the heavy γ 1 chain in the supernatant of infected cells by solid-phase ELISA. Briefly, microtitre plates (NUNC, Strasbourg, France) were coated with an optimal concentration of anti-human immunoglobulin (Caltag Laboratories, San Francisco, CA). After washing and incubation of plates with phosphate-buffered saline (PBS) and 1% fetal calf serum, 50 μ l of supernatant of infected cells were added to wells. The rmAb was revealed by the biotinylated anti-human IgG antibodies (Caltag Laboratories), followed by incubation with alkaline phosphatase-conjugated streptavidin (Caltag Laboratories). The enzyme activity was revealed by the specific substrate *p*-nitrophenyl phosphate (Sigma Chemical Co, Saint Louis, MO) and optical density (OD) was read at 405 nm. A double recombinant baculovirus was subsequently plaque-purified and isolated. This virus expressed the L chain of R.D7C2 under the control of the polyhedrin promoter and the H chain of R.D7C2 under the control of the p10 promoter (Fig. 1).

Table 1. Primer sequences

Primer	Sequences (5' to 3')	Restriction site in the primer
VL FOR	CA (G/C) TCT GAGCTCAC (G/T)CAG	<i>SacI</i>
VL BACK	TTGAAGCTCGAGGGAGGGCGGAA	<i>XhoI</i>
VH FOR	GTCCAACCTGCAGCAGTGGGGCGCA GGACTGTTGAAGCCTTCGGAG ACCCTGTCCCTC	<i>PstI</i>
VH BACK	TGAGGAGACGGTGACCGTGGTACCTT GGC	<i>KpnI</i>

The restriction sites are underlined.

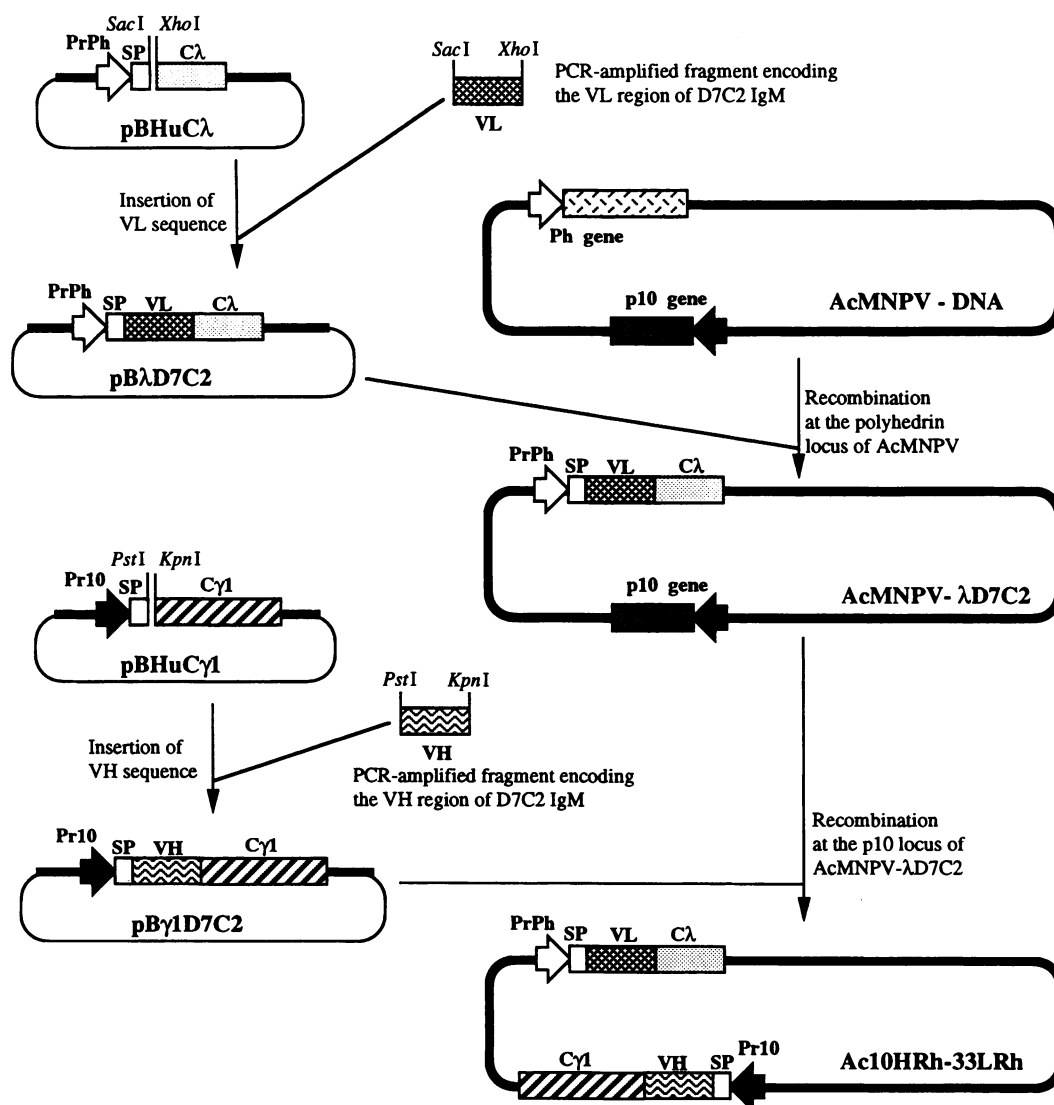

Figure 1. Schematic representation of the construction of Ac10HRh-33LRh double-recombinant baculovirus co-expressing heavy and light chain genes of recombinant D7C2 mAb. PCR-amplified sequence encoding VL region was inserted in pBHuC λ cassette vector to generate pB λ D7C2 plasmid, which was subsequently used to transfer the full length sequence encoding the recombinant light chain into AcMNPV polyhedrin locus (see the Materials and Methods). Genomic DNA of the resultant virus (AcMNPV- λ D7C2) was used in cotransfection with pB γ 1D7C2 transfer vector to replace p10 gene with the sequence coding for the γ 1 heavy chain of the recombinant D7C2 mAb, giving the Ac10HRh-33LRh virus. Plasmid pB γ 1D7C2 was generated by cloning a PCR-amplified fragment encoding the VH region of D7C2 mAb into *Pst*I–*Kpn*I sites of pBHuC γ 1 cassette vector. PrPh, polyhedrin promoter; Pr10, p10 promoter; SP, signal peptide encoding sequence; C λ , sequence coding for the human λ light chain constant domain; C γ 1, sequence coding for the human γ 1 heavy chain constant domain; Ph, polyhedrin. Draws are not to scale.

Production and analysis of recombinant antibody

Recombinant antibody production and purification. Supernatant of Sf9 cells (500 ml) infected with the recombinant baculovirus in a spinner (10^6 cells/ml) was harvested at 4 days post infection, and clarified by centrifugation at 1000 *g* for 5 min. The concentration of the antibody was estimated by the ELISA test using alkaline phosphate and was purified on a Protein A column (Gel Sepracor, Saclay, France).

Sodium dodecyl sulphate–polyacrylamide gel electrophoresis (SDS–PAGE) and Western blot analysis. Samples were analysed under reducing or non-reducing conditions on 10 or 13% SDS–polyacrylamide gel using the buffer system of Laemmli.¹⁴ Proteins were subsequently transferred into a nitrocellulose

membrane and incubated with rabbit anti-human C γ 1 and/or anti-human C λ antisera (Dakopatts, Dako, Trappes, France). Proteins were revealed with goat anti-rabbit alkaline phosphatase-conjugated immunoglobulin.

Deglycosylation of denatured and reduced recombinant antibody (2 μ g) was achieved with 0.15 unit *N*-Glycanase R (Genzyme) for 18 h at 37°.

The secreted human placental alkaline phosphatase (SeAP) used as control is *N*-glycosylated as a recombinant molecule in baculovirus system.¹⁵ Molecular weight of the reduced and alkylated polypeptides was assessed by SDS–PAGE. The gel was stained with Coomassie brilliant blue (Serva, St-Germain-en-Laye, France).

Biological activity of the recombinant R-D7C2 monoclonal antibody

The biological activity of the recombinant antibody was measured with respect to an irrelevant recombinant antibody (IgG1, κ) as a negative control, produced under the same conditions in insect cells.

Agglutination in test tube. Agglutination tests were performed with insect cell culture supernatants and a panel of papain-treated erythrocytes. A 50 μ l sample of supernatant and of 2% suspension of RBC were incubated for 45 min at 37°; agglutination was graded from + to +++ according to intensity of the reaction. Recombinant antibody titre was determined by incubating the supernatant with pooled R1/r papain-treated erythrocytes for 1 h at 37°.

Evaluation of agglutination tests in 1000 blood donors. One thousand normal blood donors with a common Rh phenotype were tested with rmAb in parallel with a monoclonal anti-D IgM (FAST, Sanofi Pasteur) on an automatic blood grouping SAMI distributor. The RBC pellet was diluted in a 2% bromelain solution (SIGMA 1 g/l) and incubated for 15 min at room temperature. The final suspension containing 25 μ l of bromelain RBC, 25 μ l of rmAb undiluted or anti-D fast 1/4 diluted in saline medium was centrifuged for 1 min. A reading was taken after resuspension.

Flow cytometry analysis of artificial mixtures. For flow cytometry 2 μ l of RBC at a 10% suspension were incubated with 50 μ l of rmAb (10 μ g/ml) or polyclonal antibody (10 μ g/ml) and 50 μ l of 30% bovine serum albumin. After 1 hr at 37°, cells were washed twice and incubated with 50 μ l of fluorescein isothiocyanate (FITC)-labelled rabbit anti-mouse IgG (Bio Atlantic, Nantes, France; diluted 1/100) and analysed with the cytofluorometer (FacScan; Becton Dickinson).

Antibody-dependent cellular cytotoxicity test (ADCC). The mononucleated layer of effector cells (lymphocytes) was obtained from a normal blood donor and incubated at 37° overnight in a plastic cell culture box containing DMEM and 1% fetal calf serum; non-adherent cells were collected and used in cytotoxicity tests (8×10^6 cells/ml).

Target cells (RBC) (20×10^6 cells) from R1/R1 and r/r donors (negative control) were papain-treated and incubated for 1 hr at 37° with 200 μ Ci of sodium chromate washed four times, and resuspended in 0.9% of NaCl.

ADCC tests were performed in triplicate and included the controls to measure spontaneous release of radioactivity without effectors. The maximum radioactive release was determined by adding distilled water (vol/vol) to the RBC; RBC cells were sensitized with either anti-D recombinant R-D7C2 or anti-D specific polyclonal anti-Rh antibodies (CNTS, Paris) or irrelevant recombinant antibody (IgG1 class) as a negative control. Each antibody was used at the concentration of 3.5 μ g/ml. Antibody titrations in PBS medium were performed as follows: 1/10, 1/35, 1/70 corresponding to 350, 100 and 50 ng/ml of IgG respectively.

Effector and target cells were placed in round-bottomed microplates; 50 μ l of the sodium chromate labelled red cell suspension (8×10^5 cells/ml) were placed in each well (at a lymphocyte to RBC ratio of 10:1); 50 μ l of each antibody were then added for comparative study and incubated for 18 h. The radioactivity was then determined in the supernatants and the specific lysis was calculated:

$$\frac{(\text{c.p.m. release in a test}) - (\text{c.p.m. spontaneous release})}{(\text{c.p.m. maximum release}) - (\text{c.p.m. spontaneous release})} \times 100 = \% \text{ of specific lysis}$$

RESULTS

Expression, assembly and secretion of the recombinant antibody

A recombinant baculovirus which directs the production of the R.D7C2 mAb was obtained. In this baculovirus, the cDNA encoding the human light λ chain is under the control of the very late polyhedrin promoter of AcMNPV, and the cDNA encoding the human heavy γ 1 chain is under the control of the very late p10 promoter of AcMNPV. Cell extracts and supernatants of insect cells infected with RmAb were analyzed 4 days post infection by Western blot (Fig. 2) and proteins were detected with a mix of anti-human $\text{C}\gamma$ 1 and anti-human $\text{C}\lambda$ antisera.

Reduced samples prepared from cells (Fig. 2, lane 3) and supernatants (lane 4) showed the same 26 000 MW (L chain) and 56 000 MW (H chain) bands migrating as did the two chains generated by reduction of a control human IgG1 (lane 1). The identity of the bands was confirmed by using anti-human λ chain or anti-human γ 1 chain antibodies alone (results not shown). Analysis in non-reducing conditions

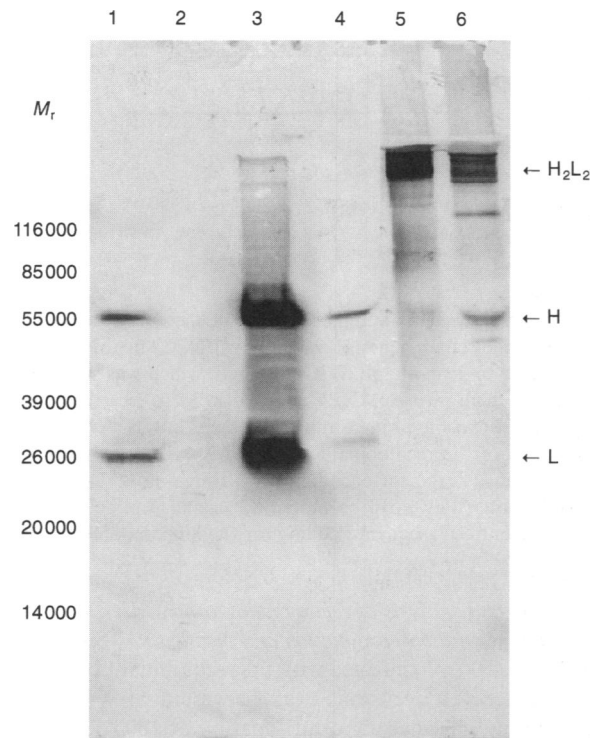

Figure 2. Western blot analysis for expression of the recombinant immunoglobulin light (L) and heavy (H) chains in cells infected with recombinant baculovirus. Lane 1, control human IgG1; lane 2, wild-type AcMNPV-infected cells; lane 3, recombinant baculovirus-infected cells; lane 4, culture supernatants from recombinant baculovirus-infected cells (lanes 1–4, reduced samples); lane 5, culture supernatant from recombinant baculovirus-infected cells; lane 6, control human IgG1 (lanes 5–6, non-reduced samples).

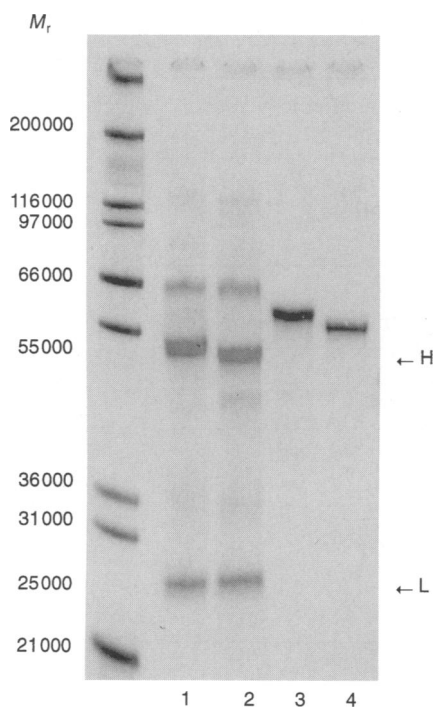

Figure 3. Analysis of the glycosylation of the recombinant antibody. Lane 1, rmAb (2 µg); lane 2, rmAb 2 µg + *N*-Glycanase; lane 3, SeAP 2 µg (control); lane 4, SeAP 2 µg + *N*-Glycanase (control). SeAP, secreted human placental alkaline phosphatase.

(Fig. 2, lane 5) showed that rmAb migrated as a high molecular weight complex identical in size to the control human IgG1 (lane 6). Separate detection with either anti-human λ chain or anti-human γ 1 chain antibodies demonstrated that R.D7C2 migrates with a molecular weight comparable with that of a complex composed of the two chains, as it was the case for the control mAb. This result demonstrates that R.D7C2 produced in insect cells was correctly assembled and secreted into the culture medium as a heterodimeric H2L2 immunoglobulin. The yield of secreted R.D7C2, measured by ELISA, was about 10 µg/ml.

Heavy chain glycosylation of the purified recombinant antibody was demonstrated by treatment with *N*-glycanase. The apparent molecular weight of the recombinant antibody heavy chain decreased after enzyme treatment, indicating that the antibody is in fact glycosylated (as did the SeAP used as control) (Fig. 3).

The Coomassie blue-stained gel also revealed a slight size difference of the glycosylated recombinant heavy chain as compared to the control. This result could reflect a high mannose type glycosylation pattern of the recombinant antibody. Such a glycosylation pattern has been previously described for insect cells.¹⁶

Biological activity of the recombinant antibody

The recombinant R.D7C2 was analysed for recognition and binding to erythrocytes carrying the Rh D surface antigen.

Agglutination tests showed that common Rh D⁺ cells were strongly agglutinated after papain treatment whereas Rh D⁻ cells were not (Table 2). With a reduced reactivity in compari-

Table 2. Agglutination tests of the parental cell line D7C2 and the recombinant antibody with common RBC

Papained RBC	Parental cell line D7C2		Recombinant cell line R.D7C2	
	Intensity	Titre	Intensity	Titre
Dccee	+++	128	+++	1/128
DCcee	+++	256	+++	1/128
DCCee	+++	64	+++	1/64
DccEE	+++	64	+++	1/64
ddccee	—	—	—	—
ddCcee	—	—	—	—

son with the parental antibody, fewer Du cells were recognized, 75% in a limited number of cases. On a panel of papain-treated RBC, the titre was 1/512.

It should be noted that the parental clone D7C2 was selected from its agglutination characteristics: intensity + + +, avidity 4 seconds, with Rh⁺ RBC (Table 2). In addition, 20/25 samples of Du red cells were agglutinated.

Study on 1000 blood donors did not show any discrepancy with the other anti-Rh D mAb test used in parallel. All the different Rh phenotypes were positive with proportions of: DCCee, 2021 (18.7%); DccEE, 213 (1.97%); DccEe, 1167 (10.8%); DCcEe, 1308 (12.1%); Dccee, 366 (3.38%); DCcee, 3787 (35.04%).

Flow cytometry analysis showed that the rmAb specifically bound to all Rh D⁺ red cells in artificial mixtures since Rh D⁺ cells were fluorescent whereas Rh D⁻ were not. In artificial whole blood containing 90% Rh D⁻ RBC in autologous plasma and 10% Rh D⁺ cells, 9.3% of cells were identified as Rh D⁺ by flow cytometry, whereas very close values were obtained with a polyclonal antibody or with an IgG anti-DmAb (Table 3). These data strongly suggest that *in vivo* the rmAb will specifically coat the Rh D⁺RBC.

The ADCC of recombinant antibody showed a percentage of 93% of lysis, compared to the polyclonal anti-Rh used in parallel which had a percentage of 76% at the similar concentration of 3.5 µg/ml. The percentage of the controls using an irrelevant recombinant IgG1 antibody was 0.3%. When Rh⁻ RBC were used, the percentage also remained negative (Table 4).

The subsequent study of titrations ADCC experiments showed that the percentages of lysis obtained with the rmAb were 56%, 37% and 30% for 350, 100 and 50 ng/ml of IgG respectively. Under the same conditions polyclonal antibodies gave 64%, 60% and 57% of lysis.

DISCUSSION

In order to produce a genetically engineered anti Rh⁻D human mAb in insect cells, we have designed a baculovirus which, after infection of the cells, directs the co-expression of the H and L chains of a human IgG1 and the secretion of the assembled IgG in the culture medium. For this purpose we have constructed two transfer plasmids carrying cassettes comprising the C γ 1 and C λ genes under the control of the baculovirus p10 and polyhedrin late strong promoters respect-

Table 3. Flow cytometry analysis of artificial mixtures of RhD⁻ (90%) RBC in autologous plasma and RhD⁺ (10%) RBC

Antibody	Specificity	Class	Concentration ($\mu\text{g/ml}$)	RhD ⁺ RBC
mAb NaTh52 -2G10	Anti-D	IgG1	10-20	11.5
rmAb D7C2	Anti-D	IgG1	10	9.3
Polyclonal antibody	Anti-D	IgG (serum)	10	7.5

Table 4. ADCC test using papain-treated Rh⁺ (R1/r) and Rh⁻ (r/r) red blood cells

	R1/r RBC % of specific lysis	r/r RBC % of specific lysis
Lymphocytes + RBC	0.65	0.75
Lymphocytes + RBC + irrelevant rmAb (IgG1, 3.5 $\mu\text{g/ml}$)	0	0
Lymphocytes + RBC + rmAb D7C2 (IgG1, 3.5 $\mu\text{g/ml}$)	93.3	0
Lymphocytes + RBC + polyclonal anti-D (3.5 $\mu\text{g/ml}$)	76.0	0.1

ively, and a murine signal leader provided for the secretion of the H and L chains.

The recombinant baculovirus was constructed using PCR cloned from variable regions of the human parental IgM-secreting cell line and used to direct the expression of engineered immunoglobulin sequences in insect cells. The human mAb produced, was correctly assembled, glycosylated and secreted in a functional form.

Human IgG1 has one glycosylation site in the CH2 domain of the C γ region, linked through asparagine-297. *N*-glycosylation is initiated by the addition of an oligosaccharide to the asparagine residue using the authentic carbohydrate acceptor sites to produce *N*-linked oligosaccharides.¹⁷ The oligosaccharides are involved in IgG stability, and C1q binding; aglycosylated IgG has been shown to lack several important biological functions, e.g. binding to Fc receptors on macrophages, activating complement, inducing ADCC. Insect cells have been shown to process and glycosylate foreign eukaryotic proteins.^{18,19}

However, insect cells cannot add branched oligosaccharides; these cells appear to lack or have low levels, of the necessary fructose, galactose and sialic acid transferases. Furthermore, they seem unable to process the core oligosaccharide²⁰ which has been shown to contain a high proportion of mannose residues.²¹

Using the baculovirus-insect cell expression system a few antibodies have been produced.^{11,22} In the past, expression of partial antibody fragments from *Escherichia coli* has led to the single chain antibody²³ or production of Fv fragments²⁴ and Fab molecules.^{25,26} In all cases, the amount of antibody secreted by *E. coli* is quite low, and there is no Fc region produced which would mediate ADCC. These incomplete molecules do not possess the biological functions associated with the constant domains.

The described rmAb, considering its *in vitro* activity (i.e. specific lysis), could be a therapeutic product. In the case of Rh⁻ D fetal maternal incompatibility, it might be used for the removal of fetal Rh⁺ RBC contaminating the maternal

blood. For a long time, human polyclonal anti Rh⁻ D has been used for such a purpose²⁷⁻²⁹ but due to the scarcity of these reagents, human mAb are urgently needed. The recombinant IgG1 R.D7C2 specifically binds to Rh D⁺ RBC in artificial mixtures and has proved to be a potent reagent to provoke lysis of target RBC. Further work is needed in order to analyse its efficacy as compared with other human IgG monoclonal antibodies^{30,31} and to determine if it can be used therapeutically in humans.³²

In vivo testing on chimpanzees has shown that human monoclonal anti-Rh antibodies effectively clear human Rh⁺ RBC.³³ Moreover, monoclonal anti-Rh antibodies (obtained after immortalization of lymphocytes by EBV) cause clearance of Rh⁺ RBC when injected into Rh⁻ volunteers.³⁴⁻³⁶

These results allow us to conclude that our recombinant anti-Rh antibody could be useful therapeutically. Furthermore, the baculovirus-insect cell expression system may be a more reliable product with regard to the contamination by infectious particles such as human immunodeficiency and hepatitis viruses.

ACKNOWLEDGMENTS

We would like to thank C. Préhaud, J.P. Bouvet and F. Godeau for helpful and discussions.

REFERENCES

- BRUGGEMANN M., WINTER G., WALDMANN H. & NEUBERGER M.S. (1989) The immunogenicity of chimeric antibodies. *J Exp Med* **170**, 2153.
- LEVY R. & MILLER R.A. (1983) Biological and clinical implications of lymphocyte hybridomas: tumor therapy with monoclonal antibodies. *Annu Rev Med* **34**, 107.
- MILLER R.A., OSEROFF A.R., STRATTE P.T. & LEVY R. (1983) Monoclonal antibody therapeutic trials in seven patients with T-cell lymphoma. *Blood* **62**, 988.
- BOULANE G.L., HOZUMI N. & SHULMAN M.J. (1984) Production of a functional chimaeric mouse/human antibody. *Nature* **312**, 643.

5. LO BUGLIO A.F., WHEELER R.H., TRANG J. *et al.* (1989) Mouse/human chimeric monoclonal antibody in man: kinetics and immune response. *Proc Natl Acad Sci USA* **86**, 4220.
6. BRUGGEMANN M., WILLIAMS G.T., BINDON C.I. *et al.* (1987) Comparison of the effector functions of human immunoglobulins using a matched set of chimeric antibodies. *J Exp Med* **166**, 1351.
7. OI V.T., MORRISON S.L., HERZENBERG L.A. & BERG P. (1983) Immunoglobulin gene expression in transformed lymphoid cells. *Proc Natl Acad Sci USA* **80**, 825.
8. RICE D. & BALTIMORE D. (1982) Regulated expression of an immunoglobulin k gene introduced into a mouse lymphoid cell line. *Proc Natl Acad Sci USA* **79**, 7862.
9. HASEMANN C.A. & CAPRA J.D. (1990) High-level production of a functional immunoglobulin heterodimer in a baculovirus expression system. *Proc Natl Acad Sci USA* **87**, 3942.
10. PUTLITZ J.Z., KUBASEK W.L., DUCHENE M., MARGET M., VON SPECHT B.U. & DOMDEY H. (1990) Antibody production in baculovirus-infected insect cells. *Biotechnology* **8**, 651.
11. NESBIT M., FU Z.F., McDONALD-SMITH J., STEPLEWSKI Z. & CURTIS P.J. (1992) Production of a functional monoclonal antibody recognizing human colorectal carcinoma cells from a baculovirus expression system. *J Immunol Methods* **151**, 201.
12. POUL M.-A., CERUTTI M., CHAABIHI H., DEVAUCHELLE G., KACZOREK M. & LEFRANC M.-P. (1995) Design of cassette baculovirus vectors for the production of therapeutic antibodies in insect cells. *Immunotechnology* **1**, 189.
13. CHAABIHI H., OGLIASTRO M.-H., MARTIN M., GIRAUD C., DEVAUCHELLE G. & CERUTTI M. (1993) Competition between baculovirus polyhedrin and p10 gene expression during infection of insect cells. *J Virol* **67**, 2664.
14. LAEMMLI U.K. & SMITH G.E. (1970) Cleavage of structural proteins during the assembly of the head of bacteriophage T4. *Nature* **227**, 680.
15. GODEAU F., SAUCIER C. & KOURILSKY P. (1992) Replication inhibition by nucleoside analogues of a recombinant *Autographa californica* multicapsid nuclear polyhedrosis virus harboring the herpes thymidine kinase gene driven by the IE-1(0) promoter: a new way to select recombinant baculoviruses. *Nucleic Acids Res* **20**, 6239.
16. BUTTERS T.D., HUGHES R.C. & VISCHER P. (1981) Steps in the biosynthesis of mosquito cell membrane glycoproteins and the effects of tunicamycin. *Biochem Biophys Acta* **640**, 672.
17. JARVIS D.L. & SUMMERS M.D. (1989) Glycosylation and secretion of human tissue plasminogen activator in recombinant virus-infected cells. *Mol Cell Biol* **9**, 214.
18. SMITH G.E., SUMMERS M.D. & FRASER M.J. (1983) Production of human beta interferon in insect cells infected with a baculovirus expression vector. *Mol Cell Biol* **3**, 2156.
19. SMITH G.E., JU G., ERICSON B.L. *et al.* (1985) Modification and secretion of human interleukin 2 produced in insect cells by a baculovirus expression vector. *Proc Natl Acad Sci USA* **82**, 8404.
20. DAVIDSON D.J., FRASER M.J. & CASTELLINO F.J. (1990) Oligosaccharide processing in the expression of human plasminogen cDNA by lepidopteran insect (*Spodoptera frugiperda*) cells. *Biochemistry* **29**, 5584.
21. KURODA K., GEYER H., GEYER R., DOERFLER W. & KLENK H.D. (1990) The oligosaccharides of influenza virus hemagglutinin expressed in insect cells by a baculovirus. *Virology* **174**, 418.
22. CARAYANNOPOULOS L., MAX E.E. & CAPRA J.D. (1994) Recombinant human IgA expressed in insect cells. *Proc Natl Acad Sci USA* **91**, 8348.
23. BIRD R.E., HARDMAN K.D., JACOBSON J.W. *et al.* (1988) Single-chain antigen-binding proteins. *Science* **242**, 423.
24. MARKS J.D., OUWEHAND W.H., BYE J.M. *et al.* (1993) Human antibody fragments specific for human blood group antigens from a phage display library. *Biotechnology* **11**, 1145.
25. DZIEGIEL M., NIELSEN L.K., ANDERSEN P.S., BLANCHER A., DICKMEISS E. & ENGBERG J. (1995) Phage display used for gene cloning of human recombinant antibody against the erythrocyte surface antigen Rhesus D. *J Immunol Meth* **182**, 7.
26. WILLIAMSON R.A., PERSON M.A.A. & BURTON D.R. (1991) Expression of a human monoclonal anti-(rhesus D) Fab fragment in *Escherichia coli* with the use of bacteriophage λ vectors. *Biochem J* **277**, 561.
27. BOWMAN J.M. (1978) Suppression of Rh immunization. *Obstet Gynecol* **52**, 385.
28. DAVEY M.G. & ZIPURSKY A. (1979) McMaster conference on prevention of Rh immunization. *Vox Sang* **36**, 50.
29. ENGELFRIET C.P. (1992) The immune destruction of red blood cells. *Transf Med* **2**, 1.
30. THOMPSON K.M., MELAMED M.D., EAGLE K. *et al.* (1986) Production of human monoclonal IgG and IgM antibodies with anti-D (Rhesus) specificity using heterohybridomas. *Immunology* **58**, 157.
31. BRON D., FEINBERG M.B., TENG N.N. & KAPLAN H.S. (1984) Production of human monoclonal IgG antibodies against Rhesus (D) antigen. *Proc Natl Acad Sci USA* **81**, 3214.
32. ROUGER P. & GOOSSENS D. (1990) Human monoclonal antibodies against human red blood cells. In: *Therapeutic Monoclonal Antibodies*, (eds A.K. Borrebaeck & J.W. Larrick), Chapter 17, pp. 263–286. McGraw-Hill, New York.
33. BLANCHER A., SOCHA W.W., ROUBINET F. *et al.* (1993) Human monoclonal anti-D-induced clearance of human D-positive red cells in a chimpanzee model. *Vox Sang* **65**, 47.
34. THOMSON A., CONTRERAS M., GORICK B., KUMPEL B., CHAPMAN G. & DAWES B. (1990) Clearance of Rh D-positive red cells with monoclonal anti-D. *Lancet* **336**, 114.
35. GOODRICK J., KUMPEL B., PAMPHILON D.H., FRASER I.D., CHAPMAN G.E. & DAWES B. (1994) Plasma half-lives and bioavailability of human monoclonal Rh D antibodies BRAD-3 and BRAD-5 following intramuscular infection into Rh D negative volunteers. *Clin Exp Immunol* **98**, 17.
36. KUMPEL B.M., GOODRICK M.J., PAMPHILON D.H. *et al.* (1995) Human Rh D monoclonal antibodies (BRAD-3 and BRAD-5) cause accelerated clearance of Rh D⁺ red blood cells and suppression of Rh D immunization in Rh D⁻ volunteers. *Blood* **86**, 1701.