

THE NEURAL MECHANISM OF BINOCULAR DEPTH DISCRIMINATION

BY H. B. BARLOW, C. BLAKEMORE* AND J. D. PETTIGREW†

*From the Neurosensory Laboratory, School of Optometry,
University of California, Berkeley, California 94720, U.S.A.*

(Received 17 April 1967)

SUMMARY

1. Binocularly driven units were investigated in the cat's primary visual cortex.
2. It was found that a stimulus located correctly in the visual fields of both eyes was more effective in driving the units than a monocular stimulus, and much more effective than a binocular stimulus which was correctly positioned in only one eye: the response to the correctly located image in one eye is vetoed if the image is incorrectly located in the other eye.
3. The vertical and horizontal disparities of the paired retinal images that yielded the maximum response were measured in 87 units from seven cats: the range of horizontal disparities was 6.6° , of vertical disparities 2.2° .
4. With fixed convergence, different units will be optimally excited by objects lying at different distances. This may be the basic mechanism underlying depth discrimination in the cat.

INTRODUCTION

The image formed by a single eye is a two-dimensional projection of the three-dimensional world which entirely lacks representation of those distances in the three-dimensional world that are possibly of greatest survival value to an animal, namely the distances of the external objects from the eye. It is true that the third dimension of apparent depth can be added to the visual image of a single eye by using a number of indirect cues, such as the angular subtense of an object of known size, motion parallax, accommodative effort, and the obscuration of distant objects by nearer ones. However, these cues can only be utilized in special circumstances, and most of them require rather complex image-processing. In animals where the visual fields of the two eyes overlap the situation becomes much more favourable, for between them the different projections

* Harkness Fellow, 1965-67.

† Present address: Department of Physiology, University of Sydney, Australia.

on the two retinae now contain much more direct cues to the distances of the features of the image. Wheatstone (1838) demonstrated that these cues from binocular parallax could be used and this ability has been the subject of the extensive psychophysical investigations described by Ogle (in Davson, 1962).

One can distinguish two important steps that must be taken in order to employ these cues. The first is the selection of those parts of the two images that belong to each other in the sense that they are images of the same feature in three-dimensional space. The second is the assessment of the small displacements in the relative positions of these paired parts that result from binocular parallax and provide the cue to depth. This communication describes the possible neural mechanism whereby these two operations are performed in the cat's brain. A suggestion made by Pettigrew (1965) is supported, and further evidence will be found in other papers (Nikara, Bishop & Pettigrew, 1967, and Pettigrew, Nikara & Bishop, 1967*a, b*).

Vertical and horizontal disparities. In order to facilitate discussion of the displacements caused by parallax it is customary to take one retinal locus as a reference point, and for this the centre of each fovea in man, or area centralis in the cat, is naturally chosen. The position of a small part of the image in the right eye is defined by the angles from this reference point, H_R° measured horizontally, and V_R° measured vertically, preferably using the co-ordinate system proposed by Bishop, Kozak & Vakkur (1962). Now the position, H_L° , V_L° , of the paired counterpart in the left eye is found, and the *horizontal disparity* is defined as the difference between H_R° and H_L° , the *vertical disparity* as the difference between V_R° and V_L° . If one imagines a cat with the area centralis of each eye trained exactly on some point in space, then the images from all features lying on the circle through this point and the two anterior nodal points of the eyes will, by definition, have zero horizontal disparity. In studies on human binocular vision this is called the Vieth-Müller Circle. Points on the images from a feature lying inside this circle will have what is termed *convergent or crossed disparity*: points further away will have *divergent or uncrossed disparity*. Vertical disparities will occur because of slight differences in elevation of the eyes, and also because the linear magnification for the two eyes can be significantly different for objects lying at a distance which is only a few multiples of the interocular separation. However, the range of vertical disparities for features lying at reasonable viewing distances is much less than the range of horizontal disparities.

Anatomy and physiology. Isaac Newton was the first to propose partial decussation of the optic nerve fibres in binocular mammals (Polyak, 1957, reviews the early investigations). The optic tract of one side receives

information from the contralateral visual hemi-fields of both eyes. Although neurones from the two retinae lie near each other at the relay in the lateral geniculate nucleus, there is apparently little interaction in the primary visual pathway until the cortex is reached, for single neurones with a binocular input are rarely found at the geniculate (Bishop, Burke, Davis & Hayhow, 1958), whereas the majority of cells in the striate cortex can be binocularly driven. Hubel & Wiesel (1962) have described how cortical neurones respond only to the appropriate specific stimulus or trigger feature. Diffuse light or darkness will be ineffective, whereas a moving dark bar, bright slit, or edge, if correctly orientated, will cause a neurone to respond vigorously. Any stimulus will only cause a response in the small fraction of neurones that are appropriately 'tuned', i.e. those which respond to the right trigger feature, at the right orientation and position.

Now one can see that this might provide the basis for performing the first of the two operations postulated above, namely the identification of the parts of the two images corresponding to a single feature in object space. Clearly the number of identical trigger features in a small part of the monocular image is likely to be low: hence similar features, lying in the same approximate region of the image in each eye, can safely be assumed to belong to the same object. For example, a black line of a particular orientation in one image should be associated with the black line of the same orientation at the most nearly corresponding position in the other image because both are likely to be images of the same object.

Hubel & Wiesel (1962) said that the receptive field and appropriate stimulus for a cortical neurone was the same for each eye, and that the inputs from the two eyes summated when the two stimuli were correctly located. They thought that the receptive fields always lay in corresponding regions in the two retinae—presumably at zero disparity—but variations in disparity might have been obscured by residual eye movements in their preparation. We therefore thought it possible that different cortical neurones might require different horizontal disparities for optimal response: the trigger feature might have to lie at a specific distance from the cat and this distance might be different in different neurones, even with an unvarying convergence position of the eyes. If that were so, then these cortical neurones would be performing both of the operations required for binocular stereopsis. A particular neurone would respond optimally to only one of a variety of features (dark bar, light slit or edge) over only a fraction of the whole range of possible orientations, and over only a fraction of the possible range of distances. It would certainly require a very large number of neurones to cover the full range of possible stimulus features not only in variety and orientation, but also in position

and depth. However, since there is in fact an enormous number of neurones in the primary visual cortex compared with the number of incoming fibres, the idea cannot be rejected on this score.

To test this conjecture we need to find out first if the stimulus must have a specific disparity to excite a particular neurone, and if excitation with different disparities results in a substantially lower response. Qualitative evidence for this is provided in Fig. 1, and quantitative evidence is given in another paper (Pettigrew *et al.* 1967*b*). Secondly, we must find out if there exists, from neurone to neurone, a variation in the horizontal disparity required for optimal stimulation. Without such variation it might be held that binocular facilitation, such as is shown in Fig. 1, serves simply to improve the signal/noise ratio. But, if there exists variation of optimum horizontal disparity, then it follows that objects at different distances will optimally excite different neurones; consequently the neurones that respond can give cues to the depths of the features activating them. The aim of this investigation was to determine whether the binocular receptive fields of single cortical neurones all have the same disparity, or whether there is variation from neurone to neurone.

METHODS

We recorded the action potentials of single neurones in the primary visual cortex of adult cats, using methods that are already well established. The animal's head was firmly held in a stereotaxic frame with the horizontal Horsley-Clark plane tilted so that the visual axes were approximately horizontal. The animal was anaesthetized with 80 % nitrous oxide and 20 % oxygen, paralysed by continuous infusion of a relaxant mixture described below, artificially respired, and maintained thermostatically at 36° C. The characterization of each neural unit took 1-6 hr, and it was desirable to study as many as possible in each preparation. Long survival was therefore important for the success of this experiment, and with the methods employed good units could be obtained over a period as long as 6 days.

It is clear that eye movements would hopelessly mar the results and special precautions were taken to prevent them. First, a mixture of gallamine triethiodide (Flaxedil) at 5 mg/kg.hr with d-tubocurarine at 0.5 mg/kg.hr was infused continuously; higher dosages of curare often reduce arterial blood pressure by more than 20 mm Hg, and the life expectancy is drastically reduced. Eye-movements were found to be about 6 min of arc/hour (Rodieck, Pettigrew, Bishop & Nikara, 1967), but since this was still enough to be troublesome, the eyes were held mechanically by stretching and drying the conjunctivæ on metal rings attached to flexible arms (Fleximount tool holders) which could be locked in any position. In addition an open pneumothorax was made and cervical sympathectomy performed. Slipping of the contact lenses or correcting lenses can cause apparent image movements, and this was carefully prevented.

In order to test the adequacy of these precautions the optic disks were viewed ophthalmoscopically through transparent extensions of the tangent screen (see below), and their projections were carefully plotted several times during each experiment. In early experiments movements were observed, but when the above precautions were taken these projections did not change position perceptibly. Also, no change in the position of the borders of the tiniest receptive fields could be detected during the 1-6 hr of study.

When the eyes are fixed to rings one can no longer directly use the method developed in Sydney, based on the results of Bishop *et al.* (1962), to infer the approximate positions of the visual axes from the separation of the blind spot projections in the relaxed cat. Therefore the optic disks were always plotted, in the manner described above, before the eyes were manipulated, and the approximate horizontal distances from the blind spots to the visual axes were calculated, so that this information could be used to estimate the projections of the *areae centrales* after the eye positions had been changed.

It was also necessary to measure the torsion of the eyes caused by the relaxant and by fixing to the rings. This was estimated in two ways: (1) photographs of the slit-like entrance pupils were made in the unrestrained cat and after attachment of the eyes to rings. (2) In the majority of centrally located units the receptive field axis orientation could be accurately determined for each eye; the mean difference between them was attributed to torsion. These two estimates agreed well with each other in each cat. Similarly an approximate estimate of the difference in elevation of the two eyes could be made from the heights of the blind spot projections.

Special care was taken to preserve good optics: the corneae were covered with contact lenses, the pupils were dilated with phenylephrine (Neosynephrine) and atropine, 3 mm artificial pupils were used, and we applied the appropriate spherical refractive correction, establishing this by retinoscopy and direct ophthalmoscopy.

To provide the visual stimuli an overhead projector cast an image from behind on to a translucent tangent screen placed 114 cm from the eyes. A 45° Perspex (lucite) reflector produced an identical image on a horizontal board. Receptive fields were plotted on paper sheets positioned accurately on this board. A wide variety of visual stimuli could be produced by cutting or punching card masks and moving them by hand over the stage of the projector. As seen by the cat the luminance of the bright parts of these stimuli was about 500 cd/m², the dim background about 50 cd/m².

Because of the interocular separation and divergence of the visual axes the receptive fields were always well separated on the tangent screen, and it was easy to explore each separately: to exclude one eye completely an occluder was placed in front of it.

The current experiments did not extend beyond 15° eccentricity, and the majority of receptive fields were between 5° and 10°. This had the advantage of simplifying the calculations by making it permissible to assess disparities solely in terms of linear separations on the tangent screen. The errors caused by this simplification were calculated for the unit with the greatest eccentricity, and were found to be negligible.

RESULTS

Preliminary experiments taught us whereabouts in the cortex to place the electrode in order to record from neurones in the part of area 17 receiving its input from the central region of the visual field. The evidence that we were not recording in area 18, which lies next to 17, is as follows: (a) we inserted the electrode in area 17 according to the maps of Otsuka & Hassler (1962) and Hubel & Wiesel (1965): (b) we recorded a majority of units which, in most respects, fit Hubel & Wiesel's description of 'simple' cells: (c) if we moved laterally we obtained units which had much more complex properties: (d) if we moved medially we obtained units whose receptive fields lay more peripherally in the contralateral field of vision. There can therefore be little doubt that we were recording in the primary visual cortex.

We searched for the receptive fields by moving thin black bars, thin white slits, or black-white edges, of various orientations through the visual field. We found only minor divergences from Hubel & Wiesel's description (1962) of the units found in area 17. Out of 137 units 112 could be binocularly driven, although only 87 of these were plotted reliably enough to analyse the disparities. When a unit was found each eye was first studied independently. The axis orientation was established and two lines were marked parallel to this axis, marking the beginning and end of the response to a moving slit, bar, or edge, whichever was the most effective. These two lines form the primary borders of the plot. Lateral borders were determined by shifting laterally the continuously oscillating stimulus, maintaining the axis of orientation, until the end of the target had moved out of the field and no constant response could be elicited. This procedure was performed on both sides, and the resultant rectangular area we have called the *minimum response field*: regions outside this area affect the neurone but the influences are either subthreshold, or inhibitory and hence difficult to detect against a slow maintained discharge. Minimum response fields plotted in this way varied greatly in size, the smallest being about $3 \text{ min} \times 5 \text{ min}$, the largest about $6.5^\circ \times 6.5^\circ$. The fields for the two eyes were not necessarily the same size, the dominant eye tending to have the larger field. For reasons given below we think these minimum response fields give an approximate guide to the centres of the retinal areas which connect to a cortical neurone, but they do not by any means indicate the full extent of these areas. However, the plots were quite reproducible; repeat determinations indicated that the primary borders could be placed with an accuracy of 5–15 min, the lateral borders about 10–20 min. Reproducibility varied greatly from unit to unit.

For testing the hypothesis we need to know the positions of the stimulus for each eye where maximal binocular facilitation of the response is obtained. The centres of the minimum response fields provide a useful guide to these positions, but maximal facilitation was often obtained when the stimuli were not exactly centred on the minimum response fields, and, in a few of the smaller fields, the optimal position actually lay outside the monocular plot (for an example see Fig. 1 below). For this reason, when a minimum response field had been plotted for each eye, binocular interaction was examined by simultaneously stimulating the eyes with a pair of slits, bars, or edges, of the appropriate orientation, moved in synchrony. This is illustrated in Fig. 1. Owing to the divergence of the visual axes in our preparation the two minimum response fields lay several inches apart on the tangent screen, and the synchronously moving targets initially were separated by about the same amount. Variation of this separation varies the horizontal disparity of the binocular excitation; this

corresponds to a change in depth of a single target when the visual axes are directed towards some fixed point, as they would be in an unanesthetized cat with normal muscular tonus. At some critical separation of the stimuli a maximum facilitation of the response was noted (see Fig. 1), and the positions of these optimally separated targets were marked with a line on their respective monocular response fields at the peak of the binocular response, judged by ear. The point on this line where the normal would pass through the centre of the monocular minimum response field was called the *binocular centre*, and our analysis has been performed on these positions. The average distance of the binocular centre from the centre of the minimum response field was 12 min in the 87 units (174 fields), and in fourteen of the smaller minimum response fields it actually lay just outside the monocular plot.

Figure 2 shows the minimum response fields of all the binocularly driven units studied in one cat. The fields are each numbered, and appear as rectangles of varying size and orientation in two groups, one for the right eye and one for the left. In, or near, each rectangle is a black dot, representing the binocular centre. These are reproduced as they appeared on the tangent screen facing the cat; the next problem is how to calculate the disparities.

Data reduction. Ideally one would like to mark the exact position of the area centralis of each eye on Fig. 2, together with the true verticals and horizontals for the eyes in their normal positions, with no torsion. It would then be a simple matter to measure the position of each field in each eye in terms of azimuth and elevation, and obtain the horizontal and vertical disparities by taking the differences. Unfortunately it is extremely difficult to determine the position of the area centralis in the cat: it cannot be accurately located ophthalmoscopically, and we have made estimates based on the separation of the optic disks in the relaxed cat, using methods developed in P. O. Bishop's laboratory. However, the primary question we are trying to answer is not the absolute disparity of a single neurone, but whether the disparities are all the same. This question can be answered if many neurones are investigated in a single preparation, where the projections of the area centralis of each eye, wherever they may be, are always in the same place. For this reason we are not too upset by large errors in determining the position of the area centralis.

Figure 3 shows the result of adjusting the positions of the response fields in Fig. 2 by three operations. First, the response fields were swung around the area centralis to correct for the estimated torsion of each eye; the figure shows that the left eye had more torsion (see Methods). Next the right fields were lowered to correct for the greater elevation of the right area centralis compared with the left. Finally, the linear displacements

required to superimpose all the binocular centres of the left eye were measured, and these same displacements were applied to each of the corresponding right eye centres. The result is of course to make all the left eye centres coincide, and if the disparities were always equal the right eye

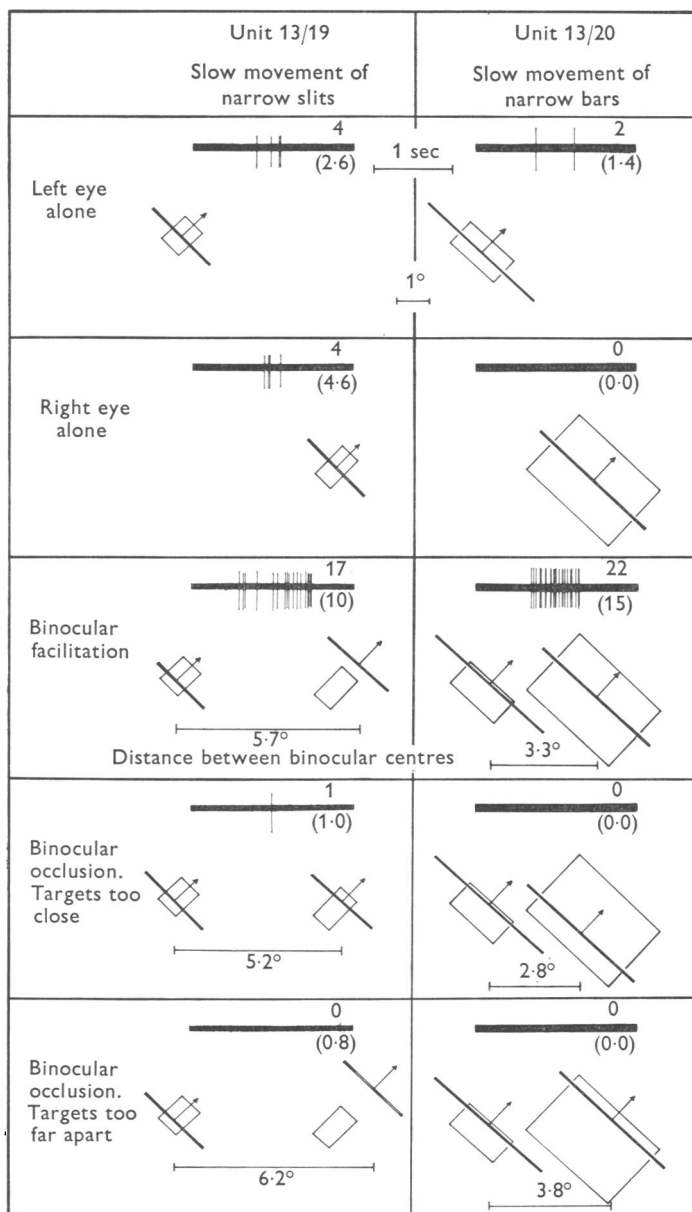

Fig. 1. For legend see opposite page.

centres would also coincide. It is abundantly clear that they do not, for these centres lie in an oval with 6.3° horizontal spread and 2° vertical spread. The 3 to 1 difference is worth emphasizing, for if the spread of disparities arose as a result of accumulated errors of our original estimates and the various corrections, there is no reason why the horizontal errors should so greatly exceed the vertical.

In Fig. 3 the direction of motion giving the greatest response is also indicated by an arrow; half length arrows signify bi-directional units. It might be thought that the disparities would be associated with their directional specificity, either because of errors associated with time lags, or possibly for some functional reason, but there is no evidence for this.

In six other cats sufficient neurones were isolated to estimate the horizontal and vertical spread of disparities. The total range and the unbiased estimate of standard deviation are used as measures of this spread in Table 1 which shows the results for all seven cats. There is no doubt that the spread of horizontal disparities greatly exceeds the spread of vertical disparities.

Figures 4 and 5 show the information from seven preparations combined in two different ways. In the histograms of Fig. 4 we have measured all disparities using the estimated positions of the two areae centrales as the reference points of zero disparity. Note the asymmetry of the distribution of horizontal disparity, with more convergent than divergent disparity. Note also that the ranges (2.8° vertical disparity and 7.9° horizontal disparity) exceed those of individual cats, probably because the error in locating the areae centrales is extending them. In Fig. 5 the

Legend to Fig. 1.

Fig. 1. Binocular interactions showing that facilitatory responses occur at different disparities in two cortical neurones from the same cat. The units were studied consecutively, their receptive fields lay close together in the visual field, and their axis orientations were the same. For each unit five stimulus conditions are illustrated—monocular stimulation for each eye alone, and three examples of binocular stimulation. Each box contains a sample record (retouched for reproduction, positive deflection downward) with the number of spikes in that sample and the average number for five repetitions in parentheses. The positions of the stimuli and the minimum response fields on the tangent screen are illustrated diagrammatically. Eye torsion and elevation have been corrected, but no correction has been made for the divergence of the visual axes or the separation of the two eyes. The projections of the areae centrales would be separated by about 6.4° in this diagram. Minimum response fields were plotted with a bright slit for both units, but binocular facilitation showed up better with a dark bar for unit 13/20, and these responses were chosen for this illustration. Slits and bars were 3 min of arc wide and several degrees long. Optimum facilitation occurs at 5.7° separation of targets for unit 13/19, 3.3° separation for unit 13/20. These were estimated to be equivalent to 0.7° and 3.1° of convergent disparity.

results from separate preparations have been combined by superimposing the means of the individual histograms on the assumption that the mean vertical disparity is zero, and the mean horizontal disparity is the same in all preparations; for this figure it was assumed to be zero. As would be expected the spread is reduced, and becomes comparable with that of individual cats. In this figure we have also indicated the disparities of the estimated positions of the areae centrales of each cat, having defined

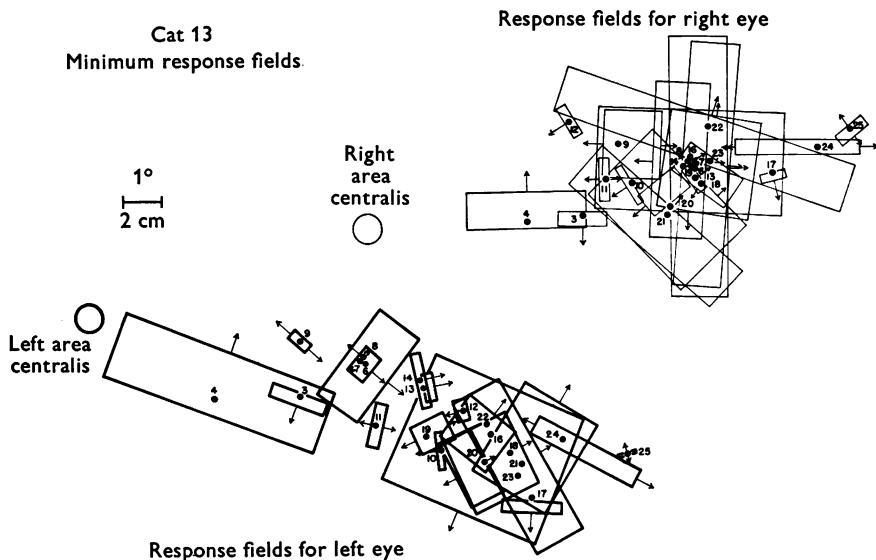

Fig. 2. A reconstruction of the minimum response fields for all the binocularly driven units studied in cat 13 as they appeared on the screen. For each unit there are two rectangular plots, not necessarily of the same size, with arrows to indicate the preferred directions of movement. Directionally-selective units have one arrow, bi-directional units two. The estimated projections of the areae centrales are shown and it is apparent that the visual axes are divergent. All the units in this cat were recorded from the left hemisphere and hence the minimum response fields occupy the contralateral visual hemi-field. The intorsion of the eyes, much more in the left than in the right, is reflected in the tilting of the two arrays of fields with respect to each other. In or near each minimum response field is the number of the unit and a dot representing the position of the binocular centre for that eye.

the mean separation of binocular centres as zero disparity. The scatter of apparent disparities of the areae centrales is probably caused by errors of the procedure for estimating their positions, and we therefore believe that the histograms in Fig. 5 give a better representation of the actual disparities of cortical neurones than Fig. 4.

One must bear in mind the possibility that the mean disparity of cortical neurones varies with the eccentricity of their receptive fields in the visual

field. Our data are not adequate to decide if there is a constant association between mean disparity and eccentricity, but there is certainly a big spread of disparities at all eccentricities. In Fig. 6 the data from cat 13 are

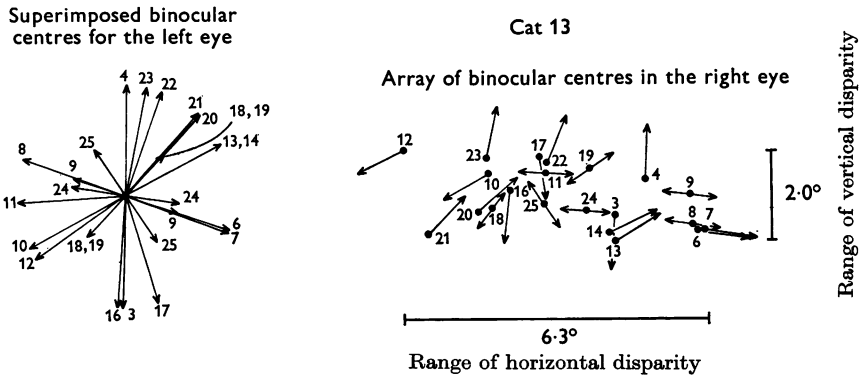

Fig. 3. Range of horizontal and vertical disparities of twenty-one cortical neurones in one cat. The positions of the receptive field centres for maximum binocular facilitation were determined on the tangent screen, and then shifted to correct for torsion and the difference in elevation of the two eyes. The directions and amounts of movement required to superimpose all the binocular centres of the receptive fields in the left eye were measured, and each right eye field was then shifted in a parallel direction by the same amount as its left eye counterpart. Arrows show the directional selectivity of the units, half length arrows indicating bi-directional responses. In this figure the dots at the tails of the arrows show the shifted positions of the binocular centres: they are superimposed in the left eye, and the scatter of the right eye dots shows the distribution of disparities.

TABLE 1. Spread of vertical and horizontal disparities in seven individual cats and results pooled by two alternative methods

Cat no.	Horizontal disparity		Vertical disparity		No. of units studied
	Total range in degrees	Standard deviation in degrees	Total range in degrees	Standard deviation in degrees	
6	2.4	1.2	0.4	0.21	3
7	2.9	0.85	1.6	0.45	9
8	4.2	0.94	1.5	0.38	19
9	4.7	1.5	2.2	0.75	12
10	3.9	1.4	0.9	0.36	6
11	5.7	1.6	1.1	0.34	17
13	6.3	1.9	2.0	0.62	21
Pooled: areae centrales superimposed	7.9	1.8	2.8	0.55	87
Pooled: individual means superimposed	6.6	1.5	2.2	0.51	87

displayed to show at what distance and horizontal position in space a stimulus should be applied to excite optimally each neurone, if the areae centrales are converged on a point 50 cm from the eyes.

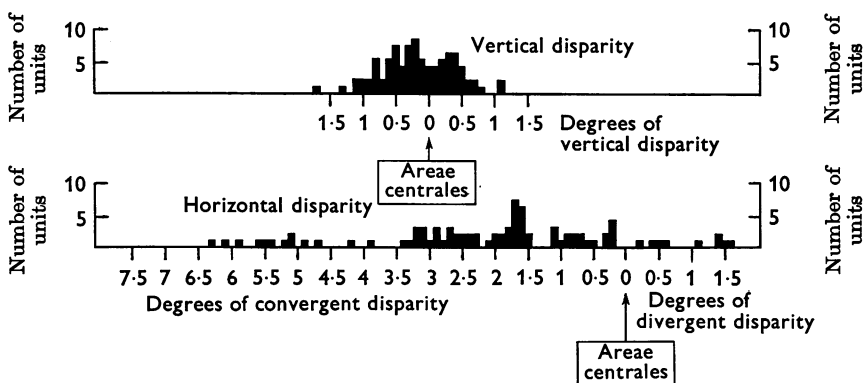

Fig. 4. Histograms of horizontal and vertical disparities of the binocular centres for 87 units in seven cats. The positions of the two areae centrales were estimated in each cat, and their vertical and horizontal separations were assigned zero disparity in that cat. If the horizontal angular separation of the binocular centres was less than the areae centrales, the unit had convergent disparity; if greater, the unit had divergent disparity. These units would be optimally stimulated by objects lying closer than, or beyond, the fixation point in the normal cat.

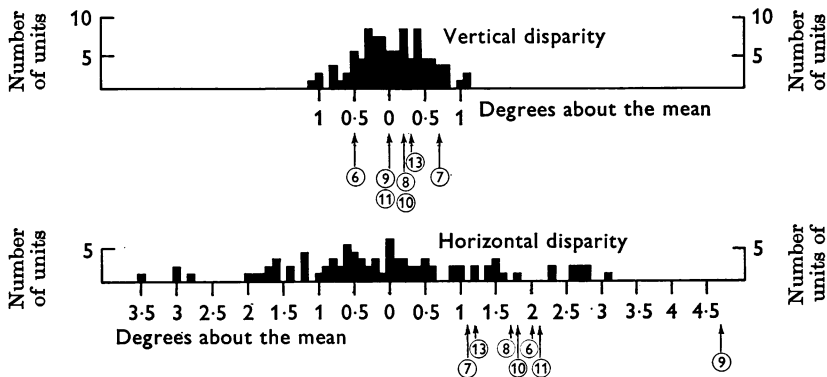

Fig. 5. Histograms of horizontal and vertical disparities with means superimposed. In Fig. 4 the results from different cats were combined by measuring disparities relative to the areae centrales, but since the estimate of area centralis position is subject to considerable error, Fig. 4 may indicate too wide a spread of disparities. In this figure the mean vertical and horizontal angular separations of the binocular centres for each cat have been assigned zero disparity and these reference points have been superimposed. This gives a more conservative estimate of the range of disparities than Fig. 4. Below the scale of each histogram are seven circles containing the identifying numbers of the cats. Arrows from these circles indicate the horizontal and vertical separations of the estimated areae centrales with respect to the mean disparities of the binocular centres. Much of the dispersion of these estimates is likely to be caused by errors in estimating the position of the area centralis.

DISCUSSION

Figure 1 shows that the retinal images of a trigger feature must be correctly placed in both eyes to evoke the most vigorous response, and that incorrect positioning, equivalent to a disparity in the retinal images inappropriate for that particular neurone, results in a much smaller response. Furthermore, the results shown in Figs. 3-6 prove that different

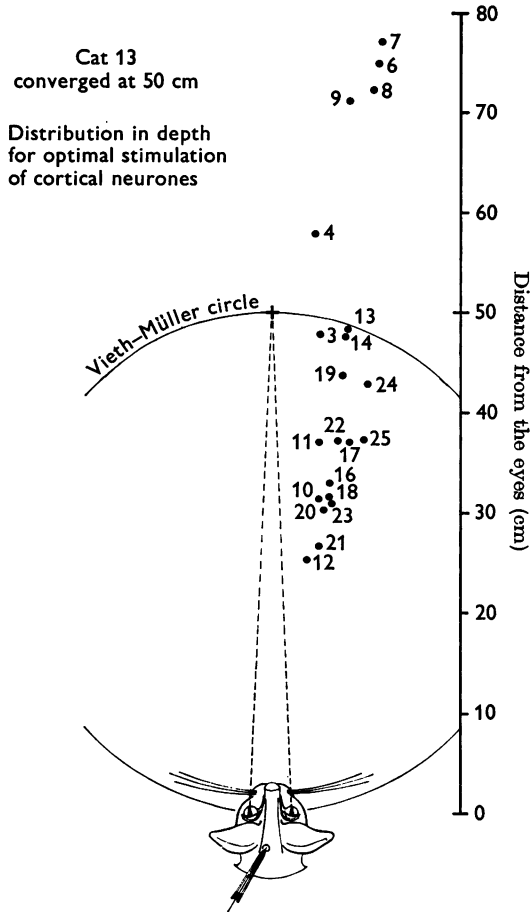

Fig. 6. Distribution in depth of positions for optimal stimulation of the units studied in cat 13. After the corrections for torsion and elevation had been made the array of binocular centres in both eyes was moved until the estimated visual axes were converged on a point 50 cm from the eyes. Each numbered dot shows the horizontal position and depth in space an object would have to occupy in order for its retinal images to fall on the binocular centres in the two eyes for that unit. These points are, then, the optimal positions in space, projected on to the horizontal plane, for the trigger features of the cortical cells.

neurons require different disparities. It follows that, with fixed convergence, objects at different distances will excite different neurons. This provides a plausible basis for binocular depth discrimination and stereopsis, but of course there remains a lot to discover about how this depth information, segregated in different primary cortical cells, is subsequently sorted out by higher order visual neurons.

The 7° spread of horizontal disparities is very large compared with the disparity threshold required for stereopsis—only about 10 sec in man. Few estimates have been made of the upper limit for obtaining stereopsis, but Rashbass & Westheimer (1961) obtained definite convergent or divergent human eye movements for up to 5° of convergent or divergent disparity. Obviously, such movements require, at some stage, the detection of depth. In view of this finding the range does not appear unreasonable, nor does the greater spread towards convergent disparities indicated in Fig. 4, because of the geometric situation: if the eyes of cat 13 were converging on a point at 147 cm, the divergent spread would go to infinity, the convergent to 39 cm.

This discovery of surprising specificity of response at an early level in the visual system fits in with the trend of recent discoveries on the visual systems of vertebrates and invertebrates, where the trigger features are often amazingly specific, even at precortical levels (Barlow, 1953; Lettvin, Maturana, McCulloch & Pitts, 1959; Maturana & Frenk, 1963; Waterman & Wiersma, 1963; Barlow, Hill & Levick, 1964; Waterman, Wiersma & Bush, 1964). Furthermore, there is an indication that the mechanism of achieving this specificity may be similar, for it will be seen in Fig. 1, and even better in the work with post-stimulus time histograms (Pettigrew *et al.* 1967*b*) that one eye 'vetos' the response of the other eye when the disparity is incorrect. Thus it may be another example of the kind of mechanism proposed by Barlow & Levick (1965) to account for directional selectivity in ganglion cells of the rabbit retina: here it was thought that selectivity was achieved by horizontal cells vetoing the response of bipolar cells.

Can the range of vertical disparities shown in Figs. 3 and 4 be explained by errors in our measurements and corrections? We think it is too big for this: perhaps variable vertical disparity is required to compensate and correct for vertical errors in the cat's eye movement control system, and for the vertical image disparities that inevitably arise at short viewing distances in the peripheral retina.

It is interesting to compare the action of the primary visual neurons in the cat's cortex with the mechanism for stereopsis proposed by Julesz (1961, 1965). In his experiments with random dot stereograms he found no evidence for monocular pattern recognition, on either a macroscopic

or microscopic scale, preceding the binocular analysis that yields the impression of depth. He postulates a point by point comparison for varying disparities, or degrees of lateral shift of one of the fields, and he thinks a depth impression results when a zone of similarity between the two fields is revealed by a particular lateral shift. On his scheme the recognition that two regions belong to each other, and can yield a depth cue by their disparity, depends solely upon detecting point by point similarity. On the other hand our results suggest that the cat's cortex uses a less general, more specific, method; it appears to use primitive feature filtering to recognize similarity and thus decide upon the appropriate pairing up of the parts of the two eye fields.

One should be wary of assuming that these results on the cat apply *in toto* to man. It was suggested above that two operations were required for stereopsis: recognition of some feature in each image, and assessment of the disparities of these features caused by binocular parallax. It would not be at all surprising if man, with well developed colour vision, uses different features from the cat. And in other respects there may also be important differences, for Rashbass & Westheimer (1961) have shown that convergence movements in man are exquisitely controlled. Possibly the cat, a hunting animal, surveys a wide range of depth at low accuracy, whereas man, a sophisticated toolmaker, surveys a narrow band at high accuracy, varying the position of the band with his convergence movements.

Many refinements of the methods used in this work were developed in the Department of Physiology, Sydney, and by W. R. Levick, to whom we are also indebted for help and discussion. This work was supported by Grant No. NB-05215 from the United States Public Health Service, and was performed when one of us (H.B.B.) held a Miller professorship.

REFERENCES

- BARLOW, H. B. (1953). Summation and inhibition in the frog's retina. *J. Physiol.* **119**, 69-88.
- BARLOW, H. B., HILL, R. M. & LEVICK, W. R. (1964). Retinal ganglion cells responding selectively to direction and speed of image motion in the rabbit. *J. Physiol.* **173**, 377-407.
- BARLOW, H. B. & LEVICK, W. R. (1965). The mechanism of directionally selective units in rabbit's retina. *J. Physiol.* **178**, 477-504.
- BISHOP, P. O., BURKE, W., DAVIS, R. & HAYHOW, W. R. (1958). Binocular interaction in the lateral geniculate nucleus—a general review. *Trans. ophthal. Soc. Aust.* **18**, 15-35.
- BISHOP, P. O., KOZAK, W. & VAKKUR, G. J. (1962). Some quantitative aspects of the cat's eye: axis and plane of reference, visual field co-ordinates and optics. *J. Physiol.* **163**, 466-502.
- DAVSON, H. (1962). *The Eye*, vol. 4, pp. 209-417. New York and London: Academic Press.
- HUBEL, D. H. & WIESEL, T. N. (1962). Receptive fields, binocular interaction and functional architecture in the cat's visual cortex. *J. Physiol.* **160**, 106-154.
- HUBEL, D. H. & WIESEL, T. N. (1965). Receptive fields and functional architecture in two non-striate visual areas (18 and 19) of the cat. *J. Neurophysiol.* **28**, 229-289.
- JULESZ, B. (1961). Binocular depth perception and pattern recognition. *Information theory. 4th London Symposium*, ed. CHERRY, C., pp. 212-224. London: Butterworth.

- JULESZ, B. (1965). Some neurophysiological problems of stereopsis. *Proceedings of the Symposium on Information Processing in Sight Sensory Systems*, ed. NYE, P. W. Pasadena: California Institute of Technology.
- LETTVIN, J. Y., MATURANA, H. R., MCCULLOCH, W. S. & PITTS, W. H. (1959). What the frog's eye tells the frog's brain. *Proc. Inst. Radio Engrs.* **47**, 1940-1951.
- MATURANA, H. R. & FRENK, S. (1963). Directional movement and horizontal edge detectors in the pigeon retina. *Science, N.Y.* **142**, 977-979.
- NIKARA, T., BISHOP, P. O. & PETTIGREW, J. D. (1967). Analysis of retinal correspondence by studying receptive fields of binocular single units in cat striate cortex. *J. Neurophysiol.* (In the Press.)
- OTSUKA, R. & HASSLER, R. (1962). Über Aufbau und Gliederung der corticalen Sehsphäre bei der Katze. *Arch. Psychiat. NervKrankh.* **203**, 212-234.
- PETTIGREW, J. D. (1965) Binocular interaction on single units of the striate cortex of the cat. Thesis submitted for the degree of B.Sc. (Med.) in the Department of Physiology, University of Sydney.
- PETTIGREW, J. D., NIKARA, T. & BISHOP, P. O. (1967*a*). Responses to moving slits by single units in cat striate cortex. *J. Neurophysiol.* (In the Press.)
- PETTIGREW, J. D., NIKARA, T. & BISHOP, P. O. (1967*b*). Binocular interaction on single units in cat striate cortex: simultaneous stimulation by single moving slit with receptive fields in correspondence. *J. Neurophysiol.* (In the Press.)
- POLYAK, S. (1957). *The Vertebrate Visual System*, pp. 109-110. Chicago: University of Chicago Press.
- RASHBASS, C. & WESTHEIMER, G. (1961). Disjunctive eye movements. *J. Physiol.* **159**, 339-360.
- RODIECK, R. W., PETTIGREW, J. D., BISHOP, P. O. & NIKARA, T. (1967). Residual eye movements in receptive-field studies of paralyzed cats. *Vision Res.* **7**, 107-110.
- WATERMAN, T. H. & WIERSMA, C. A. G. (1963). Electrical responses in decapod crustacean visual systems. *J. cell. comp. Physiol.* **61**, 1-16.
- WATERMAN, T. H., WIERSMA, C. A. G. & BUSH, B. M. H. (1964). Afferent visual responses in the optic nerve of the crab, *Podophthalmus*. *J. cell. comp. Physiol.* **63**, 135-155.
- WHEATSTONE, C. (1838). Contributions to the physiology of vision. Part the first: On some remarkable and hitherto unobserved phenomena of binocular vision. *Phil. Trans. R. Soc.* **II**, 371-394.