

SOME FORMAL APPROACHES TO THE ANALYSIS OF KINETIC DATA IN TERMS OF LINEAR COMPARTMENTAL SYSTEMS

MONES BERMAN, MARJORY F. WEISS, and EZRA SHAHN

From the National Institute of Arthritis and Metabolic Diseases, National Institutes of Health, Bethesda. Mr. Shahn's present address is the Johnson Foundation for Medical Physics, Philadelphia.

ABSTRACT A formal approach to the routine analysis of kinetic data in terms of linear compartmental systems is presented. The methods of analysis are general in that they include much of the theory in common use, such as direct solution of differential equations, integral equations, transfer functions, fitting of data to sums of exponentials, matrix solutions, etc. The key to the formalism presented lies in the fact that a basic operational unit—called “compartment”—has been defined, in terms of which physical and mathematical models as well as input and output functions can be expressed. Additional features for calculating linear combinations of functions and for setting linear dependence relations between parameters add to the versatility of this method. The actual computations for the values of model parameters to yield a least squares fit of the data are performed on a digital computer. A general computer program was developed that permits the routine fitting of data and the evolution of models.

I. INTRODUCTION

Considerable work has been done on the analysis and interpretation of kinetic data in terms of linear compartmental systems,¹ the motivation for this being, in part, the fact that small perturbations on higher order systems manifest themselves as first order transients (*e.g.*, tracer kinetics, relaxation phenomena, etc.). It is the purpose of this paper to present a general framework within which the solution of problems involving compartmental models may be executed routinely.

A linear compartmental system is usually specified by a number of compartments and by transition probabilities between compartments, and may be represented mathematically by a set of differential equations

$$\dot{f}_i(t) = \sum_{j=1}^n \lambda_{ij} f_j(t) \quad (i = 1, \dots, n) \quad [1]$$

¹ Comprehensive bibliographies appear in references (1, 8, 12), where basic assumptions and definitions are discussed.

where $f_i(t)$ represents a function, such as amount of material, specific activity etc., the λ_{ij} are the transition probabilities per unit time (or turnover rates) from the j^{th} into the i^{th} compartment, and λ_{ii} is defined

$$\lambda_{ii} = - \sum_{\substack{k=0 \\ k \neq i}}^n \lambda_{ki} \quad [2]$$

λ_{0i} represents "loss" from the i^{th} compartment to the outside.

When the $[\lambda_{ij}]$ matrix has distinct eigenvalues, the solutions of equations [1], for constant λ_{ij} , are sums of exponentials:

$$f_i(t) = \sum_{j=1}^n A_{ij} e^{-\alpha_j t} \quad (i = 1, 2, \dots, n) \quad [3]$$

where the $(-\alpha_j)$ are the eigenvalues of the $[\lambda_{ij}]$ matrix and the A_{ij} are elements of the eigenvectors. In matrix notation

$$\lambda = A\alpha A^{-1} \quad [4]$$

where α is a diagonal matrix of the α_j elements.

Explicit solutions for the case of multiple roots and some time dependent λ_{ij} may also be derived (17).

To derive a compartmental model the solution of which will agree with experimental data that are measures of the $f_i(t)$, the number of compartments and the values for the λ_{ij} must be determined. Strictly speaking, there is no unique model for a set of data since one can always expand any model by the introduction of degeneracies or fine structure beyond the resolution possible from the data. In practice, however, one usually seeks a model with a minimum number of compartments, unless independent information is available to the contrary.

With the number of compartments set, a minimum number of measures of the $f_i(t)$ is still required to determine values for the λ_{ij} . When the data are fewer than the required minimum, as is frequently the case, a unique set of values cannot be defined.

Additional degrees of freedom in choosing a model arise when any of the measured quantities is a linear combination of the $f_i(t)$ with unknown coefficients.

Statistical fluctuations in the data introduce further uncertainties in a model.

Apart from the intrinsic limitations in defining a model, the actual computations may become quite complex. Several approaches are frequently used individually or in combination in dealing with these problems:

(a) Special assumptions are postulated about the model (1-4, 4a). Such assumptions usually set some $\lambda_{ij} = 0$, restricting the possible compartmental interconnections so that a "simple" model results. This permits simplification of the computations and the definition of the unknown λ_{ij} .

(b) The model is not fully defined but certain λ_{ij} or other parameters can be

calculated using one or several of the differential equations. Special procedures, such as the use of derivatives, times for the occurrence of extrema, mean times, etc. are frequently invoked to accomplish this (14, 8).

(c) Mapping of models within a hyperspace may be possible when the models are not too complex and the degrees of freedom are not too great (4, 4a, 5).

(d) Integral equations and/or transfer functions are employed to describe the response of models or parts of models in terms of mathematical functions and to predict their response to various input functions (6–9a).

Although the above procedures have been very successful for many special studies, they are neither general enough nor sufficiently practical to handle problems routinely. They require computational simplicity and cannot always make full use of all available information, especially when constraints within the model are specified *a priori*.

The treatment presented here is an attempt to develop a general formalism applicable routinely to all problems. The framework developed for this permits the direct or indirect utilization of the various theoretical approaches already available. The data are treated statistically and uncertainties for the parameters of the model are derived (13).

Much of that which is presented here was made possible by the advent of high speed digital computers, by some theoretical work developed in recent years (2, 4, 4a, 6, 6a, 8–12) and by special techniques introduced here. The actual solutions for all the procedures proposed here can be performed on a computer using a general program described separately (13) and do not require any further programming. When discussing various methods for setting up models and solving them it is implied that, using the computer program, it is possible to derive a set of values for the parameters of the proposed model which yields a least squares fit of the data.

II. OPERATIONAL UNITS

For the purposes of simplicity in the subsequent discussions it is convenient to define certain operational units. These are based on features that are already integral parts of the computational formalism. The units defined are: compartment, summer, function generator, and transfer function.

1. *Compartment.* A compartment is an entity that operates on a function in accord with the differential equations given by [5] below. For any arbitrary input rate $g(t)$, compartment i may be described by $f_i(t)$:

$$\frac{df_i(t)}{dt} = \lambda_{ii}f_i(t) + g(t). \quad [5]$$

Here λ_{ii} may represent an irreversible loss ($-\lambda_{0i}$) from compartment i or the negative sum of a number of component λ_{ji} which serve as “outputs” to other compartments ($j \neq 0$).

Physiologically, a compartment symbolizes a totality of particles within the system that are operationally indistinguishable from each other as judged by the available data. This may or may not correspond to an identifiable physiological entity.

A circle will be used to represent a compartment schematically. The λ_{ij} will be represented by arrows with a direction from j to i . An example for a 3 compartment model is shown in Fig. 1.

2. *Summer.* As the name implies, a summer is an operational unit that

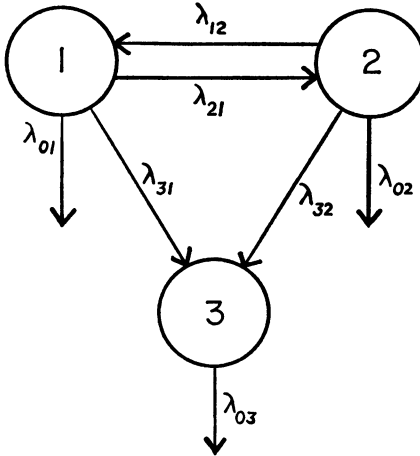

FIGURE 1 Special 3 compartment model.

represents a linear combination of compartments and is expressed mathematically by the relation

$$q_i = \sum_{\substack{k=1 \\ k \neq i}}^n \sigma_{ik} f_k \quad [6]$$

where q_j is the function describing the summer j , f_k are the functions for compartments k , and σ_{jk} are the summing coefficients.

When only one compartment is involved,

$$q_i = \sigma_i f_i \quad [7]$$

and a summer may be eliminated by use of a proportionality constant, κ_i

$$q_i = \kappa_i f_i. \quad [8]$$

A summer is represented schematically by a triangle, and lines (without arrows) between summers and compartments represent the σ_{jk} . This is shown in Fig. 2 where 1, 2, and 3 are compartments and 4 and 5 are summers.

3. *Function Generator.* A function generator is a device which generates a desired function, that may then serve as an input to a system of compartments

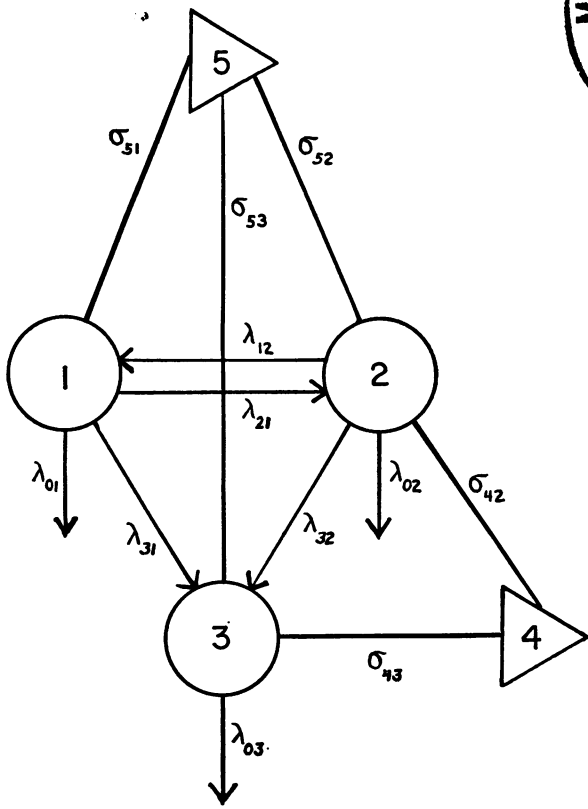

FIGURE 2 A 3 compartment model with summers. Summer 4 represents linear combination of compartments 2 and 3; summer 5 represents linear combination of compartments 1, 2 and 3.

without being affected by changes in the system or in its degree of coupling to the system. The generated functions are limited to sums of exponentials, and are obtained by the use of compartments. The independence of a function generator from the system is obtained by making use of linear dependence relations of the type:

$$\lambda_{ij} = \sum_{l,m} a_{i,l,m} \lambda_{lm} \quad [9]$$

where the $a_{i,l,m}$ are constant coefficients.

The utility of these concepts is seen as follows. Assume a compartment i with a rate of loss, α_i , and initial conditions $f_i(0)$. Its response as a function of time is

$$f_i(t) = f_i(0)e^{-\alpha_i t}. \quad [10]$$

This is shown schematically in Fig. 3 where $*f_i(0)$ indicates the initial conditions for compartment i .

When compartment i serves as an input to another compartment, Fig. 4, at a rate

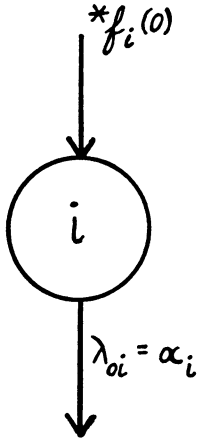

FIGURE 3 Schematic representation for compartment.

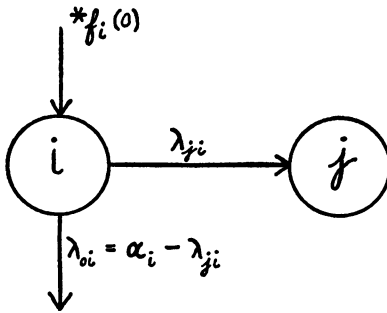

FIGURE 4 Compartment converted to function generator by use of dependence $\lambda_{oi} = \alpha_i - \lambda_{ji}$.

λ_{ji} , its response $f_i(t)$ is

$$f_i(t) = f_i(0)e^{-(\lambda_{oi} + \lambda_{ji})t}.$$

To maintain $f_i(t)$ in the form given by [10], and independent of λ_{ji} , the following dependence relation is specified

$$\lambda_{oi} = \alpha_i - \lambda_{ji}. \quad [11]$$

When compartment i serves an input to several compartments, the dependence relation is extended to include the other λ_{ki} :

$$\lambda_{oi} = \alpha_i - \sum_{\substack{k=1 \\ k \neq i}}^n \lambda_{ki}. \quad [12]$$

When a linear combination of exponentials is desired for an input function, separate compartments are used for each of the exponentials, with each having its own dependence relations to ensure independence of coupling to the system. Thus, for example, a function which is a sum of 3 exponentials,

$$A_1 e^{-\alpha_1 t} + A_2 e^{-\alpha_2 t} + A_3 e^{-\alpha_3 t},$$

feeding into compartments i and j may be set up as shown in Fig. 5, with the following dependence relations

$$\left. \begin{aligned} \lambda_{01} &= \alpha_1 - \lambda_{j1} - \lambda_{i1} \\ \lambda_{02} &= \alpha_2 - \lambda_{j2} - \lambda_{i2} \\ \lambda_{03} &= \alpha_3 - \lambda_{j3} - \lambda_{i3} \end{aligned} \right\} \quad [13]$$

and

$$\left. \begin{aligned} \lambda_{j3} &= \lambda_{j2} = \lambda_{j1} \\ \lambda_{i3} &= \lambda_{i2} = \lambda_{i1} \end{aligned} \right\} \quad [14]$$

Equations [14] arise because the same fraction of each exponential component must feed into compartments i , or j . Again, $*A_i$ is used to specify initial conditions for compartment i .

A function generator will be represented schematically by a square having a single designation. An arrow to a compartment represents an input to that compartment. If a number appears in the upper left-hand corner of the square, it designates the number of exponentials involved. All the necessary compartments, initial condi-

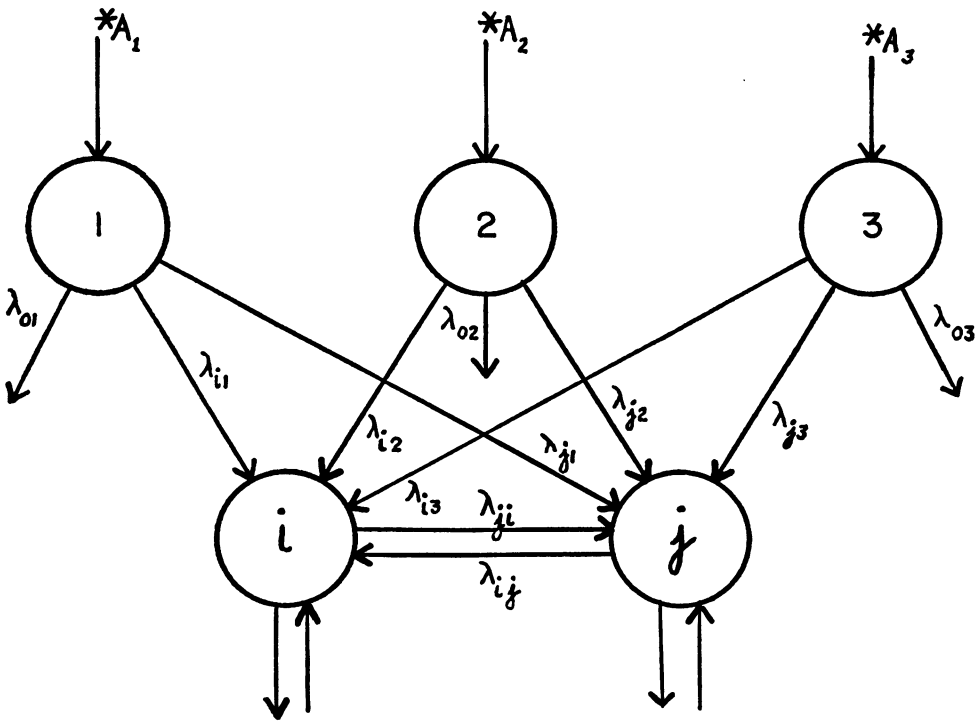

FIGURE 5 Function generator with 3 exponentials $A_1e^{-\alpha_1t} + A_2e^{-\alpha_2t} + A_3e^{-\alpha_3t}$ serving as input to compartments i and j .

tions, decay constants and dependence relations for the function generator will be implied by this notation. This is shown in Fig. 6, which is formally equivalent to Fig. 5.

A summer can add the responses of the individual compartments of a function generator to obtain the entire function, Fig. 7. A single line between the function generator and the summer will imply the presence of all the necessary summing coefficients, σ_{lk} .

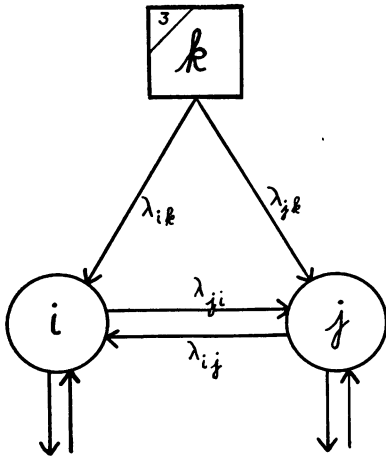

FIGURE 6 Schematic representation for function generator.

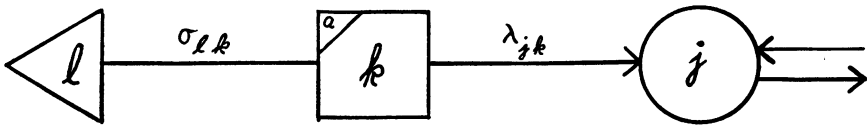

FIGURE 7 Summer used to represent output of function generator.

4. *Transfer Function.* A transfer function is an operational definition of a black box necessary to convert a given input into a specified output. Formally, it is defined as the ratio of the Laplace transform of the output function to the Laplace transform of the input function. When the input function is a unit impulse, its Laplace transform is unity and the transfer function equals the Laplace transform of the output function.

In the real time domain, if $f(t)$ is the output for a unit impulse input, the output $r(t)$ for any other input, $g(t)$, may be obtained by the convolution of the two functions:

$$r(t) = m(t) + \int_0^t f(\Theta)g(t - \Theta) d\Theta \quad [15]$$

where $m(t)$ is the output resulting from initial conditions already present in the system. The Laplace transform of [15] is

$$R(P) = M(P) + F(P) \cdot G(P) \quad [16]$$

where $R(P)$, $M(P)$, $F(P)$ and $G(P)$ are the Laplace transforms of $r(t)$, $m(t)$, $f(t)$, and $g(t)$, respectively.

For compartmental systems, the output for a unit impulse input may be expressed as a sum of exponentials, $f(t) = \sum A_i e^{-\alpha_i t}$. Thus, regardless of how the system is interconnected it may be represented operationally by a number of compartments having decay constants α_i and initial conditions A_i , Fig. 8.

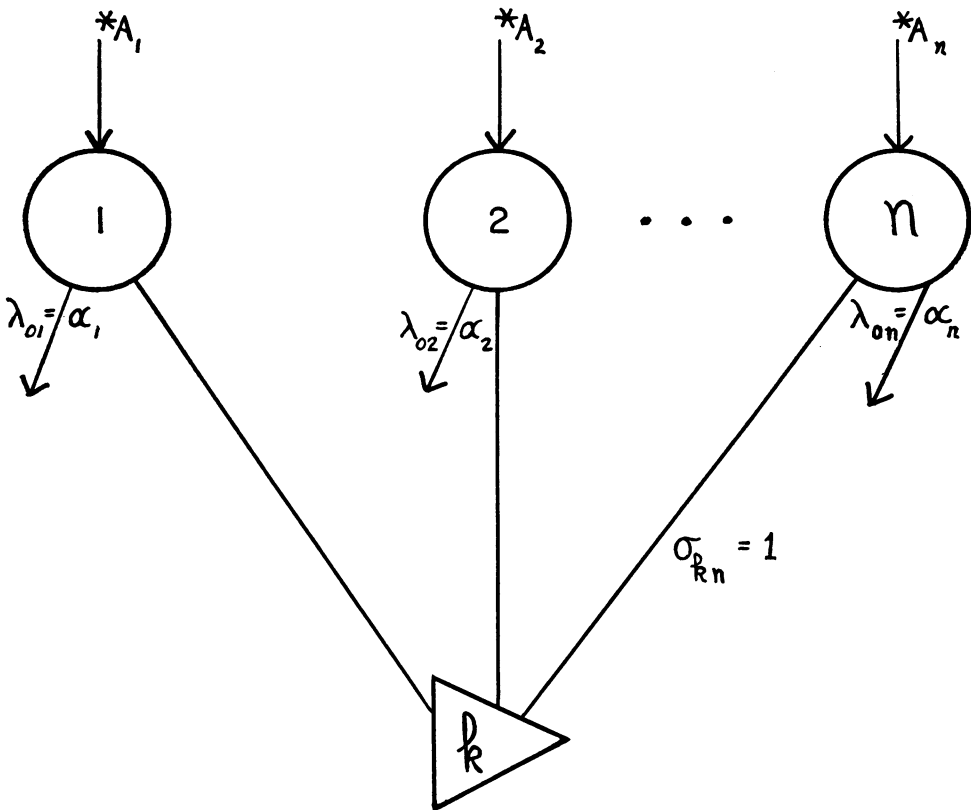

FIGURE 8 Operational arrangement for transfer function.

When the input to the system is $g(t)$, the output, $r(t)$, appears in the summer k for the scheme shown in Fig. 9. To see that this is in fact so, the response $q_i(t)$ for any compartment i ($i = 1, \dots, n$) may be calculated directly as

$$\frac{dq_i(t)}{dt} = -\alpha_i q_i + A_i g(t). \quad [17]$$

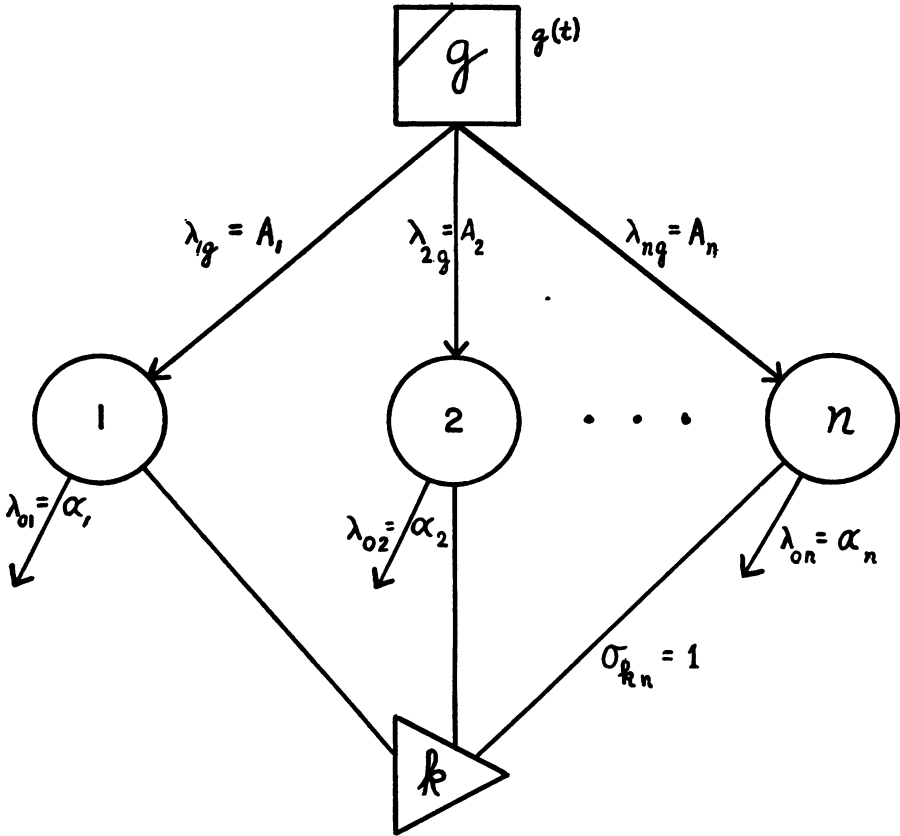

FIGURE 9 General input $g(t)$ to system having transfer function $\sum_{i=1}^n A_i e^{-\alpha_i t}$. Note that rate constants λ_{ig} take on values of initial conditions A_i in Fig. 8.

Using Laplace transform notation:

$$pQ_i(p) - q_i(0) = -\alpha_i Q_i(p) + A_i G(p)$$

$$Q_i(p) = \frac{q_i(0)}{p + \alpha_i} + \left[\frac{A_i}{p + \alpha_i} \right] G(p)$$

$$Q_i(p) = M_i(p) + F_i(p) \cdot G(p) \quad [18]$$

Finally, considering the total output as the sum of the individual outputs, $R(p) = \sum Q_i(p)$, we get

$$R(p) = M(p) + F(p) \cdot G(p) \quad [19]$$

which agrees with [16], and its inverse transform is [15] with $f(t) = \sum A_i e^{-\alpha_i t}$.

A transfer function will be represented schematically by a diamond, Fig. 10. Arrows indicate inputs or outputs. This representation will imply the existence of all the necessary compartments and rate constants discussed above. A number in the

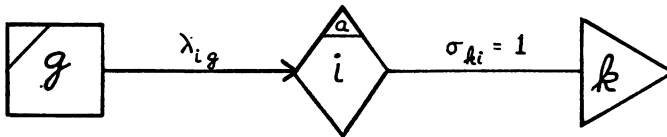

FIGURE 10 Schematic representation of transfer function i . Function generator g represents input and summer k represents output.

upper corner of the diamond designates the number of compartments necessary to represent the transfer function.

The total response of a transfer function may be obtained by summing the responses of the individual compartments within it. A single line will show the coupling of a transfer function to a summer.

The output from a transfer function may be used as inputs to other parts of the system, in which case the transfer function response may be maintained independent of variations in the values of the output parameters, λ_{ij} , by use of dependence relations as was done in the case of the function generator. This will be discussed later.

III. SOLUTION OF MODELS

In setting up a model some *a priori* knowledge about the system may be available, but more frequently one has to be guided by the data. The most useful clue is the fact that the data must be linear combinations of exponentials, to agree with the solutions of the differential equations, and that the same set of exponentials must apply to all compartments (except for degeneracies). This suggests that the data be fitted first to linear combinations of exponentials, and that a number of compartments for a model be chosen to equal the number of exponentials in the fit (4). Various methods may be employed subsequently in going from a sum of exponentials fit to the parameters of a physical model.

When it is not possible to fit the data to sums of exponentials, the initial selection of the number of compartments for a model must be made on the basis of previous knowledge or by trial and error. The computations for the values of the model parameters may be carried out by using the differential equations directly.

Various approaches for the use of sums of exponentials, for the direct model solution and for combinations of the two will be discussed in what follows.

1. *Solution Involving Model Parameters Directly.* The most direct method of solving for a model is to set it up in terms of the differential equations directly, and let the values of the variable parameters be adjusted until a least squares fit of the data is obtained, a numerical chore performed on the computer. This method is highly desirable because it calculates the final values directly, yields measures for their uncertainties, can accept data in "raw" form and requires no intermediate calculations. Furthermore, known constraints on the model (e.g., $\lambda_{ij} = 0$) can be incorporated directly in the differential equations.

The disadvantages of the method are: (a) it is difficult to decide on the number of compartments for the model, (b) it may be difficult to assign initial estimates for the values of the parameters (a requirement of the numerical procedure) and, (c) convergence may be slow due to interdependence of parameters in the fitting of the data.

2. *Fitting of Data to Sums of Exponentials.* The method for the fitting of the data to linear combinations of exponentials is shown in Fig. 11. Each compart-

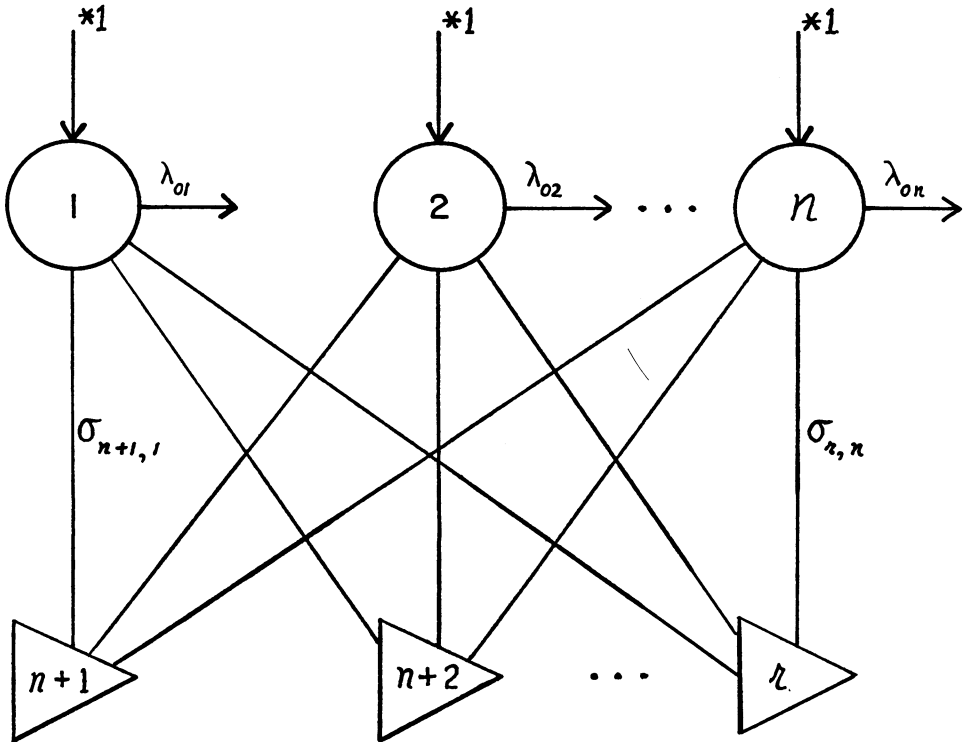

FIGURE 11 Arrangement for fitting r - n sets of data to sums of n exponentials each, with common exponential constants (λ_{oi}).

ment i ($i = 1, \dots, n$) generates an exponential $e^{-\lambda_{oi}t}$ (a constant is generated by a compartment having a $\lambda_{oi} = 0$), and each summer ($n+1$) to r represents a best linear combination ($\sigma_{n+j,i}$) of the same exponentials to fit each of the available sets² of data:

$$a_{n+j}(t) = \sum_{i=1}^n \sigma_{n+j,i} f_i(t). \quad [20]$$

² A set of data consists of all measures for a single compartment or for any linear combination of compartments.

Certain constraints may sometimes be imposed when fitting data to sums of exponentials. For example, if initial conditions, $q_i(0)$, are given, it is necessary that

$$\sum_{\substack{j=1 \\ j \neq i}}^n \sigma_{j,i} = q_i(0) \quad (i = n + 1, n + 2, \dots, r)$$

be satisfied. This may be entered as a dependence relation in the computations.

Other constraints may arise as a result of functional relations between compartments. For example, the rate of accumulation of radioactivity in the urine, dq_u/dt , is frequently proportional to the amount of radioactivity in the plasma, $q_p(t)$:

$$\frac{dq_u(t)}{dt} = \kappa q_p(t) \quad [21]$$

where κ is a proportionality constant.

If $q_p(t)$ has the form

$$q_p(t) = \sum_i \sigma_{p,i} e^{-\alpha_i t}$$

then

$$q_u(t) = \int_0^t \kappa q_p d\tau + q_u(0) = \sum_i \int_0^t \kappa \sigma_{p,i} e^{-\alpha_i \tau} d\tau + q_u(0)$$

$$q_u(t) = \sum_i \sigma_{u,i} \int_0^t \kappa e^{-\alpha_i \tau} d\tau + q_u(0). \quad [22]$$

Thus, the constraint of [21] is equivalent to that of [22] and may be incorporated in the fitting procedure. The format of [22] corresponds to the operational arrangement shown in Fig. 12.

Compartments 1 to n generate the exponentials $e^{-\alpha_i t}$ ($i = 1, \dots, n$). Compartments $(n+1)$ to $(2n)$ generate the functions

$$\int_0^t \lambda_{n+i,i} e^{-\alpha_i \tau} d\tau.$$

Summer u represents

$$q_u(t) = \sum_{i=1}^n \sigma_{u,n+i} \int_0^t \lambda_{n+i,i} e^{-\alpha_i \tau} d\tau. \quad [23]$$

Equation [22] is satisfied if the following dependence relations are specified:

$$\lambda_{n+i,i} = \kappa \quad (i = 1, \dots, n) \quad [24]$$

$$\sigma_{u,n+i} = \sigma_{p,i}$$

Similar procedures may be applied to other functional relations between compartments.

To fit data to sums of exponentials, initial estimates for the λ_{0i} only are necessary. These may be obtained by the "peeling" technique (15), or other available methods. The basic problem as to how many exponentials are necessary to fit a set of data has

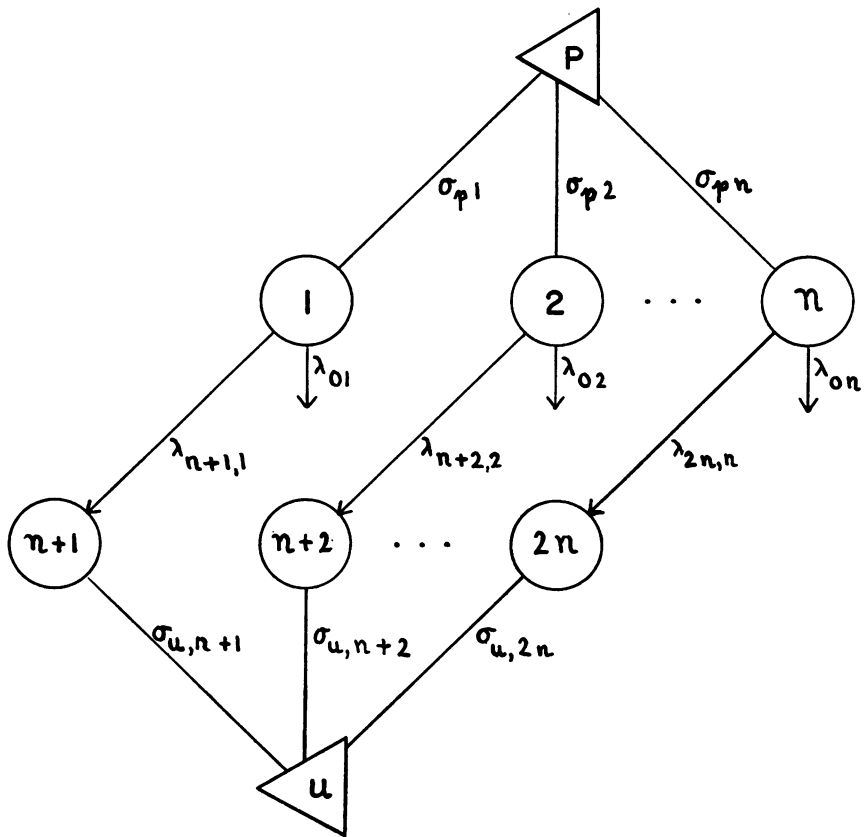

FIGURE 12 Compartment arrangement for fitting two sets of data (q_p and q_u) to sums of exponentials with the constraint that

$$\frac{dq_u(t)}{dt} = \kappa q_p(t)$$

not been fully resolved. One usually chooses the minimum number necessary to yield a random scatter of the experimental points about a fit. The use of a reference fit (13, 16) is helpful.

The procedure for fitting data to sums of exponentials may cause some difficulty when the system has multiple or "near multiple" roots. Functions for the case of multiple roots can be obtained directly by setting up compartments in series with unidirectional flow rates ($\lambda_{i+1,i}$) from the i^{th} to the $(i+1)^{\text{st}}$ compartment. The $\lambda_{i+1,i}$ have the same values for all i and the number of compartments in series equals the multiplicity of a root. This method is equivalent to the use of a Jordan canonical form of a matrix (17).

3. Model Determination from Sums of Exponentials Fit. If n exponential

terms are necessary to fit the data, a proposed model to explain the data must have at least n compartments. To determine uniquely the values for all the λ_{ij} , measures must be available for all compartments (4). Thus, if $n^2 \sigma_{ij}$ and $n \alpha_j$ can be determined from the sums of exponentials fit, the values for the λ_{ij} may be calculated from the matrix relation:

$$\lambda = \sigma \alpha \sigma^{-1} \quad [25]$$

where the σ matrix is equivalent to the A matrix in [4].

This procedure is simple and straightforward. Its application, however, may be limited due to the following: (a) Uncertainties for the values of the λ_{ij} are not obtained directly. (b) Known constraints on λ_{ij} cannot be imposed on the solution. (c) Data that are linear combinations of compartments require further mappings to obtain the final solution.

Even if the direct application of [25] is limited it may still serve a useful purpose in providing initial estimates for the λ_{ij} which may then be calculated by the direct method discussed previously or by other methods to be discussed.

When all the σ_{ij} cannot be determined from the sums of exponentials fit but a sufficient number of λ_{kl} are known so that a unique solution of a model exists, several approaches—some of which are discussed in other sections of this paper—may be followed. It is worth pointing out that usually, when calculating values for the σ_{ij} , constraints that may arise as a result of known λ_{kl} are not considered. Thus, the given σ_{ij} and λ_{kl} may be mutually incompatible.

One approach is to rewrite the set of differential equations [1] to include the information on the known λ_{kl} . If the fitted curves are good enough approximations to the true curves, the values of $f_i(t)$ and $df_i(t)/dt$ for every known i and time t may be determined analytically from the sums of exponentials fit:

$$\begin{aligned} f_i &= \sum_j A_{ij} e^{-\alpha_j t} \\ \frac{df_i(t)}{dt} &= - \sum_j A_{ij} \alpha_j e^{-\alpha_j t} \end{aligned} \quad [26]$$

With the unknown A_{ij} designated as A_{ij}' , the original differential equations [1] may be rewritten in terms of the fitted $f_i(t)$ and $df_i(t)/dt$ values (from equations [26]) and the unknown exponentials $A_{ij}' e^{-\alpha_j t}$:

$$\frac{df_i(t)}{dt} = \sum_j \lambda_{ij} f_j(t) = \lambda_{ii} f_i(t) + \sum_j \lambda_{ij} \sum_k A_{jk}' e^{-\alpha_k t} \quad (i = 1, \dots, n) \quad [27]$$

Since the functions $e^{-\alpha_k t}$ are known, [27] represents a set of linear algebraic equations in variables that are functions of the λ_{ij} and A_{jk}' . Subsequent decoupling of the λ_{ij} and A_{jk}' is necessary.

Limitations of this method are: (a) it may be difficult to decouple the λ_{ij} from the A_{jk}' ; (b) poor choice of exponentials in the fit may influence calculations; (c)

The variables of the algebraic equation may not be independent, resulting in singular equations.

4. *Combined Integral-Differential Solution.* In principle, this method combines the sums of exponentials approach with the direct model solution approach. Information or constraints on the exponentials can be specified independently of and jointly with information or constraints about the model. This method does not require that all σ_{ij} or α_j of the exponentials fit be known, provided sufficient λ_{ki} are known to ensure a unique solution.

Integration of equations [1] yields the following

$$f_i(t) = \int_0^t \sum_j \lambda_{ij} f_j(\tau) d\tau + f_i(0) = \sum_j \lambda_{ij} \int_0^t f_j(\tau) d\tau + f_i(0) \quad [28]$$

The $f_i(t)$ are thus expressed as *linear* combinations of the integrals

$$\int_0^t f_j d\tau.$$

If the data are measures of the $f_j(t)$ and are fitted to sums of exponentials, we may write

$$f_j(t) = \sum_k A_{jk} e^{-\alpha_k t}$$

and substitution into [28] yields

$$f_i(t) = \sum_j \lambda_{ij} \sum_k A_{jk} \int_0^t e^{-\alpha_k \tau} d\tau + f_i(0). \quad [29]$$

Equation [29] lends itself directly to a solution by the scheme shown in Fig. 13. The top row represents function generators, $e^{-\alpha_k t}$. The compartments in the second row represent the functions

$$\int_0^t f_j(\tau) d\tau = \sum_k A_{jk} \int_0^t e^{-\alpha_k \tau} d\tau.$$

The rate constants feeding into them are the appropriate A_{jk} . Summers in the third row represent the $f_i(t)$ in accord with [29], where the summing coefficients correspond to the λ_{ij} of the model. The function generator at the right provides a constant to supply the $f_i(0)$ terms in [29].

This method requires that the data be fitted first to sums of exponentials. The values of the fit are used to specify the function generators in row 1. A_{jk} and α_k that cannot be determined by the fit become variables of the system and initial estimates for their values are required. No initial estimates are required for the unknown λ_{ij} . The calculated $f_i(t)$ appear in the summers and these are fitted to the experimental data. The final solution yields both the unknown A_{jk} and λ_{ij} .

When a certain compartment, say, l , cannot be measured, a modification of the scheme shown in Fig. 13 may be used. In this case the quantity $\sum \lambda_{lk} \int f_k dt$ must be identical to $\sum A_{lk} e^{-\alpha_k t}$. This can be accomplished by setting

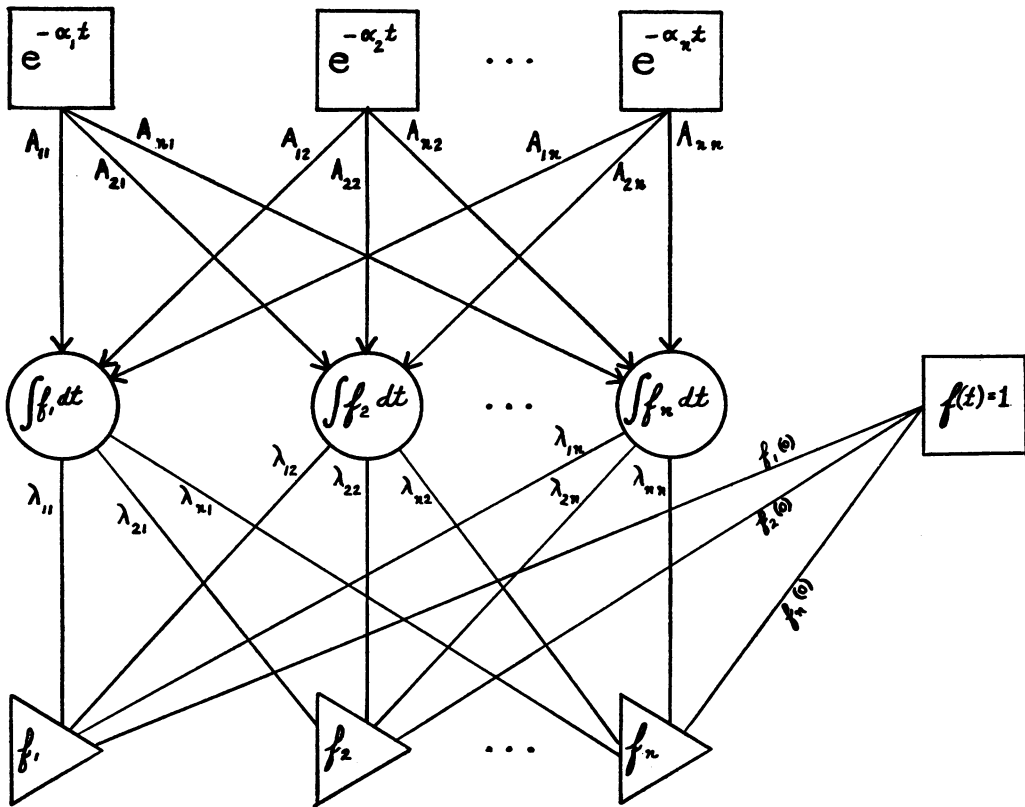

FIGURE 13 Integral-differential method for solution of model.

$$f_i \equiv \sum_{k=1}^n \lambda_{ik} \int_0^t f_k d\tau - \sum_{k=1}^n A_{ik} e^{-\alpha_k t} \equiv 0 \quad [30]$$

and by considering "zero"s as data for compartment l .

Figure 14 shows such an arrangement for summer l only. This procedure can be further extended to data for which some A_{jk} cannot be resolved. Each such term may be subtracted in the summer and the fit determined for the remaining data.

Although the method has been described in terms of compartments, the function generators of Fig. 13 can represent more complex subsystems: special models, etc.

Some advantages of the integral-differential solution are: (a) Use of the integral of the fitted data makes the method relatively insensitive to the actual number of exponentials in the original fit or to the correctness of the A_{ij} and α_j values, provided the theoretical curves fit the data. (b) Solutions for $\int f_i(t) dt$ and $f_i(t)$ can be obtained analytically. (c) Constraints on the data fitting and on the model can be imposed simultaneously in the solution.

Disadvantages of the method are: (a) Initial estimates for unknown A_{jk} are re-

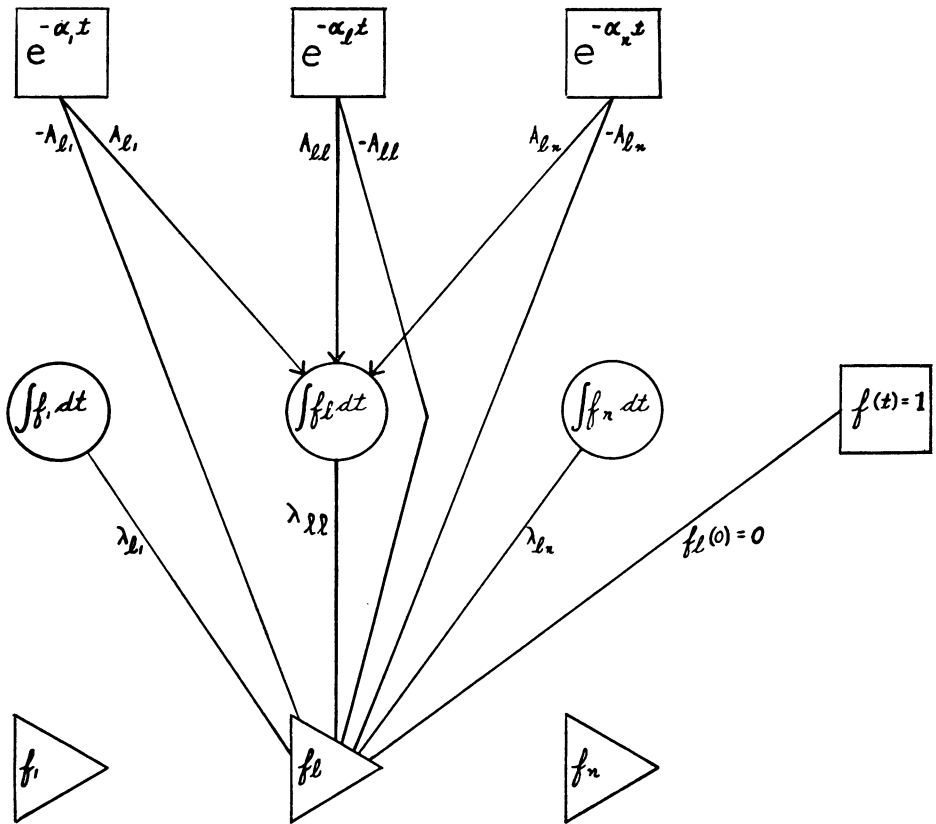

FIGURE 14 Extension of integral-differential method for case of incomplete data.

quired and may be hard to obtain. (b) The method is not convenient for data that are measures of linear combinations of compartments.

5. *Use of Function Generators.* When data are insufficient to determine a model uniquely, it may still be possible to obtain a partial solution or to describe the model operationally so that its response to various inputs may be predicted. Function generators and transfer functions may be used for this purpose. They can also be used to assist in the convergence to a least squares solution. This is accomplished in several ways: (a) The system is broken down into relatively independent subsystems resulting in independent subsets of variables. (b) Primary³ variables λ_{ij} , that are in general non-linear with respect to the responses are replaced by secondary⁴ variables σ_{ij} , that are linearly related to the responses. (c) Variables are

³ Primary variables are those that require iterative adjustments to reach a least squares solution. The λ_{ij} are primary variables.

⁴ Secondary variables are dependent on primary variables and can be determined by solution of linear algebraic equations.

decoupled in such a way as to permit time sequential solution of independent blocks of variables. These features will be demonstrated in the following example.

Assume the 3 compartment system shown in Fig. 15. The initial conditions of the experiment are $q_1(0) = 1$, and $q_2(0) = q_3(0) = 0$. Measures are available for $q_1(t)$ and $q_2(t) + q_3(t)$. It is desired to solve for all the λ_{ij} .

A direct procedure for solving this problem is shown in Fig. 16. Summer 4 represents $q_4(t) = q_2(t) + q_3(t)$. Given initial estimates for the λ_{ij} , a least squares fit

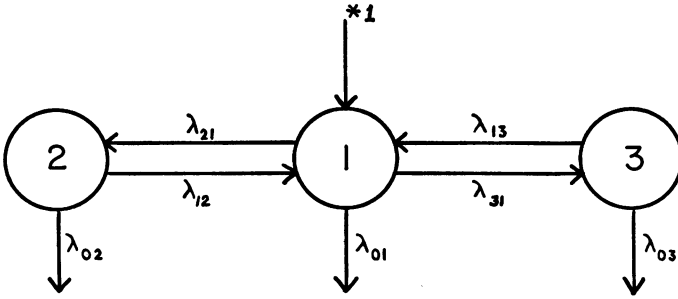

FIGURE 15 A 3 compartment model used as an example to show application of function generators.

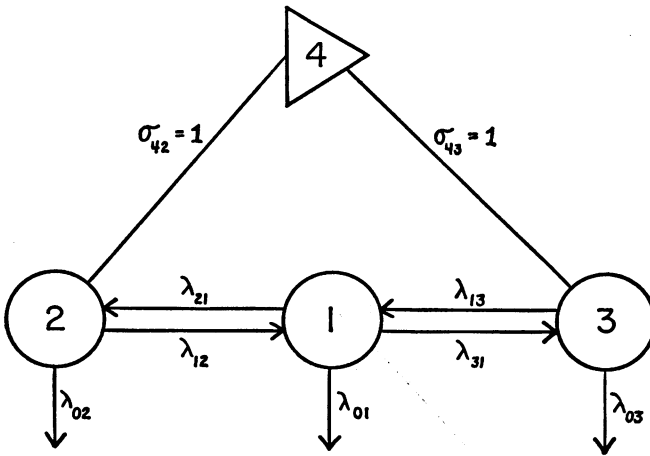

FIGURE 16 Compartmental and summer arrangement for the direct solution of model.

for $q_1(t)$ and $q_4(t)$ can be obtained. The λ_{ij} , however, are interdependent in adjusting to a least squares fit and convergence may be slow.

A function generator may be introduced as follows:

The data for compartment 1, $q_1(t)$, are first fitted to a sum of exponentials. A function generator having the identical exponentials is introduced in place of compartment 1 as indicated by function generator 5 in Fig. 17. λ_{12} and λ_{02} are combined

into a single rate constant, λ_{22} , and similarly $\lambda_{33} = \lambda_{03} + \lambda_{13}$, since no return to the function generator is desired. The response in each of the compartments in Fig. 17 is indistinguishable from the original system, and some decoupling of variables (λ_{21} and λ_{22} from λ_{31} and λ_{33}) has been achieved.

It can be shown (4, 4a) that for the arrangement in Fig. 17 the response in compartment 2 is proportional to the magnitude of λ_{21} and that this contribution to the response in summer 4 is proportional to the product $\sigma_{42} \cdot \lambda_{21}$. Since $\sigma_{42} = 1$, it is possible to set $\lambda_{21} = 1$ and make σ_{42} variable, without affecting the contribution to summer 4. The advantage of this is that λ_{21} is a primary variable whereas the σ_{42} is a secondary variable, and a reduction in the number of primary variables contributes to faster convergence. By a similar interchange between λ_{31} and σ_{43} , it is possible to eliminate another primary variable and the model reduces to that shown in

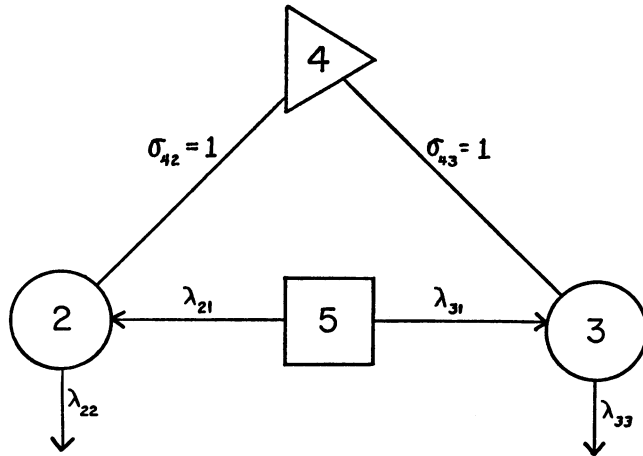

FIGURE 17 Introduction of function generator in 3 compartment model of Fig. 15.

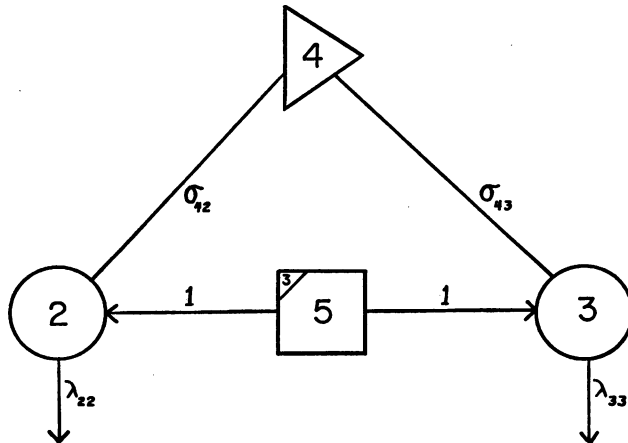

FIGURE 18 Interchange of λ_{21} and σ_{42} (λ_{31} and σ_{43}) in Fig. 17.

Fig. 18. This model may be fitted to the data $q_4(t)$, and a solution for λ_{22} , λ_{33} , σ_{42} ($= \lambda_{21}$) and σ_{32} ($= \lambda_{31}$) obtained.

The next step in the solution of the remaining parameters is shown in Fig. 19. The λ_{ij} in parentheses indicate parameters determined in the previous step. Compartment 1 [with initial conditions $q_1(0)$] and the rate constants, λ_{11} , λ_{12} , and λ_{13} have been reintroduced. The proper response for compartments 2 and 3 is maintained by the function generator and the known λ_{ij} . If the following dependence relations are specified λ_{12} and λ_{13} will not affect $q_2(t)$ and $q_3(t)$:

$$\begin{aligned} \lambda_{02} &= (\lambda_{22}) - \lambda_{12} \\ \lambda_{03} &= (\lambda_{33}) - \lambda_{13}. \end{aligned} \tag{31}$$

Thus, in effect, compartments 2 and 3 act as function generators feeding into com-

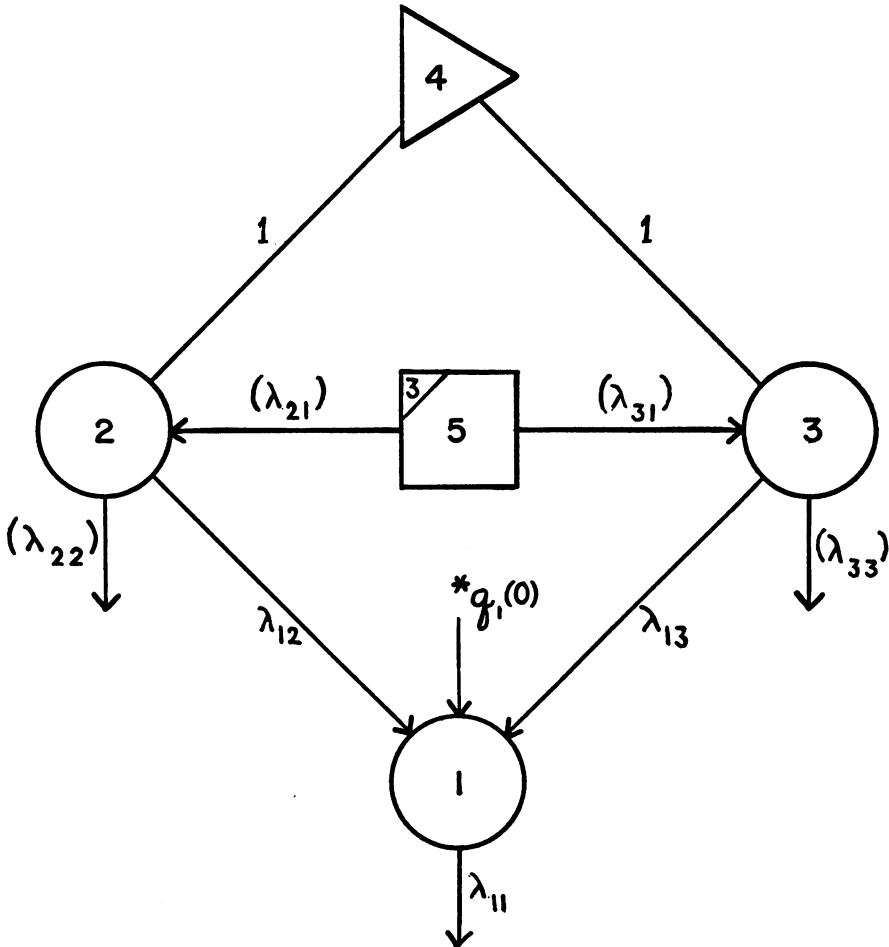

FIGURE 19 Resynthesis of compartment 1 for model in Fig. 15.

partment 1. A solution for λ_{12} , λ_{13} and λ_{11} can be obtained directly from the scheme in Fig. 19, by fitting $q_1(t)$. Alternatively, it is possible to decouple the remaining variables further if compartment 1 is represented by 3 compartments, 6, 7, and 8, and a summer, as shown in Fig. 20. The turnover rates of these compartments are set to a common value by the dependence relations

$$\lambda_{08} = \lambda_{07} = \lambda_{06} = \lambda_{11}. \quad [32]$$

Summer 1 is equivalent in its response to the original compartment 1.

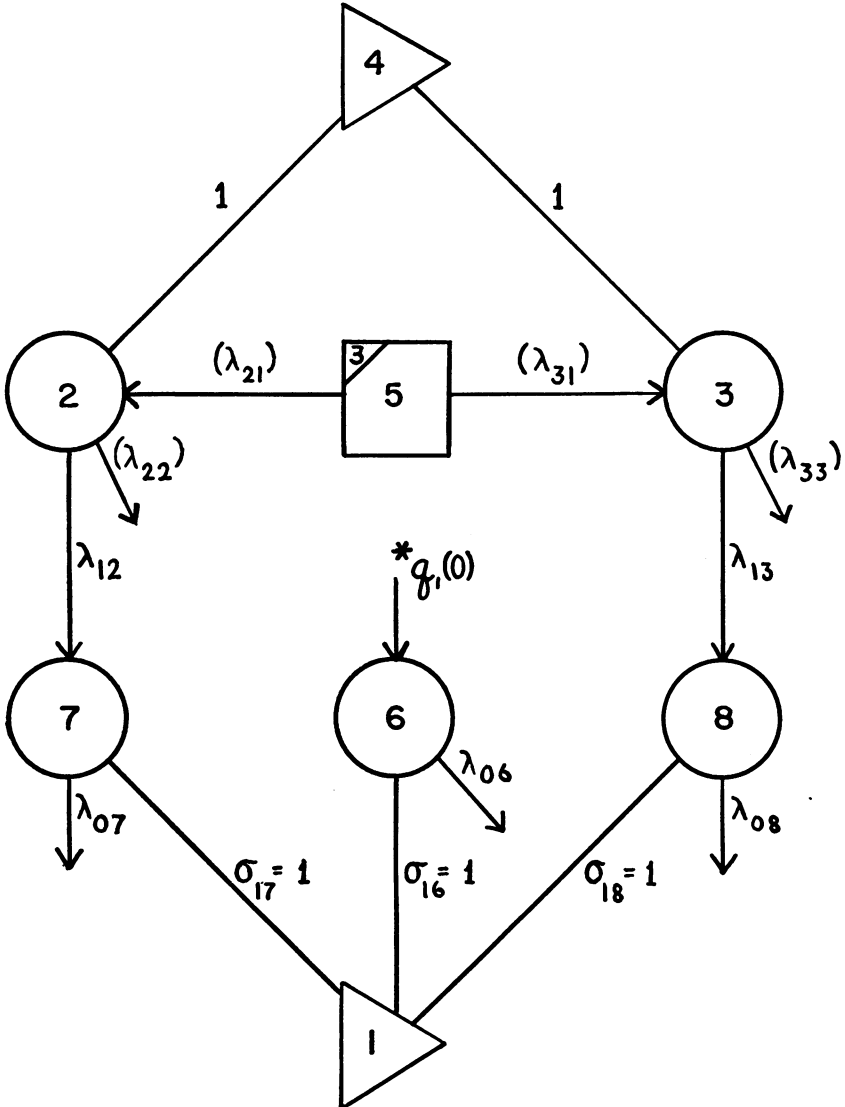

FIGURE 20 Breakdown of compartment 1, Fig. 19, into 3 compartments.

Compartment 7 represents the response of compartment 1 due to an input from compartment 2 only. Since the response in compartment 2 is fixed, the response of compartment 7 is directly proportional to λ_{12} . Summer 1 cannot resolve the product $\lambda_{12} \cdot \sigma_{17}$ and we can therefore fix $\lambda_{12} = 1$ and make σ_{17} variable. The same argument also holds for compartment 8 in relation to compartment 3 and summer 1. Compartment 6 is the response of compartment 1 due to its initial conditions only.

This final arrangement where $\lambda_{06} (= \lambda_{11})$ is the only primary variable, is shown in Fig. 21. The final solution yields $\lambda_{06} (= \lambda_{11})$, $\sigma_{17} (= \lambda_{12})$ and $\sigma_{18} (= \lambda_{13})$.

To show the use of a function generator to represent a system that cannot be resolved, consider the following situation. Data are available on blood plasma which show that it must interact with a number of other compartments. Measures for only one other compartment, say, k , are available, and it is known that it interacts with plasma only. The available data cannot resolve the entire system. The plasma data, however, may be represented by a function generator, i , feeding into compartment k having a loss λ_{0k} . The values of λ_{ki} and λ_{0k} can be determined directly from this, if sufficient data are available for the 2 compartments.

In general, a function generator need not be restricted to a sum of several independent compartments. In fact, any part of a system can be converted to serve as a function generator by introducing proper dependence relations, as was done for compartments 2 and 3 in the example.

A function generator may also be interpreted as an input function to a system. If the input function is known, the values of the parameters of the function generator are fixed. When the input function is not known, but can be determined from information about the system and its response, the parameters of the function generator become the variables in the least squares fitting of the data.

6. *Use of Transfer Function.* When the response of a system, or any part of it, to some input function is known, but the information is inadequate to permit the definition of a specific model (or a model is not desired), a transfer function may be introduced to simulate the system response. This permits the incorporation of an unresolved subsystem into a larger system and its description in terms of a minimal number of variables. The following example, based on a study of metabolism of glucose (18) will illustrate the use of a transfer function.

The disappearance of glucose C¹⁴-1 and glucose C¹⁴-6 from the plasma of a normal human after a single injection may be described by a function $f(t)$:

$$f(t) = A_1 e^{-\alpha_1 t} + A_2 e^{-\alpha_2 t} + A_3 e^{-\alpha_3 t}. \quad [33]$$

The bicarbonate radioactivity in plasma resulting from a single injection of labelled bicarbonate may be approximated by a sum of 2 exponentials

$$g(t) = B_1 e^{-\beta_1 t} + B_2 e^{-\beta_2 t}. \quad [34]$$

Part of the glucose C¹⁴-1 in the plasma is converted to plasma bicarbonate by way of a hexose monophosphate pathway. This may be represented schematically

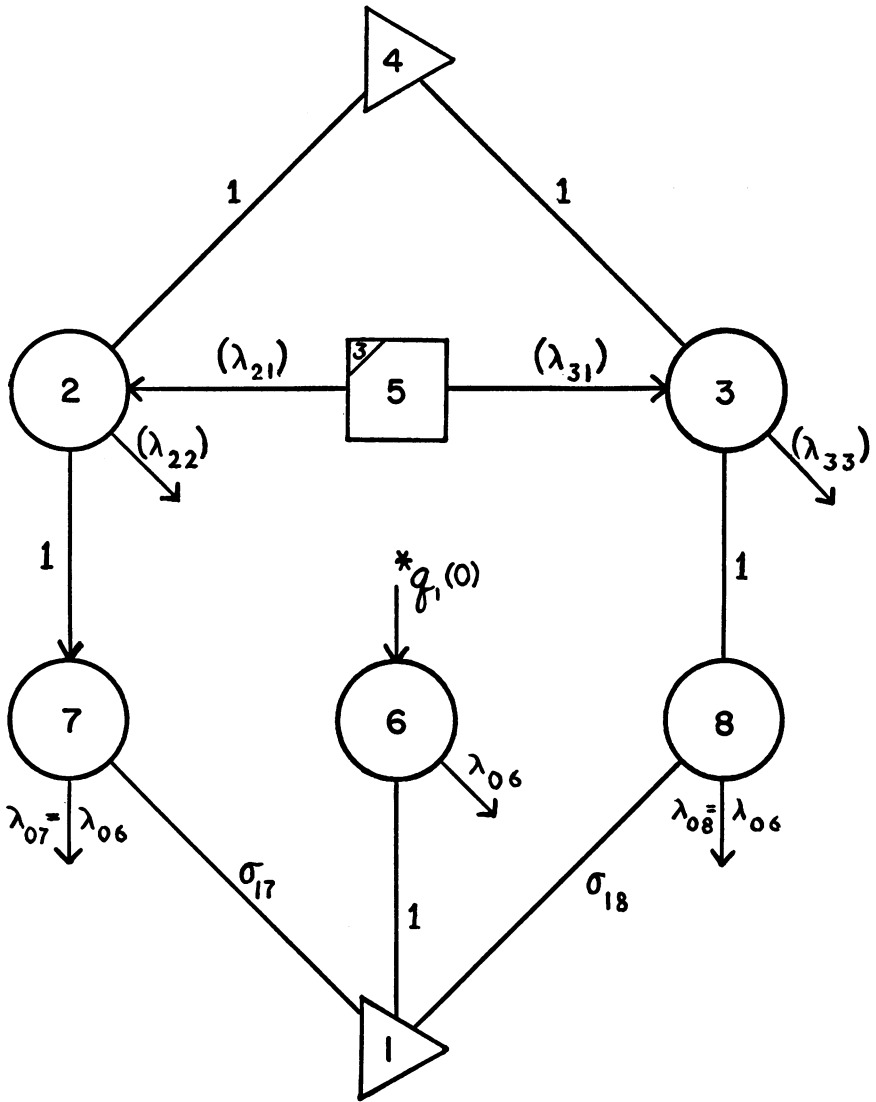

FIGURE 21 Final stage in the solution of 3 compartment model, Fig. 15, using function generator.

by function generator 1 for plasma glucose $C^{14}-1$ and transfer function 2 for plasma bicarbonate, as shown in Fig. 22. Part of glucose $C^{14}-1$ also appears as bicarbonate by another pathway. The transfer function for this pathway may be determined, from a glucose $C^{14}-6$ label, all of which is assumed to metabolize by way of this pathway. The total bicarbonate resulting from glucose $C^{14}-1$ (summer 4) is thus a linear combination of the two pathways: a fraction k goes by way of the

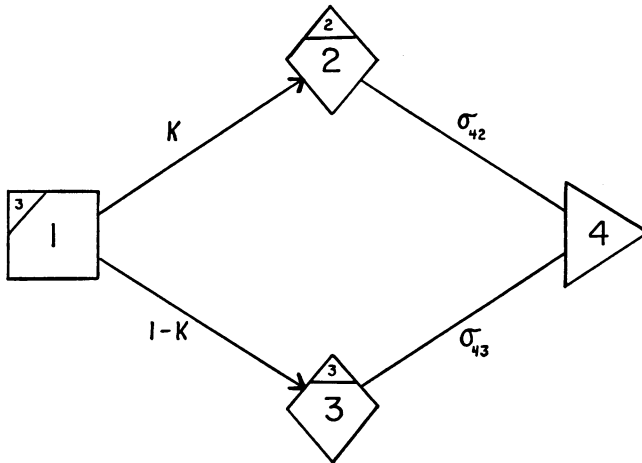

FIGURE 22 Operational representation for use of transfer function in solving for glucose metabolic pathways.

hexose monophosphate shunt and a fraction $(1-k)$ by way of the other pathway. The variable of the system is k .

When the output of a system is given for a known input, the transfer function can be determined by letting the parameters of the transfer function become the variables of the system.

Frequently, several transfer functions may be known for a system, but they may still not be sufficient to define a model. One could generate each transfer function separately and use it independently of the others, with a common input. It is not necessary to restrict oneself, however, to isolated compartments for transfer functions. Models with interacting compartments may also be used as transfer functions, in which case the same model may generate a number of transfer functions simultaneously.

A model to generate several transfer functions may be obtained as follows. The general solution of a model in terms of the exponential components in the data was given by [4]:

$$\lambda = A\alpha A^{-1}.$$

A transfer function is equivalent to a single row in the A matrix. When some of the A_{ij} are unknown, a unique solution of a model is not possible. But as pointed out in reference (4, 4a) any arbitrary set of values for the unknown A_{ij} that will be compatible with the initial conditions of the experiment and that will not result in a singular matrix A will yield a model that will be compatible with all the known A_{ij} . Such a model may have negative values for the λ_{ij} , which are not acceptable as solutions for a real *physical* model, but are of no concern when the model is to serve only as a transfer function.

The use of a general model for all transfer functions has the further advantage that it is closely linked to a physical model and can readily be transformed into one when desired.

The disadvantage of a general model as a transfer function is that it cannot be recognized readily in its simplest mathematical form. As a result of this, a general model cannot be used to derive a transfer function because it has too many degrees of freedom, and thus the solution is not unique.

IV. DISCUSSION

A number of methods have been presented for the analysis of data in terms of physical or mathematical models. All these methods are treated by a common formalism, the fundamental operational unit of which is a "compartment," with the additional features of "dependence" of parameters and "summers." With this in mind, the various methods are not really different but rather special variations of a common approach. Similarities between the methods presented are therefore to be expected. A good example of this is the use of transfer functions as input functions, output functions and as operational representations of the system. In fact, the separation of all these is really arbitrary.

The choice of a method for a specific problem depends on the kind of data available, on the purpose of the analysis and on the computational procedures involved. In general, the fitting of data to sums of exponentials is helpful in guiding subsequent choices. Some of the advantages and disadvantages of the individual methods have been discussed in the text.

The present paper deals with the fitting of data to a model. Problems connected with criteria for accepting a fitted model, non-unique solutions and inconsistent solutions have not been considered here. Some discussion of this has been presented elsewhere (13) and a more complete treatment of this will be forthcoming (19).

When a physical model is desired for a set of data it is important that the values of the parameters in the final fit do not violate the physical realizability of the model. Although this has not been discussed in this paper, the computer program makes it possible to preset upper and lower limits for the variable parameters and, thus, can guarantee physical realizability of a model.

The computational tasks involved in the various schemes presented can be performed by the digital computer program described separately (13). It is worth mentioning that many of the operations described here can also be performed on an analog computer. The disadvantages of a conventional analog computer are that (a) it does not provide a measure for a "good" fit, (b) it does not provide a systematic way for adjusting parameter values to improve a fit, and (c) it has no provision for indicating uniqueness of fit or uncertainties in the values of the parameters. These disadvantages, however, are not inherent in the analog computer and some efforts to overcome them have been made (20).

The treatment presented here deals chiefly with the λ_{ij} of a model. There are other parameters that may also be of concern in a compartmental system; the sizes of the compartments, the amount of steady-state material entering or leaving compartments, etc. A solution for these parameters may be obtained from the matrix relation $S = \lambda^{-1} I$ where S and I are column matrices of the compartment sizes and inflow rates, respectively. Neither the S_i nor I_i , however, can at present be readily used as independent variables in fitting the data. Given a set of λ_{ij} , however, either the S_i or I_i can be calculated from the above relation.

In addition to the studies already mentioned on glucose metabolism (18) and iodine kinetics (16), the methods described have been applied to problems dealing with kinetics of cholesterol (21), aldosterone (22), citrate (23), and others.

Received for publication, January 14, 1962.

REFERENCES

1. ROBERTSON, J. S., Theory and use of tracers in determining transfer rates in biological systems. *Physiol. Rev.*, 1957, **37**, 133.
2. SHEPPARD, C. W., and HOUSEHOLDER, A. S., Mathematical basis of interpretation of tracer experiments in closed steady-state systems, *J. Appl. Physics*, 1951, **22**, 510.
3. SOLOMON, A. K., Compartmental methods of kinetic analysis, in *Mineral Metabolism*, (C. L. Comar and F. Bronner, editors) New York, Academic Press, Inc., 1961, **1**, pt. A.
4. BERMAN, M., and SCHOENFELD, R., Invariants in experimental data on linear kinetics and the formulation of models, *J. Appl. Physics*, 1956, **27**, 1361.
- 4a. BERMAN M., and SCHOENFELD, R., A note on unique models in tracer kinetics, *Exp. Cell Research*, 1960, **20**, 574.
5. LEWALLEN, C. G., BERMAN, M., and RALL, J. E., Studies of iodoalbumin metabolism. I. A mathematical approach to the kinetics. *J. Clin. Invest.*, 1959, **38**, No. 1, 66.
6. BRANSON, H., A mathematical description of metabolizing systems; I., *Bull. Math. Biophysics*, 1946, **8**, 159.
- 6a. BRANSON, H., A mathematical description of metabolizing systems: II., *Bull. Math. Biophysics*, 1947, **9**, 93.
7. SCHOENFELD, R. L., and BERMAN, M., An electrical network analogy for isotope kinetics, New York, IRE, 1957 IRE Convention Record, pt. 4, 84.
8. RESCIGNO, A., and SEGRE, G., *La Cinetica Dei Traccianti Radioattivi*. Edizioni Universitarie, Turin, Boringhieri, 1961.
9. STEPHENSON, JOHN L., Theory of transport in linear biological systems: I. Fundamental integral equation, *Bull. Math. Biophysics*, 1960, **22**, 1.
- 9a. STEPHENSON, JOHN L., Theory of transport in linear biological systems: II. Multiflux problems, *Bull. Math. Biophysics*, 1960, **22**, 113.
10. HEARON, J. Z., Rate behavior of metabolic systems, *Physiol. Rev.*, 1952, **32**, No. 4, 499.
- 10a. HEARON, J. Z., A note on the integral equation description of metabolizing systems, *Bull. Math. Biophysics*, 1953, **15**, 269.
11. HART, H. E., Analysis of tracer experiments in nonconservative steady-state systems, *Bull. Math. Biophysics*, June, 1955, **17**, No. 2.
12. SHEPPARD, C. W., *Basic Principles of the Tracer Method*, New York, John Wiley and Sons, Inc., 1962.
13. BERMAN, M., SHAHN, E., and WEISS, M. F., The routine fitting of kinetic data to models: A mathematical formalism for digital computers, *Biophysic. J.*, 1962, **2**, 275.
14. ZILVERSMITH, D. B., ENTENMAN, C., and FISHLER, M. C., Calculation of 'turnover time'

- and 'turnover rate' from experiments involving the use of labeling agents, *J. Gen. Physiol.*, 1943, **26**, 325.
15. SIRI, W. E., Theory of tracer methods, in *Isotopic Tracers and Nuclear Radiations*, New York, McGraw-Hill Book Co., Inc., 1949, chapter 15.
 16. BERMAN, M., Application of differential equations to the study of the thyroid system, *Proc. 4th Berkeley Symp. Mathematical Statistics*, July, 1960, **4**, 87.
 17. BELLMAN, RICHARD, *Stability Theory of Differential Equations*, New York, McGraw-Hill Book Co., Inc., 1953.
 18. SEGAL, S., BERMAN, M., and BLAIR, A., The metabolism of variously C¹⁴ labeled glucose in man and an estimation of the extent of glucose metabolism by the hexose monophosphate pathway. *J. Clin. Invest.*, 1961, **40**, 1263.
 19. BERMAN, M., and WEISS, M. F., unpublished data.
 20. CLYMER, A. B., Direct system synthesis by means of computers, *Tr. Am. Inst. Elec. Eng.*, 1959, 798.
 21. AVIGAN, J., STEINBERG, D., and BERMAN, M., Distribution of labeled cholesterol in animal tissues, *J. Lipid Research*, 1962, **3**, 216.
 22. AYERS, C., DAVIS, J. O., LIEBERMAN, F., CARPENTER, C. C. J., and BERMAN, M., The effects of chronic hepatic venous congestion on the metabolism of D,L-Aldosterone and D-Aldosterone. *J. Clin. Invest.*, 1962, **41**, 884.
 23. TASHJIAN, A. H., JR., and WHEDON, G. D., Citrate kinetics in human bone disease, *46th Ann. Meeting Fed. Am. Soc. Exp. Biol.*, 1962, (abstract).