

## Novel Molecular Variants of the Na-K-2Cl Cotransporter Gene Are Responsible for Antenatal Bartter Syndrome

Rosa Vargas-Poussou,<sup>1</sup> Delphine Feldmann,<sup>2</sup> Martin Vollmer,<sup>4</sup> Martin Konrad,<sup>5</sup> Lisa Kelly,<sup>6</sup> Lambertus P. W. J. van den Heuvel,<sup>7</sup> Lamia Tebourbi,<sup>2</sup> Matthias Brandis,<sup>4</sup> Lothar Karolyi,<sup>5</sup> Steven C. Hebert,<sup>8</sup> Henny H. Lemmink,<sup>7</sup> Georges Deschênes,<sup>3</sup> Friedhelm Hildebrandt,<sup>4</sup> Hannsjörg W. Seyberth,<sup>5</sup> Lisa M. Guay-Woodford,<sup>6</sup> Nine V. A. M. Knoers,<sup>7</sup> and Corinne Antignac<sup>1</sup>

<sup>1</sup>INSERM U423, Necker Hospital, University Paris 5, and Departments of <sup>2</sup>Biochemistry and <sup>3</sup>Pediatric Nephrology, Armand-Trousseau Hospital, Paris; <sup>4</sup>Department of Pediatrics, University of Freiburg, Freiburg, Germany; <sup>5</sup>Department of Pediatrics, Philipps University, Marburg, Germany; <sup>6</sup>Departments of Medicine and Pediatrics, University of Alabama at Birmingham, Birmingham; <sup>7</sup>Departments of Pediatrics and Human Genetics, University Hospital Nijmegen, Nijmegen; and <sup>8</sup>Brigham and Women's Hospital, Harvard Medical School, Boston

### Summary

Antenatal Bartter syndrome is a variant of inherited renal-tubular disorders associated with hypokalemic alkalosis. This disorder typically presents as a life-threatening condition beginning in utero, with marked fetal polyuria that leads to polyhydramnios and premature delivery. Another hallmark of this variant is a marked hypercalciuria and, as a secondary consequence, the development of nephrocalcinosis and osteopenia. We have analyzed 15 probands belonging to 13 families and have performed SSCP analysis of the coding sequence and the exon-intron boundaries of the *NKCC2* gene; and we report 14 novel mutations in patients with antenatal Bartter syndrome, as well as the identification of three isoforms of human *NKCC2* that arise from alternative splicing.

### Introduction

The antenatal hypercalciuric variant of Bartter syndrome, also termed "hyperprostaglandin E syndrome" (Seyberth et al. 1987), is a rare renal-tubular disorder that shares common features (hypokalemia, metabolic alkalosis, and hyperreninemic hyperaldosteronism with normal blood pressure) with the two other types of Bartter syndrome: the classic variant, originally described by Bartter et al. (1962), and the hypocalciuric-hypomag-

nesemic variant, described by Gitelman et al. (1966). Within this relatively rare set of disorders, familial cases occur commonly, and inheritance fits best with autosomal recessive transmission (Hogewind et al. 1981; Schwartz and Alon 1996).

In contrast to classic Bartter syndrome and Gitelman syndrome, the antenatal variant of Bartter syndrome typically presents as a life-threatening disorder that is characterized by both renal-tubular hypokalemic alkalosis and profound systemic manifestations (Seyberth et al. 1985, 1987). Abnormalities begin in utero, with marked fetal polyuria that leads to polyhydramnios and premature delivery (Ohlsson et al. 1984; Proesmans et al. 1985; Seyberth et al. 1985; Deschenes et al. 1993). Affected neonates show severe salt wasting and hyposthenuria, moderate to severe hypokalemic metabolic alkalosis, hyperprostaglandinuria, and failure to thrive. Another hallmark of this variant is a marked hypercalciuria (always >6 mg/kg/d and often >10 mg/kg/d) and, as a secondary consequence, the development of nephrocalcinosis and osteopenia (Fanconi et al. 1971; McCredie et al. 1974; Leonhardt et al. 1992; Shoemaker et al. 1993).

It has been demonstrated that antenatal Bartter syndrome is genetically heterogeneous. Mutations in either the gene encoding the luminal bumetanide-sensitive Na-K-2Cl cotransporter (*NKCC2*) or the gene encoding the luminal ATP-regulated potassium channel, ROMK (*KCJN1*), have been described (Simon et al. 1996a, 1996b; The International Collaborative Study Group for Bartter-Like Syndromes 1997). Recently, mutations in the *CLCNKB* gene, which codes for the basolateral renal chloride channel, ClC-Kb, were identified in patients with the severe neonatal phenotype but also in those with milder forms of Bartter syndrome. The distinguishing feature of this latter group of patients was the absence of nephrocalcinosis, although hypercalciuria was present in 11 of 17 cases (Simon et al. 1997). These genetic data indicate that the molecular pathogenesis of

Received January 5, 1998; accepted for publication April 15, 1998; electronically published May 8, 1998.

Address for correspondence and reprints: Dr. Corinne Antignac, INSERM U423, Hôpital Necker-Enfants Malades, Tour Lavoisier, 6<sup>e</sup> étage, 149 rue de Sèvres, 75743 Paris, France. E-mail: antignac@necker.fr

© 1998 by The American Society of Human Genetics. All rights reserved.  
0002-9297/98/6206-0010\$02.00

**Table 1****Clinical and Biological Characteristics of Index Patients with Antenatal Bartter Syndrome Who Were Not Receiving Indomethacin Therapy**

Subject (Gestational Age [wk])	Polyhydramnios	Iso-/ Hyposthenuria <sup>a</sup>	Hypercalciuria <sup>b</sup>	Nephrocalcinosis <sup>c</sup>	Alkalosis <sup>d</sup>	Hypokalemia and/or Elevated FE <sub>K</sub> <sup>+e</sup>
AB.Paris1 (32)	+	+	+	+	+	+
AB.Paris3.1 (33)	+	+	+	+	+	+
AB.Paris3.2 (26)	+	+	+	+	+	+
AB.Paris8 (32)	+	ND	+	+	+	+
AB.Paris9 (24)	+	+	+	+	+	+
AB.Marb1 (33)	+	+	+	+	+	+
AB.Marb6 (32)	+	+	+	+	+	+
AB.Marb7 (34)	+	ND	+	+	+	+
AB.Marb8 (29)	+	+	+	+	+	+
AB.Marb9 (30)	+	+	+	+	+	+
AB.Marb10 (33)	+	+	+	+	+	+
AB.Marb11 (31)	+	+	+	ND	+	+
AB.Frei1 (unknown)	+	+	+	+	+	+
AB.Frei2.1 (32)	+	+	+	+	+	+
AB.Frei2.2 (39)	+	+	+	+	+	+

NOTE.—A plus sign (+) denotes presence of the characteristic; ND = not determined.

<sup>a</sup> Urine osmolality  $\leq 300$  mosmol/kg, with plasma osmolality  $>290$  mosmol/kg.

<sup>b</sup> Renal calcium excretion  $>0.6$  mg/mg creatinine, or  $>6$  mg/kg/d.

<sup>c</sup> Renal sonographic evidence of nephrocalcinosis.

<sup>d</sup> Serum bicarbonate  $>26$  mmol/liter.

<sup>e</sup> For hypokalemia, serum potassium  $<3.3$  mmol/liter; and, for elevated FE<sub>K</sub><sup>+</sup>, fractional excretion of potassium  $>15\%$ .

Bartter syndrome involves a defect in one of the molecules primarily or secondarily involved in transepithelial chloride transport across the thick ascending limb (TAL).

Interestingly, in the NKCC2 genes of rabbit, mouse, and rat, three isoforms with differential nephron localization have been described. These isoforms differ only by a single 96-bp fragment (corresponding to exon 4), which appears to have arisen from alternative splicing (each variant contains a different version of exon 4) (Payne and Forbush 1994; Igarashi et al. 1995; Yang et al. 1996). This 96-bp exon encodes most of the second transmembrane segment (TM2), which may form part of the ion-translocation pocket. Differences in TM2 in the three isoforms may modify ion binding and ion-affinity determination. Since these isoforms have differential nephron localization, these data could explain the differences in transport characteristics of Na-K-2Cl cotransporters and in regulation of salt transport along the nephron (Payne and Forbush 1995).

Here, we report several novel mutations in the NKCC2 gene that are detected in patients with the antenatal variant of Bartter syndrome, and we describe the characterization of three isoforms of the human NKCC2 gene.

## Patients, Material, and Methods

### Patients

We analyzed 15 patients with antenatal Bartter syndrome who belonged to 13 families (table 1). Index cases from families AB.Paris1, AB.Paris3, AB.Paris8,

AB.Paris9, AB.Marb1, AB.Marb6, AB.Marb8, and AB.Marb10 have been reported elsewhere (Wippermann et al. 1993; Köckerling et al. 1996; The International Collaborative Study Group for Bartter-Like Syndromes 1997). The other cases were identified either in neonatal intensive-care units or in pediatric-nephrology clinics. In family AB.Paris9, DNA from an affected fetus dead in utero at 26 wk gestation was also tested. These studies were approved by local ethics committees, and informed consent was obtained from the probands' parents.

### Genotype Analysis and Haplotype Construction

By standard methods (Knebelmann et al. 1992), genomic DNA was extracted from whole blood of all affected individuals and available family members. Haplotyping was performed with NKCC2-linked markers D15S132, D15S143, D15S123, D15S209, D15S982, D15S126, and D15S121, as reported elsewhere (The International Collaborative Study Group for Bartter-Like Syndromes 1997).

Microsatellite polymorphisms were amplified as described elsewhere (The International Collaborative Study Group for Bartter-Like Syndromes 1997), and amplified products were separated on 6% polyacrylamide gels run under denaturing conditions (Reed et al. 1994). The gels were either analyzed by use of Genescan 672 software (version 1.2) or visualized by autoradiography. Haplotypes were constructed on the basis of the genotype data. The most likely haplotypes were inferred by minimizing the number of crossover events in each sibship.

### Long-Range PCR and Characterization of NKCC2 Isoforms

A human genomic bacterial-artificial-chromosome (BAC) library (Shizuya et al. 1992) was screened by use of a 1.1-kb human genomic PCR product (amplified with primers located in the human NKCC2 cDNA sequence [forward primer ATA GGC CTG ATC TTT GCT TTT and reverse primer GGT CCA CCA TCA TCG AAT CAC]). Three BACs—30M23, 124I1, and 167E12—were obtained and were shown, by PCR amplification, to contain exons 3–5 of the NKCC2 gene. To determine the sequence of the isoforms of exon 4, a sense primer was chosen in exon 3 (34 forward [TGC TCT TCA TTC GCC TCT CC]), and an antisense primer was chosen in exon 5 (34 reverse [ACT CGG GCC CTA AAC TTC TG]), of the published sequence (Simon et al. 1996a). These primers were used to directly amplify the DNA from the three BACs, by long-range PCR (LR-PCR). LR-PCR reactions were performed with the Expand Long Template PCR System Kit (Boehringer Mannheim) as described elsewhere (Rozet et al. 1996). Cycling was performed by use of a Perkin-Elmer GenAmp 9600 Thermocycler. The product obtained was purified with a GeneClean Spin Kit (Bio 101), and direct sequencing was performed by primer walking along the sequence by use of an Applied Biosystems DNA sequencer (model 373A; Perkin-Elmer) and a dideoxy-cycle sequencing protocol (according to the manufacturer's instructions) in the presence of specific primers together with fluorescence-labeled dideoxy terminators.

### PCR and SSCP Analysis

The NKCC2 gene was screened for mobility shifts, by SSCP analysis (Orita et al. 1989). Specific primer pairs that amplify the splice sites and the 26 exons of this gene have been described elsewhere (Simon et al. 1996a). Primer pairs were also chosen to amplify the two additional isoforms of exon 4 (primer pair 4A forward [GCC CGA AGC ATG GAC TGA AA] and 4A reverse [ACC CGT AGC AAG TGA TGA GG] and primer pair 4F forward [GCC TCC TGA AGT ACT GGT GA] and 4F reverse [TTT TGT TTA GGA CAC TGG GG], for isoforms A and F, respectively). PCR reactions were performed in a 25- $\mu$ l volume containing 50 ng of genomic DNA, 1.5 mM MgCl<sub>2</sub>, 10 mM Tris (pH 8.3), 50 mM KCl, 10 pmol of each primer, 0.5 U of *Taq* polymerase, and 0.8  $\mu$ Ci of [ $\alpha$ <sup>32</sup>P]-dCTP. PCR conditions were optimized for the two additional isoforms: after an initial denaturation step at 94°C for 5 min, PCR was conducted for 30 cycles of denaturation at 94°C for 45 s, annealing at 54°C (for isoform A of exon 4) and 58°C (for isoform F of exon 4) for 45 s, and extension at 72°C for 45 s. The reaction was completed with a final elongation step at 72°C for 10 min. Amplified products were analyzed for confor-

mational variants, by electrophoresis on a 0.5 × Hydrolink mutation-detection-enhancement (MDE) non-denaturing gel (AT Biochem) at 4°C, 25°C, or both, in 0.5 × Tris-borate EDTA, at 3–5 W overnight. The gels were dried and exposed to x-ray film for 48–72 h at –80°C. Alternatively, nonradioactive PCR was performed, and gels were silver stained as described elsewhere (Hiort et al. 1994). Identified variants were reamplified, purified on 1.5% agarose gels, and sequenced directly, as described above. In all cases, DNA sequences were confirmed by sequencing of both strands.

## Results

### Antenatal Bartter Syndrome Kindreds

We analyzed 15 patients and 1 fetus belonging to 13 families. In six families (AB.Marb1, AB.Marb7, AB.Paris1, AB.Paris8, AB.Paris9, and AB.Frei1), the affected children were from consanguineous unions. In families AB.Frei2 and AB.Paris3, there were two affected siblings. All index cases had a history of polyhydramnios and premature delivery. Postnatally, patients developed hypokalemic alkalosis, and all had hyposthenuria. Prior to the initiation of indomethacin therapy, all affected infants had failed to thrive, with growth parameters at <3d percentile for their age. Urinary-excretion rates of prostaglandin E2 (PGE2) and/or its major metabolite, prostaglandin E-M (PGE-M), were markedly elevated (100% above upper limit of normal) in all patients in whom these rates were measured. Hypercalciuria with associated sonographic evidence of nephrocalcinosis was demonstrated in all patients. More-detailed clinical features of the patients and laboratory data are given in table 1.

### Genotype Analysis

We were able to determine whether the NKCC2 gene was the disease-susceptibility locus in six families. Markers tightly linked to the NKCC2 locus on chromosome 15 were typed; for example, in families AB.Paris1, AB.Paris8, AB.Paris9, and AB.Marb1, affected offspring of consanguineous unions were homozygous for these markers. In families AB.Paris3 and AB.Frei2, two affected siblings shared the same haplotypes. The haplotypes constructed for these pedigrees suggested linkage between antenatal Bartter syndrome and the NKCC2 locus (fig. 1).

### Characterization of NKCC2 Isoforms

Sequencing of a cDNA, obtained by reverse transcription-PCR from kidney RNA of an affected fetus who died in utero (family AB.Paris9), and of a human cDNA clone (isolated by screening of a human kidney cDNA library with a rat cDNA sequence) showed various se-

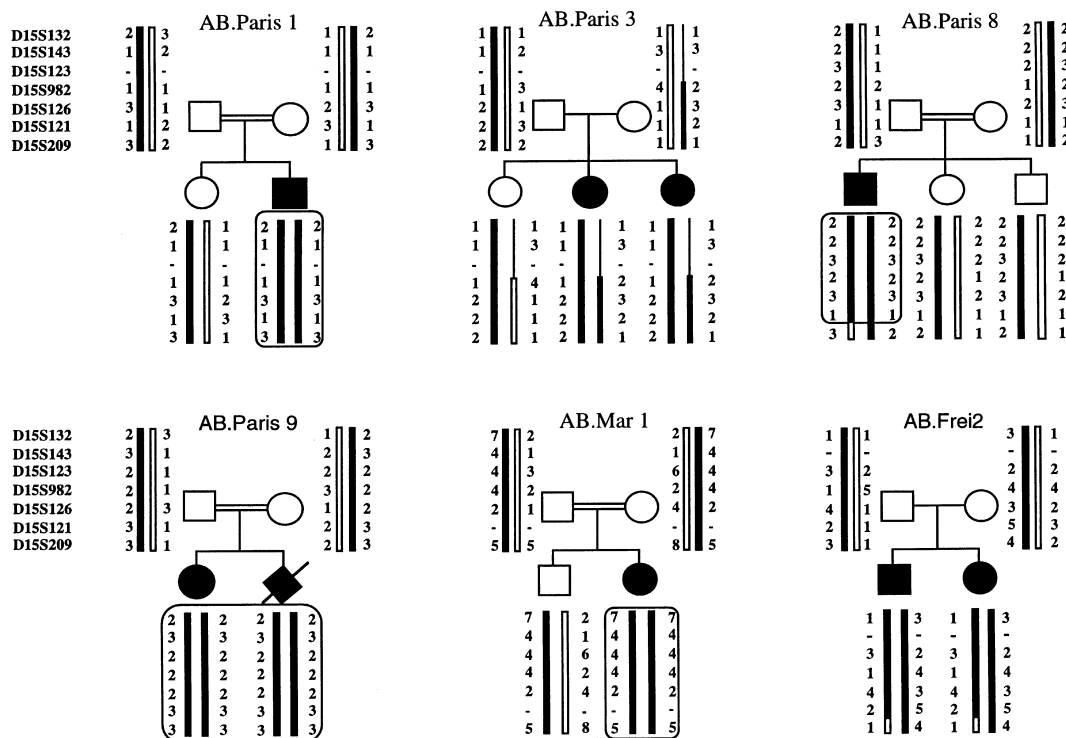

**Figure 1** Pedigrees and haplotypes of antenatal Bartter syndrome families with linkage to the chromosome 15 *NKCC2* interval. Boxes denote regions of homozygosity for marker alleles. The *NKCC2* gene is localized between markers *D5S132* and *D15S209*.

quences at the level of exon 4 (data no shown), raising the possibility of the existence of three isoforms, as already detected in other species. To clarify whether this was the case, the genomic DNA between exon 3 and exon 5 was amplified by use of a sense primer in exon 3 and an antisense primer in exon 5. The LR-PCR amplification product obtained with these primers was ~8.2 kb in size. Direct sequencing and successive database screens of such products showed, in addition to the exon 4 isoform amplified with primers described by Simon et al. (1996a) (which is highly homologous to rabbit, rat, and mouse B isoforms), two alternative exon 4 isoforms, 96 bp in size, that were homologous to the A and F isoforms of these species. Therefore, three isoforms seem to be arising from alternative splicing in the human gene. The order of these cassette exons in genomic DNA is B–A–F. Figure 2 shows the alignment of the deduced amino acid sequences encoded by this 96-bp region from mouse, rat, rabbit, and man. The human amino acid sequences of isoforms A and F are exactly the same as the mouse sequences. It is noteworthy that the nucleotide sequence of exon 4 described by Simon et al. (1996a) differs from the three isoforms presented here, and we could not find this sequence in the 8.2-kb genomic-DNA sequence located between exons 3 and 5. The nucleotide sequences of three isoforms and the adjacent intronic

sequences have been submitted to the GenBank/EMBL Data Bank, with accession number AJ005331-3.

*Mutation Analysis of the NKCC2 Gene*

Sets of primers designed from intronic sequences of *NKCC2* (Simon et al. 1996a), as well as sets of primers chosen for the additional isoforms of exon 4, were used to amplify the coding sequence from genomic DNA of affected individuals. The amplified products were analyzed by SSCP. Aberrant SSCP patterns were detected in eight different exons. The affected children in the consanguineous families were homozygous for these aberrations.

In total, 14 mutations were identified in this cohort of antenatal Bartter syndrome patients, and 7 of them were manifested in the homozygous state. Patients AB.Paris1 and AB.Mar3 have the same mutation. Two patients (AB.Paris3 and AB.Mar3.8) were compound heterozygotes. In four patients, only one heterozygous mutation was found (table 2). Sequence analysis revealed that these mutations are evenly distributed throughout the *NKCC2* gene (fig. 3). In mutation del526N, a 3-bp deletion causes an in-frame deletion of residue 526, which is highly conserved in rabbit, rat, and mouse *NKCC2* sequences and in shark *NKCC1* sequence.

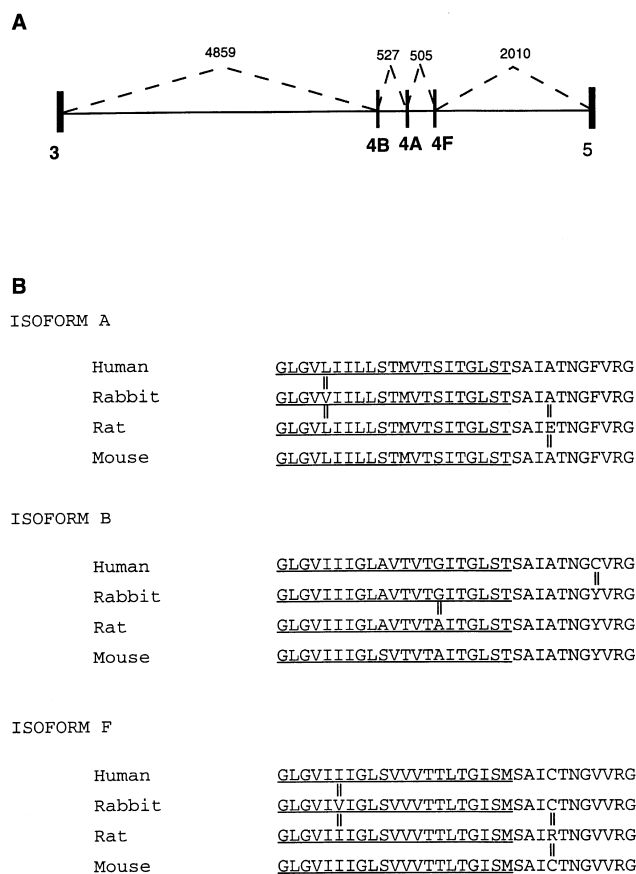

**Figure 2** A, Genomic organization of the three exon 4 isoforms (4B, 4A, and 4F). The vertical lines denote the coding exons, and the thin horizontal line depicts intronic sequences. B, Amino acid sequence alignment of the ABF cassette of exon 4 from man, rabbit, rat, and mouse. Double vertical lines denote positions of amino acids that are not identical in different species. The position of the second transmembrane domain is shown (*underlined*).

Y998X is a nonsense mutation that would lead to a protein lacking the C-terminal 101 residues of the cotransporter protein. In mutation 2135-2136delA, a 1-bp deletion causes a frameshift that does not introduce a stop codon but that modifies the reading frame from codon 706 onward. In mutation 1195delT, a 1-bp deletion causes a frameshift that would result in a truncated protein of 659 amino acids. Ten mutations are missense, causing substitutions of residues that are all highly conserved in rabbit, rat, and mouse *NKCC2* sequences and in shark *NKCC1* sequence.

On the other hand, after our cohort of 31 classic Bartter syndrome patients was screened by SSCP, only one missense mutation in isoform B of exon 4 was found, in a patient with a mild phenotype. This is a boy born at term without polyhydramnios, presenting hypokalemic alkalosis, hyperreninemic hyperaldosteronism, and hypercalciuria without nephrocalcinosis. This pa-

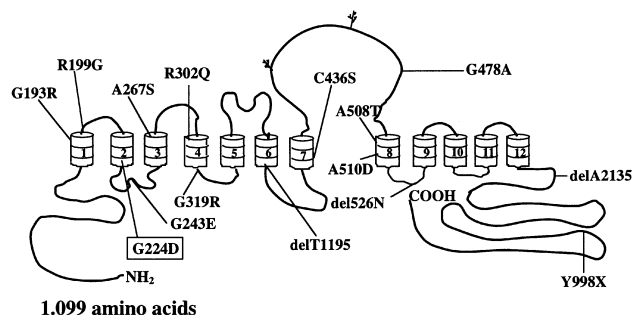

**Figure 3** Model of *NKCC2* cotransporter-protein topology and position of mutations identified in antenatal Bartter syndrome patients. One mutation identified in a patient with classic Bartter syndrome is also indicated (*boxed*).

tient was heterozygous for a CGT→GTA transition at nucleotide 690, which resulted in the substitution of a glycine by an aspartic acid at position 224 (G224D). Exon 4 encodes for TM2, one of the TM domains that displays only a low identity among the different *NKCC* proteins, so that glycine 224 is conserved only in rabbit-*NKCC2* isoform-B protein. No other mutation was found in other *NKCC2* exons of this patient. None of these aberrant SSCP patterns has been observed in examination of ≥50 normal unrelated Caucasian controls (100 test alleles). A silent change generated by a single base substitution (GCG→GCA) at nucleotide 2258 (A752A) was found in patient AB.Paris8.

When DNA was available, familial segregation of mutations was shown. The parents in consanguineous families were shown to be heterozygous for the same mutation, and the parents of compound heterozygotes were heterozygous for one of the two mutations. Two examples are shown in figure 4.

## Discussion

In the normal nephron, the TAL reabsorbs 30% of the filtered NaCl load (Greger 1985). A primary defect in TAL chloride transport could explain the constellation of features evident in Bartter syndrome. Defective TAL chloride transport would result in markedly increased NaCl delivery to the distal nephron, with consequent salt wasting, volume contraction, and stimulation of the renin-angiotensin-aldosterone axis. Increased distal reabsorption via the epithelial sodium channel, coupled with the corresponding increase in potassium and hydrogen secretion in the collecting tubule, would cause hypokalemic metabolic alkalosis. Hypokalemia, chronic volume contraction, and elevated levels of angiotensin stimulate PGE<sub>2</sub> production (Zusman and Keiser 1977, 1980). Elevated PGE<sub>2</sub> inhibits NaCl reabsorption in TAL and stimulates renin production. Suppression of

**Table 2**  
Mutations in the Human NKCC2 Gene in Antenatal Bartter Syndrome

Patient	Ethnic Origin	Homozygous	Nucleotide <sup>a</sup>	Consequence	Exon
		Mutation			
AB.Marb1	Germany	R302Q	CGG→CAG at 924	Arg→Gln at 302	6
AB.Paris9	Mali	G319R	GGA→AGA at 974	Gly→Arg at 319	6
AB.Marb7	Yugoslavia	1195delT	delT at 1195	Frameshift stop at 1318	8
AB.Paris1	Morocco	A508T	GCC→ACC at 1541	Ala→Thr at 508	11
AB.Marb6	Germany	A510D	GCC→GAC at 1548	Ala→Asp at 510	11
AB.Paris8	Algeria	2135–2136delA	delA at 2135/2136	Frameshift at codon 706	16
AB.Frei1	Turkey	del526N	del at 1595–1597	delN526	12
		Heterozygous			
		Mutation			
AB.Paris3	France	G193R	GGA→AGA at 596	Gly→Arg at 193	3
		A267S	GCT→TCT at 818	Ala→Ser at 267	5
AB.Frei2	Belgium	G243E	GGG→GAG at 747	Gly→Glu at 243	5
AB.Marb8	Germany	C436Y	TGT→TAT at 1326	Cys→Ser at 436	10
		R199G	CGC→GGC at 614	Arg→Gly at 199	3
AB.Marb10	Italy	G478R	GGG→AGG at 1451	Gly→Ala at 478	10
AB.Marb9	Germany	A508T	GCC→ACC at 1541	Ala→Thr at 508	11
AB.Marb11	Estonia	Y998X	TAT→TAG at 3013	Tyr→Stop at 998	24

<sup>a</sup> Numbering is according to the sequence numbering of GenBank entry U58130; it corresponds to the nucleotide position plus 19 bases.

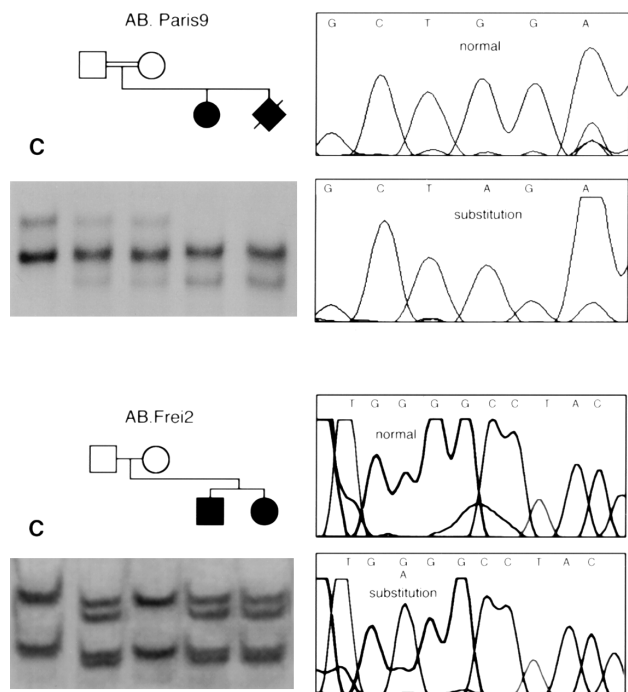

**Figure 4** Segregation of mutations in the NKCC2 gene in two families. In family AB.Paris9, the patient and fetus are homozygous, and their parents are heterozygous, for the mutation. In family AB.Frei2, two siblings and their father are heterozygous for the mutation.

PGE2 formation with cyclo-oxygenase inhibitors such as indomethacin ameliorates many of the clinical and biochemical abnormalities in Bartter syndrome. Until now, the mutations in genes that code for three molecules involved in transepithelial chloride transport across the TAL have been demonstrated: (1) the Na-K-2Cl cotransporter, the major protein involved in salt reabsorption; (2) the potassium-channel ROMK, which recycles potassium back into the lumen and is critical for Na-K-2Cl activity; and (3) the basolateral chloride channel responsible for basolateral exit of chloride.

This study reports the identification of 14 different novel mutations in the NKCC2 gene in 13 families of different ethnic origin that have the antenatal variant of Bartter syndrome. As a group, the mutations reported here lead to either the absence or a dramatic alteration of the protein product. Among the missense mutations, all causing substitution in residues highly conserved among species, 8 of 10 are located either inside the transmembrane domains or in the first two amino acids of the subsequent loop. The transmembrane domains show a very high (>75%) sequence identity between the different NKCC proteins, consistent with the importance of these segments in ion translocation (Payne and Forbush 1995). Although we screened all NKCC2 exons by SCCP, in four patients we identified only one heterozygous disease-causing mutation. Although SCCP screening in this cohort resulted in a mutation-detection

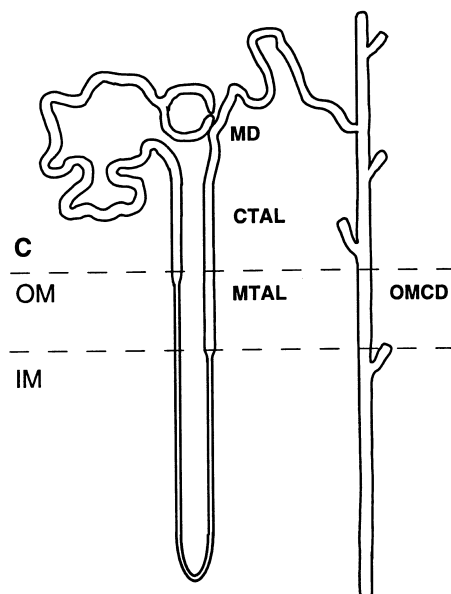

**Figure 5** Schematic diagram of nephron segments. C = cortex; OM = outer medulla; IM = inner medulla; and MD = macula densa (other abbreviations are as given in the text). In the TAL in the species studied, the potential high-capacity, low-affinity Na-K-2Cl cotransporter (isoforms A and F) is localized in the MTAL, and the potential low-capacity, high-affinity Na-K-2Cl cotransporter (isoform B) is localized in the CTAL.

rate of 79%, this methodology has well-documented limitations in sensitivity (Knebelmann et al. 1996). This probably explains our failure to find the second mutation in the four patients. It is notable that all four patients were screened for mutations in *KCNJ1* and *CLCNKB* and that no mutations were found in these genes. Our data add novel mutations to the six previously described by Simon et al. (1996a), confirming that mutations in the bumetanide-sensitive Na-K-2Cl cotransporter underlie the pathogenesis of antenatal Bartter syndrome.

Contrary to the phenotypes observed in patients with mutations in the *CLCNKB* gene, the phenotypes of all of the present cohort are similar, with polyhydramnios and prematurity, severe salt wasting during the neonatal period, severe hypercalciuria, and development of nephrocalcinosis. Furthermore, the available clinical data on these patients are indistinguishable from those for our cohort with *KCNJ1* mutations (The International Collaborative Study Group for Bartter-Like Syndromes 1997).

The identification of alternative human isoforms of NKCC2 is a very interesting observation, which could have important physiological implications. These isoforms arise from alternative splicing of three cassettes of exon 4, resulting in a variable 96-bp sequence that

codes for most of TM2, as well as for 11 amino acids predicted to be intracellular (Payne and Forbush 1994). These three isoforms have differential nephron localization in the species studied. In rabbit, isoform B is almost exclusively expressed in the cortex, isoform F is almost exclusively expressed in the medulla, and isoform A is approximately equally distributed between those two regions (Payne and Forbush 1994). In mouse, isoform B was most highly expressed in the cortical TAL (CTAL), isoform F was most highly expressed in the inner stripe of the outer medulla, and isoform A was most highly expressed in the outer stripe of the outer medulla (Igarashi et al. 1995). Finally, in rat, isoform B is detected exclusively in the CTAL and the macula densa-containing segments (MDCS), isoform F is expressed only in the medullary TAL (MTAL) and the outer-medullary collecting duct, and isoform A is expressed in the CTAL, the MDCS, and the MTAL (Yang et al. 1996). This differential nephron localization may suggest that each isoform is associated with a specific physiological role. Previous studies have shown differences in transport of salt and ammonium between the CTAL and the MTAL, with the MTAL having a higher net transport rate in mouse, rat, and rabbit (Good et al. 1984; Winters et al. 1991). This difference may be the consequence of differential isoform localization. This idea is also supported by data that suggest that the putative TM2 region (which differs between the splice variants) may be involved in ion binding and ion-affinity determination. As proposed by Payne and Forbush (1995), the NKCC2 splice variants may represent a high-capacity, low-affinity cotransporter in the MTAL (isoforms A and F), followed by a low-capacity, high-affinity cotransporter in the CTAL (isoform B) (fig. 5).

The exact localization of NKCC2 isoforms in man is not known, but the high homology with the other species suggests a similar physiological role, and mutations in the low-capacity, high-affinity isoform (isoform B) might explain some of the mild phenotypes of Bartter syndrome. However, after our cohort of Bartter syndrome patients was screened by SSCP, only one heterozygous mutation in isoform B of exon 4 was found, in a patient with a mild phenotype in whom no mutations in the *CLCNKB* gene were found. Functional studies will be required, to establish the involvement of this mutation in the pathogenesis of classic Bartter syndrome.

In summary, we have identified 14 novel mutations in the human NKCC2 gene in patients with the antenatal variant of Bartter syndrome. These findings confirm and extend the initial report by Simon et al. (1996a), which identified NKCC2 as a disease-susceptibility gene in these patients. In addition, we have identified alternative isoforms of human NKCC2. In situ hybridization studies will be necessary to determine the nephron-segment localization of the three human isoforms of the Na-K-2Cl

cotransporter. However, in view of data from other mammalian species that demonstrate differential expression of these isoforms along the distal nephron, our data suggest that mutations involving these human isoforms may cause disease of varying severity.

## Acknowledgments

The authors are indebted to the participating patients and their families, for their cooperation. We would like to thank R. Beetz, E. Bonzel, W. Proesmans, R. Topaloglu, and P. Niaudet, for the contribution of patient material. We thank Dr. Eileen Boye, for critical reading of the manuscript. M.K. and H.W.S. were supported by Deutsche Forschungsgemeinschaft grant Se263/15-1. F.H. and M.V. are additionally supported by Zentrum Klinische Forschung, Freiburg, Germany. The collaborative study group is supported by a Concerted Action, "Identification of the gene defects in Bartter syndrome and Gitelman syndrome," funded by the European Economic Community, within BIOMED II program PL950260. This study was performed in cooperation with the International Study of Genetic Renal Disease.

## Electronic-Database Information

Accession numbers and URLs for data in this article are as follows:

GenBank, <http://www.ncbi.nlm.nih.gov/Web/Genbank> (for isoforms A, B, and F and adjacent intronic sequences [AJ005331-3])

## References

- Bartter FC, Pronove P, Gill JR, MacCardle RC (1962) Hyperplasia of the juxtaglomerular complex with hyperaldosteronism and hypokalemic alkalosis: a new syndrome. *Am J Med* 33:811–828
- Deschenes G, Burguet A, Guyot C, Hubert P, Garabedian M, Déchaux M, Loirat C, et al (1993) Forme anténatale du syndrome de Bartter. *Ann Pediatr* 40:95–101
- Fanconi A, Schachenmann G, Nussli R, Prader A (1971) Chronic hypokalemia with growth retardation, normotensive hyperrenin-hyperaldosteronism (Bartter's syndrome) and hypercalciuria. *Helv Pediatr Acta* 26:144–163
- Gitelman HJ, Graham JB, Welt LG (1966) A new familial disorder characterized by hypokalemia and hypomagnesemia. *Trans Assoc Am Physicians* 79:221–235
- Good DW, Knepper MA, Burg MB (1984) Ammonia and bicarbonate transport by thick ascending limb of rat kidney. *Am J Physiol* 247:F35–F44
- Greger R (1985) Ion transport mechanism in thick ascending limb of Henle's loop of mammalian nephron. *Physiol Rev* 65:760–797
- Hiort O, Wedtke A, Zollmer A, Sinnecke G (1994) Detection of point mutations in the androgen receptor gene using non-isotopic single strand conformation polymorphism analysis. *Hum Mol Genet* 3:1163–1166
- Hogewind B, Van Brummelen P, Veltkamp J (1981) Bartter's syndrome: an autosomal recessive disorder? study of four patients in one generation of the same pedigree and their relatives. *Acta Med Scand* 209:463–467
- Igarashi P, Vanden Heuvel GB, Payne JA, Forbush B (1995) Cloning, embryonic expression, and alternative splicing of a murine kidney-specific Na-K-Cl cotransporter. *Am J Physiol* 269:F405–F418
- International Collaborative Study Group for Bartter-Like Syndromes, The (1997) Mutations in the gene encoding the inwardly-rectifying renal potassium channel, ROMK, cause the antenatal variant of Bartter syndrome: evidence for genetic heterogeneity. *Hum Mol Genet* 6:17–26
- Knebelmann B, Breillat C, Forestier L, Arrondel C, Jacassier D, Giatras I, Drouot L, et al (1996) Spectrum of mutations in the COL4A5 collagen gene in X-linked Alport syndrome. *Am J Hum Genet* 59:1221–1232
- Knebelmann B, Deschenes G, Gros F, Hors M-C, Grünfeld J-P, Tryggvason K, Gubler M-C, et al (1992) Substitution of arginine for glycine 325 in the collagen  $\alpha 5(IV)$  chain associated with X-linked Alport syndrome: characterization of the mutation by direct sequencing of PCR-amplified lymphoblast cDNA fragments. *Am J Hum Genet* 51:135–142
- Köckerling A, Reinalter S, Seyberth H (1996) Impaired response to furosemide in hyperprostaglandin E syndrome: evidence for a tubular defect in the loop of Henle. *J Pediatr* 129:519–528
- Leonhardt A, Timmermanns G, Roth B, Seyberth H (1992) Calcium homeostasis and hypercalciuria in hyperprostaglandin E syndrome. *J Pediatr* 120:546–554
- McCredie DA, Rotenberg E, Williams AL (1974) Hypercalciuria in potassium-losing nephropathy: a variant of Bartter's syndrome. *Aust Paediatr J* 10:286–295
- Ohlsson A, Sieck U, Cumming W, Akhtar M, Serenius F (1984) Bartter syndrome associated with hydramnios prematurity, hypercalciuria and nephrocalcinosis. *Acta Pediatr Scand* 73:868–874
- Orita M, Suzuki YH, Sakiya T, Hayashi K (1989) Rapid and sensitive detection of point mutations and DNA polymorphisms using the polymerase chain reaction. *Genomics* 5:874–879
- Payne JA, Forbush B (1994) Alternatively spliced isoforms of the putative renal Na-K-Cl cotransporter are differentially distributed within the rabbit kidney. *Proc Natl Acad Sci USA* 91:4544–4548
- (1995) Molecular characterization of the epithelial Na-K-Cl cotransporter isoforms. *Curr Opin Cell Biol* 7:493–503
- Proesmans W, Devlieger H, Assche AV, Eggermont E, Vandenbergh K, Lemmens F, Sieprath P, et al (1985) Bartter syndrome in two siblings—antenatal and neonatal observations. *Int J Pediatr Nephrol* 6:63–70
- Reed PW, Davies JL, Copeman JB, Bennet ST, Palmer SM, Pritchard LE, Gough SLC, et al (1994) Chromosome-specific microsatellite sets for fluorescence-based, semi-automated genome mapping. *Nat Genet* 7:390–395
- Rozet JM, Gerber S, Perrault I, Camuzat A, Calvas P, Viegas-Pequinot E, Molina-Gomes D, et al (1996) Structure and physical mapping of DR1, a TATA-binding protein-associated phosphoprotein gene, to chromosome 1p22.1 and its



- exclusion in Stargardt disease (STGD). *Genomics* 36: 554-556
- Schwartz I, Alon U (1996) Bartter syndrome revisited. *J Nephrol* 9:81-87
- Seyberth HW, Königer SJ, Rascher W, Kühl PG, Schweer H (1987) Role of prostaglandins in hyperprostaglandin E syndrome and in selected renal tubular disorders. *Pediatr Nephrol* 1:491-497
- Seyberth HW, Rascher W, Schweer H, Kuhl P, Mehls O, Schärer K (1985) Congenital hypokalemia with hypercalciuria in preterm infants: a hyperprostaglandinuric tubular syndrome different from Bartter syndrome. *J Pediatr* 107: 694-701
- Shizuya H, Birren B, Kim UJ, Mancino V, Splepak T, Tachiiri Y, Simon M (1992) Cloning and stable maintenance of 300-kb fragments of human DNA in *Escherichia coli* using F-factor-based vector. *Proc Natl Acad Sci USA* 89:8794-8797
- Shoemaker L, Welch T, Bergstrom W, Abrams S, Yergey A, Vieira N (1993) Calcium kinetics in the hyperprostaglandin E syndrome. *Pediatr Res* 33:92-96
- Simon D, Bindra RS, Mansfield TA, Nelson-Williams C, Mendoca E, Stone R, Schurman S, et al (1997) Mutations in the chloride channel gene, *CLCNKB*, cause Bartter's syndrome type III. *Nat Genet* 17:171-178
- Simon D, Karet F, Hamdan J, DiPietro A, Sanjad S, Lifton R (1996a) Bartter's syndrome, hypokalemic alkalosis with hypercalciuria, is caused by mutations in the Na-K-2Cl cotransporter *NKCC2*. *Nat Genet* 13:183-188
- Simon D, Karet F, Rodriguez-Soriano J, Hamdan J, DiPietro A, Trachtman H, Sanjad S, et al (1996b) Genetic heterogeneity of Bartter's syndrome revealed by mutations in the  $K^+$  channel, *ROMK*. *Nat Genet* 14:152-156
- Winters CJ, Reeves WB, Andreoli TE (1991) A survey of transport properties of the thick ascending limb. *Semin Nephrol* 11:236-247
- Wippermann CF, Huber A, Beetz R, Baum V, Stopfkuchen H (1993) Polyhydramnios caused by fetal hyperprostaglandin E syndrome, a variant of Bartter's syndrome: case report and review of the literature. *J Matern Fetal Invest* 3:91-93
- Yang T, Huang YG, Singh I, Schnermann J, Briggs JP (1996) Localization of bumetanide- and thiazide-sensitive Na-K-Cl cotransporters along the rat nephron. *Am J Physiol* 271: F931-F939
- Zusman R, Keiser H (1977) Prostaglandin biosynthesis by rabbit renomedullary interstitial cells in tissue culture: stimulation by angiotensin II, bradykinin and arginine vasopressin. *J Clin Invest* 60:215-223
- (1980) Regulation of prostaglandin E<sub>2</sub> synthesis by angiotensin II, potassium, osmolality, and dexamethasone. *Kidney Int* 17:277-283