

# Selective deficiency of pancreatic amylase

K Sjölund, A Häggmark, I Ihse, G Skude, U Kärnström, M Wikander

## Abstract

Two patients with specific pancreatic amylase deficiency are described. The greatly reduced pancreatic amylase activity was not due to an enzymatically inactive amylase molecule but to an almost complete absence of the molecule itself. The findings are of diagnostic importance as they show that low pancreatic amylase activity in serum or duodenal aspirates, or both, does not necessarily represent chronic exocrine pancreatic disease such as chronic pancreatitis, carcinoma of the pancreas, or cystic fibrosis but may be an isolated finding. In one of our patients a familial occurrence was shown, indicating a congenital deficiency.

Isolated deficiency of lipolytic or proteolytic pancreatic enzymes has been described previously,<sup>1-4</sup> whereas deficiency of pancreatic amylase has been reported only in combination with reduced lipolytic and proteolytic activities.<sup>5-7</sup> In young children physiologically low levels of pancreatic amylase activity is recognised.<sup>8-11</sup> The adult level of pancreatic amylase activity in the duodenal juice is reached at the age of 18 months<sup>12</sup> and in serum at about age 7 years,<sup>13</sup> although delayed maturation has been described.<sup>14,15</sup> In adults little is known about the existence of selective amylase deficiency. Borgström and Wehlin have reported a deficiency of pancreatic amylase activity in plasma in two women with a normal trypsin activity and normal endoscopic retrograde pancreatography.<sup>16</sup> Familial occurrence of selectively diminished pancreatic serum amylase activity has recently been reported by Brock *et al*<sup>17</sup> and Jørgensen *et al*.<sup>18</sup> Unfortunately, they did not measure lipolytic enzymes in serum or pancreatic enzyme activity in duodenal aspirate. We report two cases of documented specific and probably congenital pancreatic amylase deficiency.

## Patient 1

A 49 year old woman was referred because of epigastric distress, meteorismus, and severe increasing constipation over many years. During the previous three years she also had been depressed and required continuous treatment with tricyclic antidepressants. Thorough diagnostic investigations showed no somatic abnormalities. Repeated determinations of serum isoamylase activity showed appreciably reduced activity of pancreatic amylase (6 U/l, reference value 50-300 U/l),<sup>19</sup> while salivary amylase activity was normal. Duodenal aspirates obtained after stimulation with a Lundh test meal<sup>20</sup> showed low pancreatic amylase activity - about 0.2% compared with that of a control group (Fig 1).<sup>21</sup>

After agarose gel electrophoresis the isoamy-

lase fractions of the duodenal aspirates were visualised using incubation with an insoluble dye-starch polymer. In this way the electrophoretic fractions containing amylase activity were detected. As Figure 2A shows the pancreatic isoamylase activities of the various samples were extremely low, indeed as low as or lower than salivary isoamylase activity. The various amylase fractions of the duodenal aspirates were also shown using rabbit antiserum against human amylase. With this immunofixation, weak fractions showing antigenic similarity to human amylase were found in the aspirates (Fig 2B). Thus it can be concluded that the reduced pancreatic amylase activity in the patient is not due to an enzymatically inactive molecule showing great similarities to normal human amylase. Protein staining of the various samples showed no distinct protein bands (Fig 2C). The greatly reduced pancreatic amylase activity therefore is explained by an almost complete lack of pancreatic amylase molecules.

The activity of trypsin and the content of lipase in the duodenal juice were normal as was lipase content in serum (30 µg/l, reference value 7-56 µg/l). The lipase content in serum was measured immunochemically (Enzygnost lipase, Hoechst-Behringwerke) and the same method was used in duodenal aspirates after dilution of the samples. Duodenal trypsin activity was assayed according to Hummel.<sup>22</sup>

The patient denied regular or excessive alcohol consumption. She had no history suggesting gall bladder disease nor a history of pancreatitis. The

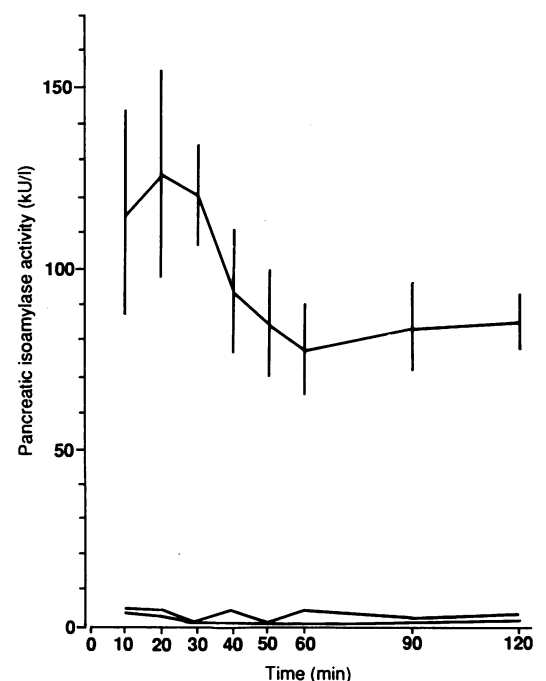

Figure 1: The activity of pancreatic isoamylase in duodenal aspirates from the two patients (bottom) and from a reference group (top) (means (SEM) are indicated).<sup>17</sup>

Department of Internal Medicine, General Hospital, University of Lund, Malmö  
K Sjölund

Department of Clinical Chemistry, Karolinska Institute, South Hospital, Stockholm  
A Häggmark

Department of Surgery, University Hospital, Linköping  
I Ihse

Department of Clinical Chemistry, County Hospital, Kalmar  
G Skude

Department of Clinical Chemistry, Helsingborg Hospital, Helsingborg  
U Kärnström

Department of Internal Medicine, Landskrona Hospital, Landskrona, Sweden  
M Wikander

Correspondence to:  
Dr K Sjölund, Department of Internal Medicine, General Hospital, University of Lund, S-214 01 Malmö, Sweden.

Accepted for publication  
3 July 1990

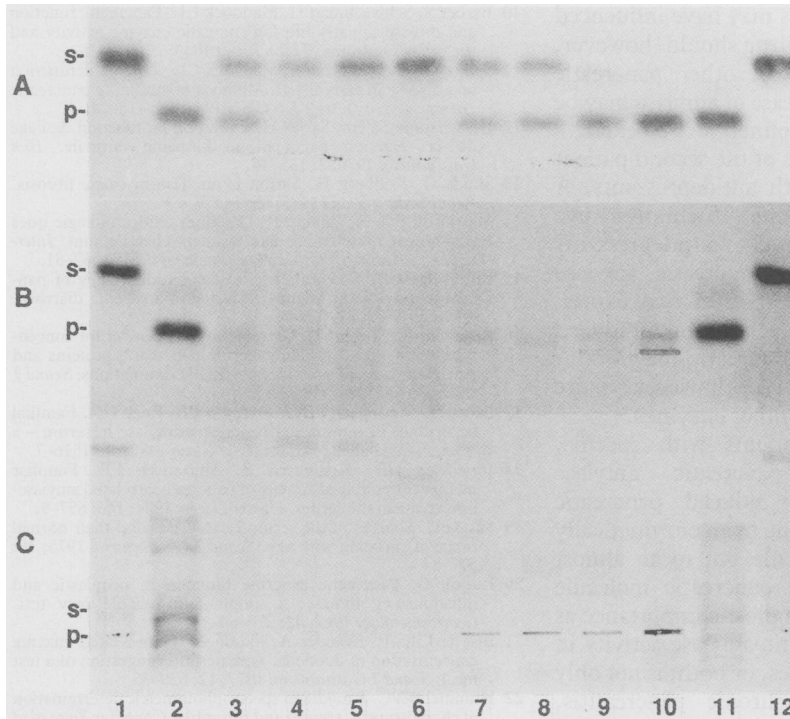

Figure 2: Electrophoretic patterns of the eight samples of duodenal aspirates obtained after a Lundh test of patient 1 compared with saliva and pancreatic juice from control subjects. Samples 1 and 12: reference samples of normal saliva. Samples 2 and 11: reference samples of normal pancreatic juice. Sample 3-10: the sequential samples of duodenal aspirates from the patient. s=main salivary isoamylase; p=main pancreatic isoamylase fraction. (A) Amylase activity is shown after incubation with a dye-starch polymer. In patient 1 there is an absence of staining of pancreatic amylase in samples 4-6 and faint staining in samples 3, 7-9. (B) The presence of amylase is shown after incubation with antibodies directed against human amylase. In the patient a weak immunoreactivity is seen mainly in sample 10. (C) The protein fractions are shown only after protein staining. For the patient no distinct protein staining corresponding to pancreatic amylase is seen in the different samples.

family history could not be traced as she had been adopted and did not know her biological parents. There were no clinical or laboratory signs of malabsorption (normal serum concentrations of albumin, ferritin, calcium, vitamin, B<sub>12</sub>, and folic acid and normal excretion of faecal fatty acids). An oral glucose tolerance test and the sodium/chloride concentration in sweat was normal. Pancreatic enzyme supplementation had no effect on her symptoms.

**Patient 2**

A 38 year old woman was previously healthy except for depression requiring short treatments with tricyclic antidepressants. Due to loose

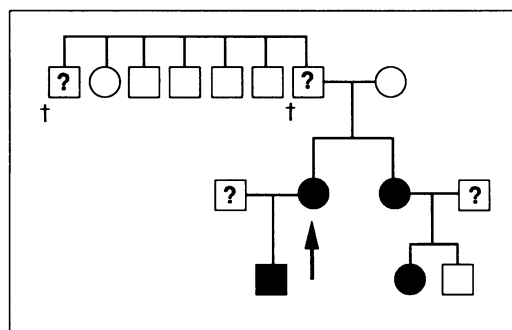

Figure 3: Pedigree of patient 2. Open symbols represent family members with normal pancreatic amylase activity, closed symbols represent those with abnormally low activities, and question marks denote those not studied. The arrow indicates the patient.

stools, determination of serum isoamylases were performed. Pancreatic amylase activity in serum was greatly reduced (<5 U/l). Serum lipase activity was normal. Duodenal aspirate after stimulation with a Lundh test meal showed a reduced content of pancreatic amylase (about 17% of normal content in the first samples and about 3% in the last) (Fig 1). The lipase content was normal. Measurements of immunoreactive amylase in serum and duodenal aspirate showed similar changes as in the first patient – that is, deficiency of the pancreatic amylase protein and not only enzymatic activity.

To find out whether there was a hereditary disorder the relatives were examined (Fig 3). The patient's father was dead but his four brothers and one sister were tested. They all had normal serum pancreatic amylase and lipase activities. Furthermore, the patient's mother had normal serum amylase activity. Reduced activities were, however, found in her only sister (6 U/l) and her only son aged 8 years (<5 U/l). The patient's sister had two children, a girl and a boy. The girl had slightly reduced pancreatic amylase activity in serum (40 U/l).

**Discussion**

Our two cases illustrate isolated deficiency of pancreatic amylase in serum and duodenal aspirates with normal trypsin and lipase activities. In physiological amylase deficiency in children due to delayed maturation there may be symptoms of starch maldigestion with fermentative diarrhoea, which disappear with a starch free diet.<sup>14</sup> One of our patients had a short period of diarrhoea, which disappeared without her changing her diet. Complete digestion and absorption of starch probably require small amounts of amylase.<sup>23</sup> Normally, the salivary amylase will be sufficient for starch digestion.

In adults a reduced serum amylase activity usually represents generally impaired pancreatic function secondary to pancreatic disease such as chronic pancreatitis.<sup>24-26</sup> The reduced activity of pancreatic amylase is then accompanied by sub-normal trypsin and lipase activity in duodenal aspirates. Reduced pancreatic amylase activity may also occur in other conditions with a disturbed pancreatic function, such as carcinoma of the pancreas,<sup>24</sup> cystic fibrosis,<sup>13</sup> haemochromatosis, and severe protein malnutrition.<sup>27</sup> Among patients who have undergone gastric resection a high percentage show decreased activities of chymotrypsin, amylase, and lipase in intestinal contents.<sup>4</sup> This is probably caused by a disturbed stimulation of the pancreatic secretion.

Impairment of exocrine pancreatic function may occur in patients with insulin dependent diabetes. Kamaryt *et al*<sup>28</sup> found this more often in young diabetics than in those who developed the disease after age 25. The decrease in amylase activity was reported to be parallel to the impairment of the endocrine function in one study<sup>29</sup> but not in another.<sup>30</sup> One of our patients had a normal glucose tolerance test.

Both patients have been treated with tricyclic antidepressants. Cholinergic mechanisms are important for the regulation and stimulation of pancreatic secretion. The anticholinergic effect

of tricyclic antidepressants may have influenced pancreatic secretion. The drug should, however, also affect the secretion of other pancreatic enzymes, although the release of amylase may be more sensitive to cholinergic blockade.<sup>31</sup> Furthermore, the relatives of the second patient had not been treated with antidepressants. A group of children and adults (10 children, five adults) treated with tricyclic antidepressants showed no reduction in pancreatic amylase activity (unpublished results). In two experimental studies repeated alcohol intake reduced the secretion of different pancreatic enzymes.<sup>32,33</sup> The amylase secretion was, however, more depressed than that of the other enzymes.

We described two patients with specific, probably congenital, pancreatic amylase deficiency. The greatly reduced pancreatic amylase activity was not due to an enzymatically ineffective amylase molecule but to an almost complete absence of the pancreatic molecule itself. The finding is of diagnostic importance as it shows that low pancreatic amylase activity in serum or duodenal aspirates, or both, is not only seen in patients with chronic pancreatitis, carcinoma of the pancreas, cystic fibrosis, and after gastric resection but can occur as an isolated finding. In one patient we were able to show a familial occurrence of the selective deficiency of pancreatic amylase.

- 1 Sheldon W. Congenital pancreatic lipase deficiency. *Arch Dis Child* 1964; 39: 268-71.
- 2 Rey J, Frezal J, Royer P, Lamy M. L'absence congénitale de lipase pancréatique. *Arch Fr Pédiatr* 1966; 23: 5-14.
- 3 Hildebrand H, Erlanson-Albertson C, Borgström B, Becassy A, Helin I. Isolated colipase deficiency in two brothers. *Gut* 1982; 23: 243.
- 4 Arnesjö B, Ihse I, Odeberg H, Ståhl E. Deficiency of lipolytic pancreatic enzymes in an adult man. *Digestion* 1974; 11: 147-51.
- 5 Morris MD, Fischer DA. Trypsinogen deficiency disease. *Am J Dis Child* 1967; 114: 203-8.
- 6 Townes PL, White MR. Identity of two syndromes. Proteolytic, lipolytic and amylolytic deficiency of the exocrine pancreas with congenital anomalies. *Am J Dis Child* 1981; 135: 248-50.
- 7 Lowe CU, May CD. Selective pancreatic deficiency: absent amylase, diminished trypsin and normal lipase. *Am J Dis Child* 1951; 82: 459-64.
- 8 Andersen D. Pancreatic enzymes in duodenal juice in celiac syndrome. *Am J Dis Child* 1942; 63: 643-58.
- 9 Klumpp TG, Neale AV. Gastric and duodenal contents of normal infants and children; duodenal enzyme activities and gastric reactions. *Am J Dis Child* 1930; 40: 1215-29.
- 10 Farber S, Schwachman H, Maddock CL. Pancreatic function and disease in early life I. Pancreatic enzyme activity and the celiac syndrome. *J Clin Invest* 1943; 22: 827-38.
- 11 Schwachman H, Farber S, Maddock CL. Pancreatic function and disease in early life II. Methods of analyzing pancreatic enzyme activity. *Am J Dis Child* 1943; 66: 418-24.
- 12 Delachaux-Salem, Sarles H. Evolution en fonction de l'âge de la sécrétion pancréatique humaine normale. *Biol Gastroenterol* 1970; 2: 135-46.
- 13 Skude G, Kollberg H. Serum isoamylase in cystic fibrosis. *Acta Paediatr Scand* 1975; 65: 145-9.
- 14 Martin du Pan R, Infante R. Quelques études biologiques concernant l'intolérance aux farineux chez l'enfant. *Internationale Zeitschrift für Vitamin-forschung* 1961; 1: 67-81.
- 15 Lillibridge CB, Townes PL. Physiologic deficiency of pancreatic amylase in infancy; a factor in atrogenic diarrhea. *J Pediatr* 1973; 82: 279-82.
- 16 Borström A, Wehlin L. Correlation between serum concentrations of three specific exocrine pancreatic proteins and pancreatic duct morphology at ERCP examinations. *Scand J Gastroenterol* 1984; 19: 220-7.
- 17 Brock A, Mortensen PB, Mortensen BB, Roge HR. Familial occurrence of diminished pancreatic amylase in serum - a 'silent' amy-2 allelic variant? *Clin Chem* 1988; 34: 1516-7.
- 18 Jørgensen HR, Kristensen B, Mortensen PB. Familial incidence of reduced activity of pancreas-correlated amylase-isoenzyme in the serum. *Ugeskr Laeger* 1984; 146: 657-9.
- 19 Skude G. Sources of the serum isoamylases and their normal range of variation with age. *Scand J Gastroenterol* 1975; 10: 577-84.
- 20 Lundh G. Pancreatic exocrine function in neoplastic and inflammatory disease; a simple and reliable new test. *Gastroenterology* 1962; 42: 275-80.
- 21 Ihse I, Lilja P, Evander A, Skude G. Time-related enzyme concentration in duodenal aspirates after ingestion of a test meal. *Scand J Gastroenterol* 1977; 12: 629-35.
- 22 Hummel BWC. A modified spectrophotometric determination of chymotrypsin, trypsin and thrombin. *Canadian Journal of Biochemistry and Physiology* 1959; 37: 1393-9.
- 23 Fogel MR, Gray GM. Starch hydrolysis in man: an intraluminal process not requiring membrane digestion. *J Appl Physiol* 1973; 55: 263-7.
- 24 Skude G, Ihse I. Isoamylase in pancreatic carcinoma and chronic relapsing pancreatitis. *Scand J Gastroenterol* 1977; 12: 53-7.
- 25 Taussig L, Wolf R, Woods R, Deckelbaum R. Use of serum isoamylase isoenzymes in evaluation of pancreatic function. *Pediatrics* 1974; 54: 229-35.
- 26 Skude G, Ericsson S. Serum isoamylases in chronic pancreatitis. *Scand J Gastroenterol* 1976; 11: 525-7.
- 27 Fedail S, Karar ZA, Harvey EF, Read AE. Serum trypsin as a measure of pancreatic exocrine function in children with protein calorie malnutrition. *Lancet* 1980; ii: 374.
- 28 Kamaryt J, Laxova R. Amylase heterogeneity. Some genetic and clinical aspects. *Humangenetik* 1965; 1: 579-86.
- 29 Skrha J, Stephan J, Havranek T, et al. Isoamylases in diabetes mellitus. *Diabetologia* 1981; 20: 129-33.
- 30 Lankisch PG, Mathey G, Otto J, et al. Exocrine pancreatic function in insulin-dependent diabetes mellitus. *Digestion* 1982; 25: 211-6.
- 31 Meullenet J, Baratta H, Sarles H. Alcohol et anticholinergiques. Effets sur la sécrétion pancréatique exocrine de l'homme. *Gastroenterol Clin Biol* 1979; 3: 885-92.
- 32 Bossekert H, Winnerfeld K, Thieme E. Changes in protein and calcium spectrum in pancreatic homogenates after short-time alcoholic charge. *Digestion* 1985; 32: 168.
- 33 Bode C, Durr HK, Bode JC. Effects of short and long-term alcohol feeding in rats on pancreatic enzyme content and enzyme secretion in isolated pancreatic lobules in vitro. *Int J Pancreatol* 1986; 1: 129-39.