

Long-Term Continuous Cultivation of *Clostridium beijerinckii* in a Two-Stage Chemostat with On-Line Solvent Removal

JAMES RICHARD GAPES,* DRAGAN NIMCEVIC, AND ANTON FRIEDL

Institute of Chemical Engineering, Fuel Technology and Environmental Technology, University of Technology Vienna, 1060 Vienna, Austria

Received 25 January 1996/Accepted 19 March 1996

A two-stage continuous cultivation experiment with *Clostridium beijerinckii* NRRL B592 is described. This strain maintained its ability to produce neutral solvents (acetone, *n*-butanol, and ethanol) at an overall dilution rate of 0.13 h⁻¹ and achieved an average overall solvent concentration of 9.27 g/liter and an overall solvent productivity of 1.24 g/liter/h for more than 100 overall retention times. The experiment was performed without pH control on a semisynthetic medium containing yeast extract, and product inhibition was the limiting factor. Solid carrier material was present in both stages, and the solvent productivity in both stages was similar. A membrane evaporation module integrated into the recirculation loop of a second-stage bioreactor after 2,166 h increased solvent productivity and improved the yield of solvents by about 40%. The membrane reduced the concentration of solvents, which would otherwise inhibit the fermentation. Additionally, the integrated membrane evaporation dampened metabolic oscillations, which are characteristic of continuous cultivation of clostridia. It was also demonstrated that a moderate concentration buildup (approximately 30% of bioreactor inflow) caused by water flux through the membrane caused no detrimental effects to the bacterial cells. However, much higher water fluxes through the membrane, associated with a much more dramatic increase in the concentration of salts in the medium, did appear to favor cell degeneration.

The recently revived interest in microbial production of acetone and *n*-butanol is based almost exclusively on investigations with saccharolytic clostridial strains. Most of the strains used were designated *Clostridium acetobutylicum*, while some other strains, e.g., *Clostridium beijerinckii* and *Clostridium butylicum*, were also used. Recently conducted studies of solvent-producing clostridial strains showed, however, that the nomenclature of these strains requires revision. For example, it was shown that the strains designated *C. butylicum* are actually members of *C. beijerinckii* (13). Furthermore, it was found that *C. acetobutylicum* NCIMB 8052 should also be designated *C. beijerinckii* (18) and that *C. acetobutylicum* P262 should be distinguished from other *C. acetobutylicum* strains (19).

C. beijerinckii strains are capable of producing a mixture of neutral solvents consisting either of isopropanol, *n*-butanol, and ethanol or of (in those strains lacking isopropanol dehydrogenase) acetone, *n*-butanol, and ethanol (38). Similar to *C. acetobutylicum* strains, *C. beijerinckii* is able to ferment a variety of sugars and to produce neutral solvents; the solvents are produced at slightly higher concentrations than in *C. acetobutylicum* (32).

Experiments with *C. beijerinckii* LMD 27.6 have, however, demonstrated difficulties in maintaining stable continuous cultures over a prolonged period, because of a shift to acid production (17). Furthermore, batch experiments with *C. beijerinckii* strains have been shown to undergo degeneration after just three subcultures without being heat shocked (11, 23). Degeneration also occurs in *C. acetobutylicum* strains, as a result of progressive overgrowth by phenotypic variants which lack the ability to produce solvents and to sporulate (22). These strains have shown differences in their ability to main-

tain solvent production in continuous culture (37). Repeated subculturing of *C. acetobutylicum* ATCC 824 resulted in slow degeneration, which was overcome after doubling of the inoculum volume (16). Experiments with *C. acetobutylicum* ATCC 824 involving continuous culture and without continuous removal of a portion of the cell population appeared to display a slower drift to degeneration (26). The degeneration-resistant mutant of *C. acetobutylicum* NCIMB 8052 (actually *C. beijerinckii* NCIMB 8052) showed an approximately fourfold increase in resistance to degeneration compared with its parent strain (22).

Even healthy cultures of solvent-producing clostridia in continuous cultivation yield low final concentrations of solvents and low volumetric solvent productivities. The productivity of continuous cultivation can be increased to values between 0.5 and 1.0 g/liter/h in a culture of freely suspended cells (24). Modest increases in productivity can be achieved by increasing the cell concentration in medium. Several such methods are described in the literature, e.g., cell recycling by means of cross-flow microfiltration (6), special construction of the bioreactor (26), and cell immobilization on alginate beads (33) or bone char (28). The use of carrier material and formation of cell aggregates has also been described as a useful method to increase the biomass concentration and therefore the productivity of microbial process (1). Several solids have been successfully tested as carrier materials during both batch and continuous cultivation of *C. acetobutylicum* (35). The use of an aggregate-forming variant of *n*-butanol-producing bacteria has also been described, and solvent productivities of 2.1 g/liter/h in a chemostat culture have been reported (39).

It is well known that the final concentration of solvents in a batch culture is limited to about 20 g/liter and that the final concentration in a continuous culture is often lower, depending on the culture conditions applied. Those low concentrations of solvents are caused by product inhibition (20) and result in high costs of solvent recovery in industrial plants. Several techniques for on-line product removal have been in-

* Corresponding author. Mailing address: Institute of Chemical Engineering, Fuel Technology and Environmental Technology, University of Technology Vienna, Getreidemarkt 9/159, 1060 Vienna, Austria. Phone: 43/1/58801-4713. Fax: 43/1/587 63 94. Electronic mail address: rgapes@fbch.tuwien.ac.at.

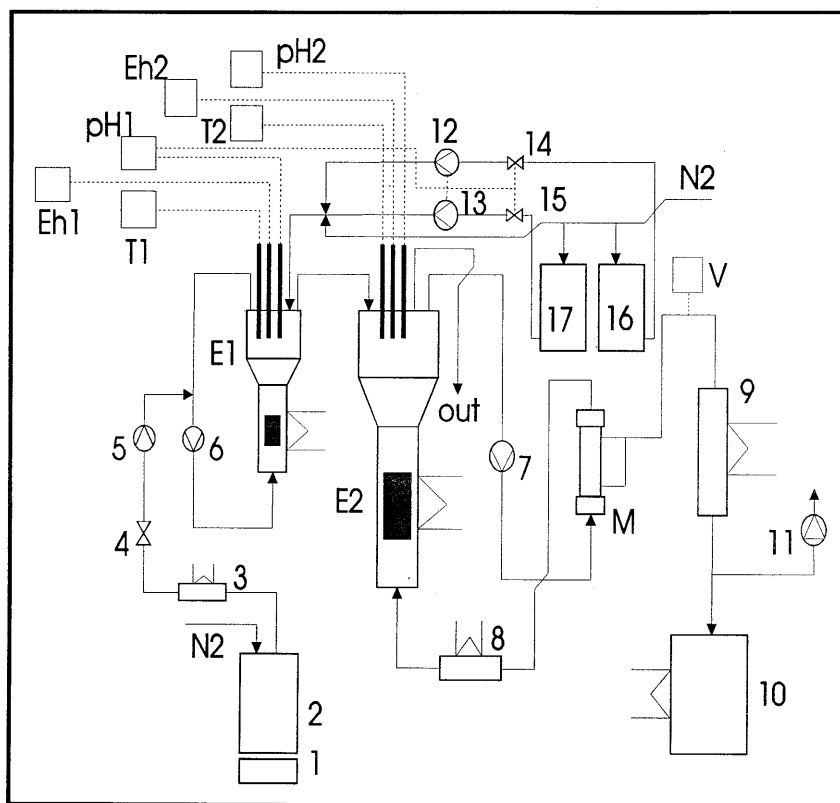

FIG. 1. Experimental setup of a two-stage continuous acetone-butanol-ethanol fermentation with on-line product removal. The components of the setup are designated as follows: 1, balance; 2, feed tank; 3, heat exchanger; 4, feed regulation valve; 5, feed pump; 6, first-stage recirculation pump; E1, first-stage tower bioreactor; E2, second-stage tower bioreactor; 7, second-stage recirculation pump; M, membrane evaporation module; 8, heat exchanger; 9, condenser; 10, condensate tank; 11, vacuum pump; 12, alkali feed pump; 13, acid feed pump; 14, alkali dosing regulation valve; 15, acid dosing regulation valve; 16, alkali tank; 17, acid tank; T1, first-stage temperature recorder; Eh1, first-stage redox recorder; pH1, first-stage pH recorder and controller; T2, second-stage temperature recorder; Eh2, second-stage redox recorder; pH2, second-stage pH recorder; V, vacuum recorder; N2, nitrogen feed.

vestigated to reduce the effect of *n*-butanol toxicity, to enhance the productivity of solvents, to make the utilization of sugar more complete, and to concentrate the solvents produced prior to distillation. Liquid-liquid extraction (4, 30, 31), gas stripping (29, 30), pertraction (30, 34), pervaporation (12, 15), and membrane evaporation (8, 30) are examples of such processes. Although all of these techniques still suffer from a range of drawbacks, some of the membrane processes (pervaporation and membrane evaporation) appear to be the methods of choice for on-line product removal because of the possibility of in situ use, the relatively low energy requirements, the commercial availability of technology (5), and the lack of toxicity. A combination of pervaporation and distillation appears to have the lowest energy requirements for product separation (9).

The aim of this work is to achieve and maintain the conditions which allow for degeneration-free, long-term stable continuous two-stage cultivation of *Clostridium beijerinckii* NRRL B592 with a high overall solvent productivity. Carrier material was used in both stages to demonstrate the effect of carrier material on the reactor productivity when used in the second stage of a two-stage system. A membrane evaporation module was integrated into the recirculation loop of second-stage bioreactor to counter product inhibition and allow higher productivities and sugar utilization. The decision to use membrane evaporation rather than pervaporation was made because of the higher solvent membrane fluxes allowed by membrane evaporation. The fundamental principles of membrane evap-

oration and pervaporation are identical; the difference lies only in the type of membrane used. Porous membranes allow high membrane fluxes and relatively low selectivities and are used for membrane evaporation; nonporous membranes allow low membrane fluxes, give high selectivities, and are used for pervaporation (2).

MATERIALS AND METHODS

Organism. *C. beijerinckii* NRRL B592 (capable of producing a mixture of neutral solvents consisting of acetone, *n*-butanol, and ethanol) was used. Spores were stored in sterile medium at 4°C. The inoculum was prepared by injecting 35 ml of the spore suspension into 330 ml of the medium, heat shocking at 85°C for 10 min, and immediately cooling in cold water and incubating at 36°C. The first stage (Fig. 1) was then inoculated with 25 ml of cell suspension in a state of high motility (approximately 24 h after heat shocking).

Medium. The same composition was used both for preparation of inoculum and for continuous-cultivation experiments. This semisynthetic mixture contained 60.0 g of glucose (Laevosan, Linz, Austria), per liter, 5.0 g of yeast extract per liter, 1.0 g of $K_2HPO_4 \cdot 3H_2O$ per liter, 1.0 g of KH_2PO_4 per liter, 1.0 g of $MgSO_4 \cdot 7H_2O$ per liter, 0.5 g of $FeSO_4 \cdot 7H_2O$ per liter, 0.1 g of *p*-aminobenzoic acid per liter, 2.3 g of glacial acetic acid per liter (all obtained from Merck, Darmstadt, Germany), 2.0 g of ammonia solution (32% solution; no. 5426; Merck, Darmstadt, Germany) per liter, and distilled water to 1 liter. This composition was suitable for the continuous experiment with a chemostat culture under product limitation.

After preparation, the medium was autoclaved at 10^5 Pa (121°C) for 16 min and cooled. The head space was flushed continuously with oxygen-free nitrogen gas during and after cooling to maintain anaerobic conditions in the medium container.

Bioreactors and growth conditions. A tower bioreactor made of glass, with a jacketed lower part (inner diameter, 40 mm; length, 140 mm) and upper part (inner diameter, 62 mm; height, 60 mm; volume, 250 ml) was used as the first

TABLE 1. Estimation of the active fermentation volumes used during two-stage continuous-cultivation experiments with *C. beijerinckii* NRRL B592 with and without product removal

| Substance | Vol (ml) | | | Overall ^a |
|-------------------------------|-------------|--------------|---------|----------------------|
| | First stage | Second stage | Overall | |
| Fermented medium | 170 | 550 | 720 | 720 |
| Carrier material ^b | 30 | 150 | 180 | 180 |
| Recirculation loop | 50 | 300 | 350 | 350 |
| Membrane module | | | | 100 |
| Total | 250 | 1,000 | 1,250 | 1,350 |

^a Overall volume during the experiment with on-line membrane evaporation (2,166 to 2,465 h after the start of operation).

^b The volume of carrier material presented here is the total volume of the LECA particles themselves excluding voidage between the particles but including the volume of the pores within the particles.

cultivation stage (Fig. 1). The bioreactor contained 30 ml of LECA particles (particle size, 5 to 10 mm), which served as a carrier material. LECA (obtained from Österreichische Leuca GmbH, Fehring, Austria) is a synthetic pumice and is a low-cost, porous ceramic product with limited structural strength. The pores are produced by the liberation of CO during firing of the mixture (1,100 to 1,200°C), and their size is controlled by the firing temperature and mixture composition. LECA contains about 60% SiO₂, about 20% Al₂O₃, about 8% Fe₂O₃, and small amounts of calcium, potassium, sodium, magnesium, sulfur, and phosphorus oxides (11).

The liquid content of the first stage was recirculated through silicone tubing by means of a peristaltic pump (Ismatec, Zurich, Switzerland) at a rate of 12 liters/h. Fresh medium was introduced into the recirculation loop via a peristaltic pump (Watson-Marlow Ltd., Falmouth, England). The overall volume of the first cultivation stage (including medium, carrier material, and the recirculation loop) was 250 ml (Table 1). The dilution rate was maintained at values between 0.5 and 0.6 h⁻¹. Heating water was circulated through the jacketed lower part of the bioreactor to maintain the temperature at 36°C. The pH of the culture was between 4.60 and 4.70 without the use of pH regulation. To achieve anaerobiosis, oxygen-free nitrogen gas was flushed through the head space of the first-stage bioreactor.

The second stage consisted of a tower bioreactor made of glass, with a jacketed lower part (inner diameter, 30 mm; length, 300 mm) and upper part (inner diameter, 100 mm; height, 140 mm), and had a volume of 1 liter. This bioreactor also contained LECA particles (150 ml) and was fed during continuous operation with the effluent from the first stage. To recirculate the medium, silicone tubing and a peristaltic pump (Ismatec) were used. The recirculation rate was 25 liters/h. The overall volume of the second cultivation stage (including medium, carrier material, and the recirculation loop), excluding the membrane module, was 1 liter (Table 1). The dilution rate was maintained at about 0.15 to 0.20 h⁻¹. Heating water was circulated through the bioreactor jacket to maintain the temperature at 36°C. The pH of the culture in the second stage was between 4.70 and 4.75 without external control.

Membrane evaporation. A hollow-fiber membrane evaporation module (Enka, Wuppertal, Germany) was used to remove the solvents generated during continuous cultivation. The module consisted of three membrane fibers made of polypropylene with an inner diameter of 5.5 mm and a pore diameter of 0.2 μm and with housing also made of polypropylene. The membrane area of this module, based on the inner fiber diameter, was 0.036 m². The calculated module volume was approximately 50 ml. Its integration in the recirculation loop of the second-stage bioreactor caused an 8% increase in the overall medium volume and a corresponding decrease in the overall dilution rate (Table 1). Before the membrane module was installed into the recirculation loop of the second-stage bioreactor, the hollow fibers were disinfected inside with 30% ethanol for 24 h and then flushed with sterile distilled water before use.

A vacuum was used instead of sweep gas on the permeate side of the membrane module (8) to achieve the higher membrane fluxes and to increase the membrane selectivity. The permeate side of the module was connected to a vacuum pump (ABM, Marktredwitz, Germany) to generate the vacuum. The pressure was approximately 3 kPa on the permeate side of module and in the condensation system.

A glass condenser equipped with a cooling jacket and a cooling coil (60 cm long) was used to condense the vapors permeated. The condensed mixture was collected in a jacketed glass condensate tank. Both the condenser and the condensate tank were cooled with 50% ethylene glycol in water. The coolant was cooled and recycled by a cooler (Lauda, Königshofen, Germany). The temperature measured in the condensate tank was about 5°C.

Analyses. The concentrations of solvents and acids were determined with a gas chromatograph (model GC-9A; Shimadzu Corp., Kyoto, Japan) equipped with a

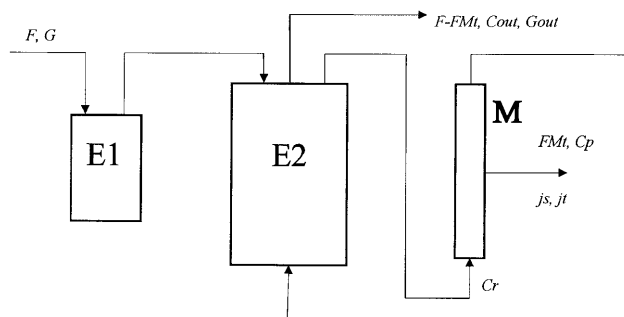

FIG. 2. Material balance of a two-stage continuous ABE fermentation with on-line product removal. Fresh medium containing glucose at a concentration G is added to the first-stage bioreactor (E1) at a flow rate F . The outflow from the first stage enters the second stage (E2) at the same flow rate, F . The content of the second-stage bioreactor, containing solvents at a concentration C_r , is recirculated through the membrane evaporation module (M). The solvents are removed from the fermentation mixture in the module. The permeate concentration is C_p , and the membrane flux is characterized by F_{Mt} , j_s , and j_i . After passing the membrane module, the fermentation mixture (poor in solvents) is introduced back into the second-stage bioreactor. The outflow from the second stage ($F - F_{Mt}$) contains solvents at a concentration C_{out} and glucose at a concentration G_{out} .

flame ionization detector and a glass column (3.2 mm by 2.6 m) packed with Chromosorb 101 (Supelco, Inc., Bellefonte, Pa.) at a column temperature of 170°C. Nitrogen gas (80 ml/min) was used as the carrier gas. For sample preparation, *i*-butanol solution was used as an internal standard and *o*-phosphoric acid solution was used as an acidification agent.

Glucose was determined by high-performance liquid chromatography (Bio-Rad Laboratories, Richmond, Calif.), equipped with an Inores S 259-H column (Inovex, Vienna, Austria) packed with Inores cation exchanger (particle size, 9 μm). The column was heated at 70 ± 1°C, and the eluent (0.01 M H₂SO₄) was circulated with a flow rate of 0.60 ml/min. A cellobiose (Roth, Karlsruhe, Germany) solution was added to the samples as an internal standard. For peak detection, a refractive index monitor (model 1755; Bio-Rad) was used.

Calibration and analyses were performed by a two-point internal standard procedure.

Calculation of bioprocess parameters. As shown on the flow sheet of the material balance (Fig. 2), the overall solvent productivity during continuous cultivation of solvent-producing clostridia with on-line product removal by membrane evaporation can be expressed as follows:

$$P = [C_p \times F_{Mt} + C_{out} \times (F - F_{Mt})] / \rho \times V_t \quad (1)$$

where $F_{Mt} = 0$ in the absence of on-line product removal. The substrate utilization rate during continuous experiment with on-line product removal can be expressed as follows:

$$S = [G \times F - G_{out} \times (F - F_{Mt})] / \rho \times V_t \quad (2)$$

The solvent yield is the ratio of equations 1 and 2:

$$Y_{pls} = P/S$$

The substrate (glucose) utilization during on-line product removal can be expressed as

$$U = [1 - G_{out} \times (F - F_{Mt}) / (G \times F)] \times 100$$

The specific membrane flux can be estimated as follows:

$$j_i = F_{Mt}/A$$

and the specific solvent flux through the membrane can be estimated as follows:

$$j_s = (F_{Mt} \times C_p) / (\rho \times A)$$

The overall membrane selectivity is expressed as

$$\alpha = C_p \times (1 - C_r/\rho) / [C_r \times (1 - C_p/\rho)]$$

The total dilution rate was calculated from the total-volume values (Table 1), i.e., the full working volume of the reactors:

$$D = F / (\rho \times V_t)$$

In the above equations, A is the membrane area (square meters), C_{out} is the concentration of solvents in the outflow from the second cultivation stage (grams

TABLE 2. Fermentation profiles of *C. beijerinckii* NRRL B592 when grown in a two-stage continuous culture with and without product removal

| Parameter | Value of parameter ^d | | | | | | |
|---|---|---------------------------|-----------------|--------------------------------------|---------------------------|----------------------|------------------------|
| | Without product removal (1,465–2,166 h) | | | With product removal (2,166–2,263 h) | | | |
| | First stage | Second stage ^b | Overall | First stage | Second stage ^c | Overall ^d | Highest value measured |
| Temp (°C) | 35.88 | 35.83 | | 36.43 | 32.09 | | |
| pH | 4.70 | 4.71 | | 4.63 | 4.74 | | |
| Redox potential (mV) | -410 | -446 | | -399 | -435 | | |
| Total solvents (g/liter) | 2.52 | 6.76 | 9.27 | 3.28 | 4.95 | 13.09 | |
| <i>n</i> -Butanol (g/liter) | 1.45 | 4.12 | 5.57 | 1.96 | 3.21 | 7.79 | |
| Acetone (g/liter) | 0.88 | 2.09 | 2.98 | 1.10 | 1.29 | 4.18 | |
| Ethanol (g/liter) | 0.18 | 0.54 | 0.73 | 0.22 | 0.45 | 1.12 | |
| A/B/E ratio ^e (%) | 35:58:7 | 31:61:8 | 32:60:8 | 33:60:7 | 26:65:9 | 32:60:8 | |
| Acetic acid ^f (g/liter) | 2.22 | -0.32 | 1.90 | 2.60 | 2.61 | 1.71 | |
| Butyric acid (g/liter) | 1.43 | -0.27 | 1.16 | 1.43 | 1.15 | 0.71 | |
| Dilution rate (h ⁻¹) | 0.57 | 0.18 | 0.13 | 0.55 | 0.15 | 0.12 | |
| Solvent productivity ^g (g/liter/h) | 1.39 | 1.20 | 1.24 | 1.77 | 1.70 | 1.72 | 1.95 |
| Solvent productivity ^h (g/liter/h) | 11.82 | 6.17 | 7.11 | 15.01 | 10.06 | 10.89 | 12.46 |
| Glucose utilized (%) | 35 | 49 | 68 ⁱ | 30 | 73 | 87 | 96 |
| Solvent yield ^j (g/g) | 0.12 | 0.26 | 0.23 | 0.18 | 0.32 | 0.28 | 0.31 |
| Product yield ^k (g/g) | 0.29 | 0.32 | 0.30 | 0.41 | 0.27 | 0.30 | |

^a The mean values of the calculated process parameters are presented. They are calculated as the sum of all measured values divided by the number of measurements (i.e., the statistical mean value).

^b The concentration-dependent parameters of the second stage were calculated as a difference between overall values (i.e., values of the second-stage effluent) and first-stage values.

^c The concentrations are actually the retentate parameters, i.e., values measured in the outflow from the second stage; however, solvent productivities, glucose utilized, and yields were calculated as a difference between overall values (i.e., effective values) and first-stage values.

^d Effective values, adjusted numerically to reflect products removed by membrane evaporation (2,166 to 2,263 h of experiment duration).

^e A/B/E ratio, ratio of values for acetone, *n*-butanol, and ethanol.

^f Acetate is present in the feed.

^g Solvent productivity calculated from the total bioreactor volume.

^h Solvent productivity calculated from the carrier material volume.

ⁱ The fermentation was limited by product inhibition.

^j Solvent yield was calculated from the glucose content in the feed; other C sources were ignored.

^k Solvents plus acids (i.e., all products except gaseous products).

per liter), C_p is the concentration of solvents in the permeate (grams per liter), C_r is the concentration of solvents in the retentate (i.e., the second cultivation stage) (grams per liter), D is the overall dilution rate (reciprocal hours), F is the feed in-flow (grams per hour), F_{Mf} is the total flux through the membrane (grams per hour), G is the concentration of glucose in the feed (grams per liter), G_{out} is the concentration of glucose in the outflow from the second cultivation stage (grams per liter), j_s is the specific flux of solvents through the membrane (grams per square meter per hour), j_i is the specific overall flux through the membrane (grams per square meter per hour), P is the solvent productivity (grams per liter per hour), RT is the retention time ($= \rho \times V_t / F$) (hours), S is the substrate (glucose) utilization rate (grams per liter per hour), U is the substrate (glucose) utilized (percent), V_t is the total volume (liters), $Y_{p/s}$ is the yield of solvents (grams per gram), α is the membrane selectivity, and ρ is the density (grams per liter) (a density of 1,000 g/liter was assumed).

RESULTS

Long-term stable cultivation. The culture in the first stage was held in the steady state for 500 h (from h 1465 to 1987), i.e., 300 retention times (RT) to demonstrate a stable solvent-producing continuous culture. Mean values for each parameter were calculated over the entire period under consideration and are presented in Table 2. Solvent production occurred mostly in the second stage because of the lower dilution rate, and the product concentrations in this stage reached inhibitory levels (20).

The curves of total solvent and glucose concentrations (Fig. 3), total solvent productivity (Fig. 4), yield of solvents (Fig. 5), and glucose utilization (Fig. 6) plotted against time show periodic oscillations with a period of approximately 70 h. Such oscillations are characteristic of continuously solvent-producing clostridial culture (3) and appear to be associated with high glucose concentrations in the feed (26).

About one-third of the glucose in the feed was assimilated in the first stage, and about one-half was assimilated in the second stage, resulting in an overall glucose utilization of about two-thirds (Table 2).

After about 300 RT (1,987 h) the dilution rate was doubled, causing an abrupt change in all concentrations (Fig. 3 to 5). Within 15 RT (100 h), however, the solvent productivity had returned to its previous level (Fig. 4). Because of a decrease in both solvent concentration and solvent yield and an increase in the outflow glucose concentration after 15 RT, the dilution rate was reset to its previous level (Fig. 3). The doubling of the dilution rate described above caused no detrimental effects to the bacterial cells.

Experiments with on-line membrane evaporation. At h 2166 and after 700 h (ca. 90 overall RT) of steady-state operation, solvent recovery was incorporated into the recirculation loop of the second stage (Fig. 3 to 6). The startup of on-line membrane evaporation caused a drop in temperature in the second stage (Table 2) as a result of evaporation and also caused a decrease in the concentrations of solvents in the second stage (Fig. 3). The concentration of solvents was reduced significantly (from 9.27 to 4.56 g/liter for total solvents, from 5.57 to 3.07 g/liter for *n*-butanol), allowing better glucose utilization and a 40% increase in solvent productivity (Fig. 4 to 6). During the following 95 h (i.e., ca. 12 overall RT), the overall solvent productivity reached a peak value of 1.95 g/liter/h, the overall yield of solvents peaked at 31%, and the glucose utilization reached 96% (Table 2). The permeate flux through the membrane after startup was about 1,500 g/m²/h (Fig. 7) and

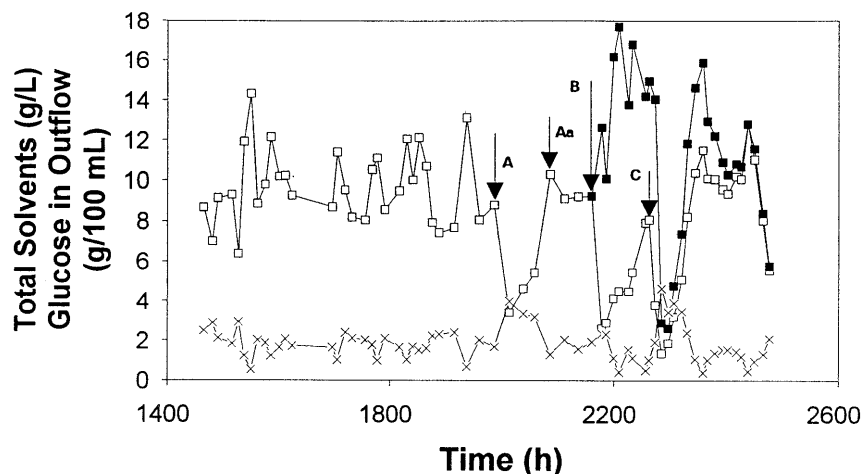

FIG. 3. Time course of the two-stage continuous acetone-butanol-ethanol fermentation by *C. beijerinckii* NRRL B592. Between 1,465 and 1,987 h after the start of operation, the overall dilution rate was kept at an average level of 0.13 h^{-1} . At point A (1,987 h) the overall dilution rate was doubled, causing a decrease in outflow solvent concentration (\square) and an increase in outflow glucose concentration (\times). At point B (2,166 h), the product removal was started, causing a decrease in outflow solvent and glucose concentrations. The effective total solvent concentration, adjusted numerically to reflect products removed by membrane evaporation (\blacksquare), showed increased values compared with the outflow solvent concentrations achieved without on-line product removal (1,465 to 2,166 h of operation). At point C (2,263 h), batch fermentation operation with on-line product removal was started, causing a decrease both in outflow solvent concentration and in effective solvent concentration, as well as an increase in outflow glucose concentration.

amounted to about 30% of the feed (F). Since sugars do not permeate through the membrane used, concentration buildup in the medium in the second stage as a result of water flux through the membrane occurred. No detrimental effects on the culture were observed. After 89 h (i.e., 11 RT) of membrane evaporation, the concentration of solvents in stage 2 again reached inhibitory levels (7.90 g/liter for total solvents, 5.04 g/liter for *n*-butanol) and the capacity of the membrane module used was not sufficient to allow further improvement of glucose utilization and solvent productivity.

To investigate the influence on the cells of a buildup of the medium concentration the system was switched to batch operation after 2,263 h of operation (Fig. 3 to 6). The fluid volume in stage 2 dropped steadily as a result of continued membrane evaporation, thereby causing an increase in osmotic pressure.

The result was a drastic decrease in solvent productivity and glucose utilization (Fig. 4 and 6), associated with a decrease in solvent concentration both in the medium and in the permeate. Continuous operation was started again after 2,273 h. After about 7 overall RT (2,331 h of operation), the concentration of solvents in medium once again reached inhibitory levels (8.20 g/liter for total solvents, 5.05 g/liter for *n*-butanol) and remained at this level for next 16 overall RT. During this period, both the solvent productivity and glucose utilization were limited by the performance of the membrane evaporation, which decreased steadily after recovery from batch operation (after 2,345 h of operation), i.e., after 179 h of on-line product removal (Fig. 4 and 6). The decrease of permeate flux was accompanied by a decrease of both solvent flux through the membrane and membrane selectivity.

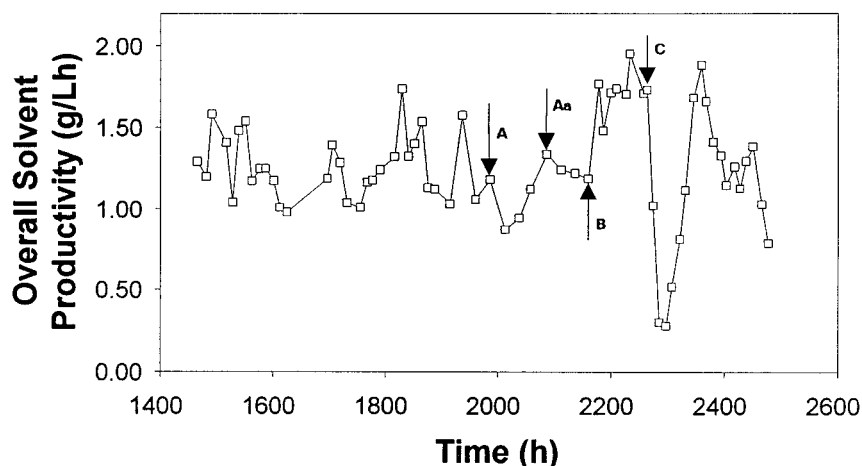

FIG. 4. Time profile of the overall solvent productivity obtained during continuous two-stage cultivation of *C. beijerinckii* NRRL B592. Between 1,465 and 1,987 h after the start of operation, the overall dilution rate was kept at an average level of 0.13 h^{-1} . At point A (1,987 h), the overall dilution rate was doubled, causing an initial decrease in overall solvent productivity followed by an increase during the next 100 h and reaching the previous levels at point Aa (2,087 h), where the dilution rate was set to the previous level. At point B (2,166 h), the product removal was started, causing an increase in overall solvent productivity by approximately 38%. At point C (2,263 h), batch fermentation operation with on-line product removal was started, causing an abrupt decrease in solvent productivity.

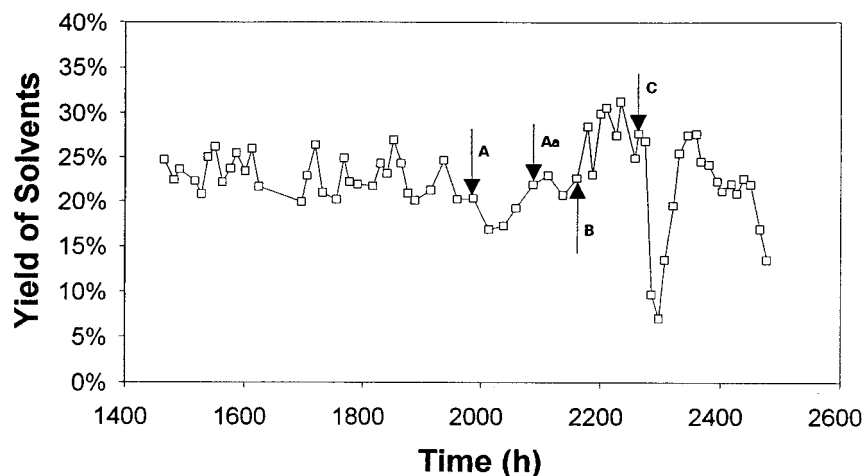

FIG. 5. Time profile of the solvent yield obtained during continuous two-stage cultivation of *C. beijerinckii* NRRL B592. At point A (1,987 h of operation), the overall dilution rate was doubled, causing a decrease in solvent yield. After the dilution rate was set to the previous level at 2,087 h (point Aa) the solvent yield reached previous levels. At point B (2,166 h) the product removal was started, causing an increase in solvent yield of approximately 22%. At point C (2,263 h), batch operation with on-line product removal was started, causing an abrupt decrease in solvent yield in the fermentation.

The steady decrease in solvent productivity after recovery from batch operation (after 2,345 h of operation) was the first sign of culture degeneration, which resulted in a sudden decrease in solvent concentration approximately 200 h later (after 2,465 h of operation). The phenomenon of degeneration is well documented (7, 11, 20, 23, 37) and will not be further discussed in this paper.

Butyric acid. Butyric acid levels were generally lower in the second stage than in the first stage (Fig. 8), presumably because of reassimilation for solvent production. However, three peaks of butyric acid concentration in the second stage can be observed: (i) the first peak after 2,013 h of operation caused by doubling of dilution rate, which seemed to reinduce exponential growth in the second stage; (ii) a second peak (negative) after the startup of on-line membrane evaporation as a result of more intensive reassimilation of butyric acid; and (iii) a third peak during batch operation with on-line membrane evaporation, probably as a result of metabolic stress caused by con-

centration of the medium and associated increased osmotic pressure, accompanied by loss of the acid reassimilation ability.

After the startup of on-line membrane evaporation and a short period of adaptation, the concentration of butyric acid remained very low (Table 2). This fact confirmed an improved reassimilation of butyric acid during on-line product removal, along with more complete glucose utilization, higher solvent productivity, and higher solvent yield (Table 2). The large peak during batch operation at h 2263 disappeared after a return to continuous operation.

DISCUSSION

The use of two-stage continuous solvent-producing cultures has been proposed as a method of choice during cultivation of free-suspended cells in stirred tank bioreactors (14, 25). Continuous cultivation with increased cell concentrations (e.g., cross-flow microfiltration, immobilization techniques, and use

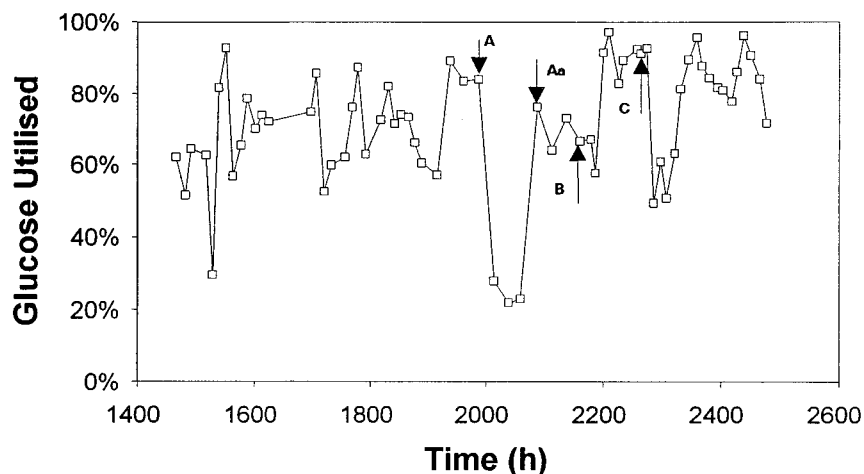

FIG. 6. Time profile of the glucose utilization during continuous two-stage cultivation of *C. beijerinckii* NRRL B592. At point A (1,987 h), the overall dilution rate was doubled, causing decreased glucose utilization. After the dilution rate was set to the previous level at 2,087 h of operation (point Aa), the glucose utilization returned to previous levels. At point B (2,166 h), the product removal was started, causing an increase in glucose utilization by approximately 28%. At point C (2,263 h), batch operation with on-line product removal was started, causing a decrease in glucose utilization in the fermentation.

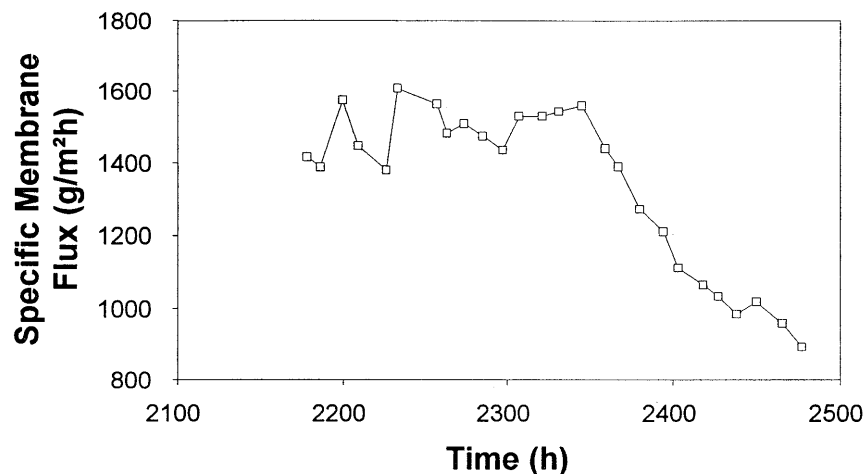

FIG. 7. Time profile of the specific membrane flux achieved by the polypropylene membrane when coupled to the second stage of a two-stage continuous fermentation by *C. beijerinckii* NRRL B592. The specific membrane flux for the first 179 h was in the range of approximately 1,400 to 1,600 g/m²/h. After 179 h (2,345 h of fermentation time), the overall membrane flux started to decrease.

of carrier material) has, however, been based almost exclusively on single-stage cultivation equipment. Friedl et al. (8) used a fluidized bed bioreactor with an associated buffer tank for the membrane module during continuous cultivation with on-line product removal. Since substrate utilization could be observed in the buffer tank, it must be assumed that cell metabolism continued in the buffer tank, and therefore the buffer tank must be considered to be a second cultivation stage. Since the recirculation rate from this second bioreactor was much higher (about 340 times) than the feed rate, the two bioreactors were not connected in series but functioned as two coupled bioreactors.

Our experiments are based on the use of a two-stage continuous fermentation, whereby the first stage allows the production of viable cells and solvent production occurs mainly in the second stage. During previous experiments, carrier material was used only in the first stage and the second stage operated as a continuous stirred tank reactor with freely sus-

ended cells and without carrier material. Under these conditions, a relatively high sugar concentration (about 30 g/liter) and low solvent concentration (about 7 g/liter for total solvents) at an overall dilution rate of approximately 0.12 h⁻¹ were measured in the second stage (implying overall solvent productivities in the region of 0.8 g/liter/h) (our unpublished results, partially presented in Table 3). When using carrier material in the second stage as well, as described in this work, it was possible to significantly increase the final solvent concentration and solvent productivity in the second stage. The productivity values in the first and second stages (Table 2) showed values similar to each other. The mean values of solvent productivity in both stages (Table 2) were not statistically different, thus justifying the use of carrier material in both stages.

In contrast to the work of Maddox, in which the butanol-producing bacteria grow profusely on the carrier material bone char (25), the LECA particles used did not become coated with

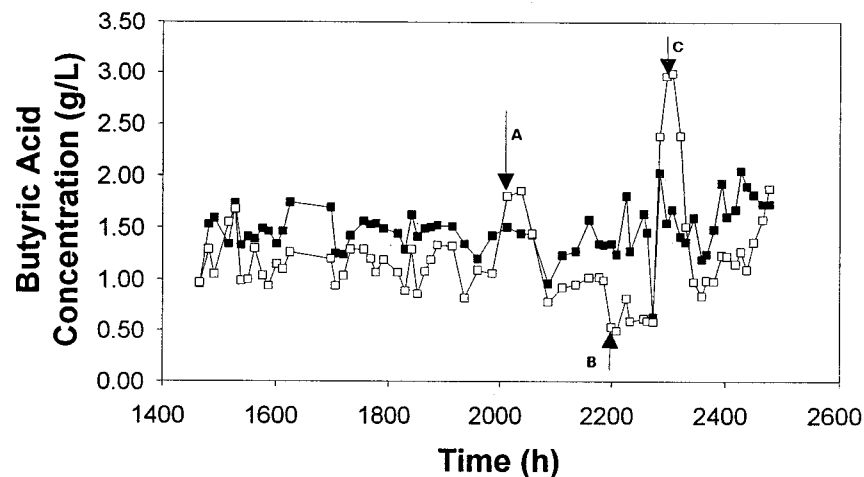

FIG. 8. Time profiles of the butyric acid concentrations in the first (■) and second (□) stages during continuous two-stage fermentation by *C. beijerinckii* NRRL B592. Between 1,465 and 1,987 h after the start of operation, the butyric acid concentration in the second stage was lower than in the first stage. At point A (1,987 h), the overall dilution rate was doubled, causing an increased butyric acid concentration in the second stage. The startup of on-line product removal at 2,166 h (point B) caused a further reduction in effective butyric acid concentration. At point C (2,263 h), batch fermentation operation was started, causing an increase in the effective butyric acid concentration.

TABLE 3. Solvent productivity achieved by *C. beijerinckii* NRRL B592 in the second stage of the two-stage continuous-cultivation experiments^a

| Run | Carrier material ^b | Dilution rate (h ⁻¹) | Solvent productivity (g/liter/h) |
|-------------------------|-------------------------------|----------------------------------|----------------------------------|
| Control ^c | Not present | 0.16 | 0.37 |
| Experiment ^d | Present | 0.18 | 1.20 |

^a The experimental setup was almost identical, except that a carrier material was used in stage 2 in the experiment described in this paper.

^b Carrier material in second stage.

^c Unpublished results.

^d Values for the experimental period without product removal (1,465 to 2,166 h). See Table 2.

a visible bacterial mass but retained their red-brown appearance. The determination of concentration of active cell mass in these experiments is very difficult, not just because of the (probably) very low proportion of active cells present (25) but also because of the distribution of active cells in different areas of the system, i.e., (i) in the pores of the carrier material; (ii) present as a film on the carrier material, on the fermentor walls, and inside the tubings used; (iii) present as flocs in the medium; and (iv) in the foam on the liquid surface.

Although cell concentrations are necessary to understand the detailed functions of the system, such data are not presented here because they are not required to demonstrate the productivities achieved with the carrier material and reactor configuration used.

Microorganisms do grow inside porous structures in spite of significant production of gases, as shown, for example, by the scanning electron microscope investigation of *Zymomonas mobilis* cultures on sinterglass (36). For this reason, the volume of the carrier was included in the total reaction volume (V_r) because of the high porosity of the particles.

The relatively low yield of solvents (Table 2) might be related to the high concentration of Fe²⁺ ions in the medium (21); however, a high concentration of Fe²⁺ might also provide protection against phage invasion (27), hence contributing to the long-term stability of continuous culture.

The productivity values, with the exception of the following calculation based on bed volume, as well as all other volume-dependent cultivation parameters, have been calculated from the total reaction volume (Table 1). Another approach, sometimes applied to packed-bed bioreactors (8, 25), is to calculate the productivity merely on the basis of the volume of packed beds (i.e., carrier material). A number of the characteristic parameters of the system have been recalculated on this basis and are presented in this paragraph to allow the reader to compare the performance of the fermentation presented in this publication with other literature. Calculated in this manner, the mean productivities in Table 2 would be 11.82 g/liter/h in the first stage, 6.17 g/liter/h in the second stage, and 7.11 g/liter/h overall, or 15.01 g/liter/h in the first stage, 10.06 g/liter/h in the second stage, and 10.89 g/liter/h overall during on-line membrane evaporation.

Although long-term stable solvent production during continuous cultivation of *C. beijerinckii* strains was said to be transient (17, 18, 20), under the conditions used in this experiment (i.e., a two-stage product-limited continuous culture with use of carrier material, a relatively high dilution rate in the first stage, and no nutrient limitation or pH control), the culture of *C. beijerinckii* NRRL B592 used did maintain production of neutral solvents for over 91 overall RT. This corresponded to 400 RT in the first cultivation stage, which supplies the system

TABLE 4. Parameters of the permeate obtained during continuous cultivation of solvent-producing clostridia coupled to the different on-line product removal membrane techniques

| Parameter | Value for: | | |
|-------------------------------------|--------------------|------------------------|----------------------|
| | Pervaporation | Membrane evaporation | Membrane evaporation |
| Membrane type | Silicone tubes | Porous PP ^a | Porous PP |
| Mode of operation | Sweep gas | Sweep gas | Vacuum |
| <i>n</i> -Butanol (g/liter) | 42–126 | 7.9 ^b | 16.71 ^c |
| Acetone (g/liter) | | NR | 11.00 ^c |
| <i>i</i> -Propanol (g/liter) | 14–34 | | |
| Ethanol (g/liter) | | NR | 1.44 ^c |
| Total solvents (g/liter) | | 11.9 ^b | 29.15 ^c |
| Membrane flux (g/m ² /h) | 19.4 | NR | 1,482 ^c |
| Solvent flux (g/m ² /h) | NR | 7.1 ^b | 43.16 ^c |
| Selectivity | 11–31 ^d | 5 ^b | 6.3 ^c |
| Reference | 15 | 8 | This work |

^a PP, polypropylene.

^b The top values reported.

^c Mean values.

^d Membrane selectivity related only to *n*-butanol.

with fresh cells. This leads to the conclusion that *C. beijerinckii* NRRL B592 is indeed capable of maintaining normal cell metabolism and supporting solvent production for prolonged periods.

The integration of a membrane evaporation module in the recirculation loop of the second cultivation stage showed a positive influence on solvent productivity, solvent yield, and glucose utilization (Table 2). Additionally, it seems that the on-line membrane evaporation can reduce the magnitude of metabolic oscillations, allow the use of higher sugar concentrations in the feed, and therefore reduce the costs of processing in the industrial plant.

It seems likely that the switch to batch cultivation after 2,263 h of operation caused the loss of solvent-producing ability and led to degeneration of the culture. This seems to indicate that the changes of culture conditions which occurred (accumulation of mineral salts and increase of osmotic pressure) are factors which can induce culture degeneration. Similar results were obtained during batch cultivation of *C. acetobutylicum* P262 with on-line membrane evaporation, in which the culture degeneration occurred after 13 days of operation (25). Moderate concentrating of medium, however, as achieved in this work during continuous operation (about 30%), did not appear to adversely affect the culture.

The flux of solvents through the membrane during on-line membrane evaporation reached approximately 40 g/m²/h (Table 4), and membrane selectivity was about 6. Compared with the use of sweep gas on the permeate side of the identical membrane (8), the use of vacuum in this experiment resulted in 5- to 10-fold-higher solvent membrane flux whereas the solvent selectivity was not significantly different (Table 4). Hence, the use of vacuum instead of sweep gas on the permeate side of the membrane allows a smaller membrane area with the same effect. The use of pervaporation, as opposed to membrane evaporation (12, 15), results in higher solvent concentrations in the permeate and higher membrane selectivities, but the membrane fluxes would be lower (Table 4). Higher membrane fluxes with corresponding smaller membrane areas are an important factor when considering commercial production.

It was shown by using synthetic alcohol-water mixtures that the flux of alcohols through the membrane increases as the concentration of alcohols in water increases (15). The polypro-

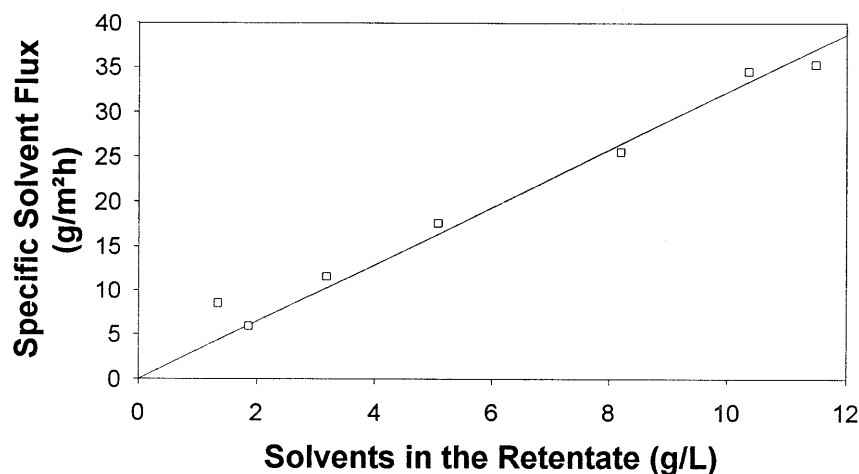

FIG. 9. Specific solvent flux through the membrane plotted against the concentration of solvents in the retentate (i.e., the second fermentation stage). The experimental datum points (\square) were obtained during continuous two-stage cultivation of *C. beijerinckii* NRRL B592 with on-line membrane evaporation (between 2,166 and 2,263 h of fermentation time). The regression showed a very high linear dependence ($r^2 = 0.9706$) of the two variables.

ylene membrane used during the part of experiment with on-line product removal (after 2,166 to 2,263 h of operation) showed similar behavior (Fig. 9), thus confirming this effect in complex fermented medium.

The overall concentrations of solvents in the permeate reached about 30 g/liter, which is about 3 times higher than achieved with a sweep gas (Table 4). Acids were not present in the permeate initially (after 2,166 to 2,263 h of operation) but started to appear after batch operation and the associated higher acid concentrations after 2,263 h. Their concentration in the permeate was relatively low (0.5 to 1.5 g/liter) and was directly related to the medium concentration.

The feasibility of achieving and maintaining long-term stable continuous cultures with *C. beijerinckii* NRRL B592 at high solvent concentrations and solvent productivities has been presented in this work. The use of an integrated membrane evaporation improved solvent productivity, solvent yield, and substrate utilization. The membrane would also significantly reduce the costs of distillation in a commercial plant and even appears to reduce the metabolic oscillations observed in continuous culture and enable more stable operation. Subsequent optimization of the continuous cultivation of *C. beijerinckii* with integrated on-line membrane evaporation would further improve performance.

ACKNOWLEDGMENTS

We are grateful to Michael Harasek for his help and assistance concerning membrane evaporation.

REFERENCES

1. Beeffink, H. H., M. van Dillen, and J. C. van den Heuvel. 1988. Formation of bacterial aggregates in a continuous-flow reactor: influence of carrier availability. *Biotechnol. Lett.* **10**:171-176.
2. B ddeker, K. W. 1990. Terminology in pervaporation. *J. Membr. Sci.* **51**: 259-272.
3. Clarke, K. G., G. S. Hansford, and D. T. Jones. 1988. Nature and significance of oscillatory behaviour during solvent production by *Clostridium acetobutylicum* in continuous culture. *Biotechnol. Bioeng.* **32**:538-544.
4. Eckert, G., and K. Sch gerl. 1987. Continuous acetone-butanol production with direct product removal. *Appl. Microbiol. Biotechnol.* **27**:221-228.
5. Ennis, B. M., N. A. Gutierrez, and I. S. Maddox. 1986. The acetone-butanol-ethanol fermentation—a current assessment. *Process Biochem.* **21**:131-147.
6. Ennis, B. M., and I. S. Maddox. 1989. Production of solvents (ABE fermentation) from whey permeate by continuous fermentation in a membrane bioreactor. *Bioprocess Eng.* **4**:27-34.
7. Finn, R. K., and J. E. Nowrey. 1958. A note on the stability of clostridia when held in continuous culture. *Appl. Microbiol.* **7**:29-32.
8. Friedl, A., N. Qureshi, and I. S. Maddox. 1991. Continuous acetone-butanol-ethanol (ABE) fermentation using immobilized cells of *Clostridium acetobutylicum* in a packed bed reactor and integration with product removal by pervaporation. *Biotechnol. Bioeng.* **38**:518-527.
9. Friedl, A., and A. Schmidt. 1992. Produktabtrennung bei Alkohol-Fermentationen. *Chem. Ing. Tech.* **64**:871-872.
10. Gapes, J. R. 1993. The acetone-butanol-ethanol fermentation. Ph.D. thesis. Technical University, Vienna, Austria.
11. Gapes, J. R., V. F. Larsen, and I. S. Maddox. 1983. A note on procedures for inoculum development for the production of solvents by a strain of *Clostridium butylicum*. *J. Appl. Bacteriol.* **55**:363-365.
12. Geng, Q., and C. H. Park. 1994. Pervaporative butanol fermentation by *Clostridium acetobutylicum* B18. *Biotechnol. Bioeng.* **43**:978-986.
13. George, H. A., J. L. Johnson, W. E. C. Moore, L. V. Holdeman, and J. S. Chen. 1983. Acetone, isopropanol, and butanol production by *Clostridium beijerinckii* (syn. *Clostridium butylicum*) and *Clostridium aurantibutyricum*. *Appl. Environ. Microbiol.* **45**:1160-1163.
14. Godin, C., and J. M. Engasser. 1989. Acid in the first stage is a determinant factor for the solvent production in the two-stage continuous fermentation of *Clostridium acetobutylicum*. *Biotechnol. Lett.* **11**:903-906.
15. Groot, W. J., M. C. H. den Reyer, T. Bart de la Faille, R. G. J. M. van der Lans, and K. C. A. M. Luyben. 1991. Integration of pervaporation and continuous butanol fermentation with immobilized cells. I. Experimental results. *Chem. Eng. J.* **46**:B1-B10.
16. Hartmanis, M. G. N., H.  hlman, and S. Gatenbeck. 1986. Stability of solvent formation in *Clostridium acetobutylicum* during repeated subculturing. *Appl. Microbiol. Biotechnol.* **23**:369-371.
17. J b ses, I. M. L., and J. A. Roels. 1983. Experience with solvent production by *Clostridium beijerinckii* in continuous culture. *Biotechnol. Bioeng.* **25**: 1187-1194.
18. Johnson, J. L., and J. S. Chen. 1995. Taxonomic relationships among strains of *Clostridium acetobutylicum* and other phenotypically similar organisms. *FEMS Microbiol. Rev.* **17**:233-240.
19. Jones, D. T., and S. Keis. 1995. Origins and relationships of industrial solvent-producing clostridial strains. *FEMS Microbiol. Rev.* **17**:223-232.
20. Jones, D. T., and D. R. Woods. 1986. Acetone-butanol fermentation revisited. *Microbiol. Rev.* **50**:484-524.
21. Junelles, A. M., R. Janati-Idrissi, H. Petitdemange, and R. Gay. 1988. Iron effect on acetone-butanol fermentation. *Curr. Microbiol.* **17**:299-303.
22. Kashket, E. R., and Z. Y. Cao. 1993. Isolation of a degeneration-resistant mutant of *Clostridium acetobutylicum* NCIMB 8052. *Appl. Environ. Microbiol.* **59**:4198-4202.
23. Kuzenok, A., and M. Aschner. 1952. Degenerative processes in a strain of *Clostridium butylicum*. *J. Bacteriol.* **64**:829-836.
24. Maddox, I. S. 1989. The acetone-butanol-ethanol fermentation: recent progress in technology. *Biotechnol. Genet. Eng. Rev.* **7**:189-220.
25. Maddox, I. S., N. Qureshi, and N. A. Gutierrez. 1993. Utilization of whey by clostridia and process technology, p. 343-369. In D. R. Woods (ed.), *The clostridia and biotechnology*. Butterworth-Heinemann, Boston.
26. Mulchaldani, A., and B. Volesky. 1994. Production of acetone-butanol-ethanol by *Clostridium acetobutylicum* using a spin filter perfusion bioreactor. *J. Biotechnol.* **34**:51-60.

27. **Ogata, S., and M. Hongo.** 1979. Bacteriophages of the genus *Clostridium*. *Adv. Appl. Microbiol.* **25**:241–273.
28. **Qureshi, N., and I. S. Maddox.** 1987. Continuous solvent production from whey permeate using cells of *Clostridium acetobutylicum* immobilized by adsorption onto bonechar. *Enzyme Microb. Technol.* **9**:668–671.
29. **Qureshi, N., and I. S. Maddox.** 1991. Integration of continuous production and recovery of solvents from whey permeate: use of immobilized cells of *Clostridium acetobutylicum* in a fluidized bed reactor coupled with gas stripping. *Bioprocess. Eng.* **6**:63–69.
30. **Qureshi, N., I. S. Maddox, and A. Friedl.** 1992. Application of continuous substrate feeding to the ABE fermentation: relief of product inhibition using extraction, perstraction, stripping, and pervaporation. *Biotechnol. Prog.* **8**:382–390.
31. **Roffler, S. R., H. W. Blanch, and C. R. Wilke.** 1988. In situ extractive fermentation of acetone and butanol. *Biotechnol. Bioeng.* **31**:135–143.
32. **Rogers, P.** 1986. Genetics and biochemistry of *Clostridium* relevant to development of fermentation processes. *Adv. Appl. Microbiol.* **31**:1–60.
33. **Schoutens, G. H., M. C. H. Nieuwenhuizen, and N. W. F. Kossen.** 1985. Continuous butanol production from whey permeate with immobilized *Clostridium beijerinckii* LMD 27.6. *Appl. Microbiol. Biotechnol.* **21**:282–286.
34. **Shukla, R., W. Kang, and K. K. Sirkar.** 1989. Acetone-butanol-ethanol (ABE) production in a novel hollow fiber fermenter-extractor. *Biotechnol. Bioeng.* **34**:1158–1166.
35. **Welsh, F. W., R. E. Williams, and I. A. Veliky.** 1987. Solid carriers for a *Clostridium acetobutylicum* that produces acetone and butanol. *Enzyme Microb. Technol.* **9**:500–502.
36. **Weuster, D., A. Aivasidis, and C. Wandrey.** 1988. Ethanolfermentation mit *Zymomonas mobilis* im Wirbelschichtreaktor. Reprint from *BioEngineering* 3/88, spec. ed. no. 60006d, Schott, Germany.
37. **Woolley, R. C., and J. G. Morris.** 1990. Stability of solvent production by *Clostridium acetobutylicum* in continuous culture: strain differences. *J. Appl. Bacteriol.* **69**:718–728.
38. **Yan, R. T., C. X. Zhu, C. Golemboski, and J. S. Chen.** 1988. Expression of solvent-forming enzymes and onset of solvent production in batch cultures of *Clostridium beijerinckii* (“*Clostridium butylicum*”). *Appl. Environ. Microbiol.* **54**:642–648.
39. **Zoutberg, G. R., R. Willemsberg, G. Smit, M. J. Teixeira de Mattos, and O. M. Neijssel.** 1989. Solvent production by an aggregate-forming variant of *Clostridium butyricum*. *Appl. Microbiol. Biotechnol.* **32**:22–26.