

## RESTING AND ACTION POTENTIALS IN SINGLE NERVE FIBRES

BY A. L. HODGKIN AND A. F. HUXLEY

*From the Physiological Laboratory, Cambridge, and the Laboratory  
of the Marine Biological Association, Plymouth*

*(Received 20 February 1945)*

Until recently the action potential of nerve and muscle has been thought to arise from a transient breakdown of the polarized cell membrane. This hypothesis was widely accepted as an integral part of the membrane theory of nervous activity, although it rested upon little more than a rough equality in the apparent magnitudes of action and resting potentials. Early in 1939 we made an attempt to check the hypothesis by comparing the relative magnitudes of action and resting potentials in a single nerve fibre. We expected to find that the resting potential would be slightly larger than the action potential, since it was known that the membrane resistance has a finite though small value during activity (Cole & Curtis, 1939). Instead of the expected result we found the action potential to be much larger than the resting potential. The first measurements were made with crustacean axons and external electrodes, but were not completely satisfactory because they did not give the absolute magnitudes of the potential difference across the nerve membrane. A method of inserting microelectrodes into squid axons was developed, and direct measurements of action and resting potentials were obtained in the summer of 1939 (Hodgkin & Huxley, 1939). At about the same time, Curtis & Cole (1940) evolved a rather different technique for performing the same experiment, and in a subsequent paper (Curtis & Cole, 1942) concluded that the action potential exceeds the resting potential by a large amount. The present paper provides an independent confirmation of this conclusion and extends it to crustacean nerve fibres. All the experiments to be described were made in 1939 and the bulk of the paper was written in 1940. Our measurements were less extensive than those of Curtis & Cole, but the results obtained seem sufficiently important to justify independent publication.

APPARATUS AND METHOD

Preparation of fibre

The giant fibre in the first stellar nerve of *Loligo forbesi* was used. The best results were obtained with the fibres from large specimens (mantle length 10 in.), but usually the mantle was only 7 or 8 in. long. The diameter of the axons used varied between 450 and 550  $\mu$ .

The nerve trunk was tied near the ganglion and dissected out of the mantle as far as the first large branch of the giant fibre. Here the trunk was again tied and cut, and transferred to a dish

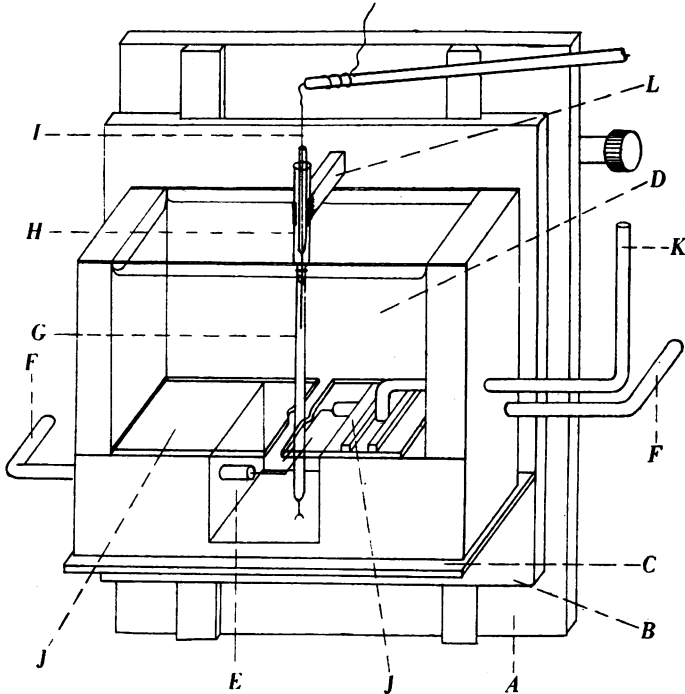

Text-fig. 1. Diagram of recording cell. *A*, fixed plate of mechanical stage of microscope. *B*, movable plate of mechanical stage. *C*, shelf attached to *B*. *D*, upper compartment of recording cell normally filled with sea water. *E*, lower compartment normally filled with oil. *F, F*, glass tubes conveying leads to stimulating electrodes. *G*, fibre. *H*, cannula. *I*, micro-electrode. *J, J*, glass plates forming partition between compartments. (The fibre passes through a hole formed by notches which have been ground in the edges of the glass plates.) *K*, handle for closing partition. *L*, holder for cannula. (An adjustable joint at the base of the holder is not shown.) The external electrode in the upper compartment and the arrangement of mirrors shown in Text-fig. 3 have been omitted.

of sea water. In the first experiments the whole length of the fibre was cleaned, but later only a short length at one end was cleaned for the insertion of a cannula. In either case, when the dissection was finished, the axon was cut half through with a fine pair of scissors, and a cannula inserted and tied in with a silk thread. A fine loop of platinum wire was attached to the free end of the fibre. This acted as a weight and made the fibre hang vertically in the recording cell. The dissection and cannulation took about 2 hr., and were carried out under a binocular dissecting microscope.

*Special apparatus.*

A solidly built microscope, with its optical axis horizontal, was clamped to the baseboard of a micromanipulator. The transverse movement of the mechanical stage was removed, and a horizontal shelf was fixed to the vertically moving plate of the stage. A recording cell, shown diagrammatically in Text-fig. 1, rested on this shelf.

The recording cell consisted of two compartments separated by a glass partition which could be opened or closed by a handle passing through the wall of the cell. The lower, smaller compartment contained the platinum-wire stimulating electrodes and was always filled with medicinal paraffin oil. The upper compartment could be filled with either sea water or paraffin; in the former case, the glass partition prevented the oil in the lower compartment from floating to the surface.

The microelectrode usually employed is shown in Text-fig. 2*a*. It consisted of a glass capillary about 4 cm. long. One-half of this had an external diameter slightly less than 0.1 mm. while the other was about 0.5 mm. in width. A 20 $\mu$ . diameter silver wire was passed to within about 1.5 mm. of the tip, the capillary was filled with sea water and the wire coated electrolytically with silver chloride.

This type of electrode had an electrical resistance of about 50,000 ohms. A different form of electrode is shown in Text-fig. 2*b*. This electrode gave a steadier potential, but it had an inconveniently high resistance (about 2 megohms) and was only used on one occasion. The microelectrode was suspended by a short length of wire from the tip of a glass rod held in one of the micromanipulator carriages.

Sea water was normally used in the upper compartment, and in this case the external electrode consisted of a chloride coated coil of silver wire immersed in the sea water. When paraffin oil was used, an agar wick electrode was brought into contact with the outside of the fibre opposite the tip of the microelectrode.

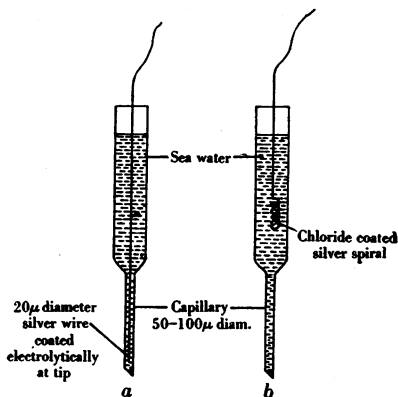

Text-fig. 2. Types of microelectrode employed.

*Procedure*

The fibre was transferred to the recording cell when the dissection and cannulation were complete. The cannula was attached to a clip which was mounted on the vertically moving plate of the microscope by means of a small universal joint. This was adjusted until the fibre hung vertically with its far end in the paraffin oil in the lower compartment of the recording cell. The partition was closed, and the upper compartment was filled with sea water. The stimulating electrodes were brought into contact with the fibre.

The vertical movement of the stage and the mount of the cannula were then adjusted so that the tip of the cannula was in the field of the microscope, which was fitted with a 2 in. objective. The microelectrode was lowered into the cannula by means of the micromanipulator till its tip was also visible. The mechanical stage was then racked up, raising the cell and cannula, and thus drawing the fibre up round the microelectrode, whose tip remained in the field of view. If one side of the fibre began to approach the microelectrode too closely, the cell was moved horizontally in that direction. Since the lower end of the fibre passed through the small gap left between the two pieces of the partition, this manoeuvre carried that side of the fibre away from the microelectrode.

It was still impossible, however, to tell when the microelectrode was in danger of touching the front or back of the fibre, and at first about half the fibres were spoilt by this accident. A pair of small mirrors made of pieces of coverslip backed with air, were therefore mounted as in Text-fig. 3, so that a side view of the fibre was seen in the field of the microscope at the same

time as the front view. There is no particular virtue in the use of airbacked mirrors, and the only reason for employing them was that front-silvered mirrors were not available. The mirrors were attached to a glass rod held in the second micromanipulator carriage. With this technique it was possible to ensure that the microelectrode did not touch the surface of the nerve fibre at any point. Photographs showing the microelectrode in position are reproduced on Pl. 1.

The giant fibre was stimulated repetitively during the process of lowering a microelectrode into its interior. A small action potential was observed while the microelectrode was still inside the cannula and this gradually increased as the electrode was lowered, until it reached a constant amplitude at a distance of 10 mm. from the cut end.

*Electrical recording system*

Potentials were recorded by means of a cathode-ray oscillograph and a balanced direct-coupled amplifier. This was designed for us by Dr Rawdon Smith of the Psychological Laboratory, Cambridge, and proved completely satisfactory. Calibrations showed that the amplifier response was constant to within less than 5% between 0 and 10,000 cyc./sec. In order to keep the input impedance as high as possible, the recording leads were connected to the grids of two valves which were placed about 6 in. from the preparation. These valves were arranged as cathode followers and produced no amplification; they were used solely as an impedance matching device. Calibrations of the input stage and the amplifier were made with electrically generated rectangular pulses.\* The wave form of these pulses was first tested by applying them directly to a cathode-ray oscillograph. This showed that the deflexion was 90% complete in 10μsec. The pulses were then reduced in amplitude by a low-resistance attenuator and fed into the input of the amplifier. Under these conditions the deflexion was 90% complete in 20μsec. Hence the amplifying system was sufficiently rapid to follow an action potential lasting 500–1000μsec.

The d.c. resistance of the input stage was of the order of 10<sup>10</sup> ohms and the grid current 10<sup>-10</sup>–10<sup>-11</sup> amp. The a.c. input impedance was mainly determined by the stray capacity of the grid lead which was less than 20μμF. A stray capacity of this magnitude might have introduced a serious error, if the action potential had been recorded through a resistance of several megohms, but it was of no importance in our experiments, because the total resistance of preparation and electrodes was less than 100,000 ohms.

The linearity of the amplifier was checked by applying a voltage which could be varied between 0 and 100 mV. in steps of 1 mV. This test showed that the deflexion of the oscillograph was directly proportional to the input to within 5% over the range of voltages used experimentally.

The standard voltages used for calibrating the oscillograph were obtained by passing a current of 100μa. through Muirhead decade resistances. The current was set to exactly 100μa. with a microammeter which had previously been calibrated by means of a Weston standard cell and decade resistances. All the resistances used had been tested by the National Physical Laboratory and were correct to within 0.1%.

Brief thyatron discharges were used for stimulating. These were synchronized with the sweep circuit and applied to the nerve through a small transformer.

\* The pulse-generating apparatus was built up by Dr Rushton, and these calibrations were made while one of us was collaborating with him in another research.

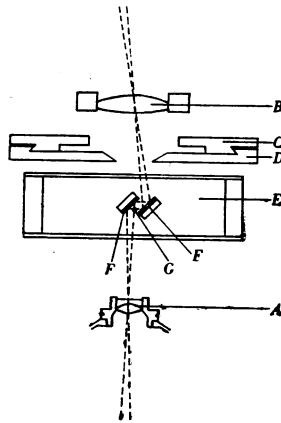

Text-fig. 3. Diagram of optical arrangement, seen in plan. A, 2 in. objective in tube of microscope. B, low-power condenser in substage. C, fixed plate of mechanical stage. D, movable plate of mechanical stage. E, recording cell. F, F, mirrors. G, axon. The paths for the central rays for the two images of the fibre are shown as dotted lines.

## EXPERIMENTAL RESULTS

*Preliminary experiments with internal electrodes*

As soon as the method of inserting microelectrodes began to be successful, tests were made to see if the presence of an internal electrode caused any change in the activity of the fibre. An axon was set up in oil as shown in Text-fig. 4 and potentials were recorded between electrodes *A* and *B*. *A* was a conventional type of external electrode, while *B* behaved like an external electrode in contact with the cut end of a nerve fibre. The record obtained from these two electrodes was an ordinary monophasic action potential whose magnitude depended upon the amount of short-circuiting introduced by the external fluid. Action potentials were recorded before and after the introduction of the microelectrode, and the magnitudes of the two potentials compared. A typical result was as follows:

Action potential before insertion of microelectrode = 28.5 mV.

After insertion = 28.25 mV.

The difference between the two action potentials was within experimental error, and in some experiments the recorded potential was actually slightly greater after the insertion of the microelectrode. This test indicated that the microelectrode had little effect on the activity of the axon. Further confirmation of this point came from the fact that the action potential was conducted without decrement for a considerable distance beyond the tip of the microelectrode. In one experiment a normal action potential was recorded at a distance of 9 mm. above the tip of the electrode.

*Size of microelectrode*

At an early stage in the investigation we made experiments to determine the optimum size for the microelectrode. Large electrodes are convenient, because they are easy to make and have a low electrical resistance; on the other hand, they are more likely to damage the axon than small ones. In order to find out how large an electrode could be tolerated, we prepared a series of glass rods with diameters of 30, 70, 100 and 170  $\mu$ . These were inserted into the inside of the axon and the external action potentials recorded in the usual way. The 170  $\mu$ . rod produced a 10% decrease in the size of the action potential, but the smaller rods had no effect on the magnitude of the potentials.

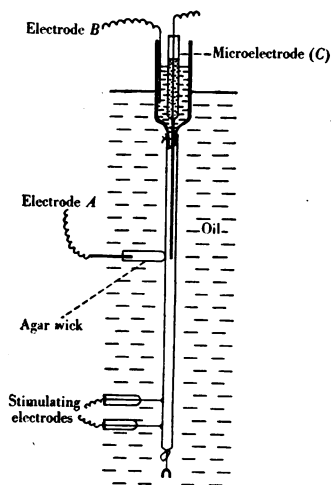

Text-fig. 4. Diagram of arrangement used for recording external action potentials.

We concluded from this experiment that it was safe to use electrodes with diameters up to about  $100\mu$ . At first it seems remarkable that an electrode with a diameter equal to one-fifth of that of the axon should have no effect on the activity of the axon. However, the volume of axoplasm displaced by such an electrode would be very small, since the cross-sectional area of the fibre is twenty-five times greater than that of the electrode. When a micro-electrode is inserted, it must either displace axoplasm into the cannula or cause the axon to swell. The second alternative is probably correct, since there was no indication of a flow of axoplasm into the cannula. We did not notice any change in diameter, but this is not surprising since the increase would not have amounted to more than 2% of the axon diameter.

*Comparison of action potential obtained with  
internal and external electrodes*

With the arrangement of Text-fig. 4 it was easy to compare the magnitudes of the action potential recorded with internal and external electrodes. A typical result was as follows:

Axon in oil: Action potential recorded externally from electrodes  
A and B = 28 mV.

Action potential recorded across membrane from elec-  
trodes A and C = 72 mV.

In this experiment the axon was left with considerable amounts of material attached to it. Hence the potential recorded with external electrodes was greatly reduced by short-circuiting effects.

One great advantage in using an internal electrode is that the axon can be kept in sea water and need not be surrounded by an insulating material. With external electrodes no action potential can be recorded from an axon immersed in sea water; with an internal electrode the potential is recorded directly across the membrane and is independent of the external resistance. This is illustrated by a continuation of the experiment just described. The oil was replaced by sea water and the potential recorded again:

Axon in oil:            Action potential recorded across membrane = 72 mV.

Axon in sea water: Action potential recorded across membrane = 74 mV.

*Characteristics of the action potential*

When the microelectrode had been inserted, it was a simple matter to obtain the absolute magnitude of the action potential. The fibre was stimulated at the lower end and the response measured directly on the oscillograph screen or recorded photographically. The amplitude of the action potential was then obtained by calibrating the oscillograph with a known input voltage. Errors which might have arisen from non-linearity of the amplifier were

avoided by increasing the calibrating voltage until it gave a deflexion equal to that produced by the action potential. The results obtained with ten axons are given in Table 1. Some of these fibres were in poor condition and therefore gave small action potentials. Those which produced potentials greater than 80 mV. appeared to be in perfect condition for they remained excitable and transmitted impulses for many hours.

TABLE 1. Action and resting potentials recorded with a microelectrode. The potentials tabulated are those obtained at the beginning of each experiment

Axon	Action potential mV.	Resting potential mV.	Positive after potential mV.
1	57	—	—
2	95	47	15
3	79	42	13
4	71	30	—
5	58	—	—
6	65	—	—
7	80	—	—
8	68	35	—
9	86	47	15.7
10	92	46	15

A typical record of an action potential, with an amplitude of 85 mV., is shown on Pl. 2. Here the negative phase of the action potential lasts for 0.7 msec. and is followed by a positive phase with an amplitude of 14 mV. and a duration of about 2.5 msec. This positive phase has been observed by everyone who has worked with squid axons (Cole & Curtis, 1939; Hodgkin, 1939; Pumphrey, Schmitt & Young, 1940). At first it was thought to be a diphasic artifact arising at the cut end of the axon. However, as Curtis & Cole (1940) have pointed out, the fact that it can be recorded with an internal electrode proves that it must be a genuine part of the response.

#### *The resting potential*

The measurement of the resting potential was complicated by the fact that the electrode potential of the microelectrode was not always the same as that of the external electrode. The potential difference (p.d.) between the two electrodes usually remained constant, but it could not be relied on and it was necessary to check the electrode p.d. at frequent intervals during the course of an experiment. The following procedure was therefore adopted. The microelectrode was placed in the sea water outside the axon and its potential measured against the external electrode. It was then removed from the sea water and lowered through the cannula into the axon. As the electrode was inserted, its potential became increasingly negative until it reached a constant value at a distance of about 6 mm. from the cannula. Measurements were usually made at a distance of 8–9 mm. from the cannula. As soon as values for the action and resting potentials had been obtained, the microelectrode was withdrawn, replaced in sea water and its potential remeasured.

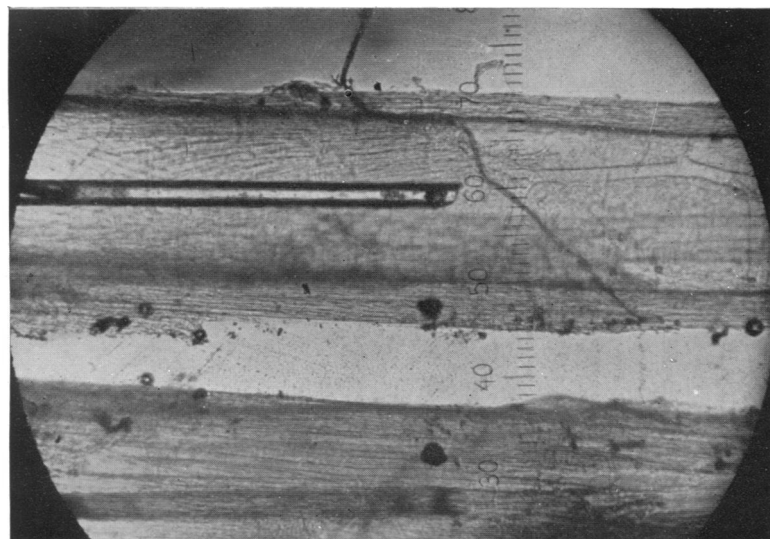

(b)

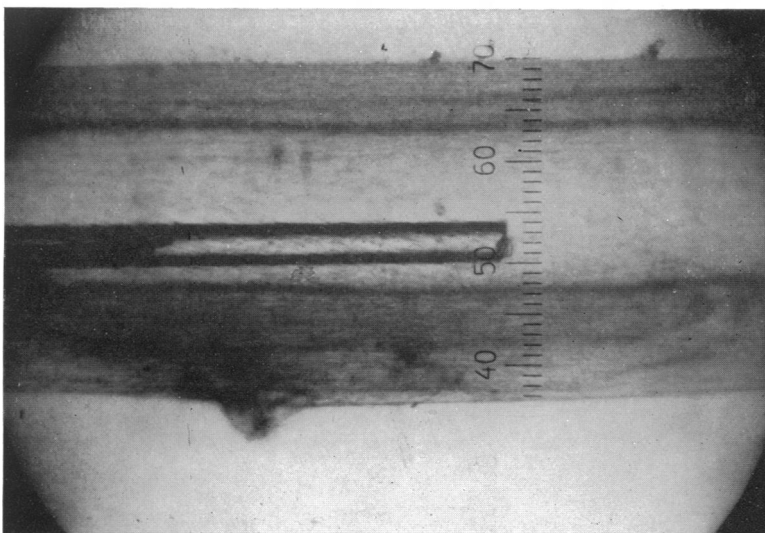

(a)

Photomicrographs of electrodes inside giant axon. Adjacent tissues have not been completely removed from the giant fibre which shows as a clear space. One scale division equals  $33\mu$ . (a) Photomicrograph taken without double mirror device. (b) Photomicrograph taken with double mirror. The right-hand image is formed directly by the microscope, while the left-hand image is a side view seen in the small mirror.



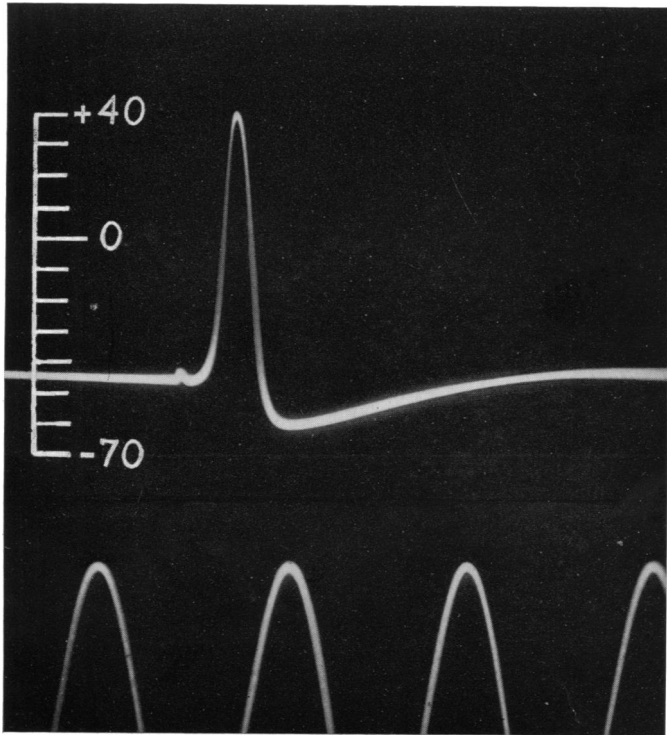

Action potentials recorded between inside and outside of axon. Time marker 500 cyc./sec. The vertical scale indicates the potential of the internal electrode in millivolts, the sea water outside being taken as at zero potential.

This was done in order to make certain that the electrode potentials had not altered during the course of the experiment. The resting potential was obtained from the difference between the potential of the microelectrode inside the fibre and its potential in the sea water. This method proved quite satisfactory, and values obtained in successive tests agreed reasonably well with one another. The following measurements were taken from an experiment in which the microelectrode was inserted and withdrawn on four successive occasions:

Resting potential (mV.)	Action potential (mV.)
44	83
41	81
41	81
44	83

Values for resting potentials obtained from six axons are given in Table 1. These results show that the resting potential was always much smaller than the action potential. The two sets of measurements are strictly comparable, since they were obtained at the same time and from the same point on the axon.

The difference between resting and action potentials is illustrated by Pl. 2. Here the resting potential was found to be 44 mV. Experimentally, this means that when the microelectrode was withdrawn and placed in the surrounding sea water, the oscillograph beam moved from the resting level to the point marked zero on the record. On the other hand, when the fibre was excited the deflexion overshoot the resting level and the microelectrode then became 40 mV. positive to the surrounding sea water.

#### *Experiments with external electrodes*

Further evidence for the conclusion that the action potential overshoots the resting potential is provided by experiments with external electrodes. Using this technique, measurements were made on the nerve fibres of crabs and lobsters as well as of squids. A typical experiment with an axon from the lobster (*Homarus vulgaris*) is summarized below. A length of about 3 cm. of a 70  $\mu$ . axon was dissected from the nerve trunk in the meropodite of one of the walking legs of a lobster. It was then set up in an electrode assembly and immersed in paraffin oil. The general characteristics of the electrode system were similar to those described in an earlier paper (Hodgkin, 1938) except that silver-silver chloride electrodes terminating in agar wicks were used in place of fine platinum wires. Stimulating and recording electrodes were arranged in the manner shown in Text-fig. 5a. At the beginning and end of the experiment a test was made to find if there was any residual p.d. between the electrodes. This was done by immersing both electrodes in sea water and recording the p.d. between them. The p.d. was found to be less than 0.4 mV. and could therefore be ignored. In order to observe action

potentials, the electrode assembly was raised into the layer of paraffin oil and the fibre stimulated repetitively. The record obtained is shown in Text-fig. 5*b*.

The resting potential at *A* was 5 mV. positive with respect to *B*, an asymmetry which can probably be attributed to the proximity of the cut end of the axon. When the action potential travelled along the nerve fibre, electrode *A* first became 56 mV. negative to *B*; later the potential wave reached *B* which

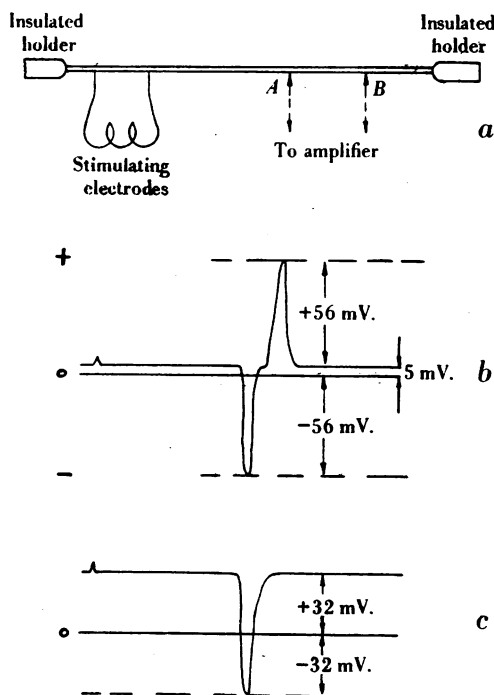

Text-fig. 5. Resting and action potentials in *Homarus* axon. Experiment of 16 July 1939. (a) Diagram of electrode assembly. The distance between electrodes *A* and *B* was about 10 mm. (b) Sketch of action potential recorded on C.R.O. (voltage at *A*) - (voltage at *B*) shown as positive. Normal nerve at *A* and *B* electrodes. (c) As in (b) but with isotonic potassium chloride placed on electrode *B*.

then became 61 mV. negative to *A*. A drop of isotonic potassium chloride solution was then placed on the nerve at *B*. This caused a transient discharge of nerve impulses and a steady resting p.d. of 32 mV. between *A* and *B*. On stimulation, record *C* was obtained. The action potential at *B* had disappeared while that at *A* amounts to 64 mV. Hence the active nerve becomes 32 mV. negative to a part which has been depolarized with isotonic potassium chloride.

Figures from a similar experiment with a  $30\mu$ . diameter axon from *Carcinus maenas* are given in Table 2.

TABLE 2. Experiment of 15 February 1939. Electrode assembly as in Text-fig. 5a.  
The distance between electrodes A and B was about 7 mm.

Condition of nerve		Potential difference (mV.) A - B
Electrode A	Electrode B	
At rest	At rest	+ 3.2
Action potential	At rest	- 68
At rest	Action potential	+ 65
At rest	Isotonic KCl applied	+ 37.5
Action potential	Isotonic KCl applied	- 27.5

A typical result with a squid axon and external electrodes is seen in Table 3.

TABLE 3. Experiment of 8 August 1939. Electrode assembly as in Text-fig. 5a.  
The distance between electrodes A and B was about 15 mm.

Condition of nerve		Potential difference (mV.) A - B
Electrode A	Electrode B	
At rest	At rest	+ 7
Action potential	At rest	- 67
At rest	Action potential	+ 70
At rest	Isotonic KCl applied	+ 43.7
Action potential	Isotonic KCl applied	- 23.3

Several experiments were made in order to discover whether the axon was fully depolarized by the action of isotonic potassium chloride. The method employed was to observe the depolarization produced by various processes which might damage or destroy the nerve membrane and to compare the results obtained with that produced by isotonic potassium chloride. The following methods were tested:

- (1) Cutting half through a giant fibre.
- (2) Cutting clean through a giant fibre or crustacean fibre.
- (3) Crushing with fine forceps.
- (4) Application of chloroform solution.

No significant difference was observed between the results obtained by these four processes. The depolarization observed was always less than that produced by isotonic potassium chloride. In crustacean axons the difference between the two e.m.f.'s was about 4 mV., in squid axons it was sometimes as great as 10 mV. The difference is explained by Curtis & Cole's (1942) observation that isotonic potassium chloride reverses the membrane potential. Curtis & Cole obtained reversed potentials of 15 mV., but a smaller value would be recorded with external electrodes since the membrane potential would be reduced by the short-circuiting effect of the external fluid.

The distribution of potential in the fibres which had been treated with potassium chloride was rather complicated. The potassium chloride solution was applied to the outside of the nerve fibre, but did not replace the sea water in the wick electrodes. There was therefore a junction potential of approximately 4.5 mV. between the outside of the nerve fibre and the sea water in the electrode B (Text-fig. 5): the sign of this p.d. being such that the electrode was positive to the nerve. This was partly compensated by the junction potential between the potassium chloride

at *B* and the sea water round the normal nerve at *A*. The contribution of this e.m.f. to the total recorded potential must have been less than 4.5 mV., because of the short-circuiting effect of the interior of the nerve fibre. The reduction in potential can be assessed by applying the standard equations of cable theory, which indicate that the potential would be reduced in the ratio  $r_2/r_1 + r_2$ , where  $r_1$  and  $r_2$  are the resistances per unit length of the external fluid and the interior of the nerve fibre. Finally, there was the reversed p.d. across the membrane in the potassium chloride region. This may be taken as 15 mV., but its effect on the total recorded potential must have been reduced by the short-circuiting action of the external fluid in the ratio  $r_1/r_1 + r_2$ . The effect of these three different sources of e.m.f. can be assessed if an assumption is made as to the ratio of  $r_1$  to  $r_2$ . If  $r_1 = r_2$  the net p.d. amounts to 5.25 mV. If  $r_1 \gg r_2$  it amounts to 10.5 mV. In both cases the sign of the p.d. is similar to that observed experimentally.

The results of the experiments with external electrodes are summarized in Table 4. They indicate that the action potential is roughly 75% greater than the injury potential produced by isotonic potassium chloride solution. The difference between the action potential and the true resting potential must have been greater than this, since isotonic potassium chloride itself reverses the membrane potential.

TABLE 4. Results obtained with external electrodes. The injury potentials were produced by applying isotonic potassium chloride to the nerve fibre. The figures in the bracketed rows were obtained from different parts of the same nerve fibre. All the observations were made from records similar to that shown in Text-fig. 5c

Date of experiment	Type of axon used	Action potential mV.	Injury potential mV.
{ 3. ii. 39	Axon from <i>Carcinus maenas</i> , ca. 30 $\mu$ . in diameter	62	36
3. ii. 39	" "	62	42
3. ii. 39	" "	54	36
5. ii. 39	" "	55	39
9. ii. 39	" "	62	34
9. ii. 39	" "	73	37
10. ii. 39	" "	55	39
14. ii. 39	" "	49	28
15. ii. 39	" "	65	37.5
24. v. 39	Axon from <i>Homarus vulgaris</i> , ca. 70 $\mu$ . in diameter	52.5	36
16. vii. 39	" "	64	32
4. viii. 39	Axon from <i>Loligo forbesi</i> , ca. 500 $\mu$ . in diameter	78	49.5
8. viii. 39	" "	67	43.7
11. viii. 39	" "	54	36

#### *Comparison with the work of Curtis & Cole (1942)*

The experiments described in this paper are in general agreement with those of Curtis & Cole (1942), in that they show that the action potential overshoots the resting potential. But there is considerable difference between the numerical results obtained in the two sets of experiments with internal electrodes. The largest action potential recorded by us was 95 mV., whereas Curtis & Cole report action potentials as high as 168 mV. and give an average value of 105 mV. No certain explanation of the difference between the two sets of results can be offered. Curtis & Cole's experiments were probably carried out at a higher temperature, but this could not account for more than a fraction of the difference obtained. We are inclined to believe that the

axons studied by Curtis & Cole were in better condition than ours. The preparation of giant axons is a very difficult operation, and the percentage of nerve fibres in perfect condition is likely to be rather small. The action potential is known to be sensitive to fibre condition, and it is possible that none of the action potentials studied by us were really of normal size. Curtis & Cole made much more extensive studies and their results may have approached more closely to the normal.

The resting potentials obtained are in better agreement. Curtis & Cole's average value is 51 mV., whereas ours is 41 mV. Some of this difference must be attributed to the type of electrode employed. Curtis & Cole used isotonic potassium chloride in the microelectrode whereas we used sea water. Hence Curtis & Cole's results should have been higher by the junction potential (sea water-potassium chloride) which is approximately 4.5 mV.; the remaining difference of 5.5 mV. is not statistically significant.

DISCUSSION

The evidence described in this paper indicates that the membrane potential is reversed and that the inside of the nerve becomes positive during the passage of an impulse. The classical picture of nervous action must therefore be altered from the familiar form illustrated in Text-fig. 6a to that shown in Text-fig. 6b.

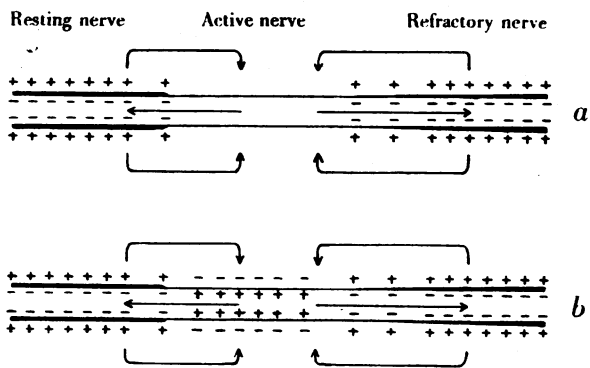

Text-fig. 6. Diagram illustrating (a) classical and (b) revised concepts of nervous activity.

Before accepting such a drastic revision of classical theory we shall do well to examine a more conventional explanation of the experimental results. The ionic composition of the interior of the nerve fibre is known to be very different from that of sea water (Webb & Young, 1940; Bear & Schmitt, 1939), so there should be a substantial junction potential between microelectrode and axoplasm. It can be argued that this junction potential might be of sufficient magnitude to reduce a membrane potential of 100 mV. to one of 50 mV., and in this way there seems at first some hope that the classical

picture of nervous activity can be retained. This argument fails for two reasons. In the first place it is very difficult to imagine how a junction potential of 50 mV. could be produced at the sea-water axoplasm interface, and still harder to account for the 100 mV. necessary to explain some of Curtis & Cole's (1942) results. In the second place we can show that such a junction potential would probably not influence the observed results even if it were of the right order of magnitude. According to the conventional membrane theory the nerve surface becomes freely permeable to all ions during activity and can so contribute nothing to the recorded p.d. The active nerve may therefore be considered as a symmetrical cell in which sea water makes contact with axoplasm both at the boundary of the microelectrode and at the surface of the nerve. The junction potentials at these two surfaces must therefore cancel one another, and no p.d. should be recorded between the inside and outside of the axon.

A qualitative explanation of the reversal of potential can be obtained if it is assumed that the surface membrane changes from a condition of rest in which it is permeable only to  $K^+$  to one of activity in which it is freely permeable to  $K^+$  and  $Na^+$  but not to  $Cl^-$ . In this case there would be a diffusion potential across the surface membrane and an uncompensated junction potential between axoplasm and sea water at the boundary of the microelectrode. If the former potential were smaller than the latter, or of opposite sign, the p.d. recorded during activity would be reversed. The extreme magnitude of this effect can be assessed in the following way. Consider first the junction potential between sea water and axoplasm. The approximate concentrations of  $K^+$ ,  $Na^+$  and  $Cl^-$  are known (Webb & Young, 1940; Bear & Schmitt, 1939), but there is a deficit of anions which is usually taken to indicate the presence of a large fraction of organic anions in the cell. For the purposes of calculation Curtis & Cole (1942) assume that these anions are monovalent and that their mobilities are such as to make the conductivity of axoplasm equal to its measured value, the mobilities of the remaining ions being taken as equal to those in sea water and their concentrations as equal to those reported by Bear & Schmitt (1939). With these assumptions they conclude that the junction potential  $E_{\text{isotonic } KCl} - E_{\text{axoplasm}}$  would be +6 mV. This indicates that the junction potential  $E_{\text{sea water}} - E_{\text{axoplasm}}$  would be about +10.5 mV. We made a similar calculation, but assumed that the missing anions had zero mobility and that the concentrations of the remaining ions were equal to those reported by Webb & Young (1940). Ionic mobilities were taken as equal to those in sea water, and Henderson's equation was used for computation (Henderson, 1907, 1908). These assumptions gave a value of +19 mV. for the junction potential  $E_{\text{sea water}} - E_{\text{axoplasm}}$ . A minimum value for the residual p.d. across the hypothetical active membrane can be calculated if it is assumed that the selective permeability of the membrane to

$\text{Na}^+$  and  $\text{K}^+$  is entirely lost, and that the mobilities of these ions in the membrane are in the same ratio as those in water. With these assumptions we find that the active membrane potential would be about 7 mV., if the concentrations of  $\text{K}^+$  and  $\text{Na}^+$  inside the axon are as reported by Webb & Young (1940). The sign of this potential is such that the inside of the axon would be negative to the outside. We can now assess the total p.d. which would be established between external and internal electrodes. If we take a figure based on Curtis & Cole's (1942) calculation for the junction potential we find that the residual p.d. would be  $7 - 10 \cdot 5 = -3 \cdot 5$  mV. If our figure is taken it would be  $7 - 19 = -12$  mV. In both cases the sign of this p.d. would be such as to produce a reversal of e.m.f. during activity, but its magnitude would be quite insufficient to explain the 45 mV. recorded by us or the 100 mV. difference reported by Curtis & Cole. We must therefore conclude that the difference between action and resting potentials indicates a real reversal of potential at the surface membrane as indicated in Text-fig. 6*b*.

Four types of explanation can be advanced to account for the reversal of membrane potential during activity. These may be classified in the following way:

- (1) The active membrane becomes selectively permeable to anions which are present in the axoplasm, but are in low or zero concentration in sea water.
- (2) Activity involves a change in the orientation of dipoles in the surface membrane.
- (3) Explanation in terms of apparent membrane inductance.
- (4) Series capacity hypothesis.

The first hypothesis is self-explanatory. As an example, let us assume that the axoplasm contains a large quantity of lactate in ionic form and that the membrane becomes freely permeable to these ions during activity. An alternative assumption is that the membrane does not change at all during the passage of an impulse and that activity consists in the liberation of an anion with high mobility in the membrane. In either case, anions would tend to diffuse out of the axon, but would be restrained at the surface membrane; hence a membrane potential of reversed sign would be set up. Such a state of affairs is theoretically possible, but does not seem at all probable, since it is hard to imagine that the concentration or mobility of lactate or any other organic ion would be sufficient to swamp the contributions of  $\text{K}^+$  and  $\text{Cl}^-$  to the membrane potential.

The second hypothesis is based upon the fact that monomolecular films of fatty acids may change the p.d. of the air-water interface by several hundred millivolts. The direction of the p.d. indicates that the polar end of a fatty acid is negative with respect to the paraffin chain. The cell surface could not consist of a monomolecular film of fatty acid, since a single layer of fatty acid molecules would be unstable in contact with two aqueous phases. But



it might be composed of a bimolecular film of fatty acid or lipid molecules orientated in the manner shown in Text-fig. 7 (see Danielli, 1936, and others). Protein molecules are almost certainly present as well as lipids, but have been omitted for the sake of simplicity. The orientated dipoles in a system of this kind would give rise to potential gradients at each side of the membrane. The two gradients would be of opposite sign and could therefore contribute little to the resting membrane potential. Even if the gradients were dissimilar they could make no permanent contribution to the resting potential, since ions are free to move through the surface, and would neutralize a p.d. arising from a purely static orientation of dipoles. But a transient wave of negativity would occur if the inner layer of dipoles were removed, or deorientated in some way when the membrane was excited. The duration of this wave would depend upon the rate at which the membrane capacity was discharged by

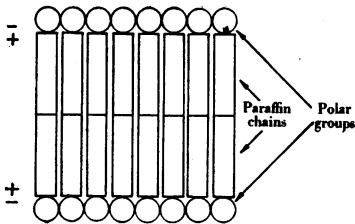

Text-fig. 7.

Text-fig. 7. Diagram showing hypothetical membrane composed of bimolecular layers of fatty acid. Positive and negative signs indicate the main potential gradients associated with each layer of molecules.

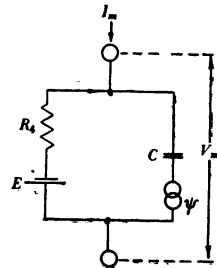

Text-fig. 8.

Text-fig. 8. Hypothetical equivalent circuit of nerve membrane.

ions, and the time constant of this process should be the same as the electrical time constant of the whole membrane. The time constant of the resting membrane in the squid axon is about  $500\mu\text{sec.}$ , while that of an active one is about  $25\mu\text{sec.}$  (see Cole & Curtis, 1939; Cole & Hodgkin, 1939; Cole, 1941). The time scale of the process is therefore of the right order of magnitude to explain the overshoot of the action potential provided that the membrane e.m.f. is sufficiently large and develops sufficiently rapidly. The p.d. arising from a fatty acid such as butyric acid has a maximum value of about  $350\text{mV.}$ , while values in excess of  $600\text{mV.}$  have been recorded from such compounds as triethylamine (Rideal, 1930). It therefore seems reasonable to suppose that an action potential of  $100\text{mV.}$  might arise in this way. An exact formulation of this theory is impossible, but it may be examined from a slightly more quantitative point of view. Let us assume that the action potential arises solely from changes in molecular orientation and that the nerve membrane has the equivalent circuit shown in Text-fig. 8. The resting membrane

e.m.f. is represented by the battery  $E$ , the voltage due to orientated dipoles by a variable  $\psi$ , the total p.d. across the membrane by  $V_m$ , and the current through it by  $I_m$ ;  $R_4$  and  $C$  are the membrane resistance and capacity respectively. These quantities are related in the following way:

$$I_m = \frac{V_m - E}{R_4} + \frac{Cd(V_m - \psi)}{dt}, \quad (1)$$

where  $I_m$  is the membrane current density in amp. cm.<sup>-2</sup>,

$C$  is the membrane capacity in F. cm.<sup>-2</sup>,

$R_4$  is the membrane resistance in ohms cm.<sup>2</sup>,

$E$  and  $V_m$  are expressed in volts and  $t$  in seconds.

An approximate estimate of the value of  $d\psi/dt$  at the crest of the action potential wave can be made in the following way. By definition  $dV_m/dt$  is zero and  $V_m - E$  is equal to the peak amplitude of the action potential wave which may be taken as  $-100$  mV. According to Cole & Curtis (1939)  $R_4$  is about  $25$  ohms cm.<sup>2</sup> at the height of activity while  $C$  remains constant at about  $1\mu$ F. cm.<sup>-2</sup>.  $I_m$  can be obtained from the second derivative of the action potential wave to which it is related by equation (2) when the fibre is immersed in a large volume of sea water:

$$I_m = \frac{\rho}{2R_2} \frac{d^2V_m}{dx^2}. \quad (2)$$

In this expression  $x$  is distance along the fibre in cm.,  $\rho$  is the radius of the fibre in cm., and  $R_2$  the specific resistance of the axoplasm in ohms cm. Measurement of the peak of an action potential from an axon of radius  $250\mu$ . indicated that  $d^2V_m/dx^2$  was about  $0.5$  V. cm.<sup>-2</sup>  $R_2$  was taken as  $30$  ohms cm., this being approximately the value found by Cole & Hodgkin (1938). Hence  $I_m \doteq 0.2 \times 10^{-3}$  amp. cm.<sup>-2</sup>. When these values are substituted in equation (1),  $d\psi/dt$  is found to be  $-4.2 \times 10^3$  V. sec.<sup>-1</sup>. This result indicates that the rate of change of molecular orientation would be equivalent to that produced by a dipole layer with a potential difference of  $420$  mV. collapsing during a period of  $0.1$  msec. This is not an impossible assumption, although it is a little hard to imagine that such a change would leave the membrane capacity unaltered during activity.

A different type of explanation was put forward by Curtis & Cole (1942) to account for the difference between action and resting potentials. Their explanation is based upon the fact that the axial impedance of a squid axon appears to contain an inductive component (Cole & Baker, 1941). The inductance seems to be localized in the surface membrane and has a value of approximately  $0.2$  H. The quantitative results obtained were consistent with the assumption that the equivalent circuit of the membrane is similar to that shown in Text-fig. 9a (Cole, 1941).  $C$  is the fixed capacity of  $1\mu$ F. cm.<sup>-2</sup>, while  $R_4$  is a variable resistance which represents the rectifier element in the

nerve surface. Cole (1941) has shown that the equivalent circuit of Text-fig. 9*a* provides a possible explanation of the subthreshold response of a nerve fibre to rectangular pulses of direct current. When an anodic polarizing current or a weak cathodic one is applied,  $R_4$  remains high enough to damp out the effect of  $L$ . But at larger cathodic currents  $R_4$  ceases to mask  $L$  and the response shows a hump or local action potential which increases and tends to become oscillatory as the threshold is approached. The frequency of the oscillations is of the order of 400 cyc./sec. Cole suggests that the inductance may arise from a piezo-electric effect in the membrane; but as he points out, no ordinary piezo-electric system could have a natural frequency as low as 400 cyc./sec. We are reluctant to accept the idea of a genuine inductance in the membrane, since it is difficult to attach any physical significance to such

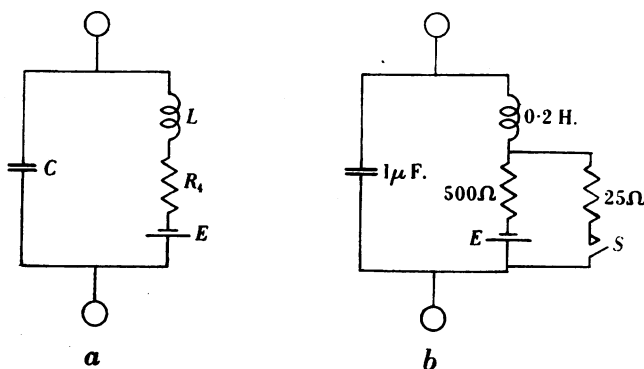

Text-fig. 9.

a concept. But an inductive element certainly offers an attractive explanation of the difference between action and resting membrane potentials. In order to illustrate how inductance might cause the action potential to overshoot the resting potential we assumed that the membrane had the structure of Text-fig. 9*b* and that excitation consisted in the closing of the switch  $S$  for a certain length of time. The potential waves resulting from three different periods of switching have been calculated and are given in Text-fig. 10. In the three cases considered, the reversed p.d. across the network is 80% of the battery voltage  $E$ . The action potential of nerve is much more complicated in its origin, but the simple model of Text-fig. 9*b* illustrates how inductance could cause the action potential to overshoot the resting potential. It also shows how an inductive element could explain the positive after potential.

The last explanation to be discussed will be called the series capacity hypothesis. It assumes that the resting membrane e.m.f. is in series with the membrane capacity instead of being in parallel with it as is normally supposed. The resting membrane is considered to have the structure shown in Text-fig. 11*a*. In the vicinity of an active region the p.d. across the membrane is

reduced, and for the purpose of this argument we shall assume that it is reduced to zero before excitation occurs. The membrane capacity will therefore acquire a reversed voltage  $-E$  (Text-fig. 11 *b*), and this will persist when the excitation occurs and the battery  $E$  disappears (Text-fig. 11 *c*). A reversed

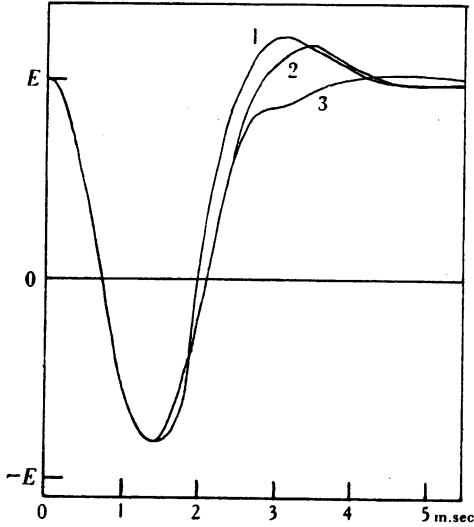

Text-fig. 10. Response of network shown in Text-fig. 9 *b* to closure of switch. Curves show voltage ( $V$ ) across network when switch is closed for following times. Curve 1: from  $t=0$  to 1.4 msec. Curve 2: from  $t=0$  to 2.13 msec. Curve 3: from  $t=0$  to 2.8 msec. Initial boundary conditions taken as  $V=E$  and  $dV/dt=0$  when  $t=0$ .

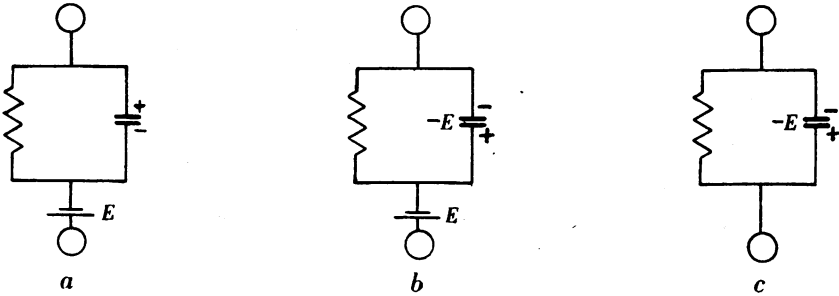

Text-fig. 11.

action potential could arise in this way and should be capable of reducing adjacent parts of the nerve membrane to zero p.d. as was assumed initially. This hypothesis has not been developed in any detail and may not bear quantitative investigation. But it has one point in its favour. The membrane capacity is thought to correspond to a dielectric at least 20  $\mu$ . thick, whereas the voltage gradient may occupy only a few  $\mu$ . The gradient is in any case

likely to be greatest at the edges of the dielectric and may conceivably have a low value over a large part of it. The idea of an e.m.f. in series with a capacity is therefore reasonable from a physical point of view.

#### SUMMARY

1. A technique is described for introducing microelectrodes into the interior of giant axons from the squid (*Loligo forbesi*).

2. Action potentials recorded externally were not affected by the introduction of a microelectrode 100  $\mu$ . in diameter.

3. The action potential recorded across the surface membrane was not altered by changing the fluid surrounding the fibre from oil to sea water.

4. The amplitude of the action potential was found to be about twice that of the resting membrane potential. The largest action potentials recorded were about 90 mV., whereas the corresponding resting potentials were about 45 mV. All measurements were made with a microelectrode containing sea water at its tip, so that there must have been a junction potential between the axoplasm and the microelectrode. The true resting potential across the surface membrane was probably about 60 mV.

5. Measurements with external electrodes were made on single nerve fibres from crabs (*Carcinus maenas*) and lobsters (*Homarus vulgaris*) as well as on squid axons. These results showed that the action potential was about 75% greater than the injury potential produced by isotonic potassium chloride. The difference between the action potential and the true resting potential must have been greater than this, since isotonic potassium chloride itself reverses the membrane potential.

6. The difference between action and resting potentials is too large to be explained by a liquid junction potential between the axoplasm and the microelectrode. It must be due to a genuine reversal of potential at the surface membrane of an active section of nerve. Possible ways in which this reversal of potential might arise are discussed.

We wish to acknowledge our gratitude to the Rockefeller Foundation for an equipment grant which made this work possible.

#### REFERENCES

- Bear, R. S. & Schmitt, F. O. (1939). *J. cell. comp. Physiol.* **14**, 205.  
Cole, K. S. (1941). *J. gen. Physiol.* **25**, 29.  
Cole, K. S. & Baker, R. F. (1941). *J. gen. Physiol.* **24**, 771.  
Cole, K. S. & Curtis, H. J. (1939). *J. gen. Physiol.* **22**, 649.  
Cole, K. S. & Hodgkin, A. L. (1939). *J. gen. Physiol.* **22**, 671.  
Curtis, H. J. & Cole, K. S. (1940). *J. cell. comp. Physiol.* **15**, 147.  
Curtis, H. J. & Cole, K. S. (1942). *J. cell. comp. Physiol.* **19**, 135.

- Danielli, J. F. (1936). *J. cell. comp. Physiol.* **7**, 393.  
Henderson, P. (1907). *Z. phys. Chem.* **59**, 118.  
Henderson, P. (1908). *Z. phys. Chem.* **63**, 325.  
Hodgkin, A. L. (1938). *Proc. Roy. Soc. B*, **126**, 87.  
Hodgkin, A. L. (1939). *J. Physiol.* **94**, 560.  
Hodgkin, A. L. & Huxley, A. F. (1939). *Nature, Lond.*, **144**, 710.  
Pumphrey, R. J., Schmitt, O. H. & Young, J. Z. (1940). *J. Physiol.* **98**, 47.  
Rideal, E. K. (1930). *An Introduction to Surface Chemistry*. Camb. Univ. Press.  
Webb, D. A. & Young, J. Z. (1940). *J. Physiol.* **98**, 299.