

THE DIRECT MEASUREMENT OF THE PARTIAL
PRESSURE OF OXYGEN IN HUMAN BLOOD.
By J. BARCROFT AND M. NAGAHASHI.

(From the Physiological Laboratory, Cambridge.)

A DIRECT method for the measurement of the oxygen pressure in the arterial and venous blood of man is much to be desired. The following procedure in which there is little that is new, but which is rather a combination of ideas introduced at various times by a number of workers, Krogh⁽¹⁾, Barcroft and Hamill⁽²⁾, Brodie and Cullis⁽³⁾ and Stadie⁽⁴⁾, has given us results which seem satisfactory.

In principle, the method is as follows. Blood is withdrawn from a vessel, artery or vein by direct puncture; to this blood is exposed a small bubble of alveolar air at 37° C. until an equilibrium is established between the blood and the bubble. The bubble is then analysed in a suitable apparatus.

In detail the procedure is carried out as follows:—the blood to the volume of 10 c.c. or rather more is withdrawn by means of a syringe the needle of which must fit perfectly so that no air is sucked in at the junction. In our first experiments the air bubble was introduced into this syringe. We gave up this procedure for two reasons: (1) the syringe being lubricated with paraffin, a film of the oil separates the bubble from the blood and equilibrium takes place with difficulty. (2) The end of the syringe being flat inside, the bubble cannot be expelled with certainty when the time comes for its transference to the analyser. When the blood is withdrawn therefore it is at once transferred to an all glass syringe with a barrel sufficiently well ground to make it air-tight in use, and with a plunger conical at the end. As supplied by the maker the syringe terminates in a cone and ends abruptly at the level of the end of the plunger, there being no nozzle. On to this end was blown a small tap with 2 mm. bore tubing. The whole is represented in the figure.

This syringe is prepared for use in the following way. The plunger is taken out, the tap is shut, a few grains of hirudin are put into it, but not suffered to adhere to the sides. The plunger is moistened with saliva

and replaced. A little mercury is drawn into it. A nose-clip is put on the nose, the nozzle of the syringe with the tap open is put between the teeth, the lips are almost closed and a forced expiration is made, at the end of which the lips are completely closed and alveolar air from the mouth is drawn into the syringe and most of it expelled again. The lips are now opened and the syringe removed. The tap is opened ever so little and all the alveolar air in the syringe with the exception of $\frac{1}{10}$ c.c. is expelled. The syringe is now inverted so that the nozzle points downwards. The bubble rises, or if necessary is shaken above the mercury, the tap is opened and the dead space is filled with mercury from within the syringe.

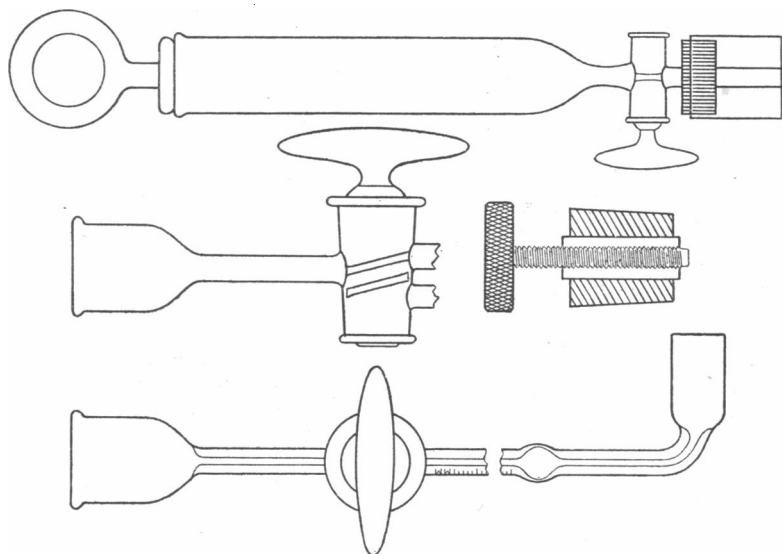

Fig. 1. Capillary gas analyser and saturator.

A small piece of 1 mm. bore rubber tubing is placed on the nozzle, the lumen of this is also filled with mercury. To this syringe the blood is transferred without exposure to air. It is rotated for ten minutes in a water bath at 37° C. and then the bubble is transferred to the gas analyser.

The method of transfer will be discussed later.

The analyser consists of a piece of glass tubing of 1 mm. bore at one end, the tubing is turned at right angles and broadens out into a small cup; at the other end is a three-way tap as shown in the figure. About a centimetre from the cup the lumen is expanded into a spherical chamber of about $\frac{2}{10}$ – $\frac{3}{10}$ of a cubic centimetre capacity. The portion of tubing

between this chamber and the tap is graduated in centimetres and millimetres on the glass. This portion should be about 17 cm. in length. Beyond the three-way tap is a cup of about 1.5 cm. diameter. Into this cup goes a well fitting rubber cork and through the cork a steel cylinder containing a screw plunger. Perhaps our greatest difficulty has been to obtain a sufficiently air-tight screw.

The analyser is prepared as follows:—the tap is shut, the cup filled to about one-half its capacity with mercury, the cork greased and put into its place (which of course causes some compression of the air in the cup). The apparatus is then inverted so that the thumb-screw is downward, the tap is then opened and the cork driven home. The air of course escapes and there should be enough mercury to fill the tube as well as the cup. The cork is then tied in its place by a piece of tape which passes round the tap and under the cork. If there is any air left in the cup or if there is too much mercury in it the undesired material may be expelled through the orifice of the tap which leads to the air. The apparatus now being full of mercury, a little water is put in the small cup, drawn into the tube by turning the thumb-screw and expelled. The object is to make a film of moisture on the inside of the graduated part of the tube. The analyser is now ready to receive the bubble.

In our first experiments the transfer was made over mercury by means of a convenient attachment which need not be described as the method was discarded subsequently. The bubble then being in the small inverted cup, is withdrawn into the tubing. The analyser is now removed. The small cup (which for the sake of distinguishing it from the large mercury cup, we shall call the gas cup) is placed with its orifice upwards, a few drops of special saline are put into it. The saline is drawn in. By dint of a little manipulation, the air bubble is withdrawn entirely into the graduated portion of the tube, whilst those portions of the apparatus between the bubble and the gas cup are filled with saline. The presence of mercury in this chamber is immaterial so long as it is not present in sufficient quantity to close the tubing and so exert a pressure on the bubble. The gas cup should be emptied of excess of fluid. The saline used is prepared as follows: a few drops of octyl alcohol are placed in Ringer's solution. As much of the alcohol as will is dissolved, the remaining droplets are removed with a separating funnel. This fluid is placed in a large flask fitted with a rubber cork, pierced by a piece of glass tubing on which is a tap. Into the air of the flask is forced a volume of carbonic acid equal to about 6 p.c. of that of the flask. The flask is then inverted and the saline can be obtained through the tap.

The length of the bubble is now measured. For this purpose the analyser is placed horizontally up to the tap in an unsilvered cylindrical vacuum flask. It is thus protected from the immediate incidence on it of radiant heat, and in an ordinary room of equable temperature the bubble in ten minutes or so settles down to a uniform length. Under the analyser and also in the vacuum flask is a slip of mirror in order to assist the observer to avoid parallax.

When the initial length of the bubble has been measured, it is expelled into the chamber, into which 10 p.c. KOH is then drawn. The bubble by the same process having been drawn back into the graduated tube. If this is done with the tube as nearly vertical as possible, the fluids in the chamber will appear to be in layers, the saline being above the potash.

By altering the position of the analyser so that the gas cup is at a higher level than the tap and then making the bubble pass into the chamber once more the layer of saline may be driven out and more KOH sucked in. In a few minutes the CO₂ will all have been absorbed from the bubble, water is made to replace the KOH, the tube as well as the chamber being washed and the bubble now free from carbonic acid is measured.

We have never been able to get what we regard as accurate readings for the CO₂. The apparent readings have always been too small. This we take to mean that CO₂ has been lost from the bubble in the initial manipulation when it was in contact with saline. The initial length of the bubble is therefore too short and a correction must be made for this loss with which we shall deal later. The absorption of oxygen with pyrogallic acid is carried out in the same way as that of CO₂ with KOH.

If A be the length of the bubble before pyrogallic acid, B that after the acid, C the corrected initial length of the bubble, P the height of the barometer and T the tension of aqueous vapour in the bubble as it existed in the syringe (47 mm. for 37° C.) and O the pressure of oxygen in the blood in the syringe

$$O = \frac{100(A - B)}{C} \times P - T.$$

In the case of arterial blood the initial length of the bubble is calculated on the assumption that the pressure of CO₂ in blood was that of the alveolar air. In venous blood we have assumed that it was 50 mm. unless the blood was either very red or very black, in which case, a special calculation on the basis of the respiratory quotient and the CO₂ dissociation curve may be made.

The first tests to which we put the above method were carried out at room temperature. About 12 c.c. of blood was put in a saturator with a mixture of oxygen, nitrogen, and carbonic acid. The blood and the gas were thoroughly shaken until equilibrium between the two was established. The blood was then withdrawn into the syringe and its oxygen pressure estimated. The gas in the saturator was also analysed. It is clear that the oxygen pressure in both cases should be the same. The following consecutive comparisons were obtained:

Pressure of oxygen in bubble mm.	Pressure of oxygen in tonometer mm.	Initial pressure of oxygen in bubble mm.
38	38	35
21	19	110
19	19	110
17.5	16.5	16.5

The above seemed to indicate, as was to be expected from Krogh's work, that the method was worth following up. We therefore endeavoured to repeat the tests, exposing the blood in the saturator to a temperature of 37° C. In these circumstances we found that the oxygen tension as measured by the bubble was below that in the saturator.

	Pressure of gas in bubble mm.	Pressure of gas in saturator mm.	Initial pressure of gas in bubble mm.
(1)	25	29	28
(2)	37	41	110 approx.
(3)	35	41	110 „

We attributed the loss of oxygen to the cooling of the blood to which the bubble was exposed during its transfer from the syringe to the analyser. The hæmoglobin at the lower temperature would tend to absorb oxygen from a gas with which it had been in equilibrium at 37° C.

We therefore so modified the method that the bubble was transferred at 37° C. The saline bath used for the rotation of the syringe was made of a glass jar large enough to submerge the syringe either in the horizontal or vertical position. A short piece of glass tubing, larger in diameter than the gas cup, was fitted with a cork so that it could be attached to the nozzle of the syringe. With it the bubble may be transferred as follows: the gas cup is filled with saline and inverted over the edge of the bath which for the present purpose became a pneumatic trough. The syringe was placed vertically with its nozzle inside the gas cup and the glass tubing outside, the tap on the syringe is then opened and the contents gradually expelled. The bubble of course comes out immediately

and is at once drawn into the analyser whilst a gradual stream of blood is kept running through the gas cup by pressure on the handle of the syringe. The following determinations were made in this way:

Pressure of oxygen in saturator mm.	Pressure of oxygen in bubble mm.	Initial pressure of oxygen in saturator mm.
47	46	110 approx.
31	28	110 "
51	53	51
41	45	45
51	53	110

From these determinations we passed to others upon blood withdrawn directly from the basilar vein.

In order to secure different degrees of venosity of the blood the arm was exposed, as has been done by previous workers, to different temperatures, either in one case hot water in others cold water or the temperature of the laboratory, whilst to secure the greatest degree of venosity the subject spent 15 minutes in the cold storage room prior to having his blood examined. The oxygen tension of the blood was measured by the bubble, whilst the percentage saturation of the same was measured with the differential apparatus.

The dissociation curve of blood of gradually increasing venosity has never actually been measured, but it has been calculated from theoretical data by Christiansen, Douglas and Haldane⁽⁵⁾. The following data which we obtained agree very closely with their calculations.

Dissociation curve of blood from basilar vein (Nagahashi).

Percentage saturation	Oxygen pressure observed	Oxygen pressure read from C., D. and H.'s curve, corresponding to p.c. saturation
95	92	92-72 mm.
92		
74.8	50	49.4
74.8		
61	38	38-37.4
59.2		
61.6	38	38.4-36.5
57.5		
15.8	14	16.7-15.2
13.7		

The above figures as well as confirming Christiansen, Douglas and Haldane's curve also confirm Meakins and Davies⁽⁶⁾ in their demonstration of the great range of venosity which may be obtained by exposing the skin of the arm to varying temperatures. Assuming the arterial blood to be 95 p.c. saturated and the venous blood to vary

between 93.5 and 15 p.c. saturation, the difference in percentage saturation between the arterial and venous bloods would vary between 1.5 and 80. If the metabolism of the skin were the same at the different temperatures—and there is at all events no reason to suppose that it is greater at the lower temperature—the above range of difference in the percentage saturations would correspond to something like a fifty-fold difference in the quantity of blood which traverses the skin.

The table illustrates the unsatisfactory nature of the attempt to determine the oxygen pressure from the percentage saturation when the latter is over 90 p.c. The difference between 92 p.c. and 95 p.c. saturation corresponds to a difference of 72 and 92 mm. respectively (or 20 mm.), whilst the difference between 61.6 and 57.5 p.c. saturation corresponds to a difference of less than 2 mm. oxygen pressure.

A sample of arterial blood drawn by direct arterial puncture gave an oxygen pressure of 99 mm., that in the alveolar air taken by Haldane and Priestley's method gave 101.8 mm. The slight difference has of course on a single determination no significance.

We wish to record our thanks to the Medical Research Council which bore a portion of the expense of the work and to Dr Bock who made the determinations of the percentage saturation of the blood.

SUMMARY.

1. By the method described it is possible to measure the oxygen pressure in blood drawn directly from a vessel in man to within about 2 mm. on the average.
2. The dissociation curves for venous blood calculated by Christiansen, Douglas and Haldane has been confirmed experimentally.
3. The observations of Meakins and Davies on the great range of unsaturation of blood from the basilar vein when the arm is exposed to widely differing temperatures have also been confirmed. Our experiments indicate a fifty-fold alteration in the volume of blood traversing the skin of the arm per minute.

REFERENCES.

- (1) Krogh. *Skand. A. f. Physiol.* 20. p. 279. 1908.
- (2) Barcroft and Hamill. *This Journal*, 34. p. 306. 1906.
- (3) Brodie and Cullis. *Ibid.* 36. p. 403. 1908.
- (4) Stadie. *Journ. Exp. Med.* 30. p. 215.
- (5) Christiansen, Douglas and Haldane. *This Journal*, 48. p. 262. 1914.
- (6) Meakins and Davies. *Journ. Path. and Bact.* 22. p. 451. 1920.