

# A British family with hereditary pancreatitis

J. R. SIBERT<sup>1</sup>

*From the Department of Child Health, Royal Victoria Infirmary, Newcastle-upon-Tyne*

**SUMMARY** A family with hereditary pancreatitis is described. Nine family members definitely have had pancreatitis, whilst 15 more are suspected of having the disease. The condition presents as recurrent attacks of epigastric or central abdominal pain, sometimes radiating to the back, often associated with vomiting. The attacks of pain usually last three to four days. The inheritance fits well with an autosomal dominant pattern with limited penetrance, as it does in other families described in the literature. There is no aminoaciduria as has been described in some previously reported families. The attacks of pain start in childhood or young adult life (mean age of onset in this family is 12.6 years) and appear to cease in this family by the age of 40 years. The diagnosis of pancreatitis in members of the family who have had confirmed pancreatitis was made by finding a raised serum amylase concentration in four cases, at laparotomy in four cases, and by pancreatic calcification seen on radiography in one case. The literature on the condition is reviewed, and it is speculated that the condition may have been underdiagnosed in Britain.

Pancreatitis occurring on a familial basis was first described by Comfort and Steinberg in 1952. This appeared to be inherited as an autosomal dominant condition with incomplete penetrance with an associated aminoaciduria of lysine and cystine. Gross and his coworkers from the Mayo Clinic described four other kindreds all with aminoaciduria (Gross and Comfort, 1957; Gross, Gambill, and Ulrich, 1962a; Gross, Ulrich, and Maher, 1962b). Several other families without aminoaciduria were described in America and France, establishing the condition as a disease entity (Davidson, Constanza, Swieconeck, and Harris, 1968; Logan, Schlicke, and Manning, 1968; Cornet, Dupon, Hardy, and Gordeef, 1962; Whitten, Feingold, and Eisenklam, 1968; Kattwinkel, Lapey, di Sant 'Agnese, and Edwards, 1973). The onset of hereditary pancreatitis is at an early age, often in childhood. Patients have no history of alcohol ingestion and present with recurrent attacks of abdominal pain.

In May 1972 at the Newcastle General Hospital, a 5-year-old girl presented with acute abdominal pain. This later proved to be due to pancreatitis at laparotomy (see figure, case D 29). Her maternal uncle, aunt, and mother also had pancreatitis. A report on these members of the family was published in 1973 (Sibert, 1973).

<sup>1</sup>Present address: Department of Child Health, Welsh National School of Medicine, Heath Park, Cardiff, CF4 4XN.

Received for publication 18 November 1974.

The grandmother (case B 8) of the little girl who presented (case D 29) was free of pain and had little contact with her relatives who lived outside Newcastle. It was initially thought that the pancreatitis gene was carried on the grandfather's side of the family. However, the interest the investigations had aroused in the Newcastle family revealed that a distant relative in Coventry (case D 23) had had pancreatitis. Subsequent personal visits, correspondence, and searching of hospital and general practice records disclosed nine family members with confirmed pancreatitis and 15 family members with abdominal pain which is suspected to be due to pancreatitis. This is the largest kindred described in Great Britain, and the inheritance is an autosomal dominant with incomplete penetrance.

## Case Reports

### CASES A 1 AND 2

Originated in the Bishop Auckland area of County Durham. Died aged 78 years and 80 years respectively of 'strokes'. They are not remembered by their children as having abdominal pain.

### CASE B 1 AND HER DESCENDANTS

Case B 1 is remembered by both her sons as having abdominal pain when young. She died aged 63 years of a carcinoma of the descending colon at the Leicester General Hospital. The notes unfortunately have been destroyed by fire.

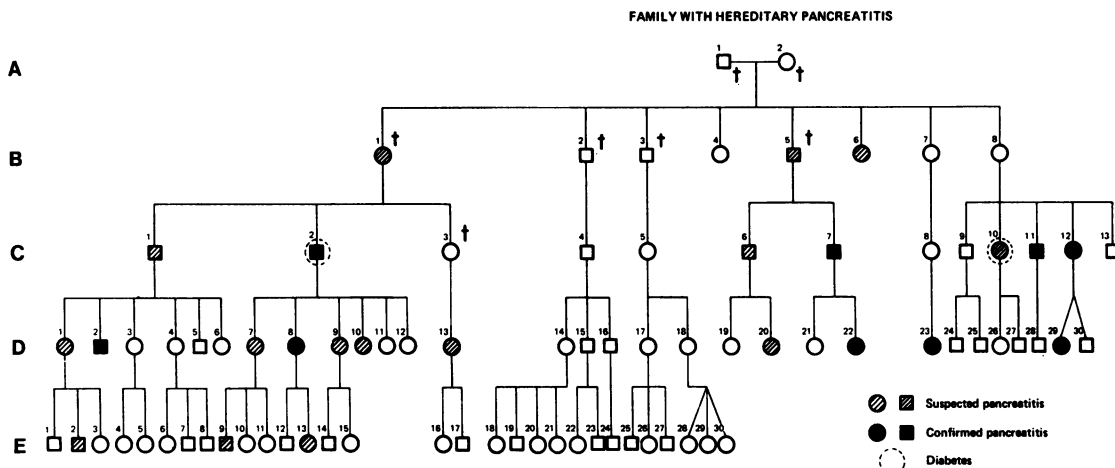

Fig The family tree of the series of cases described here

#### CASE C 1 (SON OF CASE B 1)

Aged 59 years now but started having attacks of severe abdominal pain when aged 16. These lasted three to four days, were associated with vomiting, and were usually epigastric. He was invalided out of the Royal Navy with them in 1941 (when aged 26 years) although no diagnosis was made. At their worst the attacks occurred every three months. They stopped when he was aged 40 years and have not recurred since. There is no abdominal calcification on straight radiographs of the abdomen.

The children of case C 1 live in Western Australia.

#### CASE D 1 (AGED 31 YEARS)

Occasional attacks of epigastric pain lasting three days approximately. They were never severe and started when she was a teenager and have got better recently.

#### CASE E 2 (SON OF D 1)

Boy aged 10½ years. Has had three attacks of abdominal pain, one of which required admission to Princess Margaret's Hospital in Perth. However, it cleared up before any diagnosis could be made.

#### CASE D 2 (AGED 29 YEARS)

Started having attacks of acute epigastric pain when aged 20 years. He was referred to the Royal Perth Hospital, Western Australia, from a distant hospital. During an attack of pain a barium meal had shown a space-occupying lesion in the head of the pancreas, distending the duodenal loop. Serum amylase was 1000 Somogyi units/100 ml, and a diagnosis of acute pancreatitis was made. After initial conservative therapy, laparotomy was performed which showed an 'abscess at the head of the

pancreas'. The postoperative course was complicated by deep vein thrombosis in the legs and a bilateral pleural effusion.

Over the next year he was admitted four times with episodes of acute abdominal pain, diagnosed as relapsing pancreatitis. Initially some of these were diagnosed as being hysterical; however, a raised serum amylase concentration was found during all of them. In July 1966, a year after his initial admission he had a further attack and after this sphincterotomy was performed. At operation the pancreatic duct was intubated and found to be patent. A probe passed easily through the sphincter of Oddi and sphincterotomy was performed.

He was twice admitted to hospital in 1967, once in 1968, three times in 1969, twice in 1970, and once in 1971, each time with acute abdominal pain. One of these attacks was precipitated by having three pints of beer on New Year's Eve of 1967. He had an unexplained episode of rectal bleeding requiring a blood transfusion in 1971, but has not had further recurrences of pain since 1971.

#### CASE C 2

Now aged 57 years, he lives in Birmingham. He was investigated for recurrent abdominal pain and vomiting at the Queen Elizabeth Hospital in 1953. A barium meal was normal. In 1957 he was admitted to the Dudley Road Hospital, Birmingham, with an attack of acute abdominal pain which was thought by his referring general practitioner to be a perforated duodenal ulcer. This view was shared by the admitting house officer; however, the pain improved and he did not have a laparotomy. A cholecystogram in the convalescent period was normal. Two months after the episode he developed polyuria

and polydipsia. Diabetes mellitus was diagnosed and he is controlled on a diet and oral agents. There has been no recurrence of the abdominal pain since 1958. However in 1968, he had an episode of loin pain and haematuria after which he passed a stone perurethram. An intravenous pyelogram taken after this episode showed normal kidneys and calcification in the pancreatic area.

Case C 2 had six daughters.

**CASE D 7 (AGED 31)**

Started having attacks of abdominal pain and vomiting when she was about 10 years old. The pain was situated in the epigastrium, left hypochondrium, and lower chest, and an attack lasted a few days. Initially she had attacks twice a year with only two attacks in the last five years.

When she was 13 years old she had what was probably rheumatic fever with  $\beta$ -haemolytic streptococci in the throat, a rash, and systolic murmur.

**CASE E 9**

The son of case D 7, who is now 12 years old, has had several episodes of epigastric pain and vomiting, lasting one to two days, not requiring admission to hospital.

**CASE D 8**

Now aged 29 years has had a similar history to her older sister of episodes of abdominal pain going back to her teenage years. She was admitted to hospital when aged 22 years with an attack of recurrent abdominal pain which radiated from the epigastrium to the back. There was no guarding or gross abdominal tenderness. Investigations showed a normal barium meal and cholecystogram. The serum amylase concentration was raised at 280 Somogyi units/100 ml (laboratory's normal up to 180 unit/100 ml); however, this was not thought to be significant and the pain was judged to be hysterical. She was admitted two months later to another hospital with similar pain and again a raised serum amylase concentration was found. At laparotomy the pancreas was not examined. She has had several attacks of mild epigastric pain since this episode.

**CASE E 13**

Now aged 7 years, was admitted to the East Birmingham Hospital when aged 6 years with severe abdominal pain and vomiting. One of the vomits was bloodstained. An intravenous pyelogram and barium meal were normal. She has had similar attacks of pain since.

**CASE D 9 AND D 10**

These sisters have had similar attacks of abdominal pain and vomiting to their older sisters since their teens. Case D 10 describes the pain as being severe and disabling.

**CASE C 3**

Died aged 32 years of carcinoma of breast. Never had abdominal pain. Her daughter, Case D 13 (now aged 28 years), lives in Italy and is married to an American. She very occasionally had some abdominal pain during her twenties, particularly after the births of her children.

**CASE B 2**

Died aged 45 years after an accident at work. His descendants have no history of abdominal pain.

**CASE B 3**

Died aged 72 years of a cerebral thrombosis. His daughter, case C 5, died age 50 years of bronchopneumonia. Her pancreas was normal at necropsy and her children and grandchildren have had no abdominal pain.

**CASE B 4 (AGED 69 YEARS)**

Lives in Colwyn Bay and has had no history of abdominal pain.

**CASE B 5**

Died aged 71 years from a cerebral thrombosis. He is remembered by his sons as having attacks of abdominal pain which are said to have started in childhood. They ceased when he was aged approximately 50 years. He had two sons.

**CASE C 6**

Now aged 50 years (lives in Bishop Auckland), he started having abdominal pain when aged 7 years (epigastric pain radiating to the back) lasting two to three days, two to three times per year. They were often associated with vomiting. They caused him maximum trouble when he was in the army during his twenties. No diagnosis has ever been made. He is a long distance lorry driver and in 1971 was admitted to a hospital distant from his home with acute abdominal pain. It was thought initially to have been due to a perforated ulcer but the pain gradually resolved, and no laparotomy or serum amylase estimation was undertaken.

His daughter (case D 20), now aged 21 years, was admitted to the Royal Victoria Infirmary in Newcastle when aged 2½ years with abdominal pain and severe gastrointestinal bleeding which required transfusion. No cause was found on investigation (including a barium meal) and

it settled after two days. She had several episodes of abdominal pain (lasting three to four days) during childhood.

#### CASE C 7

Now aged 37 years, started having abdominal pains and vomiting at 5 years of age. He had approximately three to four attacks per year between the ages of 5 and 21 years. Attacks lasted up to two weeks. He was admitted to the Fleming Hospital in Newcastle when age 9 years but notes have been destroyed and no diagnosis was made. In 1961 he had a negative laparotomy at the Edgware General Hospital, and in 1962 an episode of melaena for which no cause could be found. In 1963 he had an episode of acute abdominal pain during which a marginally raised amylase concentration was found. In 1964 at Bishop Auckland General Hospital he had an episode of severe abdominal pain during which the diagnosis of acute pancreatitis was made with a serum amylase of 2500 Somogyi units/100 ml. Since then he has had several minor attacks of pain, but has been free of pain for the last five years.

#### CASE D 22

Daughter of case C 7. Now aged 11 years, has had intermittent attacks of acute abdominal pain since she was 5 years old. These are epigastric and usually last three to four days. They had been investigated at the Hartlepool General Hospital, with negative results. However, a mildly raised serum amylase concentration was found by her general practitioner during a recent attack. She has at least four attacks every year.

#### CASE B 6

Now aged 70 years. Apparently had attacks of abdominal pain when a child and a young adult but her memory of them is rather vague.

#### CASE B 7

Case B 7 and her daughter case C 8 have no history of abdominal pain. However, case D 23 (daughter of case C 8), now aged 15 years, has had a history of intermittent abdominal pain since the age of 5 years. This had become more severe a year before she was admitted to the hospital in Coventry, with acute abdominal pain in 1971. Investigations, including a barium meal and an intravenous pyelogram (but not a serum amylase estimation) were negative.

She was again admitted in March 1972 with acute abdominal pain, and a laparotomy showed some nodularity of the pancreas. An operative cholangiogram was normal. In February 1973, during a further episode of abdominal pain, the serum amylase

concentration was 2250 Somogyi units/100 ml.

#### CASE C 8

Always free of pain. No calcification was seen on straight radiographs of the abdomen. She has five children.

#### CASE C 9

Now aged 37 years, he had some epigastric pain before meals during a period of stress when he was in his late twenties. However, the pattern of this pain was not really similar to attacks of pancreatic pain in the rest of the family.

#### CASE C 10

Maternal aunt of case D 29, born in 1939, started having attacks of abdominal pain radiating to the back at the age of 4 years. These were often associated with vomiting and are remembered as being severe. She had two to three attacks per year. In 1947 she had an appendectomy elsewhere for which no records are available. In 1948, aged 9 years, she was admitted to the Royal Victoria Infirmary, Newcastle, with abdominal pain. This was recorded as being central; however, no abnormality was noted on examination apart from a slightly raised temperature. Investigations showed a white blood count of 11 000 per cmm, a positive Mantoux test, and an old healed primary complex on chest radiographs. Urine was normal on microscopy. The pain subsided after five days and she was discharged. She was admitted again in March and September of 1949 with similar pain. Nothing was found on examination and an intravenous pyelogram, blood urea, and a barium meal were normal. Repeat urine examinations were negative.

Her attacks lessened after this, and since the age of 18 years she has had only two severe attacks when aged 29 and 31 years, though she has had several minor ones. She developed diabetes mellitus when aged 26 years and is now on lente insulin (32 units/day). She has two children aged 4 years and 1 year who are well and without abdominal pain.

#### CASE C 11

Maternal uncle of case D 29 was born in 1944 and was well until aged 17 years. He then started having attacks of severe abdominal pain every two to three months. These lasted between two and five days and were associated with vomiting. The pain was epigastric, constant, and radiated to the back. His alcohol consumption was no more than 3 to 4 pints of beer per week. When he was aged 19 years, he was seen by a physician as an outpatient and a provisional diagnosis of peptic ulceration was made, although a barium meal was normal.

In May 1964, when he was aged 20 years, he was admitted to hospital with an attack of similar severe pain and vomiting. On examination he had generalized abdominal rebound tenderness and guarding, worse in the epigastric region. Serum amylase was 1600 Somogyi units/100 ml. At laparotomy the pancreas was found to be hard, inflamed, and grossly nodular, with a considerable amount of intralobular oedema. The pancreatic duct was not noted to be abnormal. Cholecystectomy and left splanchnicectomy were performed. The postoperative course was complicated by a left basal pneumonia and a pleural effusion; however, this cleared on treatment, and he was discharged 19 days after admission.

Since then he has averaged two to three attacks of abdominal pain per year, only one severe enough to require admission to hospital in August 1970. Serum amylase was 560 Somogyi units and calcium 9.2 mg/100 ml. Blood sugar was 88 mg/100 ml. He had one attack at Christmas 1971 associated with a mild alcoholic excess. His stools are normal in appearance. His son is free of pain.

#### CASE C 12

Mother of case D 29, aged 25 years, started having attacks of abdominal pain at the age of 16 years. Since then she has had attacks of pain approximately every six months. The pain radiates to the middle of the back, and attacks last from three to five days. She usually vomits with the pain. The attacks of pain have never been severe enough to require admission to hospital, though they have been moderately disabling. There is no dysuria or bowel disturbance. The attacks of pain had been diagnosed as pyelitis. An intravenous pyelogram was normal, with no pancreatic calcification. During an attack in November 1972, a serum amylase concentration of 400 Somogyi units/100 ml was found. Urinary aminoacids were normal.

#### CASE D 29

A girl aged 5 years at presentation (May 1972) had been previously well. She had a 36-hour history of constant central abdominal pain and had vomited four times. There were no bowel or urinary symptoms. On examination she was afebrile, had mild central and upper abdominal tenderness without rebound tenderness or guarding. The remainder of the physical examination and urine analysis were negative. It was thought that there was insufficient indication for laparotomy at this stage; however, next morning the abdominal pain had become more severe. On examination there was generalized guarding and severe tenderness over the whole abdomen. Laparotomy was performed with a pre-

operative diagnosis of peritonitis. This was performed through a lower right paramedian incision, and showed clear free fluid with a normal appendix and small bowel. The pancreas was thickened and inflamed with considerable induration near the spleen. Though she had a considerable amount of abdominal pain for four days after operation, she made a good recovery and was discharged, free of pain, nine days after admission. The serum amylase concentration 24 hours after operation was 320 Somogyi units/100 ml. She previously had clinical mumps when aged 3 and her mumps V titre was 1/40. This had not risen two months later. Serum calcium was 9.1 mg/100 ml. There was no glycosuria and a random blood sugar estimation was 130 mg/100 ml. A urinary amino acid chromatogram showed an excess of taurine with other amino acids at normal levels. Lipoprotein electrophoresis was normal.

Five weeks after her original presentation she again had severe abdominal pain and vomiting. She had upper abdominal tenderness with variable guarding, but was not shocked or dehydrated. Serum amylase was 1600 Somogyi units/100 ml. A diagnosis of recurrent pancreatitis was made, and she was treated with analgesics (pethidine) or oral fluids. The pain resolved over four days.

She had a further attack of pain in December 1973, which lasted five days. A raised serum amylase concentration was found. Sweat sodium was 45 m-equiv/l.

#### Discussion

The pattern of inheritance of the disease in this family fits in well with an autosomal dominant inheritance with incomplete penetrance. Of the eight children of cases A 1 and A 2, five appear to have the pancreatitis gene (B 1, B 5, B 6, B 7, and B 8). Of particular interest are cases B 7 and B 8, both elderly ladies with a good memory. They are definite that they had no abdominal pain in childhood or as young adults, yet they passed the pancreatitis gene to their children and grandchildren. Moreover the severity of disease in a parent is no indication of the severity in the child. Case C 12 has only mild disease with a very occasional attack of pain starting at the age of 15, yet D 29, her daughter, has had severe pain starting from the age of 5 years. The pattern of inheritance is very similar to the large kindreds previously described in America by Gross *et al* (1962b), Kattwinkel *et al* (1973), and McElroy and Christiansen (1972).

The pattern of illness in patients in this family appears to be episodes of acute and severe upper abdominal pain lasting two to seven days and not

occurring more than three or four times a year and often less. The pain is most usually described as being epigastric but often radiates to the back and loins. It is sometimes central, and shoulder tip pain sometimes occurs (case D 2). Vomiting is common and sometimes leads to dehydration. The attacks start in childhood or in the teenage years. The mean age of onset in this family is 12.5 years. The youngest definite age of onset is 5 years (case D 29 and case D 23). The mean age of onset in the families described by Kattwinkel *et al* is 5 years, 16 years, and 15 years respectively. The attacks of pain vary from a severe illness (cases D 2 and D 23) to attacks of mild discomfort. Individual members can experience severe and mild attacks. Admission to hospital is not commonly required. Usually attacks appear to have no precipitating cause but occasionally they are precipitated by alcohol (cases D 2 and C 11), or by lack of food, either from poverty (case C 1 in the years of the depression) or by dieting (case D 10). Essentially then the pattern of disease in this family seems to be relapsing chronic pancreatitis.

The diagnosis in the nine definitely diagnosed cases was made by laparotomy in four cases, by raised serum amylase concentrations in four cases, and by abdominal pancreatic calcification on radiographs in one case (case C 2). Several members have been thought to have had hysterical abdominal pain (cases C 1, C 8, D 2, D 6, and D 7), but later have had pancreatitis confirmed.

A feature in this family is that the attacks of abdominal pain appear to cease when the patients are 30 to 40 years old. Cases C 1 and C 2 have had no attacks since they were 40 years old and case C 7 since he was 31 years old. Case C 5 is said not to have had attacks since he was 50 years, and the frequency of attacks of pain in cases C 6 and C 10 have lessened considerably since they were 25 years. This feature has not been commented on in previous reports on this subject; however, on reading the individual case histories, it is probably present in many other families.

Another feature, which may in fact, be only coincidental, is that three patients (cases D 2, D 7, and D 20) have had unexplained episodes of severe abdominal bleeding requiring blood transfusion but clearing up spontaneously without laparotomy. Barium meals in all three cases were negative. McElroy and Christiansen (1972) reported a family with pancreatitis and portal vein thrombosis who suffered gastrointestinal bleeding. Apart from this family the feature has not previously been described.

Two members of the family described have diabetes mellitus (C 2 and C 10). Case C 2 is on oral hypoglycaemic agents. Case C 10 is on lente insulin; there is, however, a strong history of diabetes

on her father's side of the family (her mother has the pancreatitis gene). Moreover diabetes mellitus presented at a period of her life when she was relatively free of pain, and there is no evidence of malabsorption. Diabetes mellitus occurred in nine out of 32 patients with familial pancreatitis described by Gross *et al* (1962b) and in 25 of 81 patients in Kattwinkel's series. It is likely that in the family reported here the incidence of diabetes mellitus is not significantly greater than in the general population. This view was also taken by Kattwinkel *et al* (1973) reviewing the patients in their series. Pancreatic carcinoma has been reported to have an increased incidence in various kindreds (eight cases in the literature) but only one patient in this family (case B 1) died of abdominal carcinoma. This was of the descending colon.

One patient (case C 2) has had pancreatic calcification in this family. It seems commoner in the families in America, occurring in 17 out of 38 patients in the series of Gross *et al* (1962b), and in 17 out of 81 of Kattwinkel's (1973) series. A family was described by Carey and Fitzgerald (1968) with hyperparathyroidism and familial pancreatitis, but all the calcium serum values which have been measured in the present family were normal (cases D 2, C 1, D 8, C 7, C 11, and D 29).

The original families described by Gross had a lysine-cystine aminoaciduria but many families have been reported since then without this feature (see table). They do not seem to be significantly different in any other way. Kattwinkel *et al* (1973) considered that the lysine-cystine aminoaciduria was coincidental, and due to an unrelated cystinuria in these families. In this family urinary amino acid findings show a slight excess of taurine (probably not significant) in case D 29 and 28, with other patients investigated (C 10, C 11, C 12, C 6, C 7, and D 22) being normal. There are 14 females and 10 males in the present series, and there has not been a significant preponderance of either sex in any of the previously reported series.

The previously reported families in the British, American, and French literature are set out in the table.

Pancreatitis, and especially chronic pancreatitis, has been thought to be an uncommon condition in childhood. It has almost certainly been underdiagnosed. Hendren, Greep, and Patton (1965) describe 15 cases. There have been nine cases in the Newcastle Regional Board area since 1967 (Sibert, 1975). Recognized causes includes mumps virus infection, type I hyperlipoproteinaemia, hereditary hyperparathyroidism, and trauma. These conditions have been excluded in this family. Hereditary pancreatitis is probably the most common cause



- Gross, J. B., and Comfort, M. W. (1957). Hereditary pancreatitis: report on two additional families. *Gastroenterology*, **32**, 829-854.
- Gross, J. B., Gambill, E. E., and Ulrich, J. A. (1962a). Hereditary pancreatitis: description of a fifth kindred and summary of clinical features. *Amer. J. Med.*, **33**, 358-364.
- Gross, J. B., Ulrich, J. A., and Maher, F. T. (1962b). Further observations on the hereditary form of pancreatitis. In *The Exocrine Pancreas, Normal and Abnormal Functions: CIBA Foundation Symposium*, edited by A. V. S. DeReuck and M. P. Cameron, pp. 278-309. Churchill, London.
- Hendren, W. H., Greep, J. M., and Patton, A. S. (1965). Pancreatitis in childhood: experience with fifteen cases. *Arch. Dis. Childh.*, **40**, 132-145.
- Kattwinkel, J., Lapey, A., di Sant 'Agnese, P. A., and Edwards, W. A. (1973). Hereditary pancreatitis: three new kindreds and a critical review of the literature. *Pediatrics*, **51**, 55-69.
- Logan, A., Jr., Schlicke, C. P., and Manning, G. B. (1968). Familial pancreatitis. *Amer. J. Surg.*, **115**, 112-117.
- McElroy, R., and Christiansen, P. A. (1972). Hereditary pancreatitis in a kinship with portal vein thrombosis. *Amer. J. Med.*, **52**, 228-241.
- Nash, F. W. (1971). Familial calcific pancreatitis: an acute episode with massive pleural effusion. *Proc. roy. Soc. Med.*, **64**, 17-18.
- Robeck, P. J. (1967). Hereditary chronic relapsing pancreatitis: a clue to pancreatitis in general? *Amer. J. Surg.*, **113**, 819-824.
- Sibert, J. R. (1973). Hereditary pancreatitis in a Newcastle family. *Arch. Dis. Childh.*, **48**, 618-621.
- Sibert, J. R. (1975). Pancreatitis in childhood: a study in the north of England. *Arch. Dis. Childh.*, in press.
- Whitten, D. M., Feingold, M., and Eisenklam, E. J. (1968). Hereditary pancreatitis. *Amer. J. Dis. Childh.*, **116**, 426-428.