

THE HEAT PRODUCTION OF FATIGUE AND ITS
RELATION TO THE PRODUCTION OF LACTIC
ACID IN AMPHIBIAN MUSCLE. BY RUDOLPH
A. PETERS, *Benn Levy Student and Student of Gonville and
Caius College.*

(*From the Physiological Laboratory, Cambridge.*)

Introduction. The belief that the contraction of a muscle is due primarily to the liberation of lactic acid from some precursor at or near some surface in the fibril, so as to cause a rise of tension in the muscle has gained support from several recent investigations. That the shortening of muscle in fatigue and rigor is due to the action of metabolic products, chiefly of lactic acid, has been a view in existence from the time of Ranke¹; and it has been suggested by Gad² that the normal contraction has a similar causation. It has been brought into prominence again owing to the work of Fletcher and Hopkins³. In their work they showed that fatigue was associated with a marked increase of lactic acid, and that the process culminating in the stiffening of rigor was accompanied by a certain maximum production of acid. Again A. V. Hill⁴ has argued from the production of heat and its relation to the time of the mechanical response that the contraction probably takes place in this manner. Considering the summation of contractions, Mines⁵ has pointed out that a sudden liberation of acid might certainly be the cause of the electric change, which he shows⁶ for his combined curves of the electrical and mechanical response in the excised frog's heart to occur before the mechanical response. That acid liberated upon the surface of some colloidal structures will produce a shortening is known from the work of Fischer and Strietman⁷. Acid rigor has

¹ Ranke. *Grundzüge der Phys.* p. 632.

² Gad. *Arch. f. Phys.* p. 166. 1893.

³ Fletcher and Hopkins. *This Journal*, xxxv. p. 247. 1907.

⁴ A. V. Hill. *Ibid.* xlvi. p. 28. 1913.

⁵ Mines. *Ibid.* xlvi. p. 1. 1913.

⁶ Mines. *Ibid.* xlvi. p. 188.

⁷ Fischer and Strietman. *Koll. Zeit.* x. 1912.

long been known and Fletcher¹ has given curves showing the shortening of a muscle in lactic acid.

Upon *a priori* grounds, it might be supposed that the liberation of a quantity of lactic acid sufficiently large to cause the rise of tension observed in a muscle would be attended by some thermal change as well as by an electrical one. It has been long known that a thermal change existed in contraction, and A. V. Hill² has estimated the heat evolved under the same conditions as the lactic acid production observed by Fletcher and Hopkins.

Hill shows that the heat produced during the survival life of amphibian muscle follows approximately the curves of CO₂ and of lactic acid production. All conditions which affect the liberation of lactic acid seem to affect the evolution of heat in a similar sense, there being for heat the same attainment of a maximum in heat and chloroform rigor as for lactic acid.

In one case, however, Hill did not study the simultaneous production of heat and lactic acid, the production of heat during the fatigue induced by artificial stimulation. It is known from the work of Fletcher and Hopkins that acid is formed when fatigue is induced in this manner. After severe and prolonged stimulation, they obtained a yield of about half the amount of acid to be obtained in complete rigor, either by heat or chloroform, being the same approximately for both. This was obtained usually by direct stimulation; in one case where indirect was employed, a similar result was obtained. Fatigue was shown by Hill to reduce the heat production of chloroform rigor in the same sense that it was reduced by periods of survival life. This reduction seemed to give further grounds for believing that rigor was an extended form of the process of contraction, that in both cases there was the liberation of chemical bodies, with the difference that in rigor the liberation (or breakdown) went further. Such a view has been held by Nysten (1811), by Schiff³ and by Hermann⁴. By a better method Fletcher⁵ confirmed the latter's demonstration that the CO₂ yielded in heat rigor was diminished by previous fatigue with the circulation intact,—*i.e.* that the processes of rigor and contraction made calls upon the same precursor.

If the processes which are the immediate cause of contraction are

¹ Fletcher. *This Journal*, xxiii, p. 54. 1898.

² A. V. Hill. *Ibid.* xlv, p. 466. 1912.

³ Schiff. *Beitr. z. Physiol.* II, p. 9. 1894.

⁴ Hermann. *Stoffwechsel der Muskel.* 1867.

⁵ Fletcher. *This Journal*, xxiii, p. 10. 1898.

the same as those which lead ultimately to rigor it is not unreasonable to suppose that the amount of heat liberated during a given degree of fatigue should bear to the heat production of chloroform rigor, the same relation as the lactic acid produced during a similar period bears to the total acid maximum. For if the processes of contraction involved other reactions (such *e.g.* as oxidations) than those culminating in rigor, the heat production of contraction might be incomparably larger in proportion.

Therefore it seemed that an opportunity was given of testing the hypothesis outlined above, as well as establishing any relation that might exist between heat production and the appearance of lactic acid. For if the heat production of chloroform rigor in the fresh muscle was roughly equal to the heat produced during stimulation plus the heat production of chloroform rigor after stimulation, it would not be necessary to assume that any process had occurred during stimulation other than that which had occurred in the process leading to rigor. (Any other change that might occur would necessarily be one taking place with small evolution or absorption of heat, and therefore probably of comparatively small importance.) If on the other hand the heat produced during prolonged contraction plus the heat production of chloroform rigor after contraction was much greater or much less than the heat production of chloroform rigor in the fresh muscle, another exothermic or endothermic process would be occurring during the contraction, and the hypothesis would need modification.

In this paper the question has been investigated from the standpoint of the following main questions.

(1) Was the maximum heat production of fatigue definitely greater than the heat production of chloroform rigor in the fresh muscle?

(2) If not, was the maximum heat liberated during contraction plus that liberated during chloroform rigor after fatigue approximately equal to the heat production of chloroform rigor in the fresh muscle, and what effect did the previous saturation of the tissue with oxygen have upon this equality?

(3) Further was the relation between the maximum heat production of a muscle contracting to a condition of fatigue and that of chloroform rigor in the fresh muscle of the same order as that between the amounts of lactic acid liberated under similar circumstances? If so, there would be further grounds for believing in an extremely intimate connection between the lactic acid appearing in a muscle and the evolution of heat.

Experimental method.

The older methods of observing the rise of temperature in a muscle during tetanus, which were made by Helmholtz and others with single muscles upon thermopiles, were not applicable to these experiments. As it has been pointed out by A. V. Hill¹, the mathematical calculation of the various quantities necessary to obtain the amount of heat liberated by a small mass of muscle in a prolonged contraction is very complicated and the results of such a method cannot pretend to the degree of accuracy required. This was the method used in the main by former observers. The necessary measurements require the use of as large quantities of tissue as is practicable, and the collection of the heat in a calorimeter, to minimise errors introduced by heat loss during an experiment.

The method chosen for experiment was in the main that which has been elaborated by Hill² for measuring heat production of CHCl_3 rigor. The principle of this method is the balancing of two flasks against one another for temperature loss and the elimination differentially in this way of most of the errors due to heat loss. The remaining heat loss can be calculated by correction with a small constant. In practice Hill's method needed modification for the experiment, in order to admit of working upon smaller quantities of muscles than he used. The use of large quantities of limbs would have meant a delay in obtaining the observations from the time of pithing the frogs. At first one set of limbs were used, but afterwards four as one set was not found to give sufficiently accurate results. The muscles were stimulated inside the flasks, and the heat collected with the aid of a small quantity of Ringer. The rise of temperature was observed thermoelectrically by finding the difference in temperature between the two flasks as a current flowing between thermal junctions, one thermocouple being in each flask. The E.M.F. was read as galvanometer scale divisions.

Description of galvanometer. The galvanometer was one of Pye's "Economic" moving coil 8025 galvanometers, modified for these experiments so as to have especially low resistance and to be as light as possible. This instrument had a swing when short-circuited with the thermopile of 15-20 secs. For thermopile work, as it is well known, it is necessary to have a galvanometer of a resistance approximately equal to that of the thermocouple used. Under these conditions the highest sensitivity is secured. Also I have observed that in order to get

¹ This *Journal*, XLVI. p. 32. 1913.

² *Ibid.* XLIV. p. 466. 1912.

the maximum galvanometer deflection with the least creep it is necessary to use a thermopile of as low a resistance as possible. But if the resistance is too low, the wire used is of large area and so conducts heat easily. In this latter case an error will be introduced from (1) the conduction of heat to the outside along the thermocouple and (2) the conduction of heat from the hot end to the cold end of the thermopile. It is therefore found that the best results were secured as follows. The galvanometer had a resistance of approximately 30 ohms, and the thermopile of 15 ohms. In these experiments, a thermopile of copper-constantan copper was used.

Description of flasks used. In order to get a sufficient degree of accuracy of reading with the galvanometer, it was found best to have a reading on the galvanometer scale of about 70 divisions, representing the rise of temperature produced during stimulation. This could be obtained in either of two ways, (a) by increasing the number of junctions in the thermocouple or (b) by decreasing the amount of Ringer in which the muscles were immersed, and so collecting the heat in a smaller volume of water and getting a larger observed rise of temperature.

Method (a) was tried and abandoned, because it is difficult to get a satisfactory insulation of the junctions in the same flask from one another without increasing seriously the errors due to added heat capacity and added surface for conduction to the outside of the flask. Even if insulation is perfect, I find that the increase of resistance seems to introduce some source of error into the galvanometer reading owing to the setting up of extensive creeping. Therefore method (b) was employed.

The adoption of method (b) involved the reduction of the fluid in the flasks to a small bulk of from 20–30 c.c. in the first experiments and more in the later and more accurate (50 c.c.). With quantities such as 50 c.c. in large Dewar flasks the heat loss is relatively extremely large owing to the fact that the heat loss is dependent very largely upon the area of the walls. Thus a small amount of water will lose in a given time the same amount of heat as a larger amount, and therefore much more temperature. Consequently smaller flasks were used of about 120 c.c. capacity.

Several important precautions were taken to secure uniform conditions outside the two flasks. They were placed inside a wooden tub (see diagram, Fig. 1) and surrounded by a layer of kapok (a vegetable wool), a small layer of eiderdown being placed immediately outside the flasks themselves. The thermopile (*T*) was composed of one copper

constantan junction in each flask. One piece of constantan wire was passed from the bottom of one flask to the bottom of the other insulated in glass tubing; to each end of the constantan, copper wires were fused and passed from the flasks as leads (T') to the galvanometer. Insulation was carried out by enclosing the wires in fine glass tubes; the ends of these which dipped in the fluid were sealed by binding with fine indiarubber membrane. This method of enclosing in fine glass tubes gave the additional advantage that the thermo-junctions were kept rigidly in the bottom of the flasks. This was found to be extremely

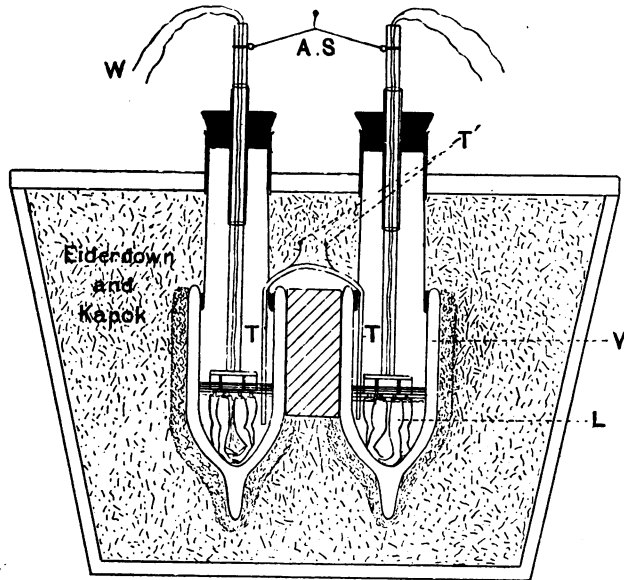

Fig. 1. Calorimeter used in experiments upon heat produced during stimulation. V =vacuum flask. T =thermopile with T' copper leads to galvanometer passing through eiderdown and kapok to the outside of the wooden tub. L =frog's limbs attached to stimulating apparatus for enlarged diagram of which see Figs. 2a and 2b. W =wires for stimulation, passing through fine glass rod to the ebonite disc to which the muscles are attached. $A.S.$ =apparatus for stirring automatically both glass rods, lifting them equal heights.

important when dealing with these small quantities of fluid in the bottom of the flasks, because if the thermo-junction were not covered, serious errors of reading were found to occur. The flasks were cemented together with a small piece of wood between them to prevent direct contact and the thermopile cemented into position in the flasks. In this way the apparatus was made stable. The copper leads from the ends of the thermopile were brought to the outside of the tub and

taken direct into the mercury of a Pohl commutator, which was connected with the galvanometer.

Cylinders of American cloth were then made which fitted exactly the mouths of the flasks, and these were cemented into the mouths of the flasks so that water poured inside the flasks could not leak into the interior of the tub. Holes were bored in the lid of the tub into which were fitted large pieces of glass tube of such a size that the cloth cylinders would just fit inside them; by sinking the flasks completely beneath the wool, it was arranged that the only place for conduction of heat to take place should be by the cloth cylinder. Corks were fitted to the glass tubes, which were bored and fitted with small glass tubes to take the glass rod to which the muscles were attached. In the construction of this apparatus I have to express my thanks to Dr C. G. L. Wolf for his kind help.

Apparatus for stimulating the muscles. In the first experiments before the foregoing apparatus was constructed, it was attempted to stimulate the muscles directly. This plan was abandoned, however, in favour of indirect stimulation; some justification for this abandonment was that Fletcher and Hopkins found that they obtained the same lactic acid yield whether the stimulation was direct through the muscles or indirect through the nerves; they performed however only one experiment upon this point. Indirect stimulation had the following great advantage that it was necessary to use only an extremely weak current, which produced a heat production of its own practically negligible.

The problem, then, narrowed itself into fitting 4-6 limb pairs into the flasks in such a way that the limbs were immersed in Ringer, were attached to a glass rod which should admit of stirring and through which could pass wires for stimulating the nerves. The whole had to be of as little heat capacity as possible and to present as little opportunity for the leakage of heat to or from the exterior according as the temperature of the room was above or below that of the interior of the flask. This was finally done as follows; for diagram see Fig. 2 *a* and 2 *b*.

A circle of ebonite of radius 33 mm. and depth 8 mm. was hollowed out in the centre so as to form a circular groove with the exception of a small boss, which was left and drilled centrally to hold exactly the glass rod containing the stimulating wires. In the narrow margin left round the edge were drilled six pairs of two holes at such a distance apart that they were fitted exactly to receive the two bones forming

the pelvic girdle of the frog's limbs. (This was found to be 7 mm.) Between each of these pairs of holes was cut a small slit extending into the circular trough 1 mm. deep and 1 mm. in cross section at the place where it entered the trough, being widened as it reached the outside and extended down between the two holes designed to hold the pelvic bones. A small horizontal groove was also cut in the boss in the centre. The finest glass tube obtainable was then fitted with the stimulating wires as follows.

A hole was blown in the side of the tube and a piece of platinum wire to which was attached fine copper wire (No. 38), fused into the side leaving as little prominence as possible. A similar wire was then

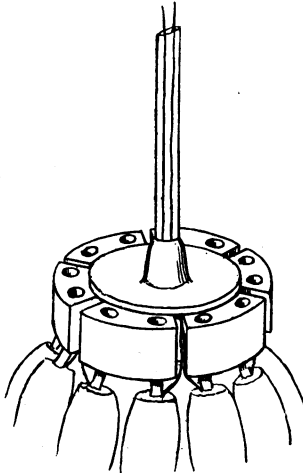

Fig. 2 a.

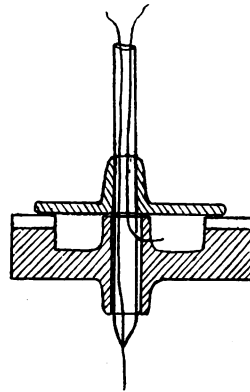

Fig. 2 b.

- Fig. 2 a. Enlarged view of ebonite discs with muscles attached. The nerves from the muscles are indicated passing through the 1 mm. square groove into the central trough. The glass rod down which the stimulating wires pass is also shown.
- Fig. 2 b. Sectional view of Fig. 2 a, showing positions of electrodes, one inside trough, and one passing through end of glass below the plate. The electrodes are platinum, and are fused into the glass tube.

fitted in the bottom of the tube, and the inside of the tube filled with paraffin for insulation before sealing. The hole in the ebonite plate was drilled to fit the glass exactly. The side electrode then was coiled inside the trough and the other below the ebonite. Lastly a plate of thin ebonite was arranged to fit closely upon the top of the trough so that the only passage of the current from inside to outside electrode was through the six holes all bored accurately to the same size.

Through these holes passed the nerves, the ends attached to the spinal column lying inside the trough. When the limbs were in position and the ebonite plate firmly fitting over the circular trough, the stimulating current passed from the platinum coil in the trough, through the holes containing the nerves, through the Ringer to the platinum coil below the ebonite disc. This is the principle employed by Lucas in stimulation, the stimulation being limited to the abrupt change of current density at the grooves through which the nerves passed. I am deeply indebted to Dr Lucas for help in the designing of this apparatus, and for cutting out the ebonite trough for me himself.

Apparatus for stirring. (Fig. 1, A. S.) In the earliest experiments the stirring apparatus was left uncontrolled, but this was found to produce an error of considerable size where such small quantities of heat were being observed. It was therefore necessary to control this, which was done by stirring two similar sets of muscles one set in each flask an equal amount. This was done quite simply as follows:—Two upright posts were fitted across the openings of the flasks which were arranged to hold a crossbar of brass upon which stood a small brass pulley. Over this pulley ran a cord attached to the excentric of a small motor, the end of the cord had a small hook attached to it, and this fitted over a small bent glass rod (V-shaped). The lower ends of the glass rod were attached to two hooks cemented to the upper part of the rods which held the muscles. By means of this apparatus, one stir of the motor or as many as were required could be made equally in each flask. The control for the stirring was tested several times, by giving 200 stirs and observing whether any change could be observed in the shape of the ordinary cooling curve. It was always found that there was no difference to be detected. In practice, 20 stirs were given between each set of readings. The additional advantage of the above apparatus was that it was never necessary to approach the calorimeter and to introduce irregularities due to radiation from the body.

Avoidance of thermoelectric errors in external circuits. These were made as simple as possible, and mainly of copper to avoid thermoelectric errors in the circuit. The copper leads from the thermopile were fused to thick copper wires, which passed straight to the mercury cups of a Pohl commutator, into which also were brought the galvanometer leads. Hence, the thermoelectric effects could be obtained except for the junctions in the flasks only at (1) the copper-mercury connections of the commutator; (2) the galvanometer terminals. The effects at (1) were minimised by arranging a bent glass rod to work the tip key of

the commutator from a distance. In the case of the galvanometer terminals, any accidental temperature difference was eliminated by taking the reading upon the scale as the difference between reversed deflections. In this way any constant E.M.F. beyond the commutator was eliminated.

Constant of heat loss. Determinations for the coefficient of heat loss by the method used by Hill of observing the time taken to cool through a certain number of degrees showed that the flasks were balanced for heat loss within 4%. But although the flasks were balanced for heat loss as regards the external temperature, a correction was needed for the difference in temperature between the flasks themselves. By Hill's method the heat loss appeared to be 25% of the difference between inside and outside per hour. Where this difference was substituted in the curves of H.P. observed, it appeared that the heat loss in the experiments could not be as great. Therefore the following method of direct calibration was used. Ringer's fluid was placed in the flask under the conditions and volume of the experiments, and the decrease of the deflection of the galvanometer (= decrease of temperature difference) observed over successive intervals. It was found that the decrease of the temperature difference in a given time (18 or 36 mins.) was remarkably constant.

Readings giving for k , 163, 158, 164, 155, 152, 159, 166, 159, 164, averaging $160 = 16.0\%$ of difference per hour.

k was calculated by reversing the ordinary calculation for heat loss. In the ordinary way the heat loss (H) over a given time (t) is calculated by multiplying the value of the middle ordinate (m) of that period by the constant k , *i.e.*

$$H = km \text{ in time } t \dots\dots\dots(1).$$

By the method H and m are known, so that it is necessary only to substitute in equation (1) to find k .

The average of the above values $k = 160$ was used in correcting the curves throughout the paper. It signifies that the flasks lose 16°C . of their temperature difference per hour. Reliance is placed upon this constant rather than any other, because it was obtained under the conditions of the experiments, and because it reduced the curves so well to a base line (see below).

The heat capacity of the flasks. Where such small quantities of water were being used in the flasks, it was difficult to get an accurate measurement of the heat capacity by mixing two volumes of water at known temperatures and observing the final temperature.

Accordingly the heat capacity was determined by liberating a known amount of heat inside the flasks and observing the rise of temperature

produced in a given volume of water as a deflection upon the galvanometer scale. This method proved to be useful also for checking the working of the apparatus. Heat was liberated by passing a known current for a known time through a coil of constantan wire of known resistance wrapped round a piece of vulcanite of the same size as that used for holding the muscles. To do this, the coil of wire was connected with a two volt accumulator, a key being placed in the circuit. The voltage was read from a sensitive voltmeter connected in parallel with the resistance.

The amount of heat liberated can be obtained from the following formula (Joule).

$$\text{Heat liberated (in coil in flask)} = \frac{E^2}{4 \cdot 18} \times \frac{R - r}{R^2} t,$$

where R = resistance of coil immersed in water + resistance of leads from accumulator, and r = resistance of leads from accumulator.

The coil used for the calibration had a resistance with the leads of 5.383 ohms, the leads having resistance 0.0233 ohm.

$$\text{Whence} \quad H = \frac{E^2}{4 \cdot 18} \times \frac{5 \cdot 360}{(5 \cdot 383)^2} t.$$

In a given case, $E = 1.981$ volts. Time = 179.8 secs.

$$\therefore H = \frac{(1.981)^2 \times 5 \cdot 360}{4 \cdot 18 \times (5 \cdot 383)^2} \times 179 \cdot 8 = 31 \cdot 2 \text{ calories.}$$

The galvanometer deflection in scale divisions = 144, corresponding to a rise of $\frac{144^\circ}{332}$ C. = 0.434° C.

Hence volume of water (60 c.c.) in flask + water equivalent of flask have been raised 0.434° C. by 312, i.e. 1° C. by $\frac{31 \cdot 2}{0.434} = 72$ cal.

Since 1 cal. raises 1 c.c. of water 1° C., eliminating 60 c.c. due to water in flask, we obtain

$$\text{Heat capacity} = 72 - 60 = 12 \text{ c.c. H}_2\text{O.}$$

By this means, for the heat capacity of flask were found the following values :

15, 11, 11, 17, 17. Av. 14.

18, 14, 12, 12, 12. Av. 13.6.

Average taken as 14 c.c.

The numbers are extremely variable, but the method is liable to considerable errors, owing to difficulty of reading the small voltage. Approximate accuracy only can be claimed for the average 14 c.c. A difference of 5 c.c. on either side would not make any serious difference in the calculated results.

Strength of current employed for stimulation and avoidance of the Wedensky effect. In the primary circuit of an ordinary induction coil were used two dry batteries giving three volts. The position of the secondary coil was roughly calibrated so as to give the approximate

current strengths for different positions or distances from the primary coil. At first the ordinary tetanising hammer was employed, but this was discarded later as it was found to have an extremely rapid rate of stimulation, causing the nerves to show a Wedensky effect when fatigued (Wedensky¹). Therefore for the later experiments an apparatus was used with a revolving brush contact by means of which the stimuli could be varied in frequency as desired from 6-40. In practice it was found that a rate of 14-16 per sec. gave the best results, that is to say tetanus without any possibility of the Wedensky effect. It was always possible to tell the presence or absence of this effect by the fact that the muscle gave a preliminary twitch at the instant of turning on the current, in the manner described by Adrian and Lucas.

Heat production of the current. As stated above, the method of indirect experiment was adopted after trying the direct, because the amount of current required to excite is relatively extremely small. The heat produced by the current was determined experimentally under the conditions of the experiments by passing the current for the same time as had been employed throughout the experiment and observing any increased rise of temperature in the flask. This was never found to be greater than from 1-2 scale divisions of the galvanometer.

Calibration of thermopile. The light was reflected from the galvanometer on to a fixed scale and the thermopile calibrated directly (in the same way that Hill calibrated his apparatus). That is to say a difference of temperature of about 1° C. was made between the flasks, determined carefully with an accurate Beckmann thermometer; the galvanometer deflection was then compared with this. The average of several determinations gave 1° C. = 332 scale divisions (individual determinations varied between 334 and 330). In the reading of the deflection, and in all the other galvanometer readings, the readings were the differences of the deflections obtained by reversing the current through the galvanometer. For instance if the galvanometer for a deflection right of the zero read 400, and left read 150, the reading taken would be $400 - 150 = 250$ scale divisions.

Experimental procedure. In all the experiments, other than those in Table I², the following method was employed.

¹ Wedensky. *Arch. f. d. ges. Physiol.* xxxvii. p. 69. 1885.

² In the earlier experiments (Table I) an apparatus was used, which was only applicable to one limb pair, therefore the method was much more liable to error. The results are given for comparison.

The limb pairs (eight in number) (four for each flask) were prepared for the experiment by skinning, dissecting out the sciatic plexuses of both sides with a small piece of spinal column leaving the pelvic bone attached to it and removing the attachments of muscles of the abdominal wall without injury to limb muscles. After the dissection of each limb, it was placed in order in a dish of Ringer. The two pelvic bones were fixed in the ebonite plate by threads. The nerves were then passed through the slots, and kept in position by the spinal column attached and lying in the central troughs (see Fig. 2*a*). The whole of this operation took about 25 minutes from the pithing of the first frog.

In order to balance the limbs against one another in respect of the resting heat production, observed by Hill to be relatively very large in the first hour of survival life, each alternate limb was taken together from the dish of Ringer, *i.e.*, 1, 3, 5, 7, and 2, 4, 6, 8, so that the muscles should be in as directly a comparable condition as possible. Let us call the sets of four limbs *A* and *B* respectively. *A* and *B* were weighed separately and the volume determined for each. The limbs were then placed in the flasks where they remained until they had been in for 20 mins. after which the first reading was taken. Observations were then taken at intervals of about 3–6 mins. until constant conditions were obtained (this was usual at the end of 20 mins.). The stimulus was then applied to the muscles of *A* (contraction was always signified by the raising of the glass rod in the flask). Another reading was then taken and this process continued until no further contraction was obtained through the nerve for stimuli 3–6 times the strength of the threshold for excitation. After contraction had ceased and there appeared to be no further H.P. upon stimulation, the current was passed for the total time of the experiments as a control of the heat produced by the current.

In order to obtain the values of the H.P. in terms of muscle tissue, and not limbs, the limbs were weighed before placing in the flasks to get the weight of bone + muscle in the resting condition. At the conclusion of the experiment the muscles were cut off as completely as possible and the bones weighed. The weight of muscle substance was given by the difference between the two weights. In order to get strictly comparable conditions, the muscles must be weighed before stimulation as the change of osmotic condition in the stimulated muscle would give a different result¹.

¹ *Vide Fletcher. This Journal, xxx. p. 414.*

Calculation of actual value of heat production. The temperature differences between the two flasks, obtained as galvanometer scale divisions, were plotted on squared paper as ordinates, the abscissæ representing intervals of time. They were corrected for heat loss by the method described by Hill¹, by multiplying the ordinate at the middle of a given period by the coefficient of heat loss and correcting the points upon the observed curve accordingly. It has been shown by Hill that the resting heat production is a comparatively large quantity, especially in the first few hours. In any calculation of heat produced during stimulation over long periods, this has to be taken into account.

The method as finally modified will be described. Figs. 3 and 4 are two of the actual curves of heat production obtained and chosen at random from the experiments given in Table II. The upper irregular curves are the observed curves of heat production. Periods of stimulation referred to approximate current strengths are marked in black patches. Before stimulating observations were continued for periods of 10–20 minutes in order to obtain a sufficiently even curve for continuation as a base line. The lower curve is drawn through the points of correction. The resting curve corrected for heat loss is continued as three black lines, of which the middle is drawn through the corrected points, the other two lines representing the approximate limits of the experimental error involved in the continuation of the base line. As the galvanometer cannot be read accurately to less than .5 of a scale division, the experimental error of any observation may be one division upon either side of the observed point: this is indicated in the diagram by a small rectangle. The error in time cannot be more than .5 of a minute. When stimulation ceases to cause a further heat evolution, the number of scale divisions between the position of the corrected curve for stimulation and the continuation of the line for the resting heat production is reckoned as the heat evolved in contraction of the muscle to a state of fatigue. A description of further points will be given under the experimental results.

Results of experiments.

In the earliest experiments, to be quoted in Table I, one frog's limb was used in each flask, that in the control flask being dead. The resting heat production was therefore very large, and observations had to be continued for a very long time, 30 minutes or more, in order to get even approximate accuracy in continuing a line drawn through them. The

¹ This *Journal*, XLIII, p. 274.

TABLE I. *Heat production in muscles, dead muscles being used as controls.*

Calories (gram) per c.c. limb skinned	Temperature C.	Calories (gram) per gm. muscle (weight)	Rate of stimulation
A 1 0.41	13	0.79	100-200 per sec.
A 2 0.63	14	1.08	" "
A 3 0.50	17	0.76	" "
A 4 0.22	16	0.36	" "
A 5 0.42	15	0.57	" "
A 6 0.42	15		
A 7 0.23	14		
A 8 0.20	11		
A 9 0.49	15		25 per sec.
A 10 0.50	17		30 "
A 11 0.70	19	1.05	14 "
A 12 0.44	19	0.60	13 "
A 13 0.31	14.5	0.57	50 "
Average 0.42 cal. per c.c.		Average .78	

errors involved in this method of control by a dead muscle were magnified by the steepness of the line of resting heat production, and are in all probability extremely large. It is considered to be worth while to record the results, as the average is certainly close to that obtained by the more accurate methods used for Table II.

The results are seen to be extremely variable, the wide variations may be due either to the conditions of the frogs (they were used at the breeding season) or to difficulties of observation. As far as they can be trusted, they seem to indicate a fact proved later that heat produced during periods of stimulation leading to fatigue is approximately half that produced in chloroform rigor upon the fresh muscle. For this, Hill found about 1.0 cal. per c.c., of which the value .42 cal. appeared to be nearly one half. This point however came out much more clearly in the later experiments.

In the experiments described in Table II, of which examples are given in Figs. 3 and 4, the difficulty connected with the resting heat production was minimised and practically removed in most cases, by using muscles in the control flask which had been treated in exactly the same manner as those prepared for stimulation. In this manner, it was possible approximately to balance the resting heat productions differentially against one another. Although it was practically never possible to obtain exactly similar pairs of limbs, the value of the method of control is certain, because of the near approach of the line for the resting heat production to the horizontal.

Figs. 3 and 4 representing Exps. 3 and 6, of which the full details are given below, illustrate the two extremes of balance obtained in the experiments of Table II. Fig. 3 is one of the best conditions of balance; Fig. 4 the worst. It is seen that in Fig. 4, the balance is quite close, being in fact closer than any of the curves of Table I. That the

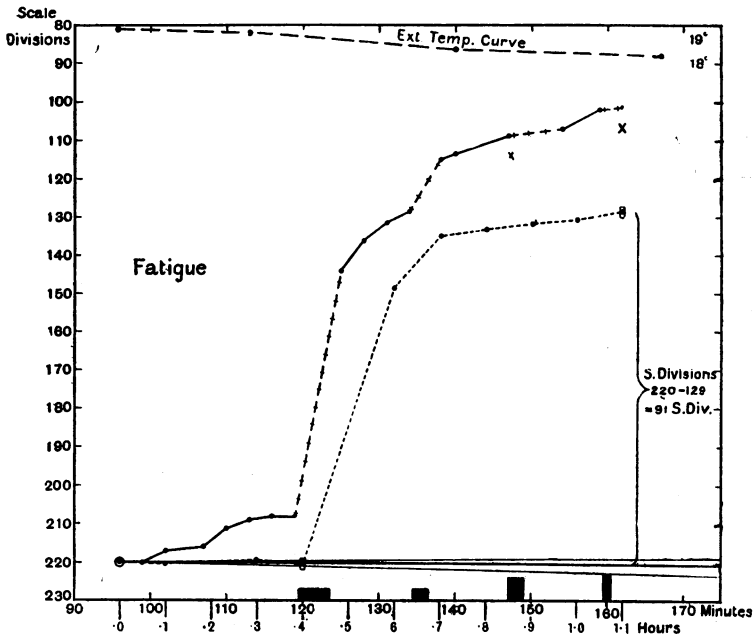

Fig. 3. Curve of heat evolution for stimulation to fatigue in Exp. 3, Table I.

Ordinates = scale divisions of galvanometer. Abscissæ = minutes from pithing, and decimal points of one hour from beginning of observation. Black rectangles represent times of stimulation with the approximate current strengths represented as ordinates.

Upper curve = observed curve of heat evolution.

Lower curve (dotted) = curve corrected for heat loss. The part of curve before stimulation is continued as a dark line, being the curve for resting heat production.

The rectangles round two observed points represent approximate experimental error of reading, the two lines on either side being drawn to obtain the experimental error of the observations of heat production. The bracket shows the number of scale divisions produced by stimulation. (External temperature curve shows variations in temperature conditions surrounding flasks during period of experiment.)

divergence of the line from the horizontal in Fig. 4 is not due to a bad correction for heat loss, is certain from the fact that the weight of the muscles used in the control flask was 3 grams heavier in this case, so that they would be expected to give a greater heat production and cause the direction of the corrected line found in Fig. 3.

In all the experiments 30 c.c. of Ringer were placed in each flask. The small differences caused by differences in volume amount of solution in the flasks were not large enough to make appreciable errors. Details of one experiment (Exp. 4) are given, the others were performed in a similar manner.

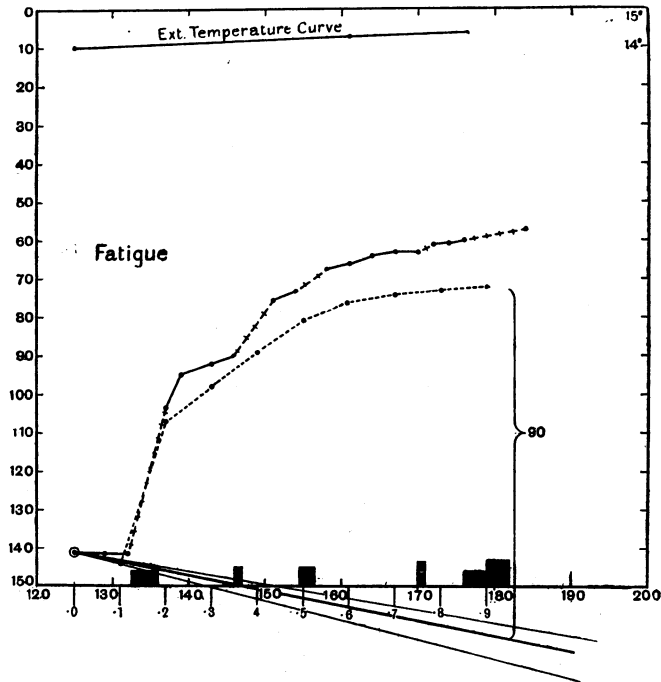

Fig. 4. *Fatigue Exp. 6.* For description refer to Fig. 3. The last stimulation period of 6 mins., 3 mins. at current strength 4, and 3 mins. at 8, represents control of heat produced by current.

TABLE II. *Heat production in muscles (April—May), living muscles being used as controls.*

1	2	3	4	5	6	7	8	9	10	11
Exp.	Limb weight, gms.	Muscle weight, gms.	Limb vol., c.c.	Stim. rate per sec.	Time of stim., mins.	H. P. stim., in Sc. Div.	No. of limbs used	Heat* per gm. musc.	Temp. °C.	Ext. temp. varied between
1	33.65	18.8	31	17	7	81	4	.93	16.9	16.9-17.5
2	31.0	18.8	28	38	7	55	4	.61	18.5	18.3-18.5
3	35.4	22.2	33.5	16	9	91	5	.91	18.7	18.8-19.2
4	33.4	21.2	31	8	8	67	4	.68	19.2	19.0
5	27.07	16.5	25	11	5	74	4	.90	17.4	16.8-17.2
6	33.05	20.5	30	14	8	90	4	.94	14	14-14.4
7	27.1	17.0	25	16	8	81	4	.92	17.8	17-18
8	27.7	16.6	(26)†	13	8	55.5	4	.67	14.5	14.1-14.7

* Heat production throughout this paper is measured in gram calories.

† Volume arrived at by averaging the others.

EXP. 3. (Fig. 3.) Limbs of frogs 1, 3, 5, 7 (A) used for stimulation flask. Limbs of frogs 2, 4, 6, 8 (B) for control.

Total weight of (A)	= 35.40 gms.	Total weight of (B)	= 33.40 gms.
Weight of bones only	= 13.20 ,,	Weight of bones only	= 12.90 ,,
Weight of muscle	= 22.20 ,,	Weight of muscle	= 20.50 ,,
Volume 33.5 c.c.		Volume 31 c.c.	

Time represents minutes from pithing of the first frog. Dissection took 20 minutes.

Time	Galvanometer reading	Time (contd.)	Galvanometer reading
96	220	131	131.5
99	220	134	128.5
102	217	Stimulation for 2 minutes at same.	
107	216	138	115.6
110	211	140	113.5
113	209	147	109
116	208	Stimulation for 2 minutes.	
119	208	154	107
Stimulation for 4 minutes.		156	102.5
Current strength 3.		159	102.5
Rate 100 revolutions in 50 secs.		Stimulation for 1 minute.	
= 800 stimulations in 50 secs.		162	101.5
= 16 per sec.		Control of heat production not done	
125	144	in this experiment.	
128	136.5		

Correction for heat loss. Constant $k = .160$.

Divisions of an hour represented on the curve for convenience as decimal points.

(Fig. 3.)

Period of an hour0-.1	.1-.3	.3-.4	.4-.6	.6-.7	.7-.8	.8-.9	.9-1.0	1.0-1.1
Value of ordinate m at middle of period	219	214	208	141	125	112.5	109	107.5	102.5
$(m \times k)$	3.51	6.85*	3.33	4.52*	2.0	1.80	1.75	1.72
$H \left\{ \begin{array}{l} m \times k + \text{total heat} \\ \text{loss} \end{array} \right\}$	3.51	10.36	13.69	18.21	20.21	22.01	23.76	25.48	27.12
Value of ordinate at end of period (e)	217	209	207	130.5	115	111	108	105	101.5
$e + H$	220.5	219.4	220.7	148.7	135.2	133.0	131.8	130.5

* = $2m \times k$.

Difference between curves of stimulation and resting heat production
= 91 scale divisions.

Approximate limits of error due to projection
= 88-94 scale divisions.

This error represents the divergence in the two thinner lines on either side of the line of resting heat production, being the projection of the small galvanometer reading error of 2% approximately.

Calculation of heat production¹.

1° C. = 332 scale divisions. Muscle weight = 35.4 gms., specific heat = 0.83, water equivalent of limbs = 29.4 c.c.

¹ Throughout this paper the specific heat of the tissue is taken to be 0.83, the approximate value given by Pembrey, *Schäfer's Text-Book of Physiol.* i. p. 839.

Temperature of flask and contents has been raised $\frac{91}{332}^{\circ}\text{C}$. Flask contains muscle (29.4 c.c.) + Ringer (vol. 30 c.c.) + heat capacity (14 c.c.) = 29.4 + 30 + 14 = 73.4.

Hence 22.2 gms. of muscle have evolved heat sufficient to raise 73.4 c.c. water $\frac{91}{332}^{\circ}\text{C}$.

Or, heat production per gm. of muscle during stimulation to fatigue

$$= \frac{91}{332} \times \frac{73.4}{22.20} \text{ calories} = .91 \text{ caloric.}$$

Approximate limits of error due to projection of curve of resting heat production
= .88-.94 calories.

The result given in column nine vary from .62-.94 calories per gram of muscle tissue, falling into two groups. This might seem to indicate the existence of two processes. But if two processes did exist, it is feared that the method may not be sufficiently accurate to decide between them, owing to the experimental error to which these results must be liable. The absolute experimental error is difficult to estimate as it depends upon (1) an error concerned with the projection of the small error of reading the galvanometer (about 2%) in the continuation of the line of resting heat production, amounting on the average to 10% of the total reading; (2) an error introduced by the inadvertent cutting of small nerve branches¹, and damaging of nerves in some cases at their attachment to the vertebral column in order to get the piece of bone sufficiently small to fit into the stimulation trough (Fig. 2*b*). This would produce a low value owing to the inclusion of unfatigued muscles in the calculation; (3) small errors in heat gain or heat loss in the calorimeter. Therefore taking into account errors (1) and (3) which might be in either direction, and the error (2) which must always be a low error, it is possible that the low results between .6-.7 are to be attributed to error (2)².

As the object was to discover the maximum heat production of stimulation to fatigue, the average of .93, .91, .90, .94, .92 = .92 caloric will be taken as representing the highest value obtainable in such periods of stimulation.

It will be remembered that the values for heat production of chloroform rigor obtained by Hill varied from .7-1.2 cal. per c.c. of frog's limbs, from which it certainly seemed the case that H.P. of

¹ In getting out the preparation, minute dissection was sacrificed to speed of manipulation.

² The experiments below in Table IV further make it probable that the low values represent want of fatigue of the muscles used. If two tone processes existed, it would be expected that the heat production of chloroform rigor after fatigue, obtained as it is by a more accurate method, would also show such division of results.

stimulation was not more than of the order of half of the total H.P. of rigor. In terms of c.c. the above value would reduce to about '6.

The next step then, was to determine the H.P. of CHCl_3 rigor in terms of grams of muscle substance.

This was done upon a large scale in two flasks (kindly lent me for the purpose by Mr Hill) which were exactly balanced as regards heat loss and in which owing to their size the coefficient of heat loss was extremely small. The limbs ten in number after a previous weighing were made up to the required volume (300 c.c.) with neutral Ringer, the whole operation being performed as quickly as possible. The limbs were removed without dissecting the nerves and the experiment was performed as described in Hill's paper with the exception that dead muscles were placed in the control flask. For stirring, the muscles lay upon a plate of ebonite to which was attached a glass rod passing through a hole in the cork of flask. To avoid any possible error due to heat of friction, both flasks were stirred equally.

Fig. 5 gives the curve of heat evolution obtained in Exp. 9. The heat loss was 1 scale division in this experiment. The chloroform was inserted at the point marked by an arrow, and after rapid stirring, the first reading taken. By a continuation of the curve backwards until it becomes parallel to the ordinate, the beginning of heat evolution, which takes place extremely rapidly, is taken as occurring at 20, the position being marked by a cross. The observed points are seen to fall extremely closely upon a curve.

Heat evolution in scale divisions extends from $-20 \rightarrow +68$,
 $\qquad\qquad\qquad = 88$ scale divisions,
 + 1 scale division heat loss = 89 scale divisions.

Heat capacity of flask = 20 c.c. $1^\circ \text{C.} = 327$ scale divisions.

Total volume of water + limbs + chloroform 10 c.c. = 300 c.c.

Water equivalent of limbs = 67.7.

Volume of limbs = 92 c.c.

Therefore heat production per gram of muscle substance

$$= \frac{89}{327} \times \frac{295.7}{47.46} = 1.694 \text{ cal.}$$

The results obtained corrected for heat loss, where necessary, were as follows:—

TABLE III.

Number of experiment	Limbs weight	Muscle weight	H. P. in scale div.	Heat per gm.	Temp. $^\circ\text{C.}$	Number of limb pairs used
9	80.64	47.46	84	1.69	15	10
10	98.20	58.36	105	1.70	13.5	10
11	77.18	44.88	80	1.70	13.5	10

The method of finding the heat production of chloroform rigor admits of an accuracy considerably greater than that of experiments in Table II, owing to the fact that the experiment is done upon a larger number of limbs, in a larger flask with a much smaller coefficient of heat loss; it is seen that the results for maximum heat production are remarkably constant and seem to have eliminated any error due to possible variability of tissue utilised.

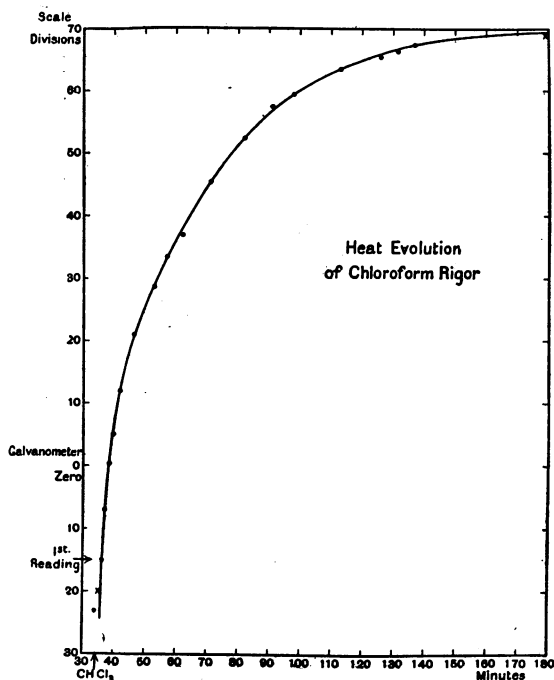

Fig. 5. *Exp. 9, Table III.* Heat evolution of chloroform rigor. Ordinates=scale divisions. Abscissæ=minutes. Arrow represents introduction of chloroform, and first reading. The two crosses mark beginning and end of heat evolution. The curve passes through the galvanometer zero, making calculation for heat loss unnecessary.

They average 1.70 cal. per gram. The close agreement of these three figures is probably fortuitous. Thus the heat production of stimulation to fatigue bears to the heat production of chloroform rigor in the fresh muscle roughly the same proportion as observed by Fletcher and Hopkins for lactic acid production, *i.e.* approximately one half.

It was shown by Hill that stimulation reduced the H.P. of CHCl_3 rigor very markedly. There were therefore grounds for thinking that the sum of the H.P. of stimulation and H.P. of rigor after stimulation

was not more than the total H.P. of CHCl_3 rigor in the fresh muscle. Experiments were done to determine the heat production of CHCl_3 rigor after prolonged stimulation. In all the experiments, given in Table IV, the limbs were stimulated as in the preceding experiments, for 5–10 minutes, at rate of 14–16 per sec.

TABLE IV. *Heat production of chloroform rigor for fatigued muscles.*

Exp. No.	Number of limbs	Limb weight	Muscle weight	H. P. (scale divs.)	Heat pr. per gm.	Temp. °C.
12	10	98·25	71·76	40	·86	18·5
13	10	78·3	31·7	33	·99	19
14	11	81·52	51·01	75	·91	17·5
15	9	49·20	28·93	37	·82	18
16	10	86·62	53·81	47	·80	17·5
17	9	95·96	60·88	70	1·04	17·5

In each of the experiments marked with an asterisk, it was observed that one of the large nerves going to one limb of one of the frogs was inadvertently cut. The result is on the high side, which is in accordance with expectation.

The gross variation of these values is $\cdot 80$ – $1\cdot 04$ calories per gram. The possible error is greater than in Table III, as there is only half the heat evolution, and less than in Table II, as the error (1) mentioned after Table II above does not occur. Cutting nerves would have the effect of giving an error upon the high side, which was observed in experiments 14 and 17. Exp. 13 was an earlier one, in which no special note was taken of possible nerve cutting.

An average of the values in Table IV excluding experiments 14 and 17, which are known to be invalid owing to nerve cutting, is $\cdot 87$ calorie per gram of muscle. From this it follows that the diminution of the value of chloroform rigor for the unstimulated muscle (Table III), if there be no other process involved in fatigue than in rigor, should be $1\cdot 70$ – $\cdot 87$ calories = $\cdot 83$ calorie. From Table II, the heat production of fatigue was shown to have a maximum value of $\cdot 92$ calorie per gram, a value sufficiently close to $\cdot 83$ calorie per gram to make it probable that the diminution observed in Table IV is a diminution of the heat producing process of Table III.

With regard to the lower values $\cdot 61$, $\cdot 68$, $\cdot 67$ calories in Table II, which it was considered could be explained by want of stimulation, in experiment 17, where a nerve was cut, $1\cdot 04$ calorie was obtained. $1\cdot 70$ – $1\cdot 04$ calories would be $\cdot 66$ calorie per gram. It is upon this ground that I feel that the low values are experimental.

If this be the case, the answer to the second question is that the maximum heat production of contraction plus the heat production of chloroform rigor in a similarly fatigued muscle is roughly equal to the heat production of chloroform rigor in the fresh muscle. For from Table II, we have for the maximum heat production of contraction .92 calorie per gram as an average, from Table IV for the heat production of chloroform rigor .87 calorie per gram as an average, of which the sum 1.79 calories is within experimental error of 1.70 calories, the value from Table III for the chloroform rigor of the fresh muscle. So it would seem that any other change beyond that occurring simultaneously with lactic acid liberation must involve only small heat changes¹.

In other words it would appear from these results that the processes of contraction and those of rigor do make calls upon the same precursor.

The next question was, whether the presence of a large amount of oxygen would upset the relation established above. The experiments were made in two ways :

In one the maximum heat production of fatigue was estimated and the muscle transferred to a high pressure of oxygen² for a time and then a further estimation made. Slight evidence of a further heat evolution of about .2 calorie was obtained in a few experiments, but the method of indirect stimulation was not found applicable owing to the difficulty of keeping up the effect of the nerves in the muscle.

In the other method, the muscles were placed in the Ringer's fluid previously saturated with oxygen, under pressure, and oxygen was bubbled through the fluid for a time,—depending upon the continuance of the effect of the nerve in the muscle, the maximum being 1½ hours,—the muscles were then removed and the heat production estimated as quickly as possible.

It was not possible to reduce the period from the time of removal of the muscle from the O₂ pressure to the time of observing stimulation to less than 20 minutes, 10 minutes for fixing, and 10 minutes for observing curve ; and sometimes it took longer to attain settled conditions in temperature of the flasks. The results of these experiments were :

¹ A method of avoiding this contingency by estimating the heat production of chloroform rigor after fatigue upon the muscles in the actual flask used for determining the heat production of stimulation I tried at first, but was obliged to abandon as the errors involved in measuring the slow heat production of chloroform rigor in the apparatus designed for measuring the heat production were too great.

² The pressure of oxygen used was one atmosphere.

TABLE V.

Stim. lasted, mins.	Exp. No.	Time of oxygen, mins.	Limb weight	Muscle weight	Muscle vol.	Stim. rate per sec.	H. P. of stim. in S.D.	No. of limb	Heat per gm. cal.	Temp. °C.	Ext. temp. °C.
8	18	90	27·29	17·2	27	16	76	4	·88	14	13·8-14·0
10	19	50	30·67	18·1	29	20	40	4	·67	13·8	13·0-14·0
7	20	45	29·38	19·0	27·5	11	70·5	4	·76	14·3	13·8-14·3
6	21	60	27·19	16·25	24·5	16	76	4	·94	15·8	16·0

It will be seen that the heat production per gram of muscle varied from ·70-·94 calories, which is not greater than the value obtained for muscles which had not been treated with oxygen.

The experiments indicate that the muscle cannot store oxygen but are not decisive, since the pressure may not have been sufficiently high to drive the oxygen into the muscle substance, or the time necessarily elapsing between the estimation of the heat production and the removal from the pressure bottle, may have allowed the escape of any oxygen that had penetrated the muscle substance. So far as the experiments can be trusted, however, they seem to indicate that the muscle cannot store oxygen as such, a conclusion which has been reached by other observers. An experiment of the nature of those in this paper, but employing direct stimulation, should be able to settle the question definitely.

Production of lactic acid. As was stated above, it was shown by Hill that there was a close relation between the production of lactic acid and the liberation of heat. Now it was shown by Fletcher and Hopkins that there was a maximum production of lactic acid varying in different months between about ·35-·55% (measured as Zn lactate) in summer, ·4% approximately. When they stimulated to fatigue over varying periods of time and for different strengths of current, they obtained values for fatigue of about half those obtained in total rigor. To quote their words, "The average percentage yield is ·216%, of which the highest yield was ·28%, the lowest ·147%, and 13 of the determinations lay between ·18-25%. One experiment in which stimulation through the sciatic plexuses was employed, gave a yield of ·203%."

In the introduction to this paper, it will be remembered that one of the objects in view was to establish further the fact that any process tending to liberate lactic acid in a muscle tended to liberate heat, which has been confirmed by the values for heat production obtained. Still further another point would seem to be established, namely, that in contraction heat production and lactic acid liberation are extremely

intimately connected, for in each case, that of the heat production and the lactic acid yield, we obtain about half the maximum yield of chloroform rigor.

It remained still to prove that the method of indirect stimulation in this paper did yield about half the amount of lactic acid; in order to confirm or disprove this, muscles were prepared and stimulated in exactly the same manner as in the experiments, so as to afford the same amount of handling as far as possible. In the estimation of the lactic acid it is not possible to balance the resting lactic acid production, and that due to handling etc., as in the experiments upon the heat production, and therefore an experiment was done to test the order of lactic acid formation in limbs unstimulated, but handled as in the experiments. As far as the experiments go, they confirm the application of this paper to the results of Fletcher and Hopkins.

In the estimation of the lactic acid, I have received much help from Drs Fletcher and Hopkins, and have used their method as far as the ether extraction, that is to say, grinding in ice-cold alcohol, allowing to stand, squeezing through muslin, evaporating, taking up in water, and boiling with charcoal. After obtaining the filtrate from the charcoal, I used C. G. L. Wolf's¹ method of total extraction with ether in some cases and that of Fletcher and Hopkins in others.

After some of the total extractions, the residue was treated with lead carbonate before the zinc carbonate to ensure additional purity.

TABLE VI. *Estimations of lactic acid. Temp. 17-19° C.*

Exp. No.	No. of limbs	Condition	Height of limbs	Weight of muscle	Zn lactate %	Remarks
22	10	Resting 1-34 hrs.	52.78	24.47	.11	Extraction (Wolf). Treated with lead.
23	10	Stimulated	57.29	32.54	.29	Do. (Residue slightly pigmented.)
24	10	„	67.22	34.66	.22	Extraction (Wolf). Treated with Pb.
25	10	„	53.76	26.09	.205	„ „ „
26	10	„	93.07	54.53	.24*	Extraction (Fletcher and Hopkins).
27	10	Chloroform rigor after fatigue	73.42	48.70	.55	Extraction (Wolf). Treated with lead.

Where the muscles were stimulated in Ringer's fluid, the latter was evaporated, extracted with alcohol and added to the main muscle extract.

* This Zn lactate estimated by the original method of Fletcher and Hopkins is in good agreement with their results.

¹ Dr C. G. L. Wolf has not yet published the detail of this method. I have to thank him very much for his help and for the loan of his apparatus for the extraction.

In all cases where stimulation was employed, rate was 14–16 per sec. and stimulation at intervals for a total time of 5–10 minutes.

The results are of the same order as those of Fletcher and Hopkins, but slightly on the high side. This is what would be expected, taking into account the total ether extraction employed in most cases, and in the case of the stimulated muscles, the necessary handling in dissecting out the preparations. In Exp. 22, there is an attempt to form some idea of the amount of acid that may be present in muscles, which have been treated exactly as in Exps. 23, 24, 25, and 26, with the exception that they have not been stimulated. The yield of acid is seen to be rather high, especially when compared with the resting minimum of Fletcher and Hopkins of .02%, but it must be remembered that the latter was obtained by placing the frogs after pithing upon ice and cutting off the limbs while cold, whereas in the experiments in this paper the muscles were kept in a physiological condition for subsequent stimulation.

Discussion of Results.

It has been seen that the maximum heat production of contraction to a condition of fatigue in an excised frog's muscle is not (as might be perhaps expected) considerably larger than that of chloroform rigor in the fresh muscle, but is in fact about one half of its value; and further the heat production of the chloroform rigor in the fatigued muscle will account for the other half of the heat production, so that contraction seems to make calls upon the same process as does the condition of rigor.

The ratio of the heat production of fatigue to that of chloroform rigor,—one of approximately one half,—would seem to have an interesting connection with the experiments of Fletcher and Hopkins upon lactic acid, in which they found a ratio of the same order. The relative constancy of the ratio would seem to merit further investigation, as it is possible it is dependent upon some property of the muscle. Also I have observed in these experiments a point which Dr Fletcher has told me that they observed in their experiments upon lactic acid production, namely that upon reaching a certain point of fatigue—a point which was reached extremely quickly—further stimulation seemed to be without much influence upon the heat production. At first, I noted most carefully that the first periods of stimulation and second etc. should agree in duplicate experiments, but later I found that provided the stimulation had taken 4–6 mins. altogether, the greatest

part of the heat production had always appeared. This maximum appearance too seemed in many cases to be before the complete cessation of irritability; a suggestion of the same fact, Dr Fletcher has told me, was observed by them for lactic acid production.

Another point which has appeared in every curve of heat production obtained in this paper, is that over the time during which the heat production is observed (it appears in Figs. 3 and 4), equal amounts of heat are not obtained in equal periods of stimulation, approximately 80% of the heat appears in the first 2-3 minutes of stimulation. In the curves of liberation of the substances causing contraction and rigor therefore, there seems to be a difference between liberation leading to contraction and leading to rigor, in the former case the liberation is more or less exponential, in the latter linear. This character coupled with the other observations in the paper makes it probable that the second explanation of Fletcher and Hopkins¹ for the fatigue ratio of lactic acid is the true one, namely that the "lactic acid of fatigue stops short, self-impeded at a relatively low level." The exponential character of the heat production of stimulation would admit of the possibility of this 'self-impeding' being due to the accumulation of the substance (?lactic acid) causing contraction in a small place, the cessation of liberation arriving when the acid had reached the highest concentration possible at the place of liberation. In the end, the liberation would be infinitely slow. A simple explanation of this character, however, would not explain the splitting off of acid during the onset of rigor, in which the relation is a linear one. In this connection, the work of Embden and Kondo² is suggestive, in which they show that the production of acid seems to be dependent upon the hydrogen ion concentration of the muscle juice. Mines has pointed out that the liberation of acid probably takes place in extremely localised positions, from which it diffuses away into the general substance of the muscle, or is removed from the positions of action.

A further point arising from this paper, which needs discussion, is whether the heat which has been measured is solely a heat production concerned with the appearance of lactic acid. That lactic acid is the main body appearing in the process of contraction, we know from the work of Fletcher and Hopkins; and therefore that the heat must be concerned mainly with the lactic acid, it is possible to say with a fair degree of certainty, but until we know that nothing but lactic acid

¹ Fletcher and Hopkins. *This Journal*, xxxv. p. 281. 1907.

² *Biochem. Ztsch.* xlv. p. 69. 1912.

appears in contraction and rigor it does not seem possible to say that the heat is concerned solely with the lactic acid that appears.

Hill¹ has given some evidence to show that in the presence of oxygen the heat production for short periods of tetanus occurs in two stages. If we accept the view that the process leading to contraction occurs in two stages, one the breakdown of a precursor (*A*) to the substance (*B*) causing contraction, the other the removal of the substance (*B*) causing contraction from the point of liberation, the two stages of heat production, as Hill suggests, will measure (1) $A \rightarrow B$ and (2) removal of *B*. Stage (2) occurs according to his view only in the presence of oxygen. If the experiments in this paper are correct, and the muscle cannot store oxygen, but only makes a contemporary use of it in preparation for a subsequent contraction, a view that has been substantiated by the experiments of Verzár upon the time relations of the oxygen removal from the blood supplying a contracting muscle (as mentioned above) it would seem that the heat production measured by the methods of this paper for periods of contraction, has been that of stage (1) only.

SUMMARY AND CONCLUSIONS.

With a view to testing current hypotheses of muscular contraction, from the standpoint of heat production, especially as to whether the processes of contraction and rigor call upon the same body as precursor, Hill's differential calorimeter has been modified for the purpose of measuring the heat produced during the indirect stimulation to fatigue of frog's limbs through the sciatic plexus. The conclusions which have been reached are that :

1. The heat produced during the indirect stimulation of frog's muscles to a state of fatigue in atmospheric air has a maximum value approximating to 0.9 cal. per gram of muscle tissue. The heat liberation is roughly exponential, about 70-80% being liberated in the first 2 mins. of tetanus.

2. This quantity bears a ratio of about one half to the heat produced in the rigor caused by the poisoning action of chloroform upon the muscle substance, for which a value of 1.70 cal. per gram is obtained.

3. The heat liberated in chloroform rigor induced after indirect stimulation to fatigue has a value approximating to 0.87 calorie per gram.

¹ A. V. Hill. *This Journal*, XLVI. p. 28.

4. Thus the sum of the heat produced during such a contraction, and the heat produced after it by chloroform rigor, is approximately equal to the heat production of chloroform rigor in the fresh muscle. This result confirms the argument, from the lactic acid and heat production in rigor and contraction, that no processes of importance arise in the production of rigor other than are involved in muscular contraction.

5. Estimations of the lactic acid produced under the experimental conditions of the heat measurements agree with those of Fletcher and Hopkins for fatigue and rigor. Hence the heat production and lactic acid liberation are extremely intimately connected.

6. By exposing the muscle to pressures of one atmosphere of oxygen for one hour before the experiment, some evidence shows that the heat production of contraction is not increased.

Besides the thanks which I have expressed in the paper I should like to express my warmest gratitude to Mr A. V. Hill for his kind help throughout this research, and to Dr Fletcher for his most helpful criticism.

(The expenses of this research have been defrayed in part by a grant from the Thruston Memorial Fund, Gonville and Caius College, and in part by a grant from the Royal Society.)