

DYNAMIC RHEOPTICAL BEHAVIOR OF ISOLATED BOVINE CORNEA

DONALD KAPLAN *and* FREDERICK A. BETTELHEIM

From the Chemistry Department, Adelphi University, Garden City, New York 11530

ABSTRACT The dynamic Young's modulus E' and loss modulus E'' were obtained for isolated bovine cornea using a direct-reading dynamic viscoelastometer. Within the temperature range (0–60°C) and frequency range (3.5–110 Hz) studied, both moduli were temperature and frequency independent. The dynamic birefringence of the cornea was measured in a special apparatus designed for this purpose in conjunction with the dynamic viscoelastometer. The stress-optical and strain-optical coefficients as well as the corresponding phase angles were evaluated as a function of temperature and frequency. The strain- and stress-optical coefficients were both temperature and frequency dependent.

INTRODUCTION

Previous investigations on the light-scattering (1, 2), birefringence (3), and mechanical properties (4) of isolated bovine cornea were performed under static conditions and/or with transient techniques. These studies indicated that the local optical anisotropy is symmetrically distributed within the resting cornea and that it is largely due to the birefringence caused by the preferential orientation of collagen fibrils in the different parts of cornea. Cornea under unidirectional stress will undergo change in the opticomechanical properties which can be explained by a three-step mechanism involving (a) straightening out the waviness of collagen fibrils, (b) slippage and rotation of individual lamellae, and (c) breakdown of aggregated molecular superstructures into smaller units.

The dynamic response of the cornea at low frequencies is of great physiological importance. Schwartz et al. (5) related studies on corneal segments to the rigidity of the whole eye. McEwen and coworkers (6–8) applied corneal and scleral segment data to the whole eye modeling. Their conclusion, however, was that segments and strips cannot be related to the whole eye with any degree of precision. In our case, we restrict our investigations to the isolated cornea and no correlation will be attempted with the mechanical behavior of the whole eye. Opticomechanical properties measured under small strains varying sinusoidally at low frequencies may provide insight into the macromolecular organization of cornea and into the changes caused by small strains. If a relationship to the mechanical properties of the cornea

during the *in vivo* deformations is to be established, then the time scale used to measure the dynamic optomechanical properties must be the same as the accommodation time (1 sec or less). In cornea *in vivo* one is concerned with vibrations in the order 0.1–100 Hz which may have amplitudes ranging from 0.01 mm to a few millimeters. The origin of these vibrations are threefold: (a) rapid contraction and relaxation of individual muscle fibers (microvibration), (b) pressure waves transmitted from the heart to the tissues by the blood vessel system, and (c) vibrations coming from the environment (9).

Therefore, it was decided to investigate the optical and mechanical properties of cornea under sinusoidally varying stress within the abovementioned range.

MATERIALS AND METHODS

Materials

Adult bovine eyes (2 years old) were obtained from slaughterhouses 1 day postmortem. The cornea was removed from the eye and inspected for perfect transparency, and corneal strips were obtained by cutting along two directions (Fig. 1). One type of cut was along the

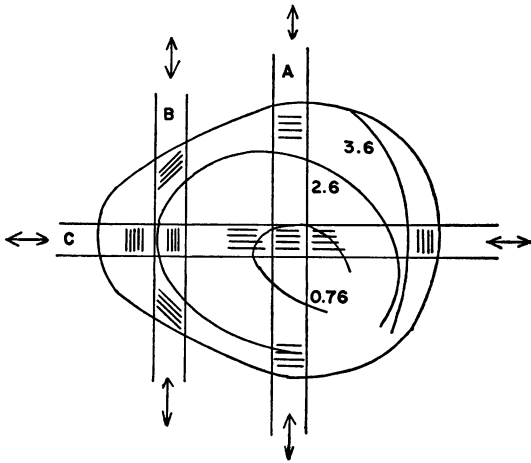

FIGURE 1

FIGURE 1 Different types of cuts used to obtain strips from the isolated bovine cornea. (A) In the meridional and (C) in the equatorial direction. The curved lines are isochores of equal birefringence ($\times 10^4$) formed in a typical cornea (3). The parallel lines indicate the local preferential orientations of the collagen fibrils.

FIGURE 2 Schematic diagram of dynamic birefringence apparatus. A, laser; B, polarizer; C, sample, D, quarter-wave plate; E, analyzer; F, photoresistor; G, power supply; H, oscilloscope; I, driving motor; J, stress gauge; K, air pump; L, cold bath; M, thermocouple; N, meter; O, heater; P, transformer.

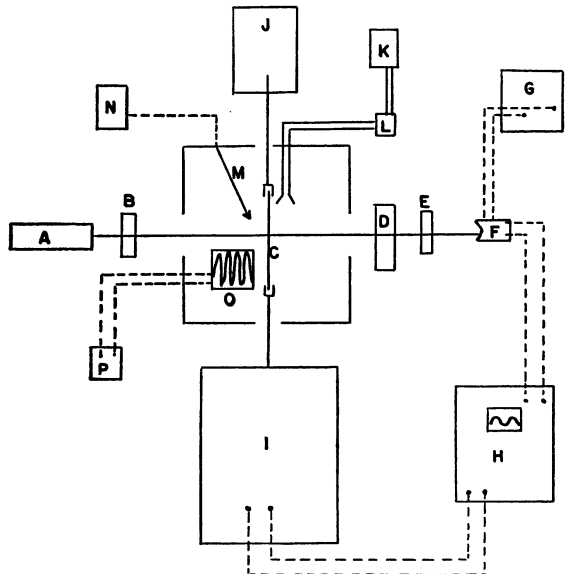

FIGURE 2

short geometrical axis of the cornea, strip A, and one type along the long geometrical axis, strip C. Details of the cutting procedure have been given previously (4).

Instrumentation

A "Vibron" direct-reading dynamic viscoelastometer model DDV-II (Toyo Measuring Instrument Co., Ltd., Tokyo, Japan) was used for both the dynamic mechanical and birefringence measurements. The Vibron applies a sinusoidal strain to a sample strip by an electromagnetic transducer. The displacement and force are detected electrically by two strain gauges connected to the clamped ends of the specimen. The electrical output from the two strain gauges are amplified and the phase separation detected by the use of a potentiometer and can be read directly on a meter ($\tan \delta$).

$$\tan \delta = E''/E', \quad (1)$$

where E' and E'' are the real and imaginary component of the dynamic modulus

$$E^* = E' + iE'', \quad (2)$$

and the complex dynamic Young's modulus E^* is obtained from the expression

$$E^* = \frac{\Delta f}{A} \cdot \frac{L}{\Delta L}. \quad (3)$$

In the above equation ΔL is the amplitude of the oscillating displacement, L is the length and A is the cross-sectional area of the specimen, and Δf is the force amplitude obtained from the potential D needed to balance a bridge circuit fed by the output of the force transducers and from the instrument constant K' ; $\Delta f = K'/D$.

In order to measure the dynamic birefringence, the Vibron was used in conjunction with an optical bench (Fig. 2). The laser beam (654.1 nm) was used as a light source which was perpendicular to the sample surface. The sample was strained by the oscillating chucks of the Vibron and both displacement and force were measured with the Vibron. The laser beam was polarized 45° to the stretching direction. Oscillating strain was superimposed upon a static strain. Static birefringence was measured by the quarter-wave plate method.

To measure the oscillating birefringence, the intensity of light impinging on the photoresistor (Clairex C1-3, Clairex Electronics, Inc., Mount Vernon, N. Y.) was fed into a dual-beam oscilloscope. The intensity of light is directly proportional to the retardation and was calibrated by using the quarter-wave plate method. The variation of light intensity was read on the vertical axis of the oscilloscope and the stress or strain from an output jack of the Vibron was connected to the horizontal axis of the oscilloscope. The phase difference was measured by Lissajous's figure (curves due to combinations of two simple harmonic motions) or hysteresis loop method. Photographs of the oscilloscope were taken with an oscilloscope camera (C-12 camera, Tektronix, Inc., Beaverton, Ore.). The camera consists basically of a Polaroid Land camera on a mounting assembly with a special lens system.

In order that the Δf values should be large enough to obtain Lissajous's figures a static strain of 18–20% was needed. Thus, the L in equation 3 was the length of the resting cornea and the superimposed static strain on it. This static strain was held for sufficient length of time (10 min) before the beginning of the dynamic experiment so that stress relaxation equilibration did occur.

A check was made upon the frequency response of the light intensity recording system. A strobe light (Stroboslave, General Radio Co., Concord, Mass.) was used as a light source which flashed light of the same intensity at the four frequencies of vibration to be used. An adjustment was needed in the variable resistor of the photoresistor circuit before the response of the system was made independent of frequency. The optical coefficients were read at frequencies of 3.5, 11, 35, and 110 Hz.

Temperatures were monitored by a thermocouple supplied with the Vibron which was placed near to the locus of entry of the laser beam into the sample. The higher temperatures were obtained by a system of heating coils which were controlled by a variable transformer. The lower temperatures were obtained by flowing cool air directly over the sample. An air pump was used which ran air through aluminum coils in a dry ice-acetone bath. The range of temperatures was 0–60°C. Samples were enclosed in a windowed enclosure for thermal insulation, but it was found that above 40°C the water vapor condensed on the glass windows thus giving large scattering of light. At 40°C and above the glass windows were removed and a small hole remained in the walls of the insulating box allowing the passage of the laser beam. The system was still sufficiently insulated to allow temperature control. Above 40°C if no preventative measures are taken the cornea loses water with consequent shrinkage and stiffening of the sample. In order to prevent this a reservoir of water was placed under the sample. This reservoir kept the relative humidity near its saturation point (~1.0) at each temperature and kept the cornea moist and its thickness almost constant.

Stress- and strain-optical coefficients, M^* and K^* , and the phase angles α and β were measured as a function of frequency of vibration and temperature. These are defined as follows:

$$M^* = \frac{\Delta n_0}{\sigma_0} = M' + iM'', \quad (4)$$

$$K^* = \frac{\Delta n_0}{\epsilon_0} = K' + iK'', \quad (5)$$

$$\tan \alpha = \frac{K''}{K'}, \quad (6)$$

$$\tan \beta = \frac{M''}{M'}, \quad (7)$$

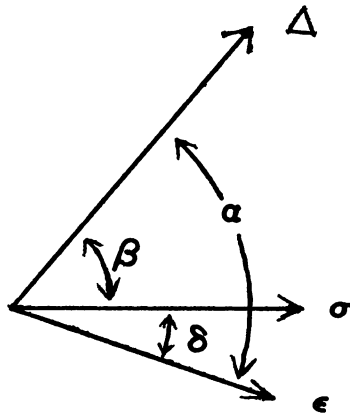

FIGURE 3 The relationship between the three phase angles α , β , and δ .

where ϵ_0 , σ_0 , and Δn_0 are the strain, stress, and birefringence amplitudes, respectively, α is the phase angle between strain and birefringence, and β is the phase angle between stress and birefringence. When measuring birefringence, by the shape of the hysteresis loop, only δ and β phase angles can be obtained.

The reason is that in order to read $\tan \delta$ the phase of strain has to be manipulated to match that of the stress on the oscilloscope, thus a direct reading of the nonadjusted strain is impossible. The phase angle α must be obtained from adding or subtracting δ from β (see Fig. 3).

RESULTS

Mechanical

In Fig. 4 the dynamic modulus E' and the dynamic loss modulus E'' are plotted against temperature for a C type cut strip. Fig. 5 shows the loss tangent ($\tan \delta$) plotted against temperature. There is very little temperature dependence at all. The results show no maxima or minima and therefore no absorption due to a particular

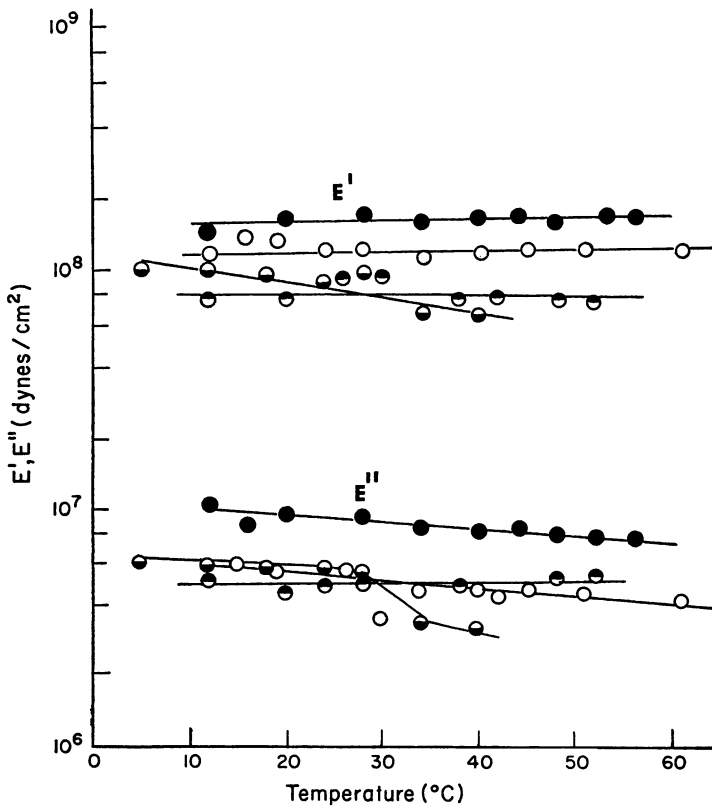

FIGURE 4 Dynamic modulus E' and dynamic loss modulus E'' of type C cut strips of bovine cornea as a function of temperature at ●—● 110; ○—○ 35; ●—● 11; and ○—○ 3.5 Hz frequencies.

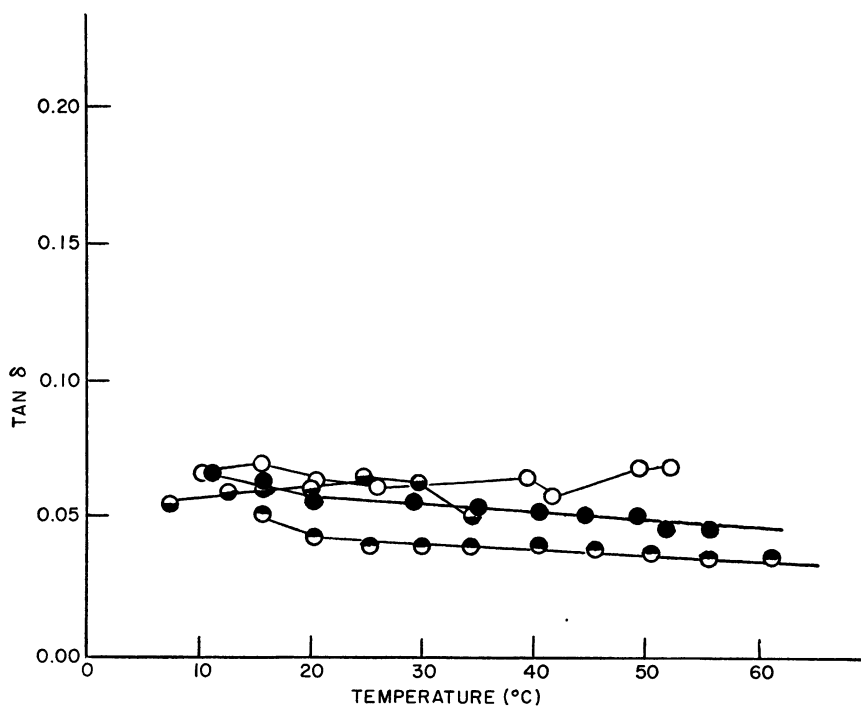

FIGURE 5 Loss tangent of type C cut strips of bovine cornea as a function of temperature at ●-● 110; ○-○ 35; ◐-◐ 11; and ◑-◑ 3.5 Hz frequencies.

mechanical relaxation can be assigned. There is little dispersion due to temperature. The $\tan \delta$ values fall in the range of about 0.05–0.07, which corresponds to a phase-angle difference between stress and strain of about 3–4°. The complex modulus E^* was found to be about $1-2 \times 10^8$ dynes/cm². The same results were obtained from strips of A type cuts with no apparent difference from strip to strip.

A check was made to see if evaporation of water from the sample at 24°C played any major role in the physical properties. Fig. 6 shows a plot of E' and E'' as a function of time at 24°C and a frequency of 110 Hz. No change was observed over a 35 min period, which is within the time limit of each experimental run. The rate of evaporation of the corneal stroma was too slow to effect the Young's moduli at room temperature. This indicates that stress relaxation equilibration did occur in the sample before the start of the dynamic experiment.

Birefringence

A periodic strain on the cornea produced a periodic change in light intensity. Fig. 7 shows the pictures taken of the oscilloscope at a frequency of 3.5 Hz of a type A cut sample. Fig. 7 A shows the stress varying sinusoidally above the strain, which also varies sinusoidally. Fig. 7 B shows a Lissajous's figure of the combina-

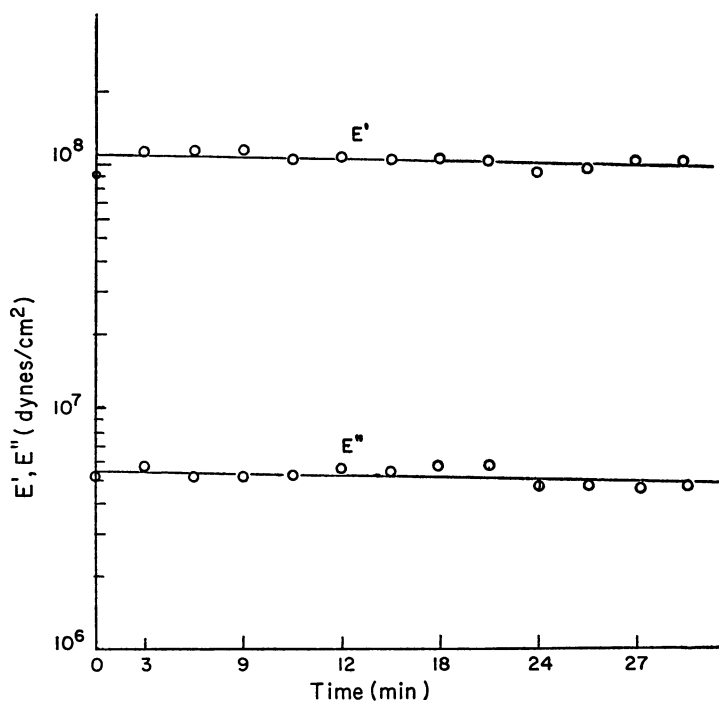

FIGURE 6 Dynamic modulus E' and loss modulus E'' of bovine corneal strip as a function of time at 24°C and at 110 Hz frequency.

tion of these two waves. Fig. 8 is the oscilloscope pattern of two different strips of a type A cut at frequency 3.5 Hz. The stress is indicated above the light intensity variation. The combination of these two waves form the Lissajous's figures of the type shown in Fig. 9.

Two things can be noted here. (a) The birefringence does indeed vary harmonically along with stress and strain. Phase angles between stress and birefringence were found to be from 65 to 70°. (b) The birefringence waves were not as smooth or sinusoidal as the stress but consisted of several peaks or shoulders. The resultant Lissajous's patterns were not, therefore, perfect ellipses. Not only phase angles can be deduced from the Lissajous's figures. From the direction which the oscilloscope beam travels, it was determined that the phase angle of birefringence was ahead of the phase of stress. Fig. 10 shows K^* and M^* plotted as a function of the log of frequency. The phase angles appear to be independent of frequency.

The functions K^* and M^* were found as a function of temperature at a frequency of 11 Hz for type A cut strip. K^* and M^* are plotted as a function of temperature in Fig. 11. Both show a marked increase in the birefringence amplitude with increasing temperature. No change in phase angles was observed. The behavior of the real and imaginary parts of the complex moduli is given in Table I.

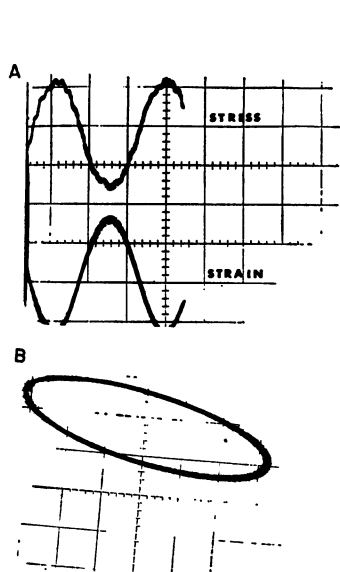

FIGURE 7

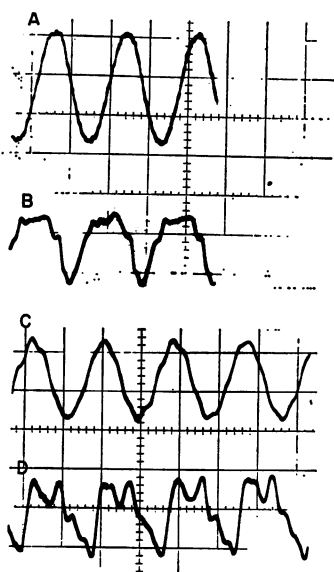

FIGURE 8

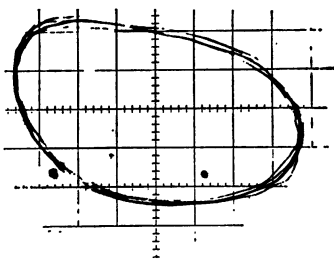

FIGURE 9

FIGURE 7 Oscilloscope photographs of A stress-strain variations and B of a Lissajous's figure of a type A cut strip of bovine cornea.

FIGURE 8 Oscilloscope photograph of stress and birefringence of two cornea. A and C are stresses and B and D are the birefringence of the two cornea.

FIGURE 9 Lissajous's figure of stress and birefringence of a type A cut bovine corneal strip of bovine cornea.

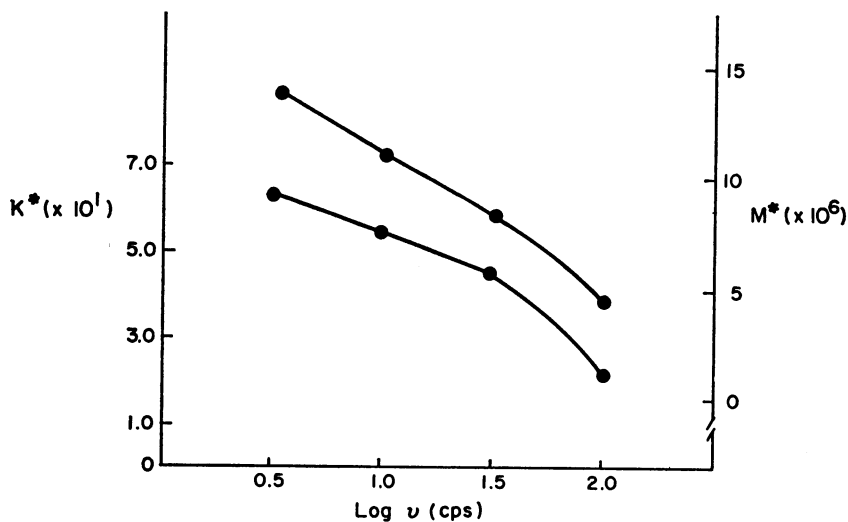

FIGURE 10 M^* and K^* as a function of frequency of vibration at 24°C.

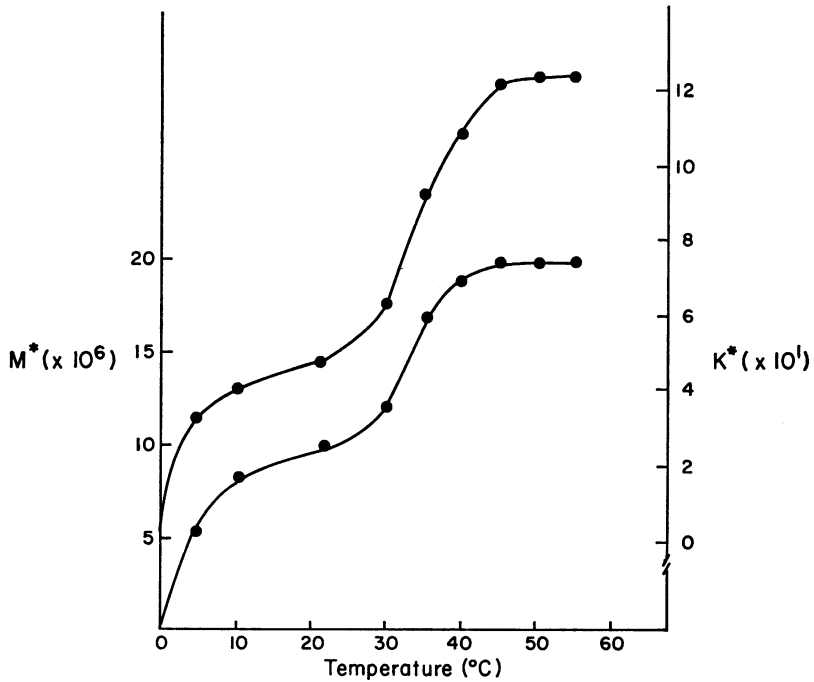

FIGURE 11 K^* and M^* as a function of temperature at 11 Hz frequency.

TABLE I
STRESS- AND STRAIN-OPTICAL COEFFICIENTS
AS A FUNCTION OF TEMPERATURES*

Temperature	Δf	M'	M''	K'	K''
$^{\circ}\text{C}$	$\times 10^{-3} \text{ cm}$	$\times 10^6$	$\times 10^6$		
0	5.28	0.0	0.0	0.0	0.0
5	4.52	3.0	5.2	1.5	3.0
10	3.96	4.5	8.0	1.8	3.7
22	4.00	5.6	9.2	2.2	4.4
30	5.52	6.5	11.0	2.9	5.9
35	4.86	9.0	16.0	4.4	8.9
40	5.26	10.0	18.0	5.1	1.0
45	5.26	11.0	18.0	5.8	1.2
50	5.44	11.0	18.0	5.8	1.2
55	5.79	11.0	18.0	5.8	1.2

* Frequency of 11 Hz, $\Delta L = 1.58 \times 10^{-3} \text{ cm}$, $\tan \beta = 2.48$, $\tan \alpha = 3.08$.

Below 5°C the light intensity amplitude (birefringence) of the oscilloscope went to zero. If the sample was allowed to rise back to 24°C , the birefringence amplitude also returned to its initial value. That is, at low temperatures the dynamic birefringence was completely reversible. At higher temperatures the sample was kept

moist with a reservoir of water as was done in the mechanical measurements. In contrast to the lower temperatures, however, the higher the temperature the less reversible was the birefringence.

DISCUSSION

The mechanical behavior of the cornea is quite similar to the mechanical behavior of collagen fibers of rat tail tendon (10). The dynamic modulus of cornea (Fig. 4) is about $\frac{1}{10}$ of that obtained by Mason and Unsworth (11) for bovine Achilles tendon under similar frequencies and loads. The temperature independence of the loss tangent (Fig. 5) up to 60°C has also been observed with bovine Achilles tendon (11), and they obtained essentially the same $\tan \delta$ value as we had in cornea.

The fact that the dynamic moduli E' were also frequency independent and 10–15 larger than the dynamic loss moduli E'' indicated that we are dealing essentially with an elastic behavior of the cornea, and therefore, the contribution of the viscous components are small. One can identify the elastic component with collagen fibers and the viscous components with the acidic polysaccharides in a connective tissue matrix. Other physicochemical measurements, especially thermal characteristics measured by Rigby, also indicated that admixed proteins and polysaccharides in collagenous tissues do not alter appreciably the behavior of native collagen (12).

In our previous study on the mechanical behavior of cornea under unidirectional static loads (4) we proposed that at low elongations, up to 5–7%, the reversible elastic behavior is due to configurational entropy of collagen fibers. At intermediate elongations the fibers align in the direction of the stretch by a rotation and slippage mechanism of the individual lamellae. Since the vibratory oscillations on the cornea were superimposed upon a static strain of 18–20% we were beyond the first (reversible) stage of the mechanism. The low $\tan \delta$ and E'' values indicate that energy dissipation due to the oscillation is small. This must mean that the mechanical oscillations superimposed upon the static strain permit only short range molecular motions. The viscoelastic measurements alone are rather insensitive to differentiate whether we deal with glassy, crystalline, or rubbery state within the experimental range. The birefringence behavior would however, exclude the presence of a rubber-like model.

Both type A and type C cuts of corneal strips gave similar results (within the limit of individual variation from cornea to cornea). With transient techniques (4) these two types showed different behavior throughout the whole extension range because of the different collagen fiber alignments in the two types of strips in the resting sample and their different degrees of orientation in the stretched samples. Since no appreciable difference was evident between the two types of cuts in the dynamic viscoelastic measurements, it must be that the mechanical oscillation causes short range molecular motions independent of the fibril orientation.

The decrease in stress- and strain-optical coefficient with increase in frequency

(Fig. 10) or decrease in temperature (Fig. 11) indicated that the molecular segmental motions responsible for the birefringence cannot follow the more rapid oscillations, on the one hand, and are enhanced by the thermal motion of the matrix at high temperatures, on the other.

Molecular interpretations of dynamic birefringence can be based on either of two mechanisms. "Orientation" birefringence is involved with motions of long chain segments of macromolecules or fibers. "Distortional" birefringence deals with local bending of valence angles or local twisting around of main chain bonds against rotational barriers. These distortional motions, however, would not be frequency dependent at 3.5–110 Hz.

In the cornea, the birefringence is of the orientation type. In the orientation of fibers, an increase in frequency is usually associated with a decrease in K^* and M^* . The larger the chain length associated with the motion, the larger the frequency dependence. The nondependence of E' and E'' on frequency and temperature would simply indicate that the viscoelastic measurements are insensitive to these motions within the experimental range.

A third contribution, namely, the form birefringence, plays an important role in the resting cornea (13). The form birefringence, however, is not important in the change in birefringence due to small mechanical oscillation, since one does not expect that the anisotropic needle shape of collagen fibers breaks down during the oscillation nor does one expect a change in the refractive index of the embedding matrix.

At high temperatures, 35°C and above, denaturing occurs and the system breaks down showing hysteresis. It is interesting to note that temperatures of 104–105°F (approximately 40°C) are not uncommon in humans during illness. Rigby et al. (6) have pointed out that, for example, rheumatic fever can cause permanent heart damage because of an alteration of the collagen. Although it is speculative one may assume such an occurrence in other collagen containing connective tissues.

The nature of the curves in Fig. 11 indicates a two-step process as a function of temperature that was not evidenced in the mechanical properties. At low temperatures especially between 0–10°C the melting of the ice structure of water (solvent effect) may allow increased freedom for segmental motions.

Above 30–35°C an irreversible change occurs which may be associated with the deeper penetration of water into the areas where the macromolecules were hydrogen bonded or interacted between themselves. The result would be a higher degree of solvation of individual macromolecular segments which will result in enhanced segmental motion.

The values of $\tan \alpha$ and β varied between 2–3 for different cornea; the $\tan \alpha$ being with about 0.5 larger than $\tan \beta$. They were both temperature and frequency independent. These values are 500-fold greater than $\tan \delta$. That means that the stress- or strain-optical *loss* coefficient is more important than the stress- or strain-

optical coefficient again indicating that the birefringence is dissipated in the oscillatory process.

This research was supported by a grant EY00501-04 of the National Eye Institute, National Institutes of Health, U.S. Public Health Service.

Received for publication 22 May 1972 and in revised form 19 July 1972.

REFERENCES

1. BETTELHEIM, F. A., and M. J. VINCIGUERRA. 1969. *Biochim. Biophys. Acta.* **177**:259.
2. CEJTLIN, J., M. J. VINCIGUERRA, and F. A. BETTELHEIM. 1971. *Biochim. Biophys. Acta.* **237**:530.
3. KAPLAN, D., and F. A. BETTELHEIM. 1972. *Exp. Eye Res.* **13**:219.
4. KAPLAN, D., and F. A. BETTELHEIM. 1972. *Biochim. Biophys. Acta.* **279**:92.
5. SCHWARTZ, N. J., F. S. MACKAY, and J. C. SACKMAN. 1966. *Bull. Math. Biophys.* **28**:585.
6. MCEWEN, W. K., and R. ST. HELEN. 1965. *Ophthalmologica.* **150**:321.
7. LYON, C., W. K. MCEWEN, and M. D. SHEPHERD. 1970. *Invest. Ophthalmol.* **9**:935.
8. HIBBARD, R. R., C. S. LYON, M. D. SHEPHERD, E. N. MCBAIN, and W. K. MCEWEN. 1970. *Exp. Eye Res.* **9**:137.
9. BALAZS, E. A. 1969. Aging of Connective and Skeletal Tissue. Thule International Symposia. Nordiska Bokhandeln, AB., Stockholm, Sweden. 107.
10. RIGBY, B. J., N. HIRAI, J. D. SPIKES, and H. EYRING. 1959. *J. Gen. Physiol.* **43**:265.
11. MASON, P., and J. UNSWORTH. 1971. *Kolloid Z. Z. Polym.* **249**:1101.
12. RIGBY, B. J. 1967. *Biochim. Biophys. Acta.* **133**:272.
13. MAURICE, D. M. 1969. In *The Eye*. H. Dawson, editor. Academic Press, Inc., New York. 489-585.