

REVIEW

**The bone marrow: the major source of serum immunoglobulins,
but still a neglected site of antibody formation**

R. BENNER,* W. HIJMANS† & J. J. HAAIJMAN‡ * *Department of Cell Biology and Genetics, Erasmus University, Rotterdam*; † *Study Group for Medical Gerontology, Department of Pathology, University Medical Center, Leiden*; and ‡ *Institute for Experimental Gerontology, Organization for Health Research TNO, Rijswijk (ZH), The Netherlands*

(Accepted for publication 13 February 1981)

SUMMARY

Immunoglobulin (Ig) secreting cells occur in all lymphoid tissues, including the bone marrow (BM). There are important differences between the various organs with respect to their number of Ig-secreting cells and the heavy chain isotype distribution of the secreted Igs. Furthermore, both distribution patterns depend on age. Early in life most Ig-secreting cells are localized in spleen and lymph nodes. In adults, however, the majority of all Ig-secreting cells of the individual are localized in the BM. Immunization can lead to the appearance of substantial numbers of antibody-forming cells in the BM. The kinetics of the BM response are different from the response in the peripheral lymphoid tissues. Shortly after immunization most antibody-forming cells occur in the peripheral lymphoid tissues, but later on, especially during secondary type responses, most antibody-forming cells are localized in the BM. Apparently, antibody formation is regulated in such a way that peripheral lymphoid tissues respond rapidly, but only for a short period, whereas the BM response starts slowly, but takes care of a long-lasting massive production of antibodies to antigens which repeatedly challenge the organism.

INTRODUCTION

It is remarkable that the BM has never generally been accepted as a site of antibody formation, in contrast to spleen, lymph nodes, gut-associated and bronchus-associated lymphoid tissues. This may be due to the fact that, until recently, the BM of the most popular experimental animal in immunological research, the mouse, was found to show little or no antibody-producing cells after immunization. Furthermore, spleen and lymph nodes are relatively easy organs to manipulate, in contrast to the BM. However, there is now compelling evidence that the BM actually is a major site of antibody production in humans as well as in experimental animals. This paper summarizes some data on antibody production in the BM.

EXPERIMENTS DEMONSTRATING Ig SYNTHESIS BY THE BONE MARROW

For the sake of clarity we must distinguish between experiments which demonstrate the production of Igs by BM cells, without taking into account the antibody specificity of these molecules, and

Correspondence: Dr R. Benner, Department of Cell Biology and Genetics, Erasmus University, PO Box 1738, 3000 DR Rotterdam, and Dr W. Hijmans, Study Group for Medical Gerontology, Department of Pathology, Leiden University Medical Centre, PO Box 9603, 2300 RC Leiden, The Netherlands.

experiments which demonstrate the production of specific antibodies in the BM upon immunization. Thus we will arbitrarily speak about Ig and antibody synthesis respectively.

All published studies in which Ig synthesis in the BM was investigated have yielded a positive answer. Igs are produced and released into the culture medium during short-term cultures of guinea-pig (Askonas & White, 1956; Askonas, White & Wilkinson, 1965), rabbit (Askonas & Humphrey, 1958; Thorbecke & Keuning, 1956), monkey (Asofsky & Thorbecke, 1961) and human (McMillan *et al.*, 1972; Van Furth, Schuit & Hijmans, 1966) BM cells. Wherever the Ig production by different lymphoid tissues from adult organisms was quantitated, the production was found to be the largest in the BM, especially when calculated per whole organ (Askonas & White, 1956; Askonas & Humphrey, 1958; McMillan *et al.*, 1972).

Ig synthesis also takes place in murine BM. The number of cytoplasmic Ig-positive plasmablasts and plasma cells (CIg cells) (Haaijman, Schuit & Hijmans, 1977; Haaijman & Hijmans, 1978; Haaijman *et al.*, 1979) and the number of Ig-secreting cells (Benner *et al.*, 1981a) in this organ is substantial as compared with the numbers in the other lymphoid organs. The contribution of the BM to the total of CIg cells is dependent on age. In 4-week-old BALB/c mice, only 17% of all Ig-secreting cells are localized in the BM. At that age spleen and lymph nodes are the major sites of Ig production. The absolute and relative contribution of the BM, however, increases enormously with increasing age. At 8, 14, 40 and 100 weeks of age the relative contribution of the BM was found to be 29, 46, 72 and 75% respectively (Fig. 1, *left*). A similar pattern was observed for CBA/BrA and C3H/f mice. The autoimmune strain NZB is an exception to the normal distribution pattern. At 4, 8 and 14 weeks of age the percentage contribution of the BM is the same as in age-matched BALB/c mice. However, after 14 weeks of age the percentage contribution of the BM to the total does not increase any more. This observation raises questions concerning the factors which direct the occurrence of Ig-secreting cells in the BM. Furthermore, the total number of Ig-secreting cells in NZB mice was much higher than in age-matched BALB/c mice (Fig. 1), a phenomenon which was described for a number of autoimmune-prone strains (Theofilopoulos *et al.*, 1980a, 1980b).

The heavy chain isotype distribution of the Ig-secreting cells in normal mouse BM is different from those in the other lymphoid organs, especially from that in spleen. IgG- and IgA-secreting cells are relatively frequent in the BM, in contrast to IgM-secreting cells (Haaijman *et al.*, 1979; Benner *et*

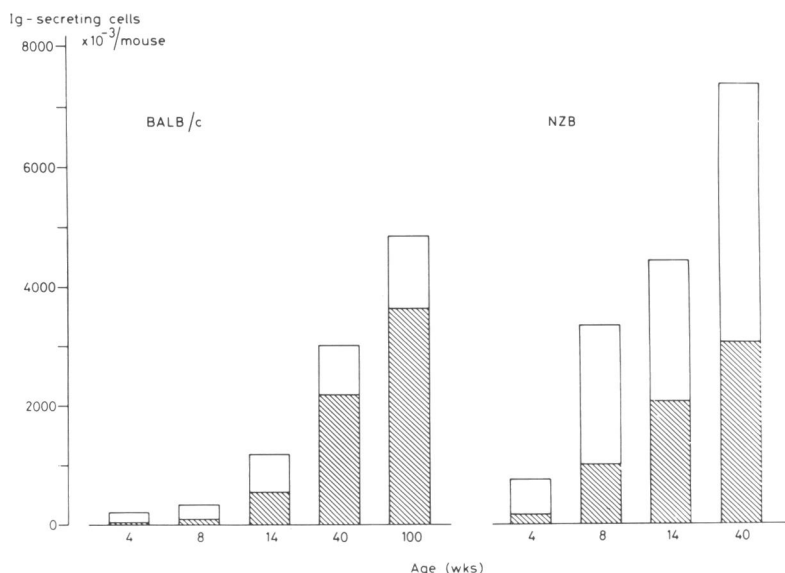

Fig. 1. Age-related increase of the total number of Ig-secreting cells in BALB/c (*left*) and NZB (*right*) mice. Ig-secreting cells were assayed in spleen, lymph nodes, bone marrow and Peyer's patches by means of the protein A plaque assay (Gronowicz, Coutinho & Melchers, 1976). Hatched areas represent the contribution of the bone marrow, open areas the contribution of spleen, lymph nodes and Peyer's patches together.

et al., 1981a). The reason for this different distribution pattern is unclear. The V-region repertoire of the IgM secreted by the BM cells is the same as that of IgM secreted by other lymphoid tissues (Benner *et al.*, 1981a). At present no data are available about the V-region repertoire of the IgG- and IgA-secreting cells in mouse BM and other lymphoid tissues.

The localization in the BM of the great majority of all IgG- and IgA-secreting cells of an adult mouse and their deficiency in germ-free mice (Benner *et al.*, 1981a) suggest that the IgG and IgA produced are predominantly directed against environmental antigens, which mainly penetrate via mucous membranes and the respiratory and digestive tract. However, it is not clear to what extent antibodies of the IgA class produced by cells within the BM contribute to the secretory IgA in the mouse. In humans the contribution of the BM to the secretory IgA is probably minimal, since the IgA produced outside the secretory sites is almost exclusively of the monomeric form (Radl *et al.*, 1974). In mice, BM-derived IgA might be secreted via the bile. Evidence for this pathway has been presented for rats and rabbits (Orlans *et al.*, 1978; Hall, Gyure & Payne, 1980).

For humans the shift of the majority of CIg cells to the BM as a function of age has been shown by Vossen (1974). There is a striking correlation between the heavy chain isotype distribution profile of the CIg cells in the human BM and the levels of the various Ig classes and subclasses in the serum. This has been shown for the following combinations: IgM-IgG-IgA (Hijmans, Schuit & Hülsing-Hesseling, 1971; Turesson, 1976), IgG1-IgG2-IgG3-IgG4 (Morell *et al.*, 1975), IgA1-IgA2 (Skvaril & Morell, 1974), monomeric IgA-polymeric IgA (Radl *et al.*, 1974) and IgD versus all other isotypes together (Van Camp *et al.*, 1978). Furthermore, the κ/λ ratio of the CIg cells in the BM correlated with the percentage distribution of the levels of Ig(κ) and Ig(λ) in the serum (Hijmans *et al.*, 1971; Turesson, 1976). The CIg cell distribution pattern in the other lymphoid organs, however, did not fit with the serum levels of the various Ig classes and subclasses. These data support the view that the human BM is the major source of all classes and subclasses of Igs in the serum.

EXPERIMENTS DEMONSTRATING ANTIBODY PRODUCTION BY THE BONE MARROW

Already in 1898, Pfeiffer & Marx reported that extracts of BM of rabbits which had been immunized with *Vibrio cholerae* contained specific antibodies. Almost simultaneously, Deutsch (1899) showed that immunization of guinea-pigs with typhoid vaccine led to the appearance of anti-typhoid antibodies in the BM. Although these pioneers did not formally prove that these antibodies were really produced within the BM, their data were suggestive for this view. Early in this century Lüdke (1912) and Reiter (1913) showed that BM cells from immunized animals release specific antibodies during *in vitro* cultivation. But the final proof that the BM actually produces antibodies upon immunization was given by Thorbecke & Keuning (1953). Subsequent studies on this aspect have been reviewed recently (Benner & Haaijman, 1980). At present, antibody formation in the BM has been demonstrated in frog (Eipert *et al.*, 1979), chicken (Jankovic, Isakovic & Petrovic, 1973), mouse (Benner *et al.*, 1974a; Hill, 1976), rat (Knothe, Herrlinger & Müller-Ruchholtz, 1979), mole rat (Jankovic & Paunovic, 1973), guinea-pig (Askonas & White, 1956; Askonas *et al.*, 1965), rabbit (Askonas & Humphrey, 1958; Thorbecke *et al.*, 1962) and man (McMillan, Yelenosky & Longmire, 1976; Vaughan *et al.*, 1976). In mice, antibodies of the IgM, IgG, IgA (Benner *et al.*, 1974a; Hill, 1976) and IgE (Gollapudi & Kind, 1975; Kind & Malloy, 1974) classes are produced by the BM.

Many studies in which the BM was investigated as a site of antibody formation yielded negative results. This appears to be especially true for mice immunized with T-dependent antigens (summarized by Benner & Haaijman, 1980). After primary immunization of mice with T-dependent antigens only small numbers of antibody-producing plaque-forming cells (PFC) appear in the BM (Benner *et al.*, 1974a; Chaperon, Selner & Claman, 1968; Mellbye, 1971). This PFC response in the BM peaks later than in spleen and lymph nodes, usually at least 2 weeks after immunization. When the antigen is administered together with adjuvant, PFC in the BM become numerous some months after immunization (Benner, van Oudenaren & Koch, 1981b).

Secondary immunization of mice with T-dependent antigens without adjuvant induces a high

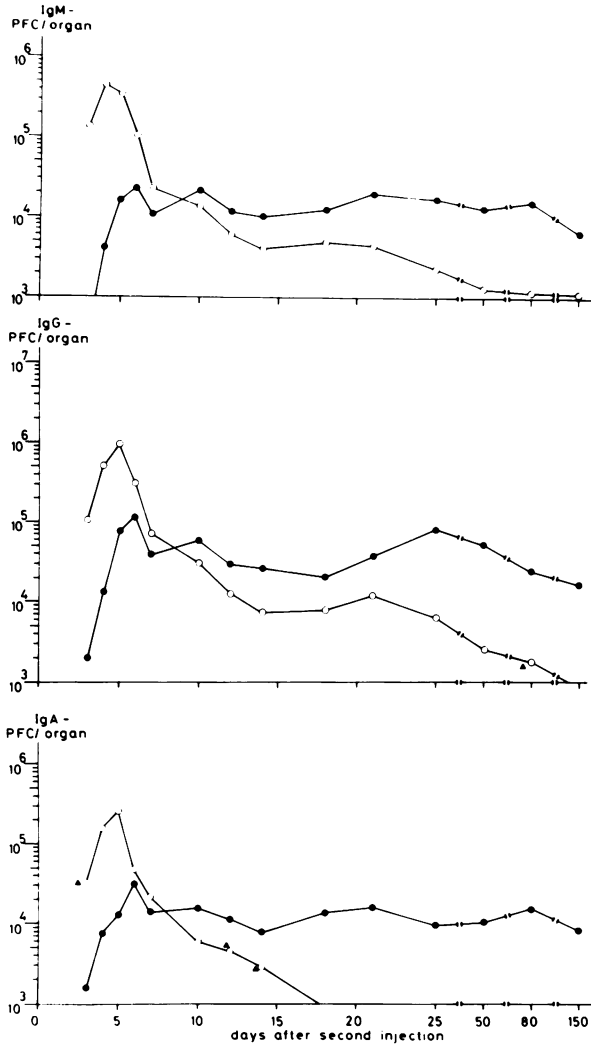

Fig. 2. Number of PFC in mouse spleen and bone marrow after two injections of sheep erythrocytes (SRBC). Mice were primed with 10^7 SRBC i.v. and boosted with 10^6 SRBC i.v. 2 months later. (o) Spleen and (●) bone marrow. Where (▲) is added to an experimental point it means that the number of IgG- or IgA-PFC above the level of IgM-PFC was not significant. [Reprinted from Benner *et al.* (1974b)]

PFC response not only in spleen and lymph nodes, but also in the BM. The first phase of the response of about 1 week's duration is characterized by much higher numbers of PFC in the spleen and/or lymph nodes than in the BM. After the first week, on the other hand, the PFC response in the BM is substantially higher than in all other lymphoid organs together. A typical example of such a secondary response is given in Fig. 2. These characteristic kinetics are independent of the type of T-dependent antigen and the booster dose, and are found for IgM as well as IgG and IgA antibody production (Benner *et al.*, 1974b; Hill, 1976). Apparently, antibody formation is regulated in such a way that peripheral lymphoid tissues can respond rapidly, but show only a short-lasting response, whereas the BM responds slowly, but takes care of a long-lasting massive production of antibodies to antigens which repeatedly challenge the organism. The underlying mechanism of the long-lasting response in the bone marrow is unknown. The phenomenon might be due to a continuous recruitment of new PFC as well as to a long lifespan of the individual PFC. It would be of interest to

compare the mean lifespan of individual antibody-forming cells in the various lymphoid organs and the bone marrow.

For obvious reasons the human being is not normally accessible for studies on antibody formation in BM. However, some data are available about autoantibody production in various lymphoid tissues of patients suffering from rheumatoid arthritis and idiopathic thrombocytopenic purpura (ITP). In rheumatoid arthritis PFC producing rheumatoid factor are much more numerous in the BM than in the other lymphoid tissues (Vaughan *et al.*, 1976). Also, in chronic ITP the BM was found to be the major source of autoantibodies. In this disease the IgG anti-platelet antibody production in the BM was calculated to be 10-fold greater than that in the other lymphoid tissues (McMillan *et al.*, 1976).

THE MECHANISM UNDERLYING ANTIBODY FORMATION IN BONE MARROW

Studies on the mechanism underlying the appearance of antibody-forming cells in the BM have almost exclusively been done with mice. The key observations directing the experiments in this field are the weak PFC activity in the BM during the primary response to T-dependent antigens, and the high PFC response in this organ after secondary immunization with the same antigen (Benner *et al.*, 1974a; Hill, 1976). Several experiments revealed a coincidence between the occurrence of B and T memory cells and the capacity to respond to challenge with the relevant antigen with antibody formation in the BM (Benner & van Oudenaren, 1975; Benner, van Oudenaren & de Ruiter, 1977a). By priming and boosting of mice with various combinations of different hapten-carrier conjugates we recently showed that B memory cells, but not necessarily T memory cells, must be present before booster immunization for PFC to appear in the BM (Koch *et al.*, 1981a).

The origin of PFC which appear in the BM during secondary-type immune responses has been studied in parabiotic mice consisting of members congenic for the *Igh-1* locus. From analysis of the allotype of antibodies produced by PFC in the BM of such pairs of parabionts it appeared that antibody formation in the BM is dependent on the migration into the BM of B memory cells reactivated by antigen in peripheral lymphoid organs (Koch *et al.*, 1981a). After arrival in the BM these blast cells further mature into PFC, and produce large amounts of IgM, IgG and IgA antibodies (Benner, van Oudenaren & de Ruiter, 1977b; Koch, Weerheijm-de Wit & Benner, 1981b). This sequence of events is depicted in Fig. 3.

The migration of cells from the spleen into the BM takes place during the first few days of the secondary response, as can be concluded from experiments with mice splenectomized at different intervals after the booster injection. These experiments revealed that splenectomy 4 or more days after the booster injection does not influence the BM PFC response, whereas splenectomy on day 2

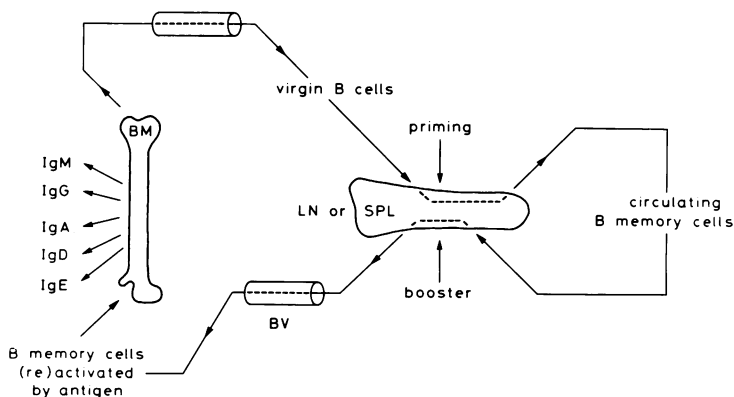

Fig. 3. Schematic representation of the mechanism underlying antibody formation in bone marrow. See text for explanation. BM = bone marrow; LN = lymph nodes; SPL = spleen; BV = blood vessel.

can completely prevent BM antibody formation (Benner *et al.*, 1977b). Consistent with such a migration of activated cells, radioautographic studies in guinea-pigs have demonstrated an influx of newly-formed mononuclear blast cells into the BM via the blood stream during the first 3 days after intravenous antigen administration (Koch *et al.*, 1981a). It is unclear yet why the blast cells leave the peripheral lymphoid organs, and what kind of factors are responsible for their accumulation in the BM.

The above line of evidence shows that antibody formation to T-dependent antigens in the BM, in contrast to peripheral lymphoid tissues, is dependent upon immigration of antigen-activated B lineage cells from elsewhere, instead of local induction of antibody formation. The reason probably is that the BM lacks the appropriate microenvironment and/or quantity or quality of cells (T lymphocytes? macrophages?) required for the earlier steps of induction of immune responses. This different constitution of BM and peripheral lymphoid organs might also be responsible for the long-lasting antibody formation in the BM, possibly due to a lack of feedback suppression of BM antibody formation.

In contrast to mouse BM, the human BM can display features which are characteristic for peripheral lymphoid tissues, e.g. the occurrence of follicles with germinal centres (Duhamel, 1968; Maeda, Hyun & Rebuck, 1977). Therefore, it is still an open question whether antibody formation in the human BM is similarly dependent upon an influx of antigen-activated B cells from the periphery as in mice.

Little is known about antibody formation in the BM in response to T-independent antigens. So far, antibody formation in the BM was investigated only after immunization with lipopolysaccharide and pneumococcal polysaccharide. Lipopolysaccharides and dinitrophenylated polysaccharides induce antibody formation in the BM of frog (Eipert *et al.*, 1979), mouse (Benner & van Oudenaren, 1976) and rabbit (Landy, Sanderson & Jackson, 1965). This result was found not only during secondary-type responses, but also during the primary response. Pneumococcal polysaccharide has been reported to be unable to induce antibody formation in the BM of mice (Baker *et al.*, 1971). It is unknown whether antibody formation in the BM to T-independent antigens is similarly dependent upon migration of antigen-activated B cells from peripheral lymphoid organs into the BM as antibody formation in the BM to T-dependent antigens.

Ig-secreting cells (Haaijman *et al.*, 1979; Benner *et al.*, 1981a) and antibody-producing cells (Benner, van Oudenaren & Haaijman, 1978; Benner & van Oudenaren, 1979) also occur in the BM of athymic nude mice. Just as normal mice, nude mice show an age-related shift of CIg cells towards the BM indicating that this shift is not dependent on the presence of the thymus. The number of CIg cells in the BM of 6- and 40-week-old nude mice is lower than in age-matched heterozygous littermates. On the other hand, in 2-year-old nude mice they are as high as in heterozygous mice of the same age, indicating a retarded development of the immunological activity in nude mice (Haaijman *et al.*, 1979). At all ages, CIg cells in nude mice are almost exclusively of the IgM class. After transplantation of thymus tissue under the kidney capsule of nude mice, the recovery of CIgG and CIgA cells in the BM starts later than in spleen (Haaijman *et al.*, 1980). This is compatible with the observations that for antibody formation in the BM, in contrast to peripheral lymphoid organs, B memory cells are required (Koch *et al.*, 1981a), and that the formation of B memory cells is amplified by T cells (Braley-Mullen, 1974).

The gradually increasing importance of the BM as a site of Ig synthesis throughout the lifespan (Fig. 1) probably reflects the gradual adaptations of the individual to its antigenic environment. As an individual becomes older, more antigenic stimuli from the environment will have been experienced and secondary-type responses will prevail. As outlined above, secondary-type responses to T-dependent antigens involve a quantitatively important antibody production in the BM.

We most sincerely thank Mr A. van Oudenaren, Dr G. Koch, Ms H. R. E. Schuit and Dr J. Radl for valuable discussions and important contributions throughout our studies on antibody formation in the bone marrow. Furthermore, we gratefully acknowledge Professor Dr O. Vos for his continuous support and interest, and Ms Cary Meijerink-Clerkx for typing the manuscript.

REFERENCES

- ASKONAS, B.A. & HUMPHREY, J.H. (1958) Formation of specific antibodies and γ -globulin. A study of the synthetic ability of various tissues from rabbits immunized by different methods. *Biochem. J.* **68**, 252.
- ASKONAS, B.A. & WHITE, R.G. (1956) Sites of antibody production in the guinea pig. The relation between *in vitro* synthesis of antiovalbumin and γ -globulin and distribution of antibody containing plasma cells. *Br. J. exp. Pathol.* **37**, 61.
- ASKONAS, B.A., WHITE, R.G. & WILKINSON, P.C. (1965) Production of γ_1 - and γ_2 -antiovalbumin by various lymphoid tissues of the guinea pig. *Immunochemistry*, **2**, 329.
- ASOFSKY, R. & THORBECKE, G.J. (1961) Sites of formation of immune globulins and of a component of C3. II. Production of immunoelectrophoretically identified serum proteins by human and monkey tissue *in vitro*. *J. exp. Med.* **114**, 471.
- BAKER, P.J., STASHAK, P.W., AMSBAUGH, D.F. & PRESCOTT, B. (1971) Characterisation of the antibody response to type III pneumococcal polysaccharide at the cellular level. I. Dose response studies and the effect of prior immunization on the magnitude of the antibody response. *Immunology*, **20**, 469.
- BENNER, R. & HAAIJMAN, J.J. (1980) Aging of the lymphoid system at the organ level. With special reference to the bone marrow as site of antibody production. *Dev. Comp. Immunol.* **4**, 591.
- BENNER, R., MEIMA, F., VAN DER MEULEN, G.M. & VAN MUISWINKEL, W.B. (1974a) Antibody formation in mouse bone marrow. I. Evidence for the development of plaque-forming cells *in situ*. *Immunology*, **26**, 247.
- BENNER, R., MEIMA, F., VAN DER MEULEN, G.M. & VAN EWIJK, W. (1974b) Antibody formation in mouse bone marrow. III. Effects of route of priming and antigen dose. *Immunology*, **27**, 747.
- BENNER, R., RIJNBEEK, A.-M., BERNABE, R.R., MARTINEZ-ALONSO, C. & COUTINHO, A. (1981a) Frequencies of background immunoglobulin-secreting cells in mice as a function of organ, age and immune status. *Immunobiology*, **158**, 225.
- BENNER, R. & VAN OUDENAREN, A. (1975) Antibody formation in mouse bone marrow. IV. The influence of splenectomy on the bone marrow plaque-forming cell response to sheep red blood cells. *Cell Immunol.* **19**, 167.
- BENNER, R. & VAN OUDENAREN, A. (1976) Antibody formation in mouse bone marrow. V. The response to the thymus-independent antigen *Escherichia coli* lipopolysaccharide. *Immunology*, **30**, 49.
- BENNER, R. & VAN OUDENAREN, A. (1979) Corticosteroids and the humoral immune response of mice. II. Enhancement of bone marrow antibody formation to lipopolysaccharide by high doses of corticosteroids. *Cell. Immunol.* **48**, 267.
- BENNER, R., VAN OUDENAREN, A. & DE RUITER, H. (1977a) Antibody formation in mouse bone marrow. VIII. Dependence on potentially circulating memory cells. A study with parabiotic mice. *Cell. Immunol.* **33**, 268.
- BENNER, R., VAN OUDENAREN, A. & DE RUITER, H. (1977b) Antibody formation in mouse bone marrow. IX. Peripheral lymphoid organs are involved in the initiation of bone marrow antibody formation. *Cell. Immunol.* **34**, 125.
- BENNER, R., VAN OUDENAREN, A. & HAAIJMAN, J.J. (1978) Deficient antibody formation in the bone marrow of nude mice. *Immunology*, **35**, 619.
- BENNER, R., VAN OUDENAREN, A. & KOCH, G. (1981b) Induction of antibody formation in mouse bone marrow. In *Immunological Methods* (ed. by I. Lefkovits and B. Pernis), Vol. II. Academic Press, New York.
- BRALEY-MULLEN, H. (1974) Regulatory role of T cells in IgG antibody formation and immune memory to type III pneumococcal polysaccharide. *J. Immunol.* **113**, 1909.
- CHAPERON, E.A., SELNER, J.C. & CLAMAN, H.N. (1968) Migration of antibody forming cells and antigen-sensitive precursors between spleen, thymus and bone marrow. *Immunology*, **14**, 553.
- DEUTSCH, L. (1899) Contribution à l'étude de l'origine des anticorps typhiques. *Ann. Inst. Pasteur*, **9**, 689.
- DUHAMEL, G. (1968) Les nodules lymphoïdes de la moelle osseuse. *Presse Medicale*, **76**, 1947.
- EIPERT, E.F., KLEMPAU, A.E., LALLONE, R.L. & COOPER, E.L. (1979) Bone marrow as a major lymphoid organ in *Rana*. *Cell. Immunol.* **46**, 275.
- GOLLAPUDI, V.S.S. & KIND, L.S. (1975) Phenotypic correction of low reagin production: a genetic defect in the SJL mouse. *J. Immunol.* **114**, 906.
- GRONOWICZ, E., COUTINHO, A. & MELCHERS, F. (1976) A plaque assay for all cells secreting Ig of a given type or class. *Eur. J. Immunol.* **6**, 588.
- HAAIJMAN, J.J. & HIJMANS, W. (1978) Influence of age on the immunological activity and capacity of the CBA mouse. *Mech. Ageing Dev.* **7**, 735.
- HAAIJMAN, J.J., SCHUIT, H.R.E. & HIJMANS, W. (1977) Immunoglobulin containing cells in different lymphoid organs of the CBA mouse during its lifespan. *Immunology*, **32**, 427.
- HAAIJMAN, J.J., SLINGERLAND-TEUNISSEN, J., BENNER, R. & VAN OUDENAREN, A. (1979) The distribution of cytoplasmic immunoglobulin containing cells over various lymphoid organs of congenitally athymic (nude) mice as a function of age. *Immunology*, **36**, 271.
- HAAIJMAN, J.J., SLINGERLAND-TEUNISSEN, J., VAN OUDENAREN, A., MINK, J.G. & BENNER, R. (1980) Kinetics of recovery of serum Ig levels and of cytoplasmic Ig positive cells in various lymphoid organs of nude mice after thymus transplantation. *Immunology*, **41**, 279.
- HALL, J.G., GYURE, L.A. & PAYNE, A.W.R. (1980) Comparative aspects of the transport of immunoglobulin A from blood to bile. *Immunology*, **41**, 899.
- HILL, S.W. (1976) Distribution of plaque-forming cells in the mouse for a protein antigen. Evidence for highly active parathymic lymph nodes following intraperitoneal injection of hen lysozyme. *Immunology*, **30**, 895.
- HIJMANS, W., SCHUIT, H.R.E. & HÜLSING-HESSELINK, E. (1971) An immunofluorescence study on intra-

- cellular immunoglobulins in human bone marrow. *Ann. N.Y. Acad. Sci.* **177**, 290.
- JANKOVIC, B.D., ISAKOVIC, K. & PETROVIC, S. (1973) Direct stimulation of lymphoid tissue of the chicken. III. Haemagglutinin production, haemolysin-forming cells and changes in lymphoid tissues following injection of guinea pig erythrocytes into the bone marrow. *Immunology*, **25**, 663.
- JANKOVIC, B.D. & PAUNOVIC, V.R. (1973) Immunological responses in the mole rat *Spalax leucodon*. *Ann. Immunol. (Paris)*, **124C**, 133.
- KIND, L.S. & MALLOY, W.F. (1974) Development of reaginic antibody-forming cells in the spleen and bone marrow of immunized mice. *J. Immunol.* **112**, 1609.
- KNOTHE, R., HERRLINGER, J.D. & MÜLLER-RUCHHOLTZ, W. (1979) B cell activity in rat bone marrow and spleen during primary and secondary response: dependence on strength of antigen. *Int. Arch. Allergy appl. Immunol.* **59**, 99.
- KOCH, G., OSMOND, D.G., JULIUS, M.H. & BENNER, R. (1981a) The mechanism of thymus-dependent antibody formation in bone marrow. *J. Immunol.* (In press.)
- KOCH, G., WEERHEIJM-DE WIT, C. & BENNER, R. (1981b) Quantitation of antibody production in the bone marrow during the secondary response to sheep erythrocytes. *Int. Arch. Allergy appl. Immunol.* (In press.)
- LANDY, M., SANDERSON, R.P. & JACKSON, A.L. (1965) Humoral and cellular aspects of the immune response to the somatic antigen of *Salmonella enteritidis*. *J. exp. Med.* **122**, 483.
- LÜDKE, H. (1912) Ueber Antikörperbildung in Kulturen lebender Körperzellen. *Berl. Klin. Wochenschr.* **49**, 1034.
- MAEDA, K., HYUN, B.H. & REBUCK, J.W. (1977) Lymphoid follicles in bone marrow aspirates. *Am. J. clin. Pathol.* **67**, 41.
- MCMILLAN, R., LONGMIRE, R.L., YELENOSKY, R., LANG, J.E., HEATH, V. & CRADDOCK, C.G. (1972) Immunoglobulin synthesis by human lymphoid tissues: normal bone marrow as a major site of IgG production. *J. Immunol.* **109**, 1386.
- MCMILLAN, R., YELENOSKY, R.J. & LONGMIRE, R.L. (1976) Antiplatelet antibody production by the spleen and bone marrow in immune thrombocytopenic purpura. In *Immuno Aspects of the Spleen* (ed. by J. R. Battisto and J. W. Streilein), p. 227. Elsevier, Amsterdam.
- MELLBYE, O.J. (1971) Antibody-producing cells in bone marrow and other lymphoid tissues during the primary immune response in mice. *Int. Arch. Allergy appl. Immunol.* **40**, 248.
- MORELL, A., SKVARIL, F., HIJMANS, W. & SCHERZ, R. (1975) Cytoplasmic immunofluorescence of bone marrow plasma cells producing immunoglobulins of the four IgG subclasses. *J. Immunol.* **115**, 579.
- ORLANS, E., PEPPARD, J., REYNOLDS, J. & HALL, J. (1978) Rapid active transport of immunoglobulin A from blood into bile. *J. exp. Med.* **147**, 588.
- PFEIFFER, R. & MARX (1898) Die Bildungsstätte der cholera Schutzstoffe. *Z. Hyg. Infektionskrankh.* **27**, 272.
- RADL, J., SCHUIT, H.R.E., MESTECKY, J. & HIJMANS, W. (1974) The origin of monomeric and polymeric forms of IgA in man. In *The Immunoglobulin A System* (ed. by J. Mestecky and A. R. Lawton), p. 57. Plenum, New York.
- REITER, H. (1913) Studien über Antikörper: Bildung *in vivo* und in Gewebskulturen. *Z. Immunitätsforsch.* **18**, 5.
- SKVARIL, F. & MORELL, A. (1974) Distribution of IgA subclasses in sera and bone marrow plasma cells of 21 normal individuals. In *The Immunoglobulin A System* (ed. by J. Mestecky and A. R. Lawton), p. 433. Plenum, New York.
- THEOFILOPOULOS, A.N., MCCONAHEY, P.J., IZUI, S., EISENBERG, R.A., PEREIRA, A.B. & CREIGHTON, W.D. (1980a) A comparative immunologic analysis of several murine strains with autoimmune manifestations. *Clin. Immunol. Immunopathol.* **15**, 258.
- THEOFILOPOULOS, A.N., SHAWLER, D.L., EISENBERG, R.A. & DIXON, F.J. (1980b) Splenic immunoglobulin-secreting cells and their regulation in autoimmune mice. *J. exp. Med.* **151**, 446.
- THORBECKE, G.J., ASOFKY, R.M., HOCHWALD, G.M. & SISKIND, G.W. (1962) Gamma globulin and antibody formation *in vitro*. III. Induction of secondary response at different intervals after the primary; the role of secondary nodules in preparation for the secondary response. *J. exp. Med.* **116**, 295.
- THORBECKE, G.J. & KEUNING, F.J. (1953) Antibody formation *in vitro* by haemopoietic organs after subcutaneous and intravenous immunization. *J. Immunol.* **70**, 129.
- THORBECKE, G.J. & KEUNING, F.J. (1956) Antibody and gamma globulin formation *in vitro* in haemopoietic organs. *J. infect. Dis.* **98**, 157.
- TURESSON, I. (1976) Distribution of immunoglobulin-containing cells in human bone marrow and lymphoid tissues. *Acta Med. Scand.* **199**, 293.
- VAN CAMP, B.G.K., SCHUIT, H.R.E., HIJMANS, W. & RADL, J. (1978) The cellular basis of double paraproteinaemia in man. *Clin. Immunol. Immunopathol.* **9**, 111.
- VAN FURTH, R., SCHUIT, H.R.E. & HIJMANS, W. (1966) The formation of immunoglobulins by human tissues *in vitro*. III. Spleen, lymph nodes, bone marrow and thymus. *Immunology*, **11**, 19.
- VAUGHAN, J.H., CHIHARA, T., MOORE, T.L., ROBBINS, D.L., TANIMOTO, K., JOHNSON, J.S. & MCMILLAN, R. (1976) Rheumatoid factor-producing cells detected by direct hemolytic plaque assay. *J. clin. Invest.* **58**, 933.
- VOSSEN, J.M. (1974) Age related development of humoral immunity in normal children and in children with immunodeficiencies. *Boll. Ist. Sieroter, Milan.* **53** (Suppl. 1), 152.