

# Not so ancient: the extant crown group of *Nothofagus* represents a post-Gondwanan radiation

Lyn G. Cook\* and Michael D. Crisp

*School of Botany and Zoology, The Australian National University, Canberra, ACT 0200, Australia*

This study uses a molecular-dating approach to test hypotheses about the biogeography of *Nothofagus*. The molecular modelling suggests that the present-day subgenera and species date from a radiation that most likely commenced between 55 and 40 Myr ago. This rules out the possibility of a reconciled all-vicariance hypothesis for the biogeography of extant *Nothofagus*. However, the molecular dates for divergences between Australasian and South American taxa are consistent with the rifting of Australia and South America from Antarctica. The molecular dates further suggest a dispersal of subgenera *Lophozonia* and *Fuscospora* between Australia and New Zealand after the onset of the Antarctic Circumpolar Current and west wind drift. It appears likely that the New Caledonian lineage of subgenus *Brassospora* diverged from the New Guinean lineage elsewhere, prior to colonizing New Caledonia.

The molecular approach strongly supports fossil-based estimates that *Nothofagus* diverged from the rest of Fagales more than 84 Myr ago. However, the mid-Cenozoic estimate for the diversification of the four extant subgenera conflicts with the palynological interpretation because pollen fossils, attributed to all four extant subgenera, were widespread across the Weddellian province of Gondwana about 71 Myr ago. The discrepancy between the pollen and molecular dates exists even when confidence intervals from several sources of error are taken into account. In contrast, the molecular age estimates are consistent with macrofossil dates. The incongruence between pollen fossils and molecular dates could be resolved if the early pollen types represent extinct lineages, with similar types later evolving independently in the extant lineages.

**Keywords:** biogeography; molecular dating; dispersal; vicariance; Gondwana; *Nothofagus*

## 1. INTRODUCTION

*Nothofagus*—southern beeches—have been the key group for understanding the distribution of plants and animals in the Southern Hemisphere for 150 years. (Raven 1996, p. vii)

*Nothofagus* has been regarded as a key group in southern biogeography because it was present and widespread in Gondwana before the super-continent broke up; it has been a dominant tree in rainforest communities through a long period of time and modern counterparts can be found for some of these fossil communities. Additionally, the genus has an abundant fossil record, especially pollen, that has tracked major shifts in climate and vegetation through the last 80 Myr (Darlington 1965; Van Steenis 1971; Humphries 1981; Dettmann *et al.* 1990; Hill & Dettmann 1996; Hill 2001). Therefore, much effort has gone into reconstructing its biogeography and the timing of radiation and extinction events through space and time. The phylogeny of the genus and its fagalean relatives has been investigated using extant and fossil morphology, and sequences of chloroplast DNA (cpDNA), nuclear region DNA (nrDNA) and mitochondrial DNA (mtDNA) (Humphries 1981; Hill & Jordan 1993; Martin & Dowd 1993; Linder & Crisp 1995; Manos 1997; Manos & Steele

1997; Jordan & Hill 1999; Li *et al.* 2004). From these studies, it is now reasonably clear that *Nothofagus* is monophyletic and sister to the rest of Fagales. The four extant subgenera (Hill & Read 1991) are monophyletic and related thus: (*Lophozonia* (*Fuscospora* (*Nothofagus*, *Brassospora*))). Except within *Brassospora*, the low-level relationships among the 35 extant species are reasonably well resolved and congruent among data sets.

In contrast, biogeographic analyses based on these phylogenies have yielded ambiguous results and conflicting interpretations. There has been controversy about the relative roles of vicariance, land-based dispersal before Gondwana broke up, and post-break-up dispersal across oceans (Humphries 1981; Pole 1994; Linder & Crisp 1995; Ladiges *et al.* 1997; Manos 1997; Swenson *et al.* 2001b; Sanmartín & Ronquist 2004).

The vicariance hypotheses (Linder & Crisp 1995; Swenson *et al.* 2001b) implicitly require that all four subgenera were widespread along the Weddell coast of Gondwana (Australia, Antarctica, New Zealand and southern South America) before break-up of this region occurred between 95 and 30 Myr ago (figure 1a), presumably by over-land dispersal during the late Cretaceous (e.g. Hill & Dettmann 1996). However, authors of cladistic-biogeographic analyses (Linder & Crisp 1995; Swenson *et al.* 2001b; Sanmartín & Ronquist 2004) have argued that the sister-group relationships between Australia and New Zealand in subgenera

\* Author for correspondence (lyn.cook@anu.edu.au).

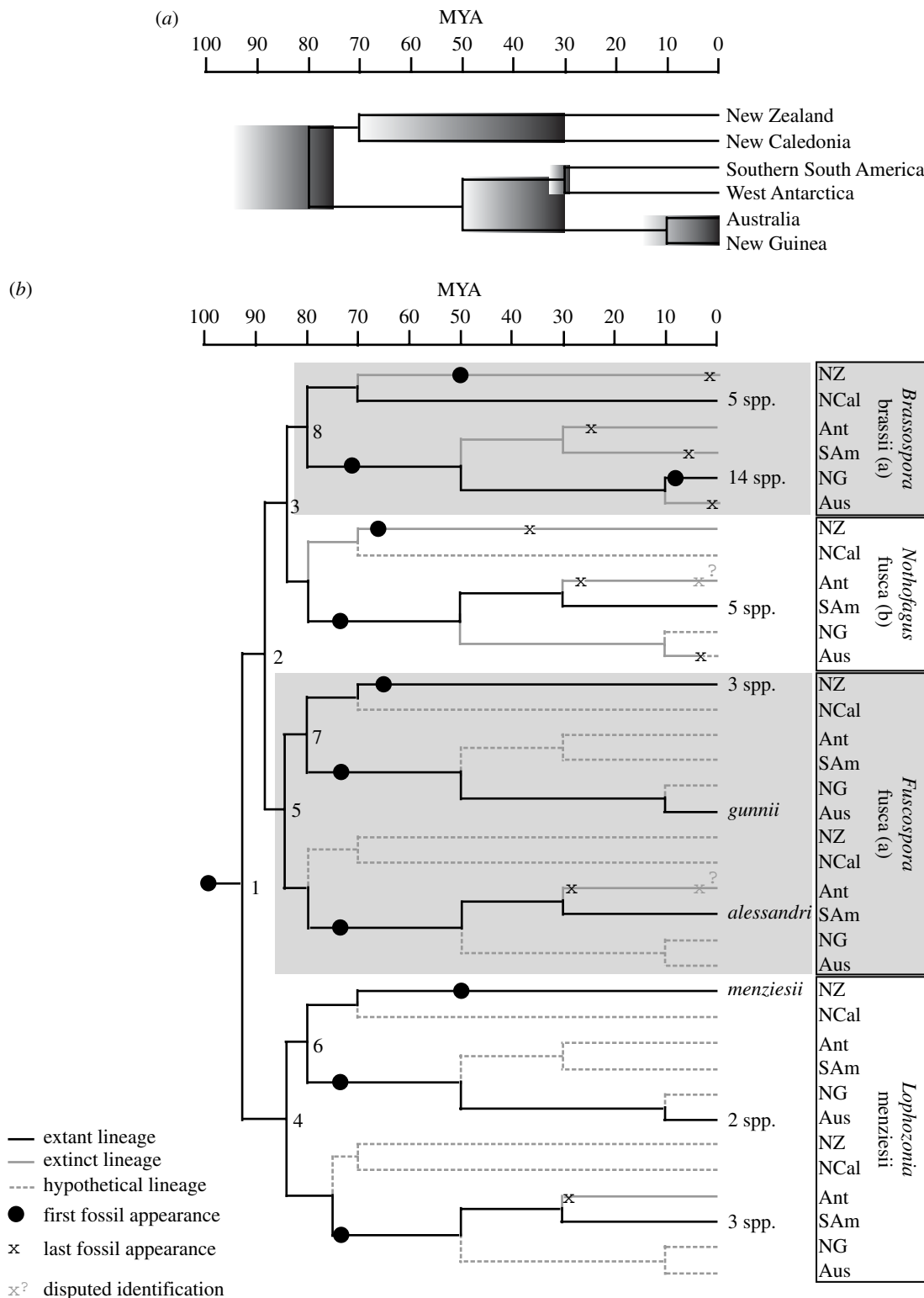

Figure 1. (a) Geological area cladogram, based on Sanmartín & Ronquist (2004). Shaded boxes indicate uncertainty in the timing of vicariance events. (b) Hypothetical reconciled tree, using the topology of Manos (1997, fig. 6), fitting the pattern and timing of divergence events to vicariance events in (a). This reconciliation allows no dispersal and implies multiple extinctions. Pollen types are shown and the current distribution of taxa is indicated. Nodes referred to in the text and in figure 3 are numbered 1–8.

*Lophozonia* and *Fuscospora* are incongruent with the pattern expected by a vicariance explanation. In both subgenera, the extant Australian and New Zealand species diverged more recently than their common ancestor diverged from the ancestor of the extant South American sister taxon (figure 1b). According to the conventional Gondwanan break-up hypothesis (figure 1a), Australia

and New Zealand should have separated by 80 Myr ago, well before Australia and South America split from Antarctica (between 50 and 30 Myr ago). Under this hypothesis, Australian taxa should be more closely related to South American taxa than to those from New Zealand.

The phylogenetic estimates for *Nothofagus* can be reconciled with a full vicariance scenario if the ages of

divergences are consistent with the timing of the break-up of eastern Gondwana, and if numerous extinctions are allowed (figure 1b). These are not unrealistic assumptions given that fossil pollen, interpreted as representing all four extant subgenera (Dettmann *et al.* 1990; Swenson *et al.* 2001b), indicates that Nothofagaceae was present at the break-up of eastern Gondwana (figure 1a,b). Additionally, the fossil record of *Nothofagus* suggests numerous extinctions across its range, including the loss of entire subgenera in Australia, New Zealand, South America and Antarctica (Hill 2001).

The timing of divergence events between extant taxa can be estimated indirectly using molecular rate modelling of phylogenies (Donoghue & Moore 2003; Sanderson 2003; Welch & Bromham 2005). If the speciation event is not contemporaneous with the timing of the hypothesized vicariance event then another process, such as long-distance dispersal, is more likely to be responsible for the disjunct distributions. To date, an all-vicariance hypothesis for *Nothofagus* biogeography has only been partially tested with molecular data. Using several representative taxa from Australia, New Zealand and South America, Knapp *et al.* (2005) determined that the estimated ages of divergence between Australian and New Zealand taxa were too recent to be the result of vicariance. However, Knapp *et al.* (2005) did not include outgroups and therefore did not address the age of the extant crown group of *Nothofagus*. Additionally, because they used fossil pollen ages to limit the age of the root of the extant *Nothofagus* crown group, they were unable to assess the fit of the fossil pollen record to the phylogeny.

Here we generate age estimates using the already available molecular data for *Nothofagus* and its relatives, calibrated by the most reliable fossils, to further test the hypothesis that the biogeography of extant *Nothofagus* is not the result of Weddell-region vicariance (figure 1b). For example, if the ages of the divergences between Australian and New Zealand taxa are confirmed to be younger than about 70 Myr, then vicariance under the standard geological model can be rejected as an explanation for their current distributions. Similarly, if the ages of divergences between the Australasian and South American taxa are significantly older or younger than the separation of Australia from Antarctica, then vicariance caused by that event can be rejected. In addition, we use the molecular data to assess the current idea that all four extant subgenera were present as early as 71 Myr ago (Dettmann *et al.* 1990; Hill 2001). This hypothesis predicts that the most recent divergence between subgenera, that between subgenera *Nothofagus* and *Brassopora*, should be older than 71 Myr.

## 2. MATERIAL AND METHODS

Sampling and analysis strategies aimed to take account of possible sources of error in molecular dating (e.g. Benton & Ayala 2003; Brochu *et al.* 2004; Graur & Martin 2004; Magallón 2004; Sanderson *et al.* 2004; Linder *et al.* 2005), including variation due to DNA region used, tree-topology estimation method, branch lengths, calibration points and rate smoothing. Additionally, we assessed variation due to crown-group sample size by performing taxon jack-knifing as described in electronic supplementary material, part C.

### (a) Phylogenetic estimation

Sequences for chloroplast regions *rbcl* (Martin & Dowd 1993), *matK* (Manos & Steele 1997) and the *atpB-rbcL* intergenic spacer (Setoguchi *et al.* 1997), and the nuclear region ITS/5.8S *rRNA* (Manos 1997), were obtained from GenBank for *Nothofagus* and its fagalean relatives, and for Cucurbitales and Fabales for use as outgroups. Rhamnaceae was used as the outgroup for *atpB-rbcL*. Accession numbers for sequences used are listed in electronic supplementary material, part G.

Data sets were checked for base compositional bias among taxa and for saturation. Multiple methods of tree estimation were used to obtain a set of trees with independently derived branch lengths and/or topologies. Analyses were run separately for each region and for a combined cpDNA data set (*atpB-rbcL* intergenic spacer + *rbcl*).

Bayesian analyses were conducted for each of the data sets using MrBayes v3.0.4b (Ronquist & Huelsenbeck 2003). A GTR+I+G model was used for each. The *rbcl* data set was partitioned by codon position with each assigned a GTR+I+G model that was unlinked across partitions. Multiple analyses were run for 3–5 million generations and checked for convergence. Trees saved during the burn-in period were discarded prior to further analysis. The 50% consensus tree with branch lengths was used as one of the input trees for molecular dating. An additional branch length set was derived for each Bayesian tree topology using a maximum likelihood model, with parameters estimated using MODELTEST (Posada & Crandall 1998).

Maximum parsimony (MP) trees were obtained in PAUP\* (Swofford 2002) using 100 random addition starting sequences, TBR and saving only 10 trees per replicate. The set of trees obtained was then searched to completion. One of the MP phylograms was then chosen randomly for use in dating analysis.

Maximum likelihood (ML) trees were obtained for smaller data sets (*Nothofagus*-only ITS/5.8S *rRNA*; cpDNA; *atpB-rbcL* spacer) using heuristic searches from 10 random-addition starting trees and parameters estimated using MODELTEST. The *Nothofagus*-only ITS/5.8S *rRNA* tree was midpoint-rooted. We used the minimum evolution criterion (ME) and a ML model, with parameters derived from MODELTEST, for *rbcl* and *matK*.

A LogDet correction (Lockhart *et al.* 1994) of molecular evolution was used for analyses of the full ITS/5.8S *rRNA* data because non-stationarity was detected between *Nothofagus* and outgroups.

### (b) Molecular rate modelling and dating of nodes

All data sets violated the assumption of a molecular clock, as assessed using PAUP\* to determine likelihood scores for trees derived with and without a molecular clock enforced. Therefore we used both non-parametric rate smoothing (NPRS) and penalized likelihood (PL) methods, as implemented in r8s (Sanderson 2003), to estimate ages and confidence intervals for nodes of interest. Cross-validation tests were performed to determine optimal smoothing parameter values for use in penalized likelihood analyses. However, we also explored a range of smoothing parameter values to assess how choice of value affected the estimated age of nodes.

#### (i) Confidence intervals

We generated 100 bootstrapped data sets using PHYLIP (Felsenstein 2004) for both *rbcl* and combined cpDNA. The

Table 1. Fossil calibration points (ages in Myr).

node	fossil	age	references
fixed root: Fagales stem base (=Fagales-Cucurbitales split)	<i>Normapolles</i>	96	Pacltová (1966), cited in Magallón & Sanderson (2001)
<i>Nothofagus</i> stem base (=Fagales crown, FagC)	'ancestral' pollen type	84	Dettmann (1994)
crown of sister group of <i>Nothofagus</i> (NSC)	<i>Protofagacea</i> , <i>Antiquicupula</i> , <i>Bedellia</i> , <i>Caryanthus</i> , <i>Normapolles</i> flower A	84	Herendeen <i>et al.</i> (1999)
Betulaceae + Casuarinaceae stem (BCS)	<i>Endressianthus</i>	71	Friis <i>et al.</i> (2003)
Casuarinaceae crown ( <i>CasC</i> )	<i>Gymnostoma antiquum</i>	55	Scriven & Hill (1995)
Coryloideae crown ( <i>CoryC</i> )	<i>Corylus</i> and <i>Carpinus</i>	50	Pigg <i>et al.</i> (2003)
<i>Nothofagus</i> crown (node 1; <i>NotC</i> )	<i>N. tasmanica</i>	45	Hill (2001)
<i>Fagus</i> : alternately stem and crown ( <i>FagusS</i> ; <i>FagusC</i> )	cupules and nuts	45	Denk (2003)
<i>Nothofagus</i> subgenera <i>Fuscospora</i> , <i>Nothofagus</i> and <i>Brassospora</i> : common crown (Node 2; <i>FNBC</i> )	<i>N. cethanica</i> , <i>N. gunnii</i> , <i>N. lobata</i> , <i>N. mucronata</i> , <i>N. serrata</i>	34	Hill (2001)

tree topology was then constrained to the ML tree (combined cpDNA) or MrBayes consensus tree (*rbcL*) derived from unpermuted data and branch lengths were estimated using each bootstrap matrix, with ML parameters obtained using MODELTEST. The resultant 100 phylograms were input to r8s to obtain statistics for nodes, using the 'profile' command.

### (c) Calibration points

Multiple calibration points were used, each supported by one or more dated fossils (table 1; justification in electronic supplementary material, part B). In most analyses, the root was fixed at a divergence between Fagales and Cucurbitales (fossil = *Normapolles*) of 96 Myr. In data sets that lacked suitable outgroups for this node (ITS/5.8S *rRNA*, *atpB-rbcL* spacer, cpDNA), the crown of Fagales (= *Nothofagus* stem) was fixed at 89 Myr ago. This latter age was derived from molecular estimates based on *rbcL* (this study), and is older than the first appearance of fossils for taxa on both sides of the basal node (84 Myr ago). We performed analyses without internal constraints, or with varying combinations of internal constraints, to assess the fit of the fossil estimates to the molecular dating and to determine whether different combinations affected age estimates. Where fossil placement on the phylogeny was uncertain, the effects of alternative positions were compared.

## 3. RESULTS

Phylogenetic topologies (e.g. figure 2) were generally congruent among genes and with those published previously (e.g. figure 1). There were three relevant differences in topology among partitions. Neither the South American nor Australian species of subgenus *Lophozonia* formed monophyletic groups in analyses of *rbcL* (except under ME), whereas each was monophyletic in analyses of cpDNA, *atpB-rbcL* spacer and ITS/5.8S *rRNA*. Subgenus *Nothofagus* was not monophyletic in analyses of the *atpB-rbcL* spacer.

Saturation was detected at deeper divergences within all data sets indicating that the use of corrective models, such as GTR+I+G, for estimating branch lengths was preferable over MP. No evidence of saturation was detected within the crown group of *Nothofagus*.

### (a) Fit of calibration points

Using only the 96 Myr constraint for the divergence between Fagales and Cucurbitales, estimates of ages outside *Nothofagus* were generally consistent with the calibration points tested (electronic supplementary material, part E), especially when calibration points represented macrofossils. The unconstrained range of age estimates for the Fagales crown (=base of the *Nothofagus* stem) (75–95 Myr ago, including all point estimates and the 95% bootstrap interval) encompassed the 84 Myr old fossils of *Nothofagus* and several other *Fagales*. Estimated dates for the Betulaceae–Casuarinaceae stem-base were consistent with the fossil record, most being older than the minimum 71 Myr ago calibration point, and up to 81 Myr ago. The *Fagus* stem-base was estimated to be considerably older (67–77 Myr ago) than the minimum-age calibration point of 45 Myr ago. Varying the combinations of the above minimum constraints did not affect age estimates within *Nothofagus*.

Age estimates within *Nothofagus* were remarkably consistent among DNA regions when the crown group was well sampled. Estimated dates for the *Nothofagus* crown (figure 3) generally fell close to, or encompassed, the oldest definite macrofossil for the genus (45 Myr old). Similarly, estimated dates were consistent with the macrofossil evidence for the separation of subgenera *Nothofagus* and *Brassospora* (34 Myr ago). Consequently, when these two dates were used as constraints, they had a significant effect only when unconstrained dates were younger than the fossil-based minimum age, as occurred in analyses of *matK* and under some rate smoothing values in the other data sets. This is because age estimates were forced back in time to the older fossil-based estimates. Analyses of *matK* (electronic supplementary material, part D) gave consistently much younger estimates for divergences within *Nothofagus* than did other DNA regions (but see comments on sample size below). Dates estimated from this gene for other Fagales divergences were generally consistent with the fossil calibration points.

### (b) Variation among age estimates

Two variables—PL smoothing parameter value and crown-group sample size—were the major contributors

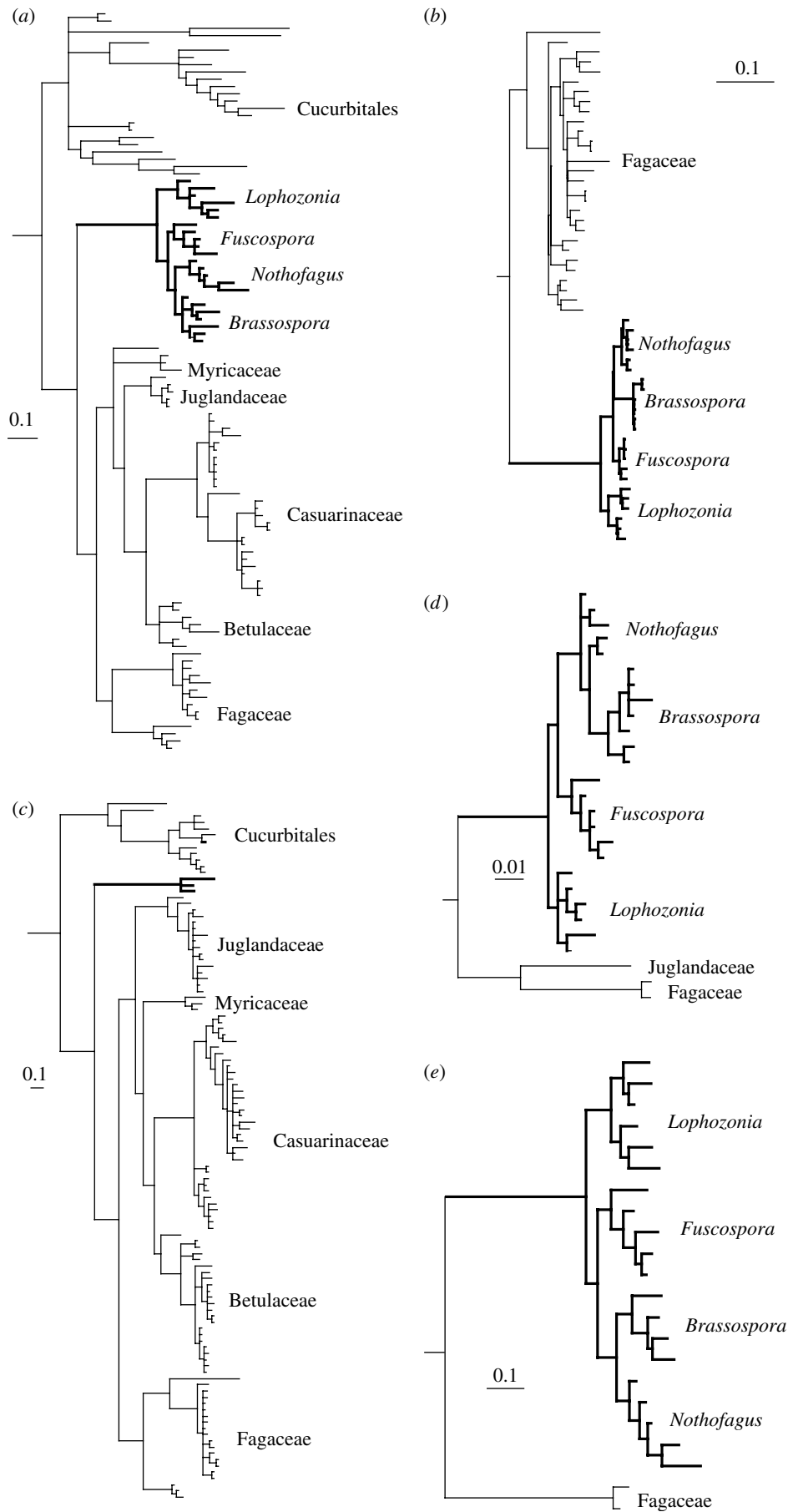

Figure 2. Phylograms showing long stem and short crown for *Nothofagus* in all DNA regions analysed. *Nothofagus* is highlighted by bold lines and subgenera are labelled. Bayesian consensus phylograms (a) *rbcL*, (c) *matK*, (d) *atpB-rbcL* intergenic spacer, (e) combined cpDNA of *rbcL* and *atpB-rbcL* intergenic spacer. (b) LogDet distance phylogram of ITS/5.8S *rDNA*.

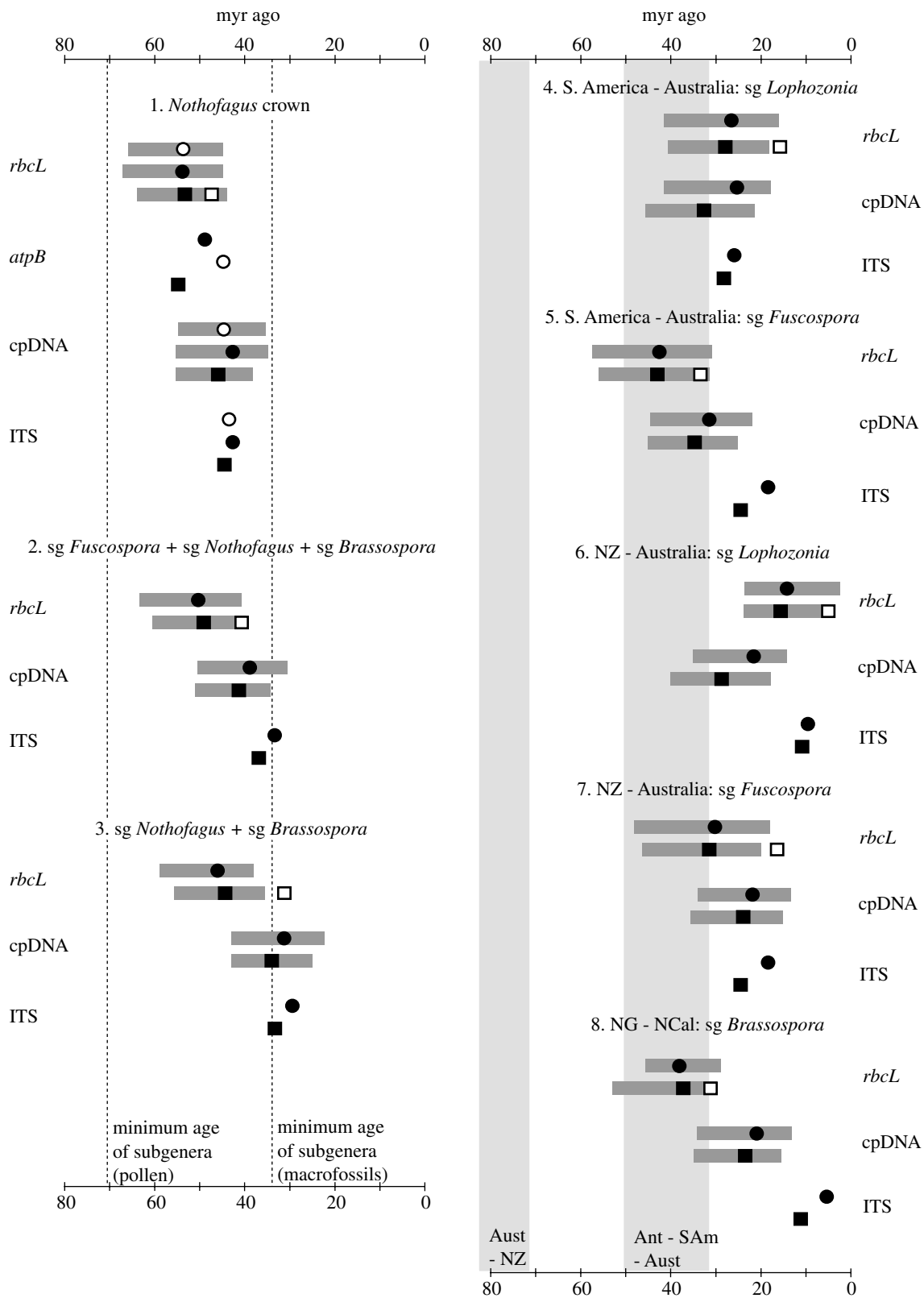

Figure 3. Estimated ages of nodes within *Nothofagus* (numbered as in figure 1b; sg, subgenus), showing variation according to molecular data source (as labelled: cpDNA, combined *rbcL* gene and *atpB-rbcL* spacer) and date estimation method (filled square, non-parametric rate smoothing (NPRS); open square, NPRS with *rbcL* third position only; filled circle, penalized likelihood (PL), with best smoothing parameter value; open circle, PL with second best value). Horizontal grey bars indicate 95% bootstrap confidence intervals. Vertical lighter grey bars indicate vicariance events as in figure 1 (Ant, Antarctica; Aust, Australia; NZ, New Zealand; SAM, South America).

to variation in age estimates (figure 3 and electronic supplementary material, parts C–D). There was variation among DNA regions but, in general, the above two factors produced as much, or more, variation among analyses of

the one DNA region than was found between regions. In general, analyses of *rbcL* gave older point estimates for most nodes than those of other data sets (figure 3). Analyses of the third codon positions of *rbcL* gave younger

ages than did the full data set (figure 3). Third codon positions were analysed separately because evidence of saturation and non-phylogenetic signal was detected for first and second codon positions (see electronic supplementary material, part F).

A very large sample-size effect was detected in two taxon jack-knife analyses (electronic supplementary material, part C). In both analyses, small crown-group sizes gave younger dates than the equivalent full data set and the fewer the taxa, the greater the discrepancy. In both analyses, however, estimates with several taxa removed were equivalent to those of the full data set, suggesting that the real data were sufficiently sampled to avoid the effect of small sample-size. The apparent sample-size effect is relevant to the *matK* analyses, in which *Nothofagus* was represented by only three species. The *Nothofagus* crown group appeared much younger using this DNA region (electronic supplementary material, part D) than in the better-sampled *rbcL*, *atpB-rbcL* spacer, ITS/5.8S *rRNA* and combined cpDNA data sets.

The optimal smoothing parameter, as determined by cross-validation tests, differed among data sets but was usually in the range of 3–30. Trials with higher, non-optimal values generally returned younger estimates of ages within *Nothofagus* (electronic supplementary material, part D).

#### (c) Age of *Nothofagus* crown and subgenera

In phylograms derived from each of the DNA regions, and under all tree estimation methods, *Nothofagus* has a long stem subtending the crown group (figure 2). This stem represents the sole lineage from which extant species of *Nothofagus* are derived. Unconstrained point estimates for the age of the basal divergence among extant *Nothofagus* ranged from a maximum age of 58 Myr ago to a minimum age of 21 Myr ago (node 1, figure 3). The 95% bootstrap confidence intervals ranged from 66 to 45 Myr ago for *rbcL*, and from 56 to 34 Myr ago for the combined cpDNA data. These confidence intervals encompass the estimated ages derived from all DNA regions used, except *matK*.

Node 3 (subgenera *Nothofagus* + *Brassospora*) represents the earliest point at which all four extant subgenera coexisted. Bootstrap 95% confidence intervals for this node range from 58 to 36 Myr ago (*rbcL*) and 43 to 23 Myr ago (cpDNA), which encompass all point estimates from DNA regions that included this node.

#### (d) Biogeography

Point estimates of the divergence times between New Zealand and Australian species in *Lophozonia* (node 6; 49–5 Myr ago) overlap those within *Fuscospora* (node 7; 37–3 Myr ago) (figure 3). Confidence intervals derived from the bootstrapped cpDNA data set were 40–14 and 37–13 Myr ago, respectively. Analyses of the cpDNA data gave estimates for the three Australasia/South America splits (nodes 3, 4 and 5) of about 30 Myr (figure 3). Those of the *rbcL* data estimated the split in *Brassospora/Nothofagus* and in *Fuscospora* (nodes 3 and 5, respectively) at about 45 Myr ago whereas that within *Lophozonia* (node 4) was estimated at about 30 Myr ago. New Caledonian and New Guinean taxa of subgenus *Brassospora* were estimated to have diverged between 42 and 3 Myr ago (node 8, figure 3).

## 4. DISCUSSION

### (a) Implications for biogeography

The molecular estimates for the origin of Nothofagaceae are remarkably consistent with the fossil record: *Nothofagidites* pollen first appeared in southern Australia and Antarctica 83.5 Myr ago (Dettmann *et al.* 1990), and the first macrofossil records of its sister group, from the Northern Hemisphere, are the same age (Herendeen *et al.* 1999). Thus, molecular modelling, in conjunction with the fossil record, suggests that Nothofagaceae diverged from the rest of Fagales between 93 and 83.5 Myr ago. This was before the landmasses to which it appears to have always been restricted (Antarctica, Australia, New Zealand, New Caledonia, New Guinea and South America) rifted apart.

The all-vicariance scenario presented in figure 1b can be rejected because the radiation of the crown group of *Nothofagus* was too recent. In particular, the independent divergences between Australian and New Zealand taxa in subgenera *Lophozonia* (node 6) and *Fuscospora* (node 7) occurred less than 50 Myr ago, and possibly much more recently (figure 3). This is more than 30 Myr after the opening of the Tasman Sea (figure 1a) and is consistent with the ages estimated by Knapp *et al.* (2005), despite their use of a different calibration system. Thus, it appears that *Nothofagus* is not vicariant across the Tasman Sea. As suggested by Knapp *et al.* (2005), the molecular data indicate that earlier populations of *Nothofagus* in New Zealand (McGlone *et al.* 1996, electronic supplementary material, part A) became extinct, with *Nothofagus* now represented only by more recent arrivals.

The timings of the divergence between Australasian and South American taxa in each of subgenera *Lophozonia* and *Fuscospora*, and between subgenera *Nothofagus* and *Brassospora*, coincide well with the hypothesized rifting events that split Australia, Antarctica and South America between 50 and 30 Myr ago (figure 3). Thus, three of the earliest divergences within the *Nothofagus* crown are consistent with the vicariance of Australia and South America. The results suggest that there were at least three taxa (currently represented by *Lophozonia*, *Fuscospora* and *Nothofagus/Brassospora*) present across the Weddell region of Gondwana at the time Australia and South America separated.

The divergence between New Caledonian and New Guinean taxa (basal split in *Brassospora*; node 8) is too young for the hypothesized 70 Myr vicariance of New Caledonia (Swenson *et al.* 2001a) and older than the pollen evidence. The *Nothofagus* pollen record in New Guinea begins about 12 Myr ago but that in New Caledonia dates only from about 2 Myr ago (Dettmann *et al.* 1990). The divergence between the New Guinea and New Caledonian taxa may have occurred elsewhere, as suggested by Swenson *et al.* (2001a), because the molecular dates are too old for the New Caledonian radiation to have occurred from recently arrived (less than 2 Myr ago) migrants from New Guinea. However, the fossil record for New Caledonia is poorly known (Dettmann *et al.* 1990) and it is possible that the extant lineage arrived prior to 2 Myr ago. Although it has been suggested that the New Caledonian taxon may have dispersed along the Lord Howe Rise from New Zealand (Swenson *et al.* 2001a), it is also possible that it dispersed from Australia. *Brassospora* macrofossils of the right age

(29–34 Myr) are known from Australia and pollen of the subgenus was present in Australia up to about 2 Myr ago (Hill 2001).

*Nothofagus* has not been considered very dispersible (Crisci *et al.* 2003) but both the pattern and timing of divergence events indicate that dispersal has played a major role in the current biogeography of the genus. The molecular dates for the divergence between Australian and New Zealand taxa are consistent with a dispersal role for west wind drift, which was initiated in conjunction with the Antarctic Circumpolar Current after the separation of Australia and South America from Antarctica about 31 Myr ago (Florindo *et al.* 2003; Lawver & Gahagan 2003).

#### (b) Radiation of *Nothofagus* and its subgenera

The molecular dates for the radiation of the extant *Nothofagus* lineage are younger than direct estimates from the fossil pollen record. Pollen attributed to all four subgenera has been recognized from 71 to 73 Myr ago (figure 1b; electronic supplementary material, part A) (Dettmann *et al.* 1990; Swenson *et al.* 2001b). The earliest node in the *Nothofagus* phylogeny from which all four extant subgenera coexisted was estimated to be no more than 58 Myr old (upper 95% confidence limit, *rbcL*), with point estimates from other DNA regions being at least 15 Myr more recent. Therefore, there is a minimum discrepancy of 13 Myr between fossil and molecular estimates of the age of the subgenera. Even confidence intervals for the basal node in the *Nothofagus* crown (node 1) do not extend to dates old enough to encompass the 71 Myr old pollen. In order to reconcile the molecular dates with a fossil pollen age of 71 Myr for all extant subgenera, the base of the stem of Fagales would need to be pulled back to an age of at least 150 Myr if point estimates for the subgenera *Nothofagus/Brassospora* divergence were to fit. This age seems unlikely given current age estimates for angiosperms, eudicots and rosids (Sanderson & Doyle 2001; Wikström *et al.* 2003; Chaw *et al.* 2004; Sanderson *et al.* 2004).

Whilst the incongruence between molecular and pollen fossil dates may indicate error in the molecular dating, it also calls into question the interpretation of the fossil pollen. It suggests that at least some of the old pollen types that have been identified to extant subgenera do not belong to the crown group. If the molecular dating is correct, only one of the four pollen types recognized in the fossil record of 71–73 Myr could belong to the extant lineage of *Nothofagus*, unless it were polymorphic within species, because this lineage was reduced to a single taxon before it radiated into the four extant subgenera more recently than 58 Myr ago. Therefore, similar pollen types have probably evolved convergently in different lineages at different times and most of the older fossil types represent extinct lineages, as previously suggested for the ‘ancestral’ and ‘brassi’ (a) and (b) types (Hill 2001).

Phylograms of *Nothofagus* (figure 2) have a ‘broom and handle’ shape (Crisp *et al.* 2004), with a number of lineages arising in a relatively short period (the broom) at the end of a long stem (the handle). The long naked ‘broom handle’ indicates that only a single lineage of *Nothofagus* survived from its origin about 89 Myr ago until the present. The molecular estimates for the diversification of the extant crown group about 55–35 Myr ago

reflect the fossil record, which shows a global increase in *Nothofagus* species diversity from the late Eocene to a historical maximum in the late Oligocene to early Miocene (Hill 2001). Ironically, the younger dates estimated by the molecular modelling coincide with radiations in sclerophyll taxa such as *Banksia*, eucalypts and Casuarinaceae (Crisp *et al.* 2004). Extant lineages of *Nothofagus*, traditionally considered to be ancient relicts of a prior warm and wet environment, may represent a radiation in response to the same climatic changes that are thought to have allowed radiations in groups thought of as ‘recent’.

## 5. CONCLUSIONS

Both vicariance and dispersal have clearly played a role in the current distributional patterns of *Nothofagus*. The molecular modelling presented here is consistent with the macrofossil record of *Nothofagus*, but is contrary to some interpretations of the older palynological data. Corroboration from additional nuclear genes is required, however, because of the apparent inherent problems associated with the ITS/5.8S *rRNA* region.

This project was funded by an Australian Research Council Discovery Grant to MDC. We thank Geoff Hope, Mike Macphail, Matt Morgan, Liz Truswell and the Coopers and Cladistics discussion group for helpful suggestions. We would like to thank three anonymous referees for their useful comments on the manuscript.

## REFERENCES

- Benton, M. J. & Ayala, F. J. 2003 Dating the tree of life. *Science* **300**, 1698–1700. (doi:10.1126/science.1077795.)
- Brochu, C. A., Sumrall, C. D. & Theodor, J. M. 2004 When clocks (and communities) collide: estimating divergence time from molecules and the fossil record. *J. Paleontol.* **78**, 1–6.
- Chaw, S. M., Chang, C. C., Chen, H. L. & Li, W. H. 2004 Dating the monocot–dicot divergence and the origin of core eudicots using whole chloroplast genomes. *J. Mol. Evol.* **58**, 424–441. (doi:10.1007/s00239-003-2564-9.)
- Crisci, J. V., Katinas, L. & Posadas, P. 2003 *Historical biogeography: an introduction*. Cambridge: Harvard University Press.
- Crisp, M. D., Cook, L. G. & Steane, D. A. 2004 Radiation of the Australian flora: what can comparisons of molecular phylogenies across multiple taxa tell us about the evolution of diversity in present-day communities?. *Philos. Trans. R. Soc. B* **359**, 1551–1571. (doi:10.1098/rstb.2004.1528.)
- Darlington, P. J. 1965 *Biogeography of the southern end of the world*. Cambridge, MA: Harvard University Press.
- Denk, T. 2003 Phylogeny of *Fagus* L. (Fagaceae) based on morphological data. *Plant Syst. Evol.* **240**, 55–81. (doi:10.1007/s00606-003-0018-x.)
- Dettmann, M. E. 1994 Cretaceous vegetation: the microfossil record. In *History of the Australian vegetation: Cretaceous to Recent* (ed. R. S. Hill), pp. 143–170. Cambridge, UK: Cambridge University Press.
- Dettmann, M. E., Pocknall, D. T., Romero, E. J. & Carmen Zamalao, M. D. 1990 *Nothofagidites Erdtman ex Potonie*, 1960; a catalogue of species with notes on the palaeogeographic distribution of *Nothofagus* Bl. (Southern Beech). *N Z Geol. Survey Paleontol. Bull.* **60**, 1–79.
- Donoghue, M. J. & Moore, B. R. 2003 Toward an integrative historical biogeography. *Integr. Comp. Biol.* **43**, 261–270.
- Felsenstein, J. 2004 PHYLIP: phylogeny inference package, version 3.6. Seattle: University of Washington.



- Florindo, F., Cooper, A. K. & O'Brien, P. E. 2003 Introduction to Antarctic Cenozoic palaeoenvironments: geologic record and models. *Palaeogeogr. Palaeoclimatol. Palaeoecol.* **198**, 1–9. (doi:10.1016/S0031-0182(03)00405-X.)
- Friis, E. M., Pedersen, K. R. & Schonenberger, J. 2003 *Endressianthus*, a new *Normapolles*-producing plant genus of fagalean affinity from the Late Cretaceous of Portugal. *Int. J. Plant Sci.* **164**, S201–S223. (doi:10.1086/376875.)
- Graur, D. & Martin, W. 2004 Reading the entrails of chickens: molecular timescales of evolution and the illusion of precision. *Trends Genet.* **20**, 80–86. (doi:10.1016/j.tig.2003.12.003.)
- Herendeen, P. S., Magallon-Puebla, S., Lupia, R., Crane, P. R. & Kobylinska, J. 1999 A preliminary conspectus of the Allon flora from the Late Cretaceous (late Santonian) of central Georgia, USA. *Ann. Missouri Bot. Garden* **86**, 407–471.
- Hill, R. S. 2001 Biogeography, evolution and palaeoecology of *Nothofagus* (Nothofagaceae): the contribution of the fossil record. *Aust. J. Bot.* **49**, 321–332. (doi:10.1071/BT00026.)
- Hill, R. S. & Dettmann, M. E. 1996 Origin and diversification of the genus *Nothofagus*. In *The ecology and biogeography of Nothofagus forests* (ed. T. T. Veblen, R. S. Hill & J. Read), pp. 11–24. London: Yale University Press.
- Hill, R. S. & Jordan, G. J. 1993 The evolutionary history of *Nothofagus* (Nothofagaceae). *Aust. Syst. Bot.* **6**, 111–126. (doi:10.1071/SB9930111.)
- Hill, R. S. & Read, J. 1991 A revised infrageneric classification of *Nothofagus* (Fagaceae). *Bot. J. Linn. Soc.* **105**, 37–72.
- Humphries, C. J. 1981 Biogeographical methods and the southern beeches (Fagaceae: *Nothofagus*). In *Advances in cladistics* (ed. V. A. Funk & D. R. Brooks), pp. 177–207. New York: The New York Botanical Garden.
- Jordan, G. J. & Hill, R. S. 1999 The phylogenetic affinities of *Nothofagus* (Nothofagaceae) leaf fossils based on combined molecular and morphological data. *Int. J. Plant Sci.* **160**, 1177–1188. (doi:10.1086/314207.)
- Knapp, M., Stöckler, K., Havell, D., Delsuc, F., Sebastiani, F. & Lockhart, P. J. 2005 Relaxed molecular clock provides evidence for long-distance dispersal of *Nothofagus* (Southern Beech). *PLoS Biol.* **3**, 38–43. (doi:10.1371/journal.pbio.0030014.)
- Ladiges, P. Y., Nelson, G. & Grimes, J. 1997 Subtree analysis, *Nothofagus*, and Pacific biogeography. *Cladistics* **13**, 125–129.
- Lawver, L. A. & Gahagan, L. M. 2003 Evolution of Cenozoic seaways in the circum-Antarctic region. *Palaeogeogr. Palaeoclimatol. Palaeoecol.* **198**, 11–37. (doi:10.1016/S0031-0182(03)00392-4.)
- Li, R. Q., Chen, Z. D., Lu, A. M., Soltis, D. E., Soltis, P. S. & Manos, P. S. 2004 Phylogenetic relationships in Fagales based on DNA sequences from three genomes. *Int. J. Plant Sci.* **165**, 311–324. (doi:10.1086/381920.)
- Linder, H. P. & Crisp, M. D. 1995 *Nothofagus* and Pacific biogeography. *Cladistics* **11**, 5–32. (doi:10.1111/j.1096-0031.1995.tb00002.x.)
- Linder, H. P., Hardy, C. R. & Rutschmann, F. 2005 Taxon sampling effects in molecular clock dating: an example from the African Restionaceae. *Mol. Phylog. Evol.* **35**, 569–582. (doi:10.1016/j.ympev.2004.12.006.)
- Lockhart, P. J., Steel, M. A., Hendy, M. D. & Penny, D. 1994 Recovering evolutionary trees under a more realistic model of sequence evolution. *Mol. Biol. Evol.* **11**, 605–612.
- Magallón, S. & Sanderson, M. J. 2001 Absolute diversification rates in angiosperm clades. *Evolution* **55**, 1762–1780.
- Magallón, S. A. 2004 Dating lineages: molecular and paleontological approaches to the temporal framework of clades. *Int. J. Plant Sci.* **165**, S7–S21.
- Manos, P. S. 1997 Systematics of *Nothofagus* (Nothofagaceae) based on rDNA spacer sequences (ITS): taxonomic congruence with morphology and plastid sequences. *Am. J. Bot.* **84**, 1137–1155.
- Manos, P. S. & Steele, K. P. 1997 Phylogenetic analyses of higher Hamamelididae based on plastid sequence data. *Am. J. Bot.* **84**, 1407–1419.
- Martin, P. G. & Dowd, J. M. 1993 Using sequences of *rbcL* to study phylogeny and biogeography of *Nothofagus* species. *Aust. Syst. Bot.* **6**, 441–447. (doi:10.1071/SB9930441.)
- McGlone, M. S., Mildenhall, D. C. & Pole, M. S. 1996 History and paleoecology of New Zealand *Nothofagus* forests. In *The ecology and biogeography of Nothofagus forests* (ed. T. T. Veblen, R. S. Hill & J. Read), pp. 83–130. New Haven and London: Yale University Press.
- Pigg, K. B., Manchester, S. R. & Wehr, W. C. 2003 *Corylus*, *Carpinus*, and *Palaeocarpinus* (Betulaceae) from the middle Eocene Klondike Mountain and Allenby formations of northwestern North America. *Int. J. Plant Sci.* **164**, 807–822. (doi:10.1086/376816.)
- Pole, M. 1994 The New Zealand flora—entirely long-distance dispersal? *J. Biogeogr.* **21**, 625–635.
- Posada, D. & Crandall, K. A. 1998 MODELTEST: testing the model of DNA substitution. *Bioinformatics* **14**, 817–818. (doi:10.1093/bioinformatics/14.9.817.)
- Raven, P. 1996 Preface. In *The ecology and biogeography of Nothofagus forests* (ed. T. T. Veblen, R. S. Hill & J. Read), p. vii. New Haven, CT: Yale University Press.
- Ronquist, F. & Huelsenbeck, J. P. 2003 MrBayes 3: Bayesian phylogenetic inference under mixed models. *Bioinformatics* **19**, 1572–1574. (doi:10.1093/bioinformatics/btg180.)
- Sanderson, M. J. 2003 R8s: inferring absolute rates of molecular evolution and divergence times in the absence of a molecular clock. *Bioinformatics* **19**, 301–302. (doi:10.1093/bioinformatics/19.2.301.)
- Sanderson, M. J. & Doyle, J. A. 2001 Sources of error and confidence intervals in estimating the age of angiosperms from *rbcL* and 18S rDNA data. *Am. J. Bot.* **88**, 1499–1516.
- Sanderson, M. J., Thorne, J. L., Wikström, N. & Bremer, K. 2004 Molecular evidence on plant divergence times. *Am. J. Bot.* **91**, 1656–1665.
- Sanmartín, I. & Ronquist, F. 2004 Southern Hemisphere biogeography inferred by event-based models: plant versus animal patterns. *Syst. Biol.* **53**, 216–243. (doi:10.1080/10635150490423430.)
- Scriven, L. J. & Hill, R. S. 1995 Macrofossil Casuarinaceae: their identification and the oldest macrofossil record, *Gymnostoma antiquum* sp. nov., from the late Paleocene of New South Wales, Australia. *Aust. Syst. Bot.* **8**, 1035–1053. (doi:10.1071/SB9951035.)
- Setoguchi, H., Ono, M., Doi, Y., Koyama, H. & Tsuda, M. 1997 Molecular phylogeny of *Nothofagus* (Nothofagaceae) based on the *atpB*–*rbcL* intergenic spacer of the chloroplast DNA. *J. Plant Res.* **110**, 469–484.
- Swenson, U., Backlund, A., McLoughlin, S. & Hill, R. S. 2001a *Nothofagus* biogeography revisited with special emphasis on the enigmatic distribution of subgenus *Brassospora* in New Caledonia. *Cladistics* **17**, 28–47. (doi:10.1111/j.1096-0031.2001.tb00109.x.)
- Swenson, U., Hill, R. S. & McLoughlin, S. 2001b Biogeography of *Nothofagus* supports the sequence of Gondwana break-up. *Taxon* **50**, 1025–1041.
- Swofford, D. L. 2002 *PAUP\**. *Phylogenetic analysis using parsimony (\*and other methods)*. Sunderland, MA: Sinauer Associates.

- Van Steenis, C. G. G. J. 1971 *Nothofagus*, key genus to plant geography, in time and space, living and fossil, ecology and phylogeny. *Blumea* **19**, 65–98.
- Welch, J. J. & Bromham, L. 2005 Molecular dating when rates vary. *Trends Ecol. Evol.* **20**, 320–327. (doi:10.1016/j.tree.2005.02.007.)
- Wikström, N., Savolainen, V. & Chase, M. W. 2003 Angiosperm divergence times: congruence and incongruence between fossils and sequence divergence

estimates. In *Telling the evolutionary time: molecular clocks and the fossil record* (ed. P. C. J. Donoghue & M. P. Smith), pp. 142–165. London: Taylor & Francis.

The electronic supplementary material is available at <http://dx.doi.org/10.1098/rspb.2005.3219> or via <http://www.journals.royalsoc.ac.uk>.

As this paper exceeds the maximum length normally permitted, the authors have agreed to contribute to production costs.