

## Identification of Individuals by Analysis of Biallelic DNA Markers, Using PCR and Solid-Phase Minisequencing

Ann-Christine Syvänen,\* Antti Sajantila,\* and Matti Lukka†

\*Department of Human Molecular Genetics and †Department of Immunobiology, National Public Health Institute, Helsinki

### Summary

We have developed a new method for forensic identification of individuals, in which a panel of biallelic DNA markers are amplified by the PCR, and the variable nucleotides are detected in the amplified DNA fragments by the solid-phase minisequencing method. A panel of 12 common polymorphic nucleotides located on different chromosomes with reported allele frequencies close to .5 were chosen for the test. The allele frequencies for most of the markers were found to be similar in the Finnish and other Caucasian populations. We also introduce a novel approach for rapid determination of the population frequencies of biallelic markers. By this approach we were able to determine the allele frequencies of the markers in the Finnish population, by quantitative analysis of three pooled DNA samples representing 3,000 individuals. The power of discrimination and exclusion of the solid-phase minisequencing typing test with 12 markers was similar to that of three VNTR markers that are routinely used in forensic analyses at our institute. The solid-phase minisequencing method was successfully applied to type paternity and forensic case samples. We also show that the quantitative nature of our method allows typing of mixed samples.

### Introduction

The polymorphisms of the human genome provide excellent means for discrimination between individuals. Amplification of DNA fragments containing the polymorphic DNA regions by the PCR technique (Mullis and Faloona 1987) has greatly simplified determination of the genetic markers. Minute amounts of DNA can be amplified from virtually any type of biological material. Therefore the PCR technique is particularly useful in the identification of individuals for forensic medicine, where often only very small or even degraded samples are available for the DNA analysis.

A variety of methods for detecting the polymorphisms in the amplified DNA can be applied. DNA regions containing VNTRs (Jeffreys et al. 1985) or short tandem repeats (STRs) (Edwards et al. 1991) give rise to multiple alleles varying in length. Amplifi-

cation of the VNTR or STR regions, followed by size separation of the alleles by gel electrophoresis, is a widely used strategy in forensic analysis (Kasai et al. 1990; Budowle et al. 1991). The detection of multiple closely linked polymorphic nucleotides at the HLADQ $\alpha$  locus is also presently utilized in the identification of individuals. Six of the eight alleles at this locus can be detected by hybridization with immobilized allele-specific oligonucleotide probes by using the "reversed dot blot" method (Saiki et al. 1989). Nucleotide sequence analysis of the variable mitochondrial D-loop (Greenberg et al. 1983) can also be used in identity testing (Higuchi et al. 1988; Sullivan et al. 1991), but, because the mitochondrial DNA is maternally inherited, it is not suitable for paternity testing. The minisatellite-variant-repeat mapping method combines the detection of single nucleotide variations within a VNTR region with size analysis of the VNTR alleles and potentially allows definitive identification of an individual (Jeffreys et al. 1991).

Single nucleotide variations, which give rise to biallelic sequence polymorphism, occur very frequently in the human genomic DNA. Variable nucleotides located on different chromosomes provide a higher power of discrimination (per variable nucleotide) than

Received June 25, 1992; revision received August 31, 1992.

Address for correspondence and reprints: Dr. Ann-Christine Syvänen, Department of Human Molecular Genetics, National Public Health Institute, Mannerheimintie 166, 00300 Helsinki, Finland.  
© 1993 by The American Society of Human Genetics. All rights reserved.  
0002-9297/93/5201-0006\$02.00

do linked sequence polymorphisms, such as those at the HLADQ $\alpha$  locus. To achieve a power of discrimination similar to that of a multiallelic VNTR marker or STR marker, several biallelic markers must be analyzed in each case. This is practically feasible because single nucleotide variations can be detected by methods technically simpler than length polymorphisms, which involves size separation of the alleles. Detection of sequence polymorphisms unequivocally defines the alleles, and, consequently, interpretation problems due to incomplete resolution of individual alleles having small differences in size are avoided. Forensic DNA typing by detection of single nucleotide variations located on different chromosomes, by the reversed dot blot method (Reynolds 1991) or by the oligonucleotide ligation assay (Nickerson et al. 1990), has been suggested by others.

In this study we describe the development of a method for forensic DNA typing, in which a panel of biallelic markers are detected by the solid-phase minisequencing method (Syvänen et al. 1990). This method identifies single nucleotide variations, as well as small deletions or insertions in DNA fragments amplified by the PCR. Determination of the panel of 12 markers selected in this study proved to be an efficient and reliable method for forensic identification of individuals. We also introduce a novel approach for rapid determination of allele frequencies by quantitative analysis of pooled DNA samples and show that the quantitative nature of the solid-phase minisequencing method offers a possibility for typing mixed DNA samples.

## Materials and Methods

### DNA Samples

Blood samples were collected from volunteers among the laboratory staff. The case samples had been sent, because of disputed paternity analysis or for forensic identification, to the National Public Health Institute (Helsinki). A rapid cell-lysis procedure was applied to prepare the blood samples for the PCR (Higuchi 1989). The stain samples (about 3-mm<sup>2</sup> blood stains on fabric) were incubated in 100  $\mu$ l *Taq* DNA polymerase buffer (see below) for 1 h at 20°C, and the samples were boiled for 10 min.

Eighteen batches of pooled leukocytes, each of which originated from an equal amount of blood from 90 or 180 donors and had previously been used in the production of interferon- $\alpha$  (Cantell et al. 1981), were

obtained from the Finnish Red Cross Blood Transfusion Service. DNA was purified from a small aliquot of each leukocyte batch by a standard method (Bell et al. 1981). The concentration of the DNA was determined by measuring the absorbance at 260 nm. The leukocyte DNA was combined into three larger pools containing an equal amount of DNA from about 1,000 individuals each.

### Primers

The PCR and minisequencing detection-step primers were designed according to published sequence information (see table 1). A fragment spanning the D21S13E locus was amplified from DNA samples of different genotype, with primers described by Stinissen and Van Broeckhoven (1991), and the PCR products were sequenced by a modification of the dideoxy chain-termination method (Casanova et al. 1990). The primers for typing the D21S13E site were designed on the basis of the nucleotide sequence obtained.

The primers were synthesized on an Applied Biosystems 392 DNA/RNA synthesizer. The primers denoted by "Bio" in table 1 were biotinylated at their 5' end according to a method described elsewhere (Bengtström et al. 1990), or, alternatively, the biotin residue was added to the 5' end of the primers during the synthesis by using a biotinyl phosphoramidite reagent (Misiura et al. 1990) (RPN 2012; Amersham).

### PCR

Five microliters of cell lysate (approximately  $2 \times 10^4$  DNA molecules), 25–50 ng of purified DNA, or 1/20 of stain extract was added to each reaction. The PCR mixtures contained 10 pmol of biotinylated primer, 50 pmol of unbiotinylated primer, the four dNTPs at 0.2 mM concentrations, and 1.25 units of *Thermus aquaticus* (*Taq*) DNA polymerase (Promega Biotech) in 50  $\mu$ l of 50 mM Tris-HCl (pH 8.8), 15 mM (NH<sub>4</sub>)<sub>2</sub>SO<sub>4</sub>, 1.5 mM MgCl<sub>2</sub>, 0.1% Triton X-100, and 0.01% gelatin (*Taq* DNA polymerase buffer). The PCR was initiated with a "hot start" by first heating the samples for 5 min at 95°C, followed by addition of the *Taq* DNA polymerase at 80°C. Thirty PCR cycles of 1 min at 95°C, 1 min at 58°C (markers ADH3, ARSB, METH, and LDLR) or at 54°C, and 1 min at 72°C were carried out in test tubes or microtiter plate wells in a programmable heat block (MJ Research). "Multiplex" PCR with two or more primer pairs in one reaction was carried out at the same conditions, with 10 pmol of each biotinylated primer, and

**Table 1**

**PCR and Solid-Phase Minisequencing Primers**

Marker <sup>a</sup>	Chromosomal Localization	Sequence (5'→3')	Position <sup>b</sup>	Reference(s)	Size of PCR Product (bp)	Polymorphic Nucleotide
ADH3 .....	4q21-23	CCAAACTTGTGGCTGACTTTATGGC	831-855	Höög et al. 1986	116	A <sub>890</sub> →G
		Bio-ACCTCTTTCCAGAGCGAAGCAGGT ms:CACTGGATGCATTAATAACAAAT				
ARSB .....	5q13-14	GAGGGTGGGCTTTGTGGCAAG	986-1007	Peters et al. 1990	131	A <sub>1072</sub> →G
		Bio-GAGGCTTTGTGCCATTTGGTGTGT ms:TGACTGGCTGCCAACACTC				
METH .....	7q21-31	Bio-CATCCATGTAGGAGGCCCTTAGTC	9-32	Horn et al. 1990	223	A <sub>127</sub> →G
		CCATTTTGTGTCCTTCTAGTCTAAGG ms:TTGAAAGATCGTCAGAAAATCC				
LDLR .....	19p13.3-13.1	Bio-TCTCCTTATCCACTTGTGTCTAG	(-10)-12/15	Leitersdorf and Hobbs 1988	190	A <sub>83</sub> →G
		TTCGATCTCGTACGTAAAGCCACAC ms:GGTCTTCGGTTGCCCC				
APOB .....	2p24-23	CAAAATAACCTTAATCATCAATTGGTTA	7580-7607	Knott et al. 1986	213	C <sub>7664</sub> →T
		Bio-AGCAGCAAGAGTCCACCAATCAG ms:AAGGCCAAATCCGAGAGAC				
PROS1 .....	3p11.1-q11.2	GTACAGTTGGATCTGGATGAAGCC	15/122-15/144	Ploos van Amstel et al. 1990	117	A <sub>183</sub> →G
		Bio-GGTATTATAAGCAGAGAAAAGATGCC ms:ATTAGAGCTCACTCATGTCC				
PRP .....	20p12-pter	GCAGTGGTGGGGGGCCTTGG	407-426	Kretzschmar et al. 1986	58	A <sub>434</sub> →G
		Bio-ATGATGGGCTGCTCATGGCAC ms:TGGGGGGCCTTGGGGGCTAC				

D21S13E ...	21q11.2	{ ATCTAAAAACAGATAGGTCAGTGTCT Bio-GGGTTCTAAAGGGAAGAAAG AGCTCAGTGTCTATGCTTTC	Stinissen and Van Broeck- hoven 1991; present study	104/107	T→G <sup>c</sup>
3BHS	1p13	{ AAAACGGTGGAGTGGTTGGTTCC Bio-GTGCCCTTGTCACCTTCTGTATGAG ms:CTGGACCGGCACAAGGAGA	Lachance et al. 1990	160	A <sub>7149</sub> →C
LPL	8p22	{ Bio-CTGCTGCCTGCAAGGTTTGTCT AACAGAAGAACAACAACAAACCC ms:ACAAACAAACCCACAGCT	Oka et al. 1989	86	A <sub>497</sub> →G
IGF2	11p15.5	{ TGCCCTGGACTTGAGTCCCTGA Bio-ACGAGCGACGTGCCACCTGT ms:GAACCCAGAAAGAAAAGG	De Pagter-Holthuisen et al. 1988	75	A <sub>820</sub> →G
BCL2	18q21	{ AGAGGTGCCGTGGCCCGTTGTCG Bio-TTCATCACTATCTCCCGTTGTCG ms:ATGGCGCACGCTGGGAGAAC	Tsujimoto and Croce 1986	90	A <sub>21</sub> →G
VWF	12pter-p12	{ GGGGTGCAGCAAAGTCAACCTGT Bio-TAAGGGATGGGTGTGCCAGCC ms:TTGCCATGGATGGCCAGGAC	Mancuso et al. 1989	228	A <sub>212</sub> →G
TP53	17p13	{ GTATTGGATGCAACTGGGGTCTC Bio-GGCCCTTAGCCTCGTAAGCTTCA ms:CTGGTTGTCAGTGGCCCTCC	Chumakov 1990 <sup>d</sup>	248	A <sub>13494</sub> →G

<sup>a</sup> ADH3 = alcohol dehydrogenase; ARSB = arylsulfatase B; METH = met proto-oncogene; LDLR = low-density-lipoprotein receptor; APOB = apolipoprotein B; PROS1 = protein S; PRP = prion protein; 3BHS = 3β-hydroxysteroid dehydrogenase; LPL = lipoprotein lipase; IGF2 = insulin-like growth factor II; BCL2 = B-cell lymphoma/leukemia protein 2; VWF = von Willebrand factor; and TP53 = transformation-related protein p53.

<sup>b</sup> Nucleotide numbering is according to the reference given. For the LDLR and BCL2 markers, the numbers in parentheses refer to intronic nucleotides. For LDLR and PROS1, the numbers followed by a slash refer to exon 12 and exon 15, respectively. For VWF, the number 9 refers to blocks of sequences given by Mancuso et al. (1989).

<sup>c</sup> The polymorphism is an insertion of 4 T's.

<sup>d</sup> EMBL data library accession no. X54156.

50 pmol of each unbiotinylated primer, and 2.5 units of *Taq* DNA polymerase.

Table 1 gives the expected sizes of the PCR products. The correct size and quality of the PCR products were initially assessed by electrophoresis in 2% agarose gels.

#### Solid-Phase Minisequencing

Figure 1 shows the principle of the method. Either 1/10 of each single PCR product or 1/20 of the multiplex PCR products was analyzed in each solid-phase minisequencing reaction. The biotinylated PCR products were captured in streptavidin-coated microtitration wells (Orion Diagnostica, Espoo, Finland; or Labsystems, Helsinki) in 50  $\mu$ l of 20 mM sodium phosphate buffer (pH 7.5), 0.1 M NaCl, and 0.1% Tween 20 by incubating the microtiter plates with gentle shaking for 1.5 h at 37°C. The wells were washed five times with 200  $\mu$ l of 40 mM Tris-HCl (pH 8.8), 1 mM EDTA, 50 mM NaCl, and 0.1% Tween 20 at 20°C, either manually or by using an automatic plate washer (Delfia® 1296-024; Pharmacia). The bound PCR fragments were denatured by treating the wells with 100  $\mu$ l of 50 mM NaOH for 5 min at 20°C, and the wells were washed as above.

Fifty microliters of minisequencing reaction mixture containing 10 pmol of one detection step primer, 0.1  $\mu$ Ci of one  $^3\text{H}$ [dNTP], and 0.05 units of *Taq* DNA polymerase in *Taq* DNA polymerase buffer was added to each well. Table 1 gives the appropriate primer and  $^3\text{H}$ [dNTP] for detection of each polymorphic nucleotide. The following  $^3\text{H}$ [dNTP]s were used:  $^3\text{H}$ [dATP] (specific activity 40–62 Ci/mmol; TRK 633; Amersham),  $^3\text{H}$ [dCTP] (52 Ci/mmol; TRK 625),  $^3\text{H}$ [dGTP] (31–37 Ci/mmol; TRK 627), and  $^3\text{H}$ [dTTP] (113 Ci/mmol; TRK 576). The microtiter plates were incubated for 10 min at 50°C, and the wells were washed as described above. Finally, the wells were treated with 60  $\mu$ l of 50 mM NaOH for 5 min at 20°C to release the elongated detection-step primer, and the eluted radioactivity was measured in a liquid scintillation counter (Wallac 1209 Rackbeta or Wallac 1450 microbeta).

#### Statistical Evaluations

A  $\chi^2$  test comparing observed and expected genotypes was performed to assess whether the Finnish population sample conforms to Hardy-Weinberg expectations. The expected genotypes were calculated from the observed allele frequencies. Both the power of discrimination between individuals of the panel of

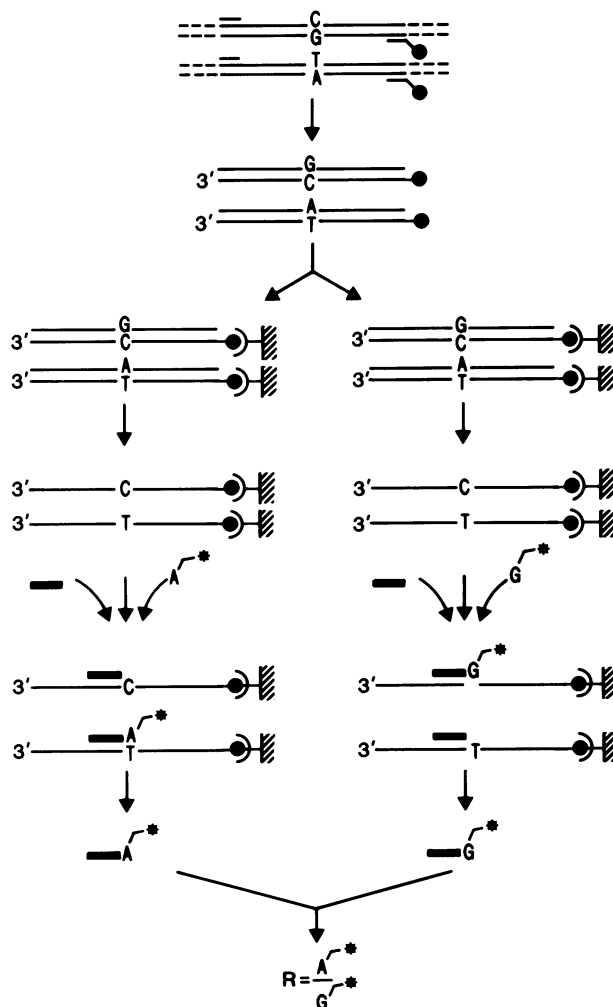

**Figure 1** Principle of the solid-phase minisequencing method. A DNA fragment spanning the polymorphic site is amplified using a biotinylated and an unbiotinylated PCR primer. The biotinylated PCR product is captured in a streptavidin-coated microtitration well, and the unbiotinylated DNA strand is removed by alkaline denaturation. The nucleotides at the polymorphic site are identified in the immobilized DNA strand by two separate minisequencing reactions. In this reaction a detection-step primer annealing immediately adjacent to the mutation is elongated by a DNA polymerase with one single  $^3\text{H}$ -labeled dNTP complementary to the nucleotide at the polymorphic site. After the reaction the detection-step primer is released, and the incorporated label is measured in a scintillation counter. The result of the test is expressed as the ratio between the labels incorporated in the two reactions.

12 markers and the probability of a random match in the homicide case were calculated from the observed genotype frequencies as described by Jones (1972). The power of exclusion with the 12 markers in paternity analyses was calculated using a computer

program provided by Dr. Matti Kataja (Tampere, Finland). The percentage of potential fathers and paternity indexes in the individual cases were calculated according to the method of Grtler (1956).

#### *Analysis of VNTR Loci and Conventional Markers*

The paternity and forensic case samples were typed by amplified fragment-length polymorphism (AmpFLP) analysis (Budowle et al. 1991) of the D1S80, D17S30, and ApoB 3' VNTR loci, at conditions described elsewhere (Sajantila et al. 1992b). In addition, the paternity case samples were typed using the following 10 conventional markers: the ABO, MNSs, Rh, and Kell (K) erythrocyte antigens; the adenylate kinase, phosphoglucomutase, and acidic phosphatase erythrocyte enzymes; serum haptoglobin; group-specific component; and transferrin (Nevanlinna 1980; Lukka et al. 1985, 1986).

## **Results**

### *The Biallelic DNA Markers*

Fourteen polymorphic biallelic markers were initially selected for the solid-phase minisequencing test, with the following considerations: (1) to be as informative as possible, the allele frequencies at the polymorphic sites should be close to .5; (2) the markers should be located on different chromosomes; and (3) complete sequence information on the region surrounding the polymorphic site should be available for design of the PCR and minisequencing detection-step primers. Table 1 shows the chromosomal location of the markers, the sequences and positions of the primers, and the polymorphic nucleotide. All markers except LPL and D21S13E are located in coding regions of the genome. Twelve of the polymorphisms are caused by nucleotide transitions; one is a transversion; and one is an insertion of four nucleotides. The alleles at each site are here designated according to the  $^3\text{H}[\text{dNTP}]$  incorporated by the minisequencing reaction.

### *Population Frequencies of the Genotypes and Alleles*

The distribution of the genotypes and alleles at each polymorphic site in the Finnish population was determined by analyzing individual DNA samples by the solid-phase minisequencing method. The result of the assay is expressed as the ratio between the two incorporated  $^3\text{H}[\text{dNTP}]$ s corresponding to the nucleotide at the polymorphic site (the *R* value). The *R* values

fall into three distinct categories, which unequivocally define the genotype of the individuals (table 2). In addition to the genotype of the sample, the *R* value is affected by the sequence of nucleotides following the polymorphic site, which determines the number of  $^3\text{H}[\text{dNTP}]$ s that will be incorporated into each allele. In most of the alleles one  $^3\text{H}[\text{dNTP}]$  will be incorporated. Table 2 shows the *R* values obtained by typing 10 representative samples at the ADH3 and METH loci, at which one or three  $^3\text{H}[\text{dGTP}]$ s will be incorporated into the G allele, respectively. The *R* value is also affected by the specific activities of the particular  $^3\text{H}[\text{dNTP}]$ s used. In all cases the *R* values obtained in samples from heterozygous individuals differ by at least a factor of 10 from those obtained in samples from homozygous individuals.

Table 3 summarizes the allele and genotype frequencies of the markers observed in the Finnish population. For most of the markers the allele frequencies in the Finnish population were similar to those reported from other Caucasian populations, but for the ARSB, VWF, and TP53 markers significant differences in the allele frequencies were observed. For all markers the observed genotypes conform to Hardy-Weinberg expectations.

### *Determination of Allelic Frequencies by Quantitative Analysis of Pooled DNA Samples*

The ratio between the two labeled dNTPs incorporated at each site in the minisequencing reaction directly reflects the proportion of the two sequences in the sample also when the sequences are present in other than the predefined 1:1 (heterozygote) or 2:0 (homozygote) ratios. Taking advantage of this quantitative feature of the minisequencing method, we determined the allele frequencies of each marker by analyzing DNA isolated from pooled leukocytes. Three pools, each of which represented about 1,000 individuals living in the capital region of Finland and contained an equal amount of DNA from each individual, were analyzed at each polymorphic site. The ratio between the two sequences in the pooled DNA samples, which is equivalent to the allele frequencies in the population sample, was calculated from the obtained *R* value by comparing it with the mean *R* value obtained in samples from heterozygous individuals, in which the alleles are, by definition, present in a 1:1 ratio. Alternatively, the allelic frequencies can be calculated by taking into account the specific activities and the number of  $^3\text{H}[\text{dNTP}]$ s incorporated at each site. The allelic frequencies determined from the pooled sam-

**Table 2****Genotyping of 10 Samples at the ADH3 and METH Loci, by Solid-Phase Minisequencing**

SAMPLE	ADH3				METH			
	<sup>3</sup> H[dNTP] Incorporated <sup>a</sup> (cpm)		R Value: A <sub>cpm</sub> /G <sub>cpm</sub>	Genotype <sup>b</sup>	<sup>3</sup> H[dNTP] Incorporated <sup>a</sup> (cpm)		R Value: A <sub>cpm</sub> /G <sub>cpm</sub>	Genotype <sup>b</sup>
	A Allele	G Allele			A Allele	G Allele		
1 .....	6,550	61	107	AA	53	4,570	.011	GG
2 .....	5,430	43	129	AA	713	1,110	.64	AG
3 .....	2,620	30	90	AA	1,590	110	14.4	AA
4 .....	3,300	1,770	1.86	AG	688	1,400	.49	AG
5 .....	4,380	44	101	AG	45	1,690	.026	GG
6 .....	160	2,800	.057	GG	970	1,530	.63	AG
7 .....	5,520	42	131	AA	1,690	130	12.5	AA
8 .....	2,240	1,210	2.02	AG	1,120	2,160	.52	AG
9 .....	2,610	1,470	1.77	AG	1,900	105	18.0	AA
10 .....	170	5,170	.034	GG	1,030	1,940	.53	AG
H <sub>2</sub> O .....	30	39	...	...	27	38	...	

<sup>a</sup> At both sites, one <sup>3</sup>H[dATP] will be incorporated into the A allele. At the ADH3 site, one <sup>3</sup>H[dGTP] will be incorporated into the G allele, and at the METH site three <sup>3</sup>H[dGTP]s will be incorporated into the G allele. In the analysis of the ADH3 marker, the specific activities of <sup>3</sup>H[dATP] and <sup>3</sup>H[dGTP] were 62 Ci/mmol and 31 Ci/mmol, respectively. In the analysis of the METH marker, the corresponding specific activities were 40 Ci/mmol and 61 Ci/mmol.

<sup>b</sup> Deduced from the observed A<sub>cpm</sub>/G<sub>cpm</sub> ratio.

ples were in good agreement with those observed by analyzing individual samples (table 3).

#### Properties of the Panel of Markers

The 12 most informative markers were selected for further study. The power of discrimination between individuals, when the selected marker panel is used, is calculated to be .99996 in the Finnish population. The corresponding figure for the combination of the D1S80, D17S30, and the ApoB 3' VNTR loci is .9998 (data not shown; A. Sajantila, unpublished data). The power of exclusion of the marker panel in paternity testing is .901; the corresponding figure for the 3 VNTR markers is .920; and that for the 10 protein markers is .913 (data not shown). Mendelian inheritance was demonstrated for each marker by analysis of 60 meioses in 14 families.

#### Design of the Typing Method

Multiplex PCRs with different combinations of the 12 PCR primer pairs were investigated, and the optimal amount of the PCR products subjected to the solid-phase minisequencing reaction was determined. The biotin-binding capacity of the microtitration-wells set an upper limit to the amount of biotinylated PCR products (and excess of biotinylated primers) that can be present in the minisequencing reaction.

For this reason, during the PCR the biotinylated primers were used at lower concentration than were the unbiotinylated ones. The best result was obtained by carrying out three separate PCRs with four pairs of primers in each reaction, followed by analysis of 1/20 of the PCR product (containing a total of 2 pmol of biotinylated primer) per microtitration well. The following markers were combined: ADH3, ARSB, METH, and LDLR; APOB, PROS1, PRP, and D21S13E; and 3BHSD, LPL, IGF, and BCL2. The signals obtained in the minisequencing reaction after multiplex PCR were about 40% of those obtained when each marker was amplified individually, but the R values remained unaltered.

#### Application to Paternity and Forensic Cases

The solid-phase minisequencing method was used to solve two cases of disputed paternity, both of which included two putative fathers. Table 4 gives the genotypes determined from blood samples of the mother, the child, and the two men, in both cases. In case I the result obtained with the marker BCL2 excluded man 1 as the father, and in case II exclusion of man 1 was obtained with the markers ADH3, LDLR, APOB, and D21S13E. This result is in accordance with that obtained with 10 conventional markers and 3 VNTR markers (data not shown). The power of exclusion

**Table 3****Genotype and Allele Frequencies of the Markers**

MARKER (no. of chromosomes analyzed)	GENOTYPE FREQUENCY	ALLELE FREQUENCY			REFERENCE
		Individual Samples	Pooled <sup>a</sup> Samples	Previously Reported <sup>b</sup> (no. of chromosomes)	
ADH3 (152) .....	{ AA .28 AG .47 GG .25	A .51 G .49	A .58 G .42	A .50 HE43 G .50 HE44 } (24)	Xu et al. 1988
ARSB (128) .....	{ AA .36 AG .55 GG .09	A .63 G .37	A .67 G .33	A .38 358-Met G .62 358-Val } (220)	Jin et al. 1991
METH (106) .....	{ AA .30 AG .47 GG .23	A .54 G .46	A .58 G .42	A .57 <i>MspI</i> <sup>+</sup> G .43 <i>MspI</i> <sup>-</sup> } (20)	Horn et al. 1989
LDLR (140) .....	{ AA .19 AG .48 GG .33	A .43 G .57	A .45 G .55	A .45 <i>HincII</i> <sup>+</sup> G .55 <i>HincII</i> <sup>-</sup> } (20)	Leitersdorf and Hobbs 1988
APOB <sup>c</sup> (174) .....	{ CC .31 CT .49 TT .20	C .56 T .44	C .55 T .45	C .51 X1 T .49 X2 } (56)	Soria et al. 1989
PROS1 (104) .....	{ AA .46 AG .29 GG .25	A .61 G .39	A .58 G .42	A .52 CGA G .48 CCG } (212)	Diepstraten et al. 1991
PRP (100) .....	{ AA .53 AG .43 GG .04	A .74 G .26	A .66 G .34	A .62 Met-129 G .38 Val-129 } (212)	Collinge et al. 1991
D21S13E (130) ....	{ TT .46 TG .35 GG .19	T .64 G .36	T .72 G .28	T .60 A1 C .40 A2 } (212)	Stinissen and Van Broeckhoven 1991
3BHSD (100) .....	{ AA .68 AC .28 CC .04	A .82 C .18	A .77 G .23	A .68 AAC C .32 ACC } (78)	Rhéaume et al. 1991
LPL (96) .....	{ AA .25 AG .54 CC .21	A .52 G .48	A .52 G .48	A .41 <i>PvuII</i> <sup>-</sup> G .59 <i>PvuII</i> <sup>+</sup> } (98)	Fisher et al. 1987
IGF2 (108) .....	{ AA .04 AG .57 GG .39	A .32 G .68	A .20 G .80	A .47 <sup>d</sup> D1 G .53 <sup>d</sup> D2 } (130)	Tadokoro et al. 1991
BCL2 (118) .....	{ AA .32 AG .54 GG .14	A .59 G .41	A .56 G .44	A .51 A G .49 G } (160)	Tanaka et al. 1991
VWF (92) .....	{ AA 0 AG .20 GG .80	A .10 G .90	A .14 G .86	A .55 <i>AatII</i> <sup>-</sup> G .45 <i>AatII</i> <sup>+</sup> } (80)	Bowen et al. 1991
TP53 (42) .....	{ AA 0 AG .14 GG .86	A .07 G .93	A .08 G .92	A .31 K1 G .69 K2 } (112)	Chumakov and Jenkins 1991

<sup>a</sup> Mean values of five parallel assays of three pools representing about 1,000 individuals each.

<sup>b</sup> The allele designation used in the reference cited is given on the right.

<sup>c</sup> The APOB allele frequencies have been determined, in an earlier study by RFLP analysis with *XbaI*, to be X1 .56 and X2 .44 in a population sample of 140 individuals from western Finland and to be X1 .59 and X2 .41 in a population sample from 167 individuals from eastern Finland (Aalto-Setälä et al. 1991).

<sup>d</sup> Determined in a Japanese population sample.



was .89 in case I and .94 in case II. The calculated paternity index for man 2 was 11.4 in case I and 16.9 in case II.

The method was also applied to a homicide case, which included reference blood samples from two victims and two suspects and three stain samples. As can be seen from table 4, which shows the genotypes determined from these samples, the genotype of stain 1 matches with the genotype determined from the blood sample of suspect 2, and the genotypes of stain 2 and stain 3 match with those of victim 2 and victim 1, respectively. From the result in table 4 it can be seen that each of the three other reference samples was excluded as the source of the stain, by the first set of four markers amplified in one multiplex PCR (ADH3, ARSB, METH, and LDLR). In the Finnish population the probabilities of a random match for individuals of the genotypes determined from the stain samples are 1/85,000 (stain 1), 1/50,000 (stain 2), and 1/2,100,000 (stain 3). The result obtained with the solid-phase minisequencing test is consistent with that obtained with three VNTR markers (data not shown).

In the minisequencing analysis of the three stain samples the *R* values obtained at each polymorphic site clearly fell within the ranges of *R* values previously defined for heterozygous and homozygous individuals by the analysis of individual samples. This shows that

each stain contained DNA originating from only one individual.

#### Analysis of Mixed Samples

In some cases forensic stain samples can contain mixtures of DNA from the victim and the suspect. The following experiment, in which mixed DNA samples were analyzed, was carried out. DNA from two individuals of the genotypes METH GG/ADH3 AG, and METH AA/ADH3 GG, respectively, were mixed in 9:1, 1:1, 2:3, and 1:9 ratios, and the mixtures were analyzed at the METH and ADH3 loci. Figure 2 compares the *R* values determined from the mixed samples with the range of *R* values observed when the allelic frequencies at these loci were determined from individual samples (see table 3). At the METH locus, *R* values falling outside the normal ranges were obtained in the 9:1 mixture (10% A allele), the 2:3 mixture (60% A allele), and the 1:9 mixture (90% A allele). As expected, the 1:1 mixture (50% A allele) yielded an *R* value corresponding to a heterozygote. At the ADH3 locus, *R* values clearly falling outside the normal ranges were obtained with the 2:3 mixture (25% A allele), 1:1 mixture (20% A allele), and 1:9 mixture (5% A allele). The 9:1 mixture (45% A allele) was on the borderline for the range of *R* values of heterozygotes. This experiment demonstrates that the quanti-

**Table 4**

**Genotypes Determined by the Solid-Phase Minisequencing Method, in Paternity and Homicide Cases**

Sample	ADH3	ARSB	METH	LDLR	APOB	PROS1	PRP	D21S13E	3BHSB	LPL	IGF2	BCL2
Paternity case I:												
Mother .....	AA	AG	AG	AG	CT	AA	AG	TG	AC	GG	GG	AG
Child .....	AA	AG	GG	GG	TT	AA	AG	TG	AC	GG	GG	GG
Man 1 .....	AA	AA	AG	GG	CT	AG	AG	TG	AC	AG	GG	<u>AA</u>
Man 2 .....	AG	AG	AG	GG	CT	AG	AG	TT	AC	GG	GG	<u>GG</u>
Paternity case II:												
Mother .....	GG	AA	AA	GG	CT	AG	AA	TT	AC	GG	AG	AA
Child .....	GG	AG	AA	GG	CC	AG	AA	TG	AC	GG	AG	AG
Man 1 .....	<u>AA</u>	AG	AG	<u>AA</u>	<u>TT</u>	AG	AG	<u>TT</u>	AC	AG	AG	AG
Man 2 .....	AG	AG	AA	AG	CC	AG	AG	GG	AC	AG	AG	GG
Homicide case:												
Victim 1 .....	AG	GG	AA	AG	CT	AG	GG	TG	AC	AG	GG	AG
Victim 2 .....	AA	AA	AA	AG	CT	AG	AA	TT	AC	AG	GG	AG
Suspect 1 .....	AA	GG	AG	AG	CC	AG	AG	TG	AC	AA	GG	AG
Suspect 2 .....	AG	AG	AG	GG	CT	AG	GG	TT	AC	AA	AG	AG
Stain 1 .....	AG	AG	AG	GG	CT	AG	GG	TT	AC	AA	AG	AG
Stain 2 .....	AA	AA	AA	AG	CT	AG	AA	TT	AC	AG	GG	AG
Stain 3 .....	AG	GG	AA	AG	CT	AG	GG	TG	AC	AG	GG	AG

NOTE.— Underlined genotypes are those that excluded man 1 as the father.

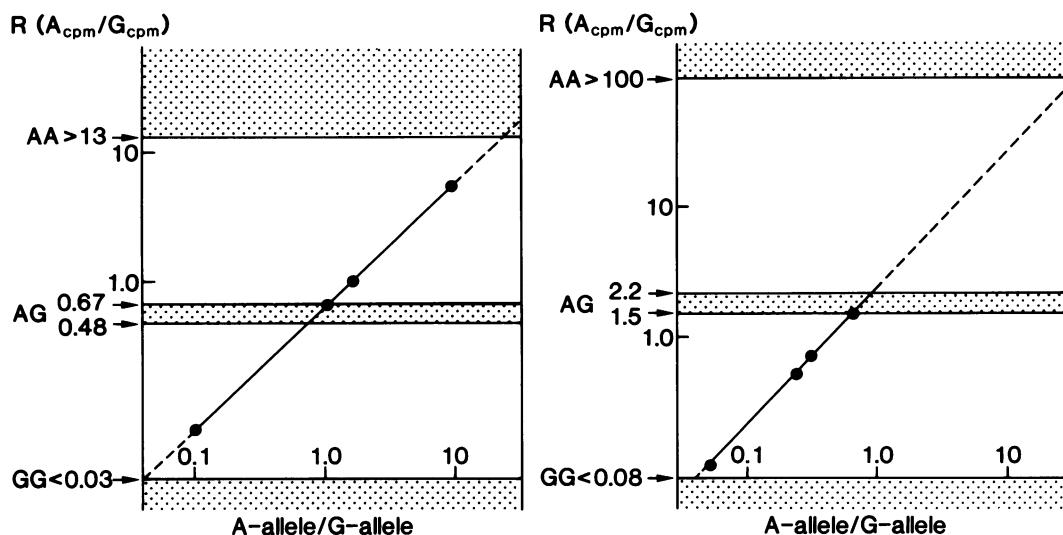

**Figure 2** R values determined from DNA samples prepared by mixing DNA from two individuals of the genotypes METH GG/ADH3 AG and METH AA/ADH3 GG in 9:1, 1:1, 2:3, and 1:9 ratios. *Left*, Analysis at the METH locus. The mixed samples contained the METH A and G alleles in the ratios 0.11 (10% A allele), 1.0 (50% A allele), 1.5 (60% A allele), and 9.0 (90% A allele). *Right*, analysis of the ADH3 locus. The mixed samples contained the ADH3 A and G alleles in the ratios 0.82 (45% A allele), 0.33 (25% A allele), 0.25 (20% A allele), and 0.053 (5% A allele). The range of R values obtained in the analysis of 76 individual samples at the ADH3 locus and of 53 samples at the METH locus is denoted by the shaded areas.

tative nature of our method allows identification of the presence of DNA from two individuals in any mixture between about 9:1 and 1:9. The minimal requirement for this is that one of the individuals be a heterozygote and that the other one be homozygous for either allele at the same site, which is highly probable when 12 markers are analyzed. If the two individuals are homozygous for different alleles at another site, the reliability of identifying a mixed sample is further improved.

When a mixed sample has been identified at a minimum of two sites with different genotype combina-

tions, the genotypes at each site can be determined. This is accomplished by pairwise comparison of the R values at the two informative sites. Table 5 presents a theoretical example of the relationship between the R values in mixtures of DNA from two individuals with the three possible combinations of different genotypes. Table 5 also gives the formulas describing the general arithmetic relationship between each pair of R values from different genotype combinations. The genotypes in a mixed sample are deduced by testing into which of the formulas two R values fit. In addi-

**Table 5**

**Theoretical Illustration of the Typing of Mixed Samples from Two Individuals**

MIXED DNA SAMPLE	GENOTYPE COMBINATION					
	GG + AA		AG + GG		AG + AA	
	A Allele (%)	$R_1(A/G)^a$	A Allele (%)	$R_2(A/G)^b$	A Allele (%)	$R_3(A/G)^c$
9:1 .....	10	.11	45	.82	55	1.22
1:1 .....	50	1.0	25	.33	75	3
2:3 .....	60	1.5	20	.25	80	4
1:9 .....	90	9.0	5	.053	95	19

<sup>a</sup>  $R_1 = (R_3 - 1)/2$ ; and  $R_1 = (1 - R_2)/2R_2$ .

<sup>b</sup>  $R_2 = 1/R_3$ ; and  $R_2 = 1/(1 + 2R_1)$ .

<sup>c</sup>  $R_3 = 1/R_2$ ; and  $R_3 = 1 + 2R_1$ .

tion, the proportion between the two samples in the mixture can be calculated, although this may not be relevant in identity-testing analyses. At the sites where both individuals are of the same genotype, any mixture of their DNA will obviously yield an  $R$  value corresponding to that of a single individual, and the genotypes at these sites are thus defined.

## Discussion

We have developed a new method for identification of individuals, in which a panel of 12 biallelic nucleotides are detected by the solid-phase minisequencing method (Syvänen et al. 1990). The method is particularly suitable for the simultaneous detection of multiple nucleotide variations in a large number of samples. First, the method is generally applicable for detection of any variable nucleotide, and the hybridization conditions employed for annealing of the minisequencing detection step primer are nonstringent. Therefore, the same reaction conditions can, contrary to hybridization with allele-specific probes, be applied for analysis of all sites. Second, the solid-phase reactions in a microtitration-well format make the test suitable for automatization. Nonradioactive detection methods are also applicable (Syvänen et al. 1990; Jalanko et al. 1992). Third, the result of our test is obtained as numeric values that unequivocally define the genotype of the individuals. This facilitates computer-assisted interpretation and handling of the data.

The AmpFLP technique (Allen et al. 1989; Budowle et al. 1991), in which PCR-amplified VNTR alleles of varying size are detected by PAGE and silver staining, is at present successfully used in several laboratories, including ours, for forensic identification and paternity testing (Helminen et al. 1992; Sajantila et al. 1992*b*). The amplification of VNTR alleles containing multiple repeats with the same nucleotide sequence requires careful optimization of the PCR conditions and of the amount of DNA template, to avoid spurious PCR products (Jeffreys et al. 1988; Sajantila et al. 1992*b*) and preferential amplification of (usually) the smaller allele (Jeffreys et al. 1988; Walsh et al. 1992). Both these problems are avoided in the solid-phase minisequencing typing method, where the two alleles are of equal size and have essentially equal nucleotide sequences. In our method a nucleotide substitution occurring in one allele immediately adjacent or at the polymorphic position would lead to incorrect interpretation of the genotype. In view of the fact that the mutation rate of the total human genome ( $3 \times 10^9$

nucleotides) is about three nucleotides per cell generation, the probability of detecting a mutation at one of the three critical nucleotide positions is practically nonexistent.

A disadvantage of detecting sequence polymorphisms in forensic identity testing is that typing of samples containing DNA from more than one individual is more difficult than when length polymorphisms are analyzed. However, the  $R$  value obtained in the test directly reflects the ratio of the alleles initially present in the sample. If the  $R$  value in a sample falls outside the range of  $R$  values defined by analyzing samples from single individuals, this indicates that the sample contains DNA from more than one individual. The microtiter-plate format allows detection of one DNA sequence present in about 5% of a sample. If the test is converted to a bead-based format, 0.15% of one sequence can be detected from an excess of 99.85% of another sequence (Syvänen et al. 1992). The theoretical example in table 5 shows that the genotype of the samples in a mixture can be deduced by comparing the  $R$  values at a minimum of two sites having different genotype combinations.

Using the solid-phase minisequencing method, we were able to determine, in a few reactions, the allele frequencies of each marker in the Finnish population, by quantitative analysis of pooled DNA samples representing 3,000 individuals. If leukocyte pools such as those analyzed in this study are not available, pooled samples can be prepared by mixing equal volumes of blood, blood samples containing equal amounts of leukocytes, or equal amounts of purified DNA. The good agreement between the allele frequencies determined from pooled and individual samples suggests that our method could, in the future, be a general, cost-effective way of establishing population frequencies of genetic markers. To be acceptable to official agencies, this novel approach needs to be further evaluated in other populations and with more genetic markers.

Determination of the population frequencies of genetic markers is particularly interesting in Finland. Differences between the Finnish and other Caucasian populations have been shown with polymorphic protein markers (Nevanlinna 1980). The genetic isolation of the Finns is also demonstrated by the "Finnish disease heritage," which includes about 30 mostly recessively inherited diseases that are common in Finland and practically nonexistent in other populations (Nevanlinna 1972). On the other hand, in a study of the allele distribution at the D1S80 VNTR locus by using

the AmpFLP technique, similar allele frequencies were observed in the Finnish and a North American population (Sajantila et al. 1992a). In the present study of 14 biallelic markers, most of which were located in coding regions, three of the markers showed a significant difference in the allelic frequencies, compared with that reported from other Caucasian populations, and for one marker there was a significant difference compared with that in a Japanese population.

The panel of 12 markers selected for the solid-phase minisequencing test yielded a power of discrimination and exclusion similar to that shown by the three VNTR markers routinely used in forensic identification at our institute. Since biallelic polymorphisms are very frequent in the human genome, and since detection of the polymorphic nucleotide is technically simple, the power of the minisequencing test can easily be further improved by including additional markers.

The solid-phase minisequencing method was applied to type samples from two paternity cases and one homicide case, which were randomly chosen among our routine cases. In all three cases the result was consistent with that obtained by the routine methods, which include typing of three VNTR loci and 10 protein markers, in the paternity tests.

The solid-phase minisequencing method is particularly attractive for use in routine laboratories, where large numbers of samples are analyzed, and it is a promising alternative for DNA-based identification in paternity testing and forensic casework. Obviously it can also be applied for analyzing biallelic markers and haplotypes in genetic linkage analysis and population studies.

## Acknowledgments

We thank Professor Leena Peltonen for help and support during this study, Professor Christian Ehnholm for critical reading of the manuscript, and Professor Hans Söderlund for helpful discussions. We are grateful to Ms. Tiiu Antinen, Kirsti Höök, Soile Johansson, Seija Käyhkö, Seija Puomilahti, Ritva Timonen, and Anne Wikman for assistance with the numerous assays and to Ms. Sari Röksä for excellent secretarial assistance. Dr. Hanna-Leena Kauppinen gave us access to the leukocyte pools, which is gratefully acknowledged.

## References

- Aalto-Setälä K, Viikari J, Åkerblom HK, Kuusela V, Kontula K (1991) DNA polymorphisms of the apolipoprotein B and A-I/C-III genes are associated with variations of serum low density lipoprotein cholesterol level in childhood. *J Lipid Res* 32:1477-1487
- Allen RC, Graves G, Budowle B (1989) Polymerase chain reaction amplification products separated on rehydratable polyacrylamide gels stained with silver. *BioTechniques* 7:736-744
- Bell GI, Karam JH, Rutter WJ (1981) Polymorphic DNA region adjacent to the 5' end of the human insulin gene. *Proc Natl Acad Sci USA* 78:5759-5763
- Bengtström M, Jungell-Nortamo A, Syvänen A-C (1990) Biotinylation of oligonucleotides using a water soluble biotin ester. *Nucleosides Nucleotides* 9:123-127
- Bowen DJ, Webb CE, Peake IR, Bloom AL (1991) *AatII* polymorphism in von Willebrand factor gene at codon 471. *Nucleic Acids Res* 19:3159
- Budowle B, Chakraborty R, Giusti AW, Eisenberg AJ, Allen RC (1991) Analysis of the VNTR locus D1S80 by the PCR followed by high-resolution PAGE. *Am J Hum Genet* 48:137-144
- Cantell K, Hirvonen S, Kauppinen HL, Myllylä G (1981) Production of interferon in human leukocytes from normal donors with the use of Sendai virus. In: Pestka S (ed) *Interferons, part A*. Vol 78 in: Colowick SP, Kaplan NO (eds) *Methods in enzymology*. Academic Press, New York, pp 29-38
- Casanova JL, Pannetier C, Jaulin C, Kourilsky P (1990) Optimal conditions for directly sequencing double-stranded PCR products with Sequenase. *Nucleic Acids Res* 18:4028
- Chumakov PM, Jenkins JR (1991) *BstNI/NciI* polymorphism of the human p53 gene (TP53). *Nucleic Acids Res* 19:6969
- Collinge J, Palmer MS, Dryen AJ (1991) Genetic predisposition to iatrogenic Creutzfeldt-Jakob disease. *Lancet* 337:1441-1442
- DePachter-Holthuisen P, Van der Kammen RA, Jansen M, Van Schaik FMA, Sussenbach JS (1988) Differential expression of the human insulin-like growth factor II gene: characterization of the IGF-II mRNAs and an mRNA encoding a putative IGF-II-associated protein. *Biochim Biophys Acta* 950:282-295
- Diepstraten CM, Ploos van Amstel JK, Reitsma PH, Bertina RM (1991) A CCA/CCG neutral dimorphism in the codon for Pro 626 of the human protein S gene PS $\alpha$  (PROS1). *Nucleic Acids Res* 19:5091
- Edwards A, Civitello A, Hammond HA, Caskey CT (1991) DNA typing and genetic mapping with trimeric and tetrameric tandem repeats. *Am J Hum Genet* 49:746-756
- Fisher KL, FitzGerald GA, Lawn RM (1987) Two polymorphisms in the human lipoprotein lipase (LPL) gene. *Nucleic Acids Res* 15:7657
- Greenberg BD, Newbold JE, Sugino A (1983) Intraspacific nucleotide sequence variability surrounding the origin of replication in human mitochondrial DNA. *Gene* 21:33-49

- Gürtler H (1956) Principles of blood group statistical evaluations of paternity cases at the University Institute of Forensic Medicine, Copenhagen. *Acta Med Leg Soc (Liege)* 9: 83–93
- Helminen P, Sajantila A, Johnsson V, Lukka M, Ehnholm C, Peltonen L (1992) Amplification of three hypervariable DNA regions by polymerase chain reaction for paternity determinations: comparison with conventional methods and DNA fingerprinting. *Mol Cell Probes* 6:21–26
- Higuchi R (1989) Simple and rapid preparation of samples for PCR. In: Erlich HA (ed) *PCR technology—principles and applications for DNA amplification*. Stockton, New York, pp 31–39
- Higuchi R, von Beroldigen CH, Sensabaugh GF, Erlich HA (1988) DNA typing from single hairs. *Nature* 332:543–546
- Höög JO, Hedén LO, Larsson K, Jörnvall H, von Bahr-Lindström H (1986) The  $\gamma_1$  and  $\gamma_2$  subunits of human liver alcohol dehydrogenase cDNA structures, two amino acid replacements, and compatibility with changes in the enzymatic properties. *Eur J Biochem* 159:215–218
- Horn GT, Richards B, Merrill JJ, Klinger KW (1990) Characterization and rapid analysis of DNA polymorphisms closely linked to the cystic fibrosis locus. *Clin Chem* 36: 1614–1619
- Horn GT, Richards B, Wright G, Landes GM, Klinger KW (1989) Analysis and detection of genetic polymorphisms near the cystic fibrosis and Huntington's disease loci. *Human Gene Mapping 10. Cytogenet Cell Genet* 51:714, 855
- Jalanko A, Ranki M, Söderlund H (1992) Detection of four cystic fibrosis mutations with solid-phase minisequencing. *J Cell Biochem Suppl* 16F:12
- Jeffreys AJ, MacLeod A, Tamaki K, Neil DL, Monckton DG (1991) Minisatellite repeat coding as a digital approach to DNA typing. *Nature* 354:204–209
- Jeffreys AJ, Wilson V, Neumann R, Keyte J (1988) Amplification of human minisatellites by the polymerase chain reaction: towards DNA fingerprinting of single cells. *Nucleic Acids Res* 16:10953–10971
- Jeffreys AJ, Wilson V, Thein SL (1985) Hypervariable "minisatellite" regions in human DNA. *Nature* 314:67–73
- Jin WD, Desnick RJ, Schuchman EH (1991) A common polymorphism in the human arylsulfatase B (ARSB) gene at 5q13-q14. *Nucleic Acids Res* 19:4305
- Jones DA (1972) Blood samples: probability of discrimination. *J Forensic Sci Soc* 12:355–359
- Kasai K, Nakamura Y, White R (1990) Amplification of a variable number of tandem repeats (VNTR) locus (pMCT118) by the polymerase chain reaction (PCR) and its application to forensic science. *J Forensic Sci* 35:1196–1200
- Knott TJ, Pease RJ, Powell LM, Wallis SC, Rall SC Jr, Innerarity TL, Blackhart B, et al (1986) Complete protein sequence and identification of structural domains of human apolipoprotein B. *Nature* 323:734–738
- Kretzschmar HA, Stowring LE, Westaway D, Stubblebine WH, Prusiner SB, Dearmond SJ (1986) Molecular cloning of a human prion protein cDNA. *DNA* 5:315–324
- Lachance Y, Luu-The V, Labrie C, Simard J, Dumont M, De Launoit Y, Guérin S, et al (1990) Characterization of human  $3\beta$ -hydroxysteroid dehydrogenase/ $\Delta^5$ - $\Delta^4$ -isomerase gene and its expression in mammalian cells. *J Biol Chem* 265:20469–20475
- Leitersdorf E, Hobbs HH (1988) Human LDL receptor gene: HincII polymorphism detected by gene amplification. *Nucleic Acids Res* 16:7215
- Lukka M, Ehnholm C, Kuusi T (1985) Phosphoglucomutase (PGM<sub>1</sub>) subtypes in a Finnish population determined by isoelectric focusing in agarose gel. *Hum Hered* 35:95–100
- Lukka M, Turunen P, Kataja M, Ehnholm C (1986) Group-specific component (Gc): subtypes in the Finnish population: description of a new allele and an apparent mother-child incompatibility. *Hum Hered* 36:299–303
- Mancuso DJ, Tuley EA, Westfield LA, Worrall NK, Shelton-Inloes BB, Sorace JM, Alevy YG, et al (1989) Structure of the gene for human von Willebrand factor. *J Biol Chem* 264:19514–19527
- Misiura K, Durrant I, Evans MR, Gait MJ (1990) Biotinyl and phosphotyrosinyl phosphoramidite derivatives useful in the incorporation of multiple reporter groups on synthetic oligonucleotides. *Nucleic Acids Res* 18:4345–4354
- Mullis KB, Faloona F (1987) Specific synthesis of DNA in vitro via a polymerase-catalyzed chain reaction. In: Wu R (ed) *Recombinant DNA*, part F. Vol 155 in: Colowick SP, Kaplan NO (eds) *Methods in enzymology*. Academic Press, New York, pp 335–350
- Nevanlinna HR (1972) The Finnish population structure—a genetic and genealogical study. *Hereditas* 71:195–236
- (1980) Rare hereditary diseases and markers in Finland: an introduction. In: Erikson AW, Forsius HR, Nevanlinna HR, Workman PL, Norio RK (eds) *Population structure and genetic disorders*. Academic Press, New York, pp 569–576
- Nickerson DA, Kaiser R, Lappin S, Stewart J, Hood L, Landegren U (1990) Automated DNA diagnostics using ELISA-based oligonucleotide ligation assay. *Proc Natl Acad Sci USA* 87:8923–8927
- Oka K, Tkalcovic GT, Stocks J, Galton DJ, Brown WV (1989) Nucleotide sequence of PvuII polymorphic site at the human lipoprotein lipase gene locus. *Nucleic Acids Res* 17:6752
- Peters C, Schmidt B, Rommerskirch W, Rupp K, Zuehlsdorf M, Vingron M, Meyer HE, et al (1990) Phylogenetic conservation of arylsulfatases: cDNA cloning and expression of human arylsulfatase B. *J Biol Chem* 265:3374–3381

- Ploos van Amstel HK, Reitsma PH, Van der Logt CPE, Bertina RM (1990) Intron-exon organization of the active human protein S gene PS $\alpha$  and its pseudogene PS $\beta$ : duplication and silencing during primate evolution. *Biochemistry* 29:7853-7861
- Reynolds R (1991) The development of new PCR markers for the analysis of forensic evidence. *Crime Lab Dig* 18:132-133
- Rhéaume E, Sirois I, Labrie F, Simard J (1991) Codon 367 polymorphism of the human type I 3 $\beta$ -hydroxysteroid dehydrogenase/isomerase gene (HS5DB3). *Nucleic Acids Res* 19:6060
- Saiki RK, Walsh PS, Lewenson CH, Erlich HA (1989) Genetic analysis of amplified DNA with immobilized sequence-specific oligonucleotide probes. *Proc Natl Acad Sci USA* 86:6230-6234
- Sajantila A, Budowle B, Ström M, Johnsson V, Lukka M, Peltonen L, Ehnholm C (1992a) PCR amplification of alleles at the D1S80 locus: comparison of a Finnish and a North American Caucasian population sample, and forensic casework evaluation. *Am J Hum Genet* 50:816-825
- Sajantila A, Puomilahti S, Johnsson V, Ehnholm C (1992b) Amplification of reproducible allele markers for amplified fragment length polymorphism analysis. *BioTechniques* 12:16-22
- Soria LF, Ludwig EH, Clarke HRG, Vega GL, Grundy SM, McCarthy BJ (1989) Association between a specific apolipoprotein B mutation and familial defective apolipoprotein B-100. *Proc Natl Acad Sci USA* 86:587-591
- Stinissen P, Van Broeckhoven C (1991) PCR detection of the frequent Taq1 RFLP at locus D21S13E. *Nucleic Acids Res* 19:2516
- Sullivan KM, Hopgood R, Lang B, Gill P (1991) Automated amplification and sequencing of human mitochondrial DNA. *Electrophoresis* 12:17-21
- Syvänen A-C, Aalto-Setälä K, Harju L, Kontula K, Söderlund H (1990) A primer-guided nucleotide incorporation assay in the genotyping of apolipoprotein E. *Genomics* 8:684-692
- Syvänen A-C, Söderlund H, Laaksonen E, Bengtström M, Turunen M, Palotie A (1992) N-ras gene mutations in acute myeloid leukemia: accurate detection by solid-phase minisequencing. *Int J Cancer* 50:713-718
- Tadokoro K, Fujii H, Inoue T, Yamada M (1991) Polymerase chain reaction (PCR) for detection of Apal polymorphism at the insulin like growth factor II gene (IGF2). *Nucleic Acids Res* 19:6967
- Tanaka S, Kant J, Reed JC (1991) G to A polymorphism in the second exon of the BCL2 gene. *Nucleic Acids Res* 19:1964
- Tsujimoto Y, Croce CM (1986) Analysis of the structure, transcripts, and protein products of *bcl-2*, the gene involved in human follicular lymphoma. *Proc Natl Acad Sci USA* 83:5214-5218
- Walsh PS, Erlich HA, Higuchi R (1992) Preferential PCR amplification of alleles: mechanisms and solutions. *PCR Methods Appl* 1:241-250
- Xu Y, Carr LG, Bosron WF, Li TK, Edenberg HJ (1988) Genotyping of human alcohol dehydrogenases at the *ADH2* and *ADH3* loci following DNA sequence amplification. *Genomics* 2:209-214