

How F_0 -ATPase generates rotary torque

George Oster, Hongyun Wang and Michael Grabe

University of California, Berkeley, CA 94720-3112, USA

The F-ATPases synthesize ATP using a transmembrane ionmotive force (IMF) established by the electron transport chain. This transduction involves first converting the IMF to a rotary torque in the transmembrane F_0 portion. This torque is communicated from F_0 to the F_1 portion where the energy is used to release the newly synthesized ATP from the catalytic sites according to Boyer's binding change mechanism. Here we explain the principle by which an IMF generates this rotary torque in the F_0 ion engine.

Keywords: ATP synthase; molecular motors; mechanochemistry; Brownian ratchet; energy transduction; proton pumps

1. INTRODUCTION

According to Mitchell's chemiosmotic model (Mitchell 1979), energy stored in a transmembrane electrochemical gradient is converted into the chemical bond energy of ATP by the membrane protein ATP synthase. Implicit in Mitchell's model is the assumption that membrane potential and transmembrane ion gradients are thermodynamically equivalent:

$$\text{protonmotive force (PMF)} = (2.3RT/F) \times \Delta\text{pH} + \Delta\Psi, \quad (1)$$

where R is the gas constant, T the absolute temperature and F the Faraday constant. $\Delta\Psi$ is the transmembrane electrical potential.

Thus either one, or both, can drive the synthesis of ATP by the ATP synthases equally well. This view is reinforced by experiments showing that the chloroplast ATP synthase is driven almost completely by ΔpH , while the mitochondrial and bacterial ATP synthases operate on a combination of membrane potential and ΔpH . Recent experiments in Peter Dimroth's laboratory have shed doubt on the kinetic equivalence of the two components of PMF (Kaim & Dimroth 1998*a,b*, 1999; Dimroth *et al.* 1998).

The molecular explanation for how this energy transduction is carried out undoubtedly resides in the structure of ATP synthase. This protein consists of two portions: a soluble segment, called F_1 , attached to a transmembrane segment called F_0 —hence the alternate name F_0F_1 -ATPase. The structure of F_1 is now known to atomic detail (Abrahams *et al.* 1994; Stock *et al.* 1999) and, although no structure has yet been elucidated for F_0 , enough information is known to establish its overall geometry and identify the key amino acids required for its function (Dimroth *et al.* 1998; Fillingame *et al.* 1998*a,b*; Girvin *et al.* 1998; Jones & Fillingame 1998; Kaim *et al.* 1998; Matthey *et al.* 1999; Valiyaveetil & Fillingame 1998). The picture that has emerged is of a composite molecular machine consisting of two reversible rotary

motors attached to a common shaft. The F_1 motor can generate a rotary torque by using the hydrolysis of ATP, and the F_0 motor generates a rotary torque in the opposite direction using the transmembrane protonmotive force. When the F_0 motor is stronger, it drives the F_1 motor in reverse and ATP is synthesized. Conversely, when the F_1 motor is stronger, it drives the F_0 motor in reverse to pump ions up the electrochemical gradient. The structurally related vacuolar, V-ATPase, proton pumps are presumed to operate according to the same mechanochemical principles as the F-ATPases.

Several qualitative proposals have been proposed for the mechanism of energy transduction (Junge *et al.* 1997; Vik & Antonio 1994). We have formulated a mathematical model that can explain the quantitative behaviour of both the proton- and sodium-driven F_0 motors (Dimroth *et al.* 1999; Elston *et al.* 1998). Both models operate on the same physical principle, but differ in the geometric layout of the F_0 structure and the relative roles of the membrane potential and the pH gradient as driving forces. Here we will give a qualitative description of the basic operating principle by which cells convert electrochemical gradients into rotary motion. We will illustrate the mechanism using the sodium-driven F_0 motor of the anaerobic bacterium *Propionigenium modestum*.

2. TORQUE GENERATION IN THE SODIUM F-ATPASES

The overall geometry of the sodium driven F-ATPase of *P. modestum* is shown in figure 1; details can be found in Dimroth *et al.* (1999). For our purposes here we need only recognize that the entire structure can be subdivided into two counter-rotating assemblies denoted by convention as the 'rotor' and 'stator'. The rotor consists of 10–12 copies of the c-subunit arranged into a ring. Attached to this assembly is a 'shaft' consisting of the γ - and ϵ -subunits. The remainder of the protein consisting of subunits ($\text{ab}_2\delta\alpha_3\beta_3$) is the 'stator'.

Ions flow from the acidic reservoir (periplasm in figure 1) down the interface between the a subunit and the c_{12}

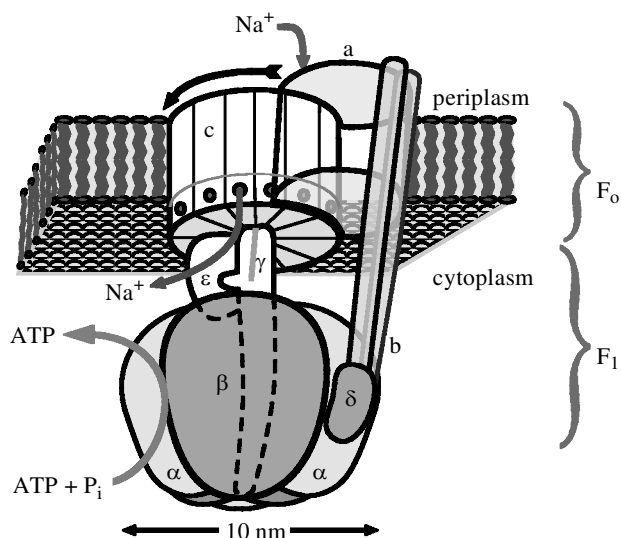

Figure 1. Cartoon showing the overall geometry of the sodium F_0 -ATPase of *Propionigenium modestum*. The rotor assembly consisting of $(c_{12}\gamma\epsilon)$ is shown in white and the stator assembly $(ab_2\beta\delta_3\alpha_3)$ is shaded.

assembly to the basic reservoir. The unique structure of this interface permits the F_0 motor to convert the trans-membrane ionmotive force into a rotary torque. To see how this works, we begin by examining the amino-acid sequence and putative topology of the a- and c-subunits shown in figure 2. The key feature of the c-subunit is that the ion-binding site consisting of Q32, E65 and S66 lies just below the membrane-spanning helices. Thus the sodium ions binding to the rotor are in contact with the cytoplasm.

The feature of note in the topology of the a-subunit stator is the polar residues that flank the essential basic residue Arg-227. The significance of this juxtaposition is shown in figure 3a, where we depict one possible structure for the stator consistent with the topology. To prevent ion leakage between the reservoirs, the entire rotor-stator interface is hydrophobic except for two regions: (i) a blind ion channel that leads from the periplasm to the level of the rotor sites; and (ii) a hydrophilic strip comprising the polar residues flanking Arg-227. This allows an unionized (charged) rotor site to rotate into the interface to the channel along the hydrophilic strip. The essential stator charge, Arg-227, blocks ions from leaking through this route to the cytoplasm. A rotor site having bound an ion from the channel can pass through the hydrophobic barrier and exit the stator, whereupon the site can discharge its ion to the cytoplasm. The path of ions is shown in the right panel of figure 3b.

How do ions flowing along this pathway generate a rotary torque? This involves constructing two sets of equations, one for the mechanical torque balance on the rotor and the other for the kinetics of ions binding and dissociating from each of the rotor sites that interact with the stator. Details of these calculations for the sodium F_0 motor can be found in Dimroth *et al.* (1999). Here we give a qualitative description of the motor operation using the free energy diagram in figure 4; however, to demonstrate that this scenario actually works one must do an honest calculation.

Because of the pK_a of the rotor's ion binding sites, a rotor site exposed to the cytoplasm is unlikely to be ionized. The rotational diffusion of the rotor eventually carries an unionized site into the hydrophilic strip at the right edge of the stator. Once inside, it is quickly captured by the Coulomb attraction of the stator charge, Arg-227. The captured site can escape by thermal fluctuations, but without the membrane potential it is equally as likely to escape in either direction. If the entrance channel is aqueous, the bulk of the potential drop will be across the hydrophilic strip. That is, the vertical voltage drop is rotated 90° so that the membrane potential now acts tangentially to the rotor. This tilts the free energy profile biasing the thermal escape of the rotor to the left in figure 4. A rotor site that fluctuates to the left cannot pass through the hydrophobic barrier that forms the left side of the channel, for this requires more than 25 kcal mol^{-1} ($45 k_B T$). However, once exposed to the periplasmic channel it will quickly pick up an ion. This neutralizes its charge and allows it to pass through the barrier easily when the next site diffuses into the stator and is captured by the stator charge. When the site emerges from the stator, it quickly loses its ion to the cytoplasm, and then cannot diffuse backwards into the stator. Thus the rotor is driven to the left in figure 4 by the biased diffusion induced by the membrane potential and the concentration difference between the periplasm and the cytoplasm. If some, or all, of the membrane potential drop occurs vertically down the periplasmic channel, the effect is to increase the effective ion concentration seen by each rotor site as it passes through the channel environment. This increases the probability that the site will be neutralized and so capable of passing the hydrophobic barrier.

Two questions remain: Can this mechanism generate enough torque to release ATP from the catalytic sites in F_1 ? What fractions of the torque are generated by the membrane potential and the concentration gradient? The relative contributions of the concentration difference and the membrane potential to the driving torque depend on the details of the rotor-stator interaction (Dimroth *et al.* 1999). To synthesize ATP at the measured rate of $30\text{--}50 \text{ s}^{-1}$, the motor must sustain a torque of $40\text{--}50 \text{ pN nm}$. Figure 5 shows a load-velocity curve for the sodium F_0 motor computed for the case when all the membrane potential drop takes place across the horizontal polar strip. In this case, the motor is able to generate sufficient torque to free ATP from F_1 . The assumptions and calculations underlying the curve computed in figure 5 are discussed in Dimroth *et al.* (1999). There are conditions under which the ion gradient contributes more equally to the motor torque; however, these conditions are at variance with other experimental observations on the sodium F_0 motor (Dimroth *et al.* 1999).

3. THE PROTON F_0 MOTOR

In contrast to the sodium F_0 -ATPase, in the proton F_0 -ATPases, there is evidence that the ion binding site on the rotor (D61 in *Escherichia coli*) is not accessible from the cytoplasm as it is in the sodium motor (Girvin *et al.* 1998; Jones *et al.* 1998; Long *et al.* 1998). To accommodate this difference it is necessary to assume that the stator has two aqueous half-channels, one communicating with the acid

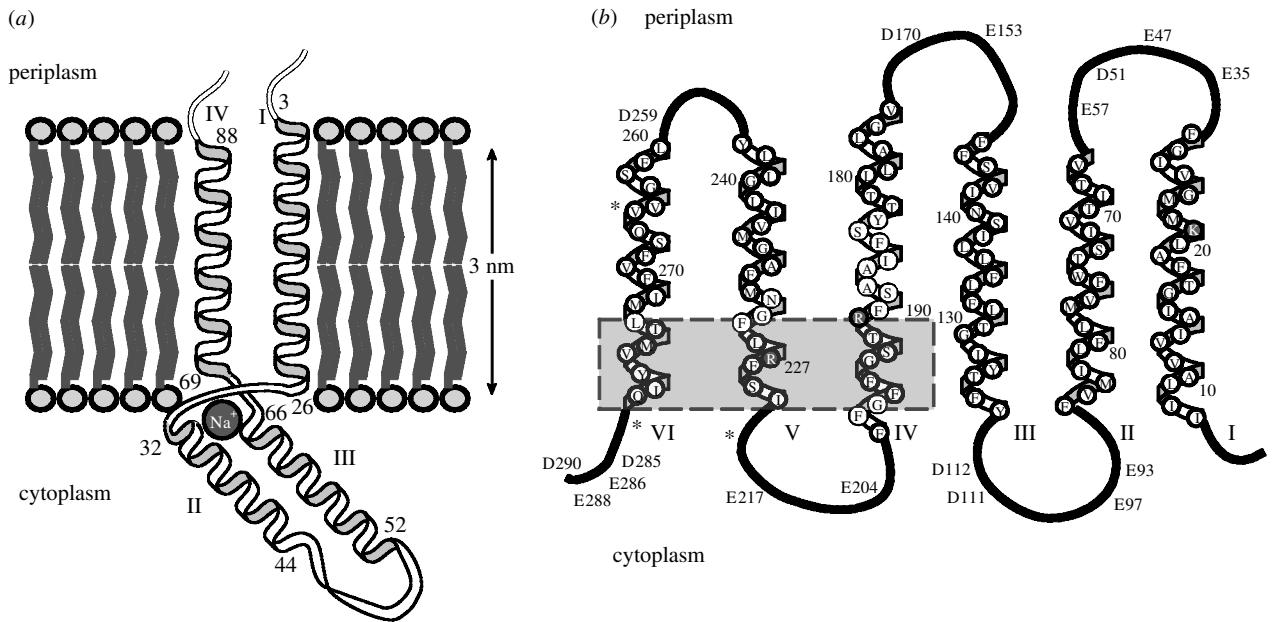

Figure 2. The sequence and putative topology of the (a) c- and (b) a-subunits for the sodium F_0 motor (redrawn from Matthey *et al.* (1999) and P. Dimroth (personal communication)). The ion-binding site on the c-subunit is located below the level of the membrane. The essential basic charge (R227) on the a-subunit is flanked by polar hydrophilic residues.

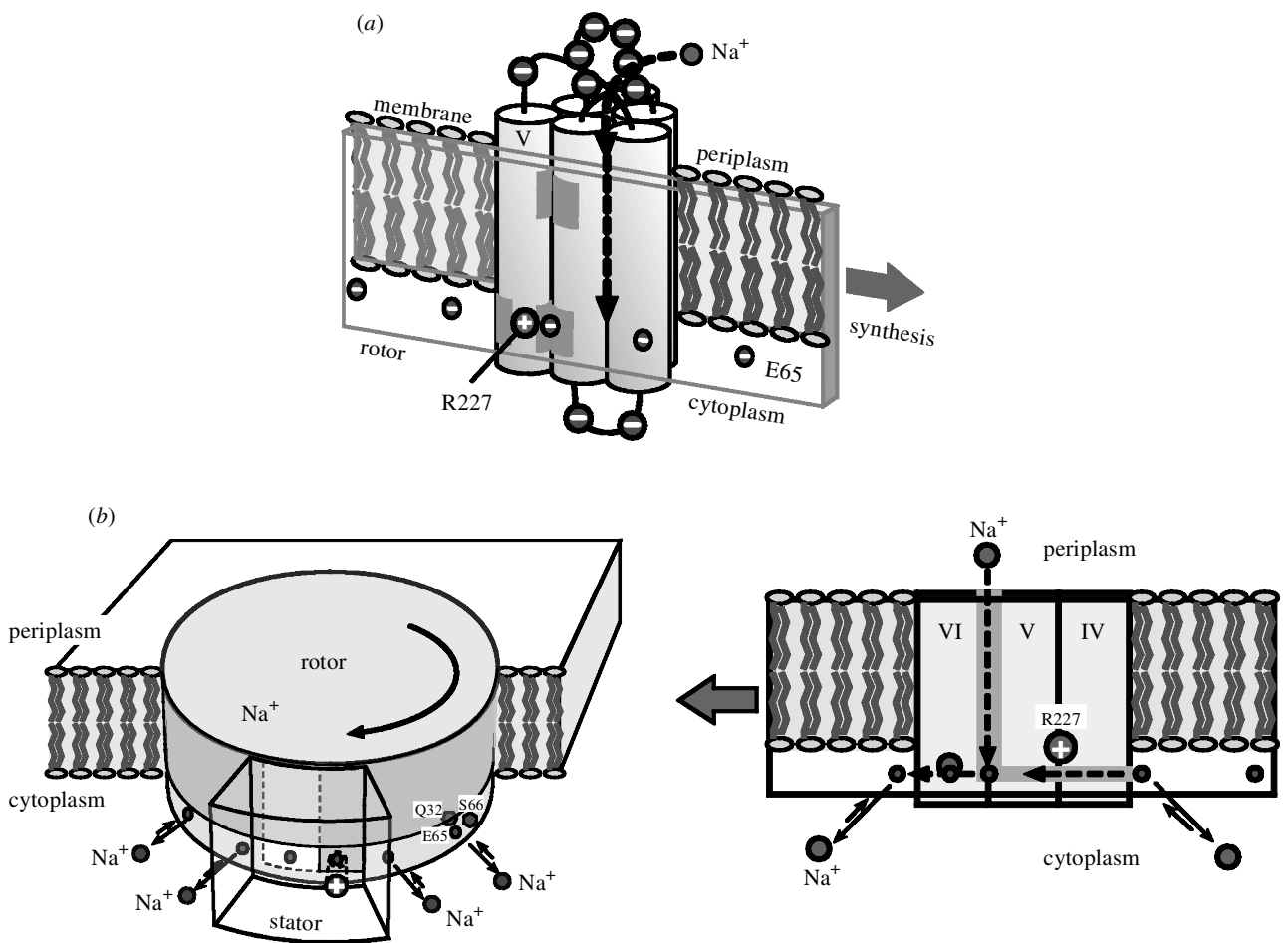

Figure 3. (a) Proposed structure for the rotor-stator assembly. An unoccupied rotor ion-binding site can enter the rotor-stator interface along the hydrophilic strip as far as the channel connecting to the periplasmic reservoir. (b) Left panel, schematic of the rotor-stator assembly. The rotor ion-binding sites (E65) are in equilibrium with the cytoplasmic reservoir. The stator basic site (R227) is located close to the polar strip through which the rotor sites pass. The half-channel connects the periplasm to the rotor sites. Right, face-on view of the rotor-stator assembly. Rotation of the c_{12} assembly carries an unoccupied site into the stator interface where it picks up an ion from the aqueous channel connecting to the periplasmic reservoir. Thus neutralized, it can continue to rotate out of the interface until the site is in contact with the cytoplasmic reservoir.

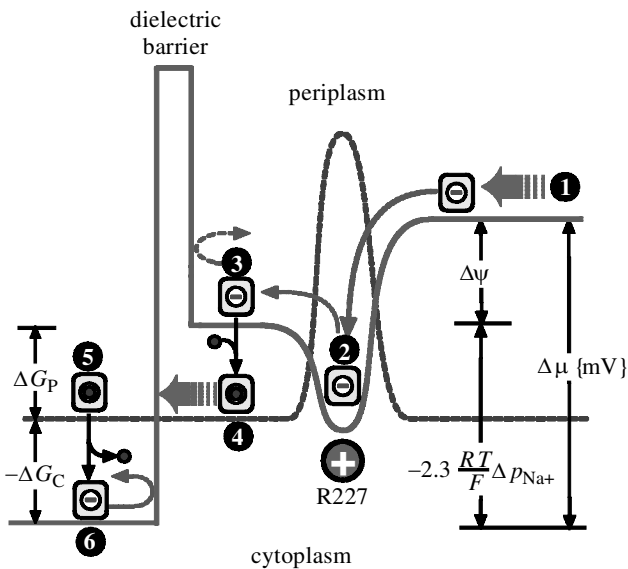

Figure 4. Free energy diagram following a rotor site as it passes through the stator. The total ionmotive force between the periplasm and the cytoplasm is $\Delta\mu = \Delta\Psi - 2.3(RT/F)\Delta\text{pH}$ (equation 1). The solid curve is the free energy seen by an unoccupied (negatively charged) rotor site. The dashed curve is the free energy curve seen by an occupied (neutral) rotor site. The sequence of events as a rotor site passes through the stator is as follows. (i) An unoccupied (charged) rotor site diffuses into the rotor–stator interface along the hydrophilic strip. (ii) The site is captured by the stator positive charge (Arg-227) and pulled into its Coulomb potential well. (iii) The membrane potential, $\Delta\Psi$, acts across the horizontal strip. This tilts the potential curve to the left and lowers the left edge of the Coulomb well. This makes it much more likely that the rotor site will escape via thermal fluctuations to the left. However, it cannot pass the hydrophobic barrier that forms the left edge of the channel. (iv) Diffusion of the site into the ion channel permits it to pick up an ion from the channel. This drops the site on to the dashed potential corresponding to the neutralized state. (v) Neutralized, it no longer sees the hydrophobic barrier and can diffuse to the left. Its motion is aided by the capture on the next rotor site by the stator charge, which pulls the rotor to the left. (vi) Emerging from the hydrophobic stator interface, the rotor site loses its ion to the cytoplasm. Now charged, it cannot diffuse backwards across the hydrophobic barrier, so the thermal motion to the left is ratcheted.

reservoir and the other with the basic reservoir. Protons board the rotor from the acid channel and rotate almost a complete revolution before dissociating into the basic reservoir. Previously, we showed that a rotor–stator assembly with this geometry could generate sufficient torque to synthesize ATP using a proton gradient alone (Elston *et al.* 1998). Previous qualitative models of the F_0 motor were based on the notion of a ‘Brownian ratchet’ (Peskin *et al.* 1993) wherein rotary diffusion was somehow rectified by the ion flow through the protein (Junge *et al.* 1997; Vik & Antonio 1994). Our analysis has shown that this mechanism alone cannot account quantitatively for the torque required for ATP synthesis. However, if a membrane potential is added to the proton F_0 model in the same way as in the sodium F_0 model, then the principle of operation is the same in both geometries: electrostatic forces bias the rotational diffusion of the rotor.

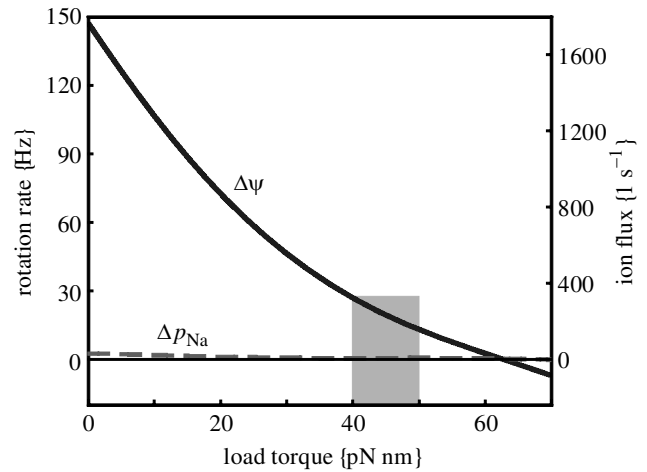

Figure 5. The load–velocity curve for the sodium V_0 motor. The range of torques required for ATP synthesis is shown by the shaded band. Under normal operating conditions almost all of the torque is due to the membrane potential (solid curve). The same ionmotive force in the form of a transmembrane sodium gradient generates very little torque (dashed curve).

Deciding which rotor–stator geometry is correct awaits further experiments; however, the operating principle is the same in both models with one half-channel and two half-channel geometries.

4. RUNNING IN REVERSE: THE V-ATPASE PROTON PUMPS

The mechanical behaviour of the F_1 motor has been measured (Yasuda *et al.* 1998) and its mechanochemical mechanism modelled (Wang & Oster 1998). No equivalent measurements have been performed yet on the F_0 motor. However, there is one crucial requirement of any purported mechanism for the F_0 motor: it must be capable of reversing to perform as an ion pump, for in bacteria, ATP synthase does just this under anaerobic conditions. Indeed, the structurally similar V-ATPases are presumed to have evolved from the F-ATPases (Taiz & Nelson 1996). Therefore, we can look for experimental confirmation of the model by examining its ion-pumping behaviour when torque is applied to the rotor to reverse its direction.

Despite their geometric similarities, the V-ATPases have several modifications that indicate their specialization for pumping. Aside from various regulatory subunits (V-ATPases typically have more ‘parts’ than F-ATPases), the most important structural difference is in the c-subunits. Whereas the F_0 c-subunit is a double α -helix and assembles into a c_{12} -cylinder with 12 proton-binding sites, the V_0 c-subunit consists of four α -helices assembled into a c_6 -cylinder with only six proton-binding sites. This downshift in ‘gear ratio’ enables the V-ATPases to pump to much lower pH values than their F_0 relatives. ATP hydrolysis in V_1 is converted into torque on the rotor. Figure 6a shows the proton pathway through the stator in the pumping mode. Protons are picked up in the cytoplasm and moved across the hydrophobic barrier into the channel facing the lumen. As the site approaches the stator charge, its pK_a is lowered and the site relinquishes

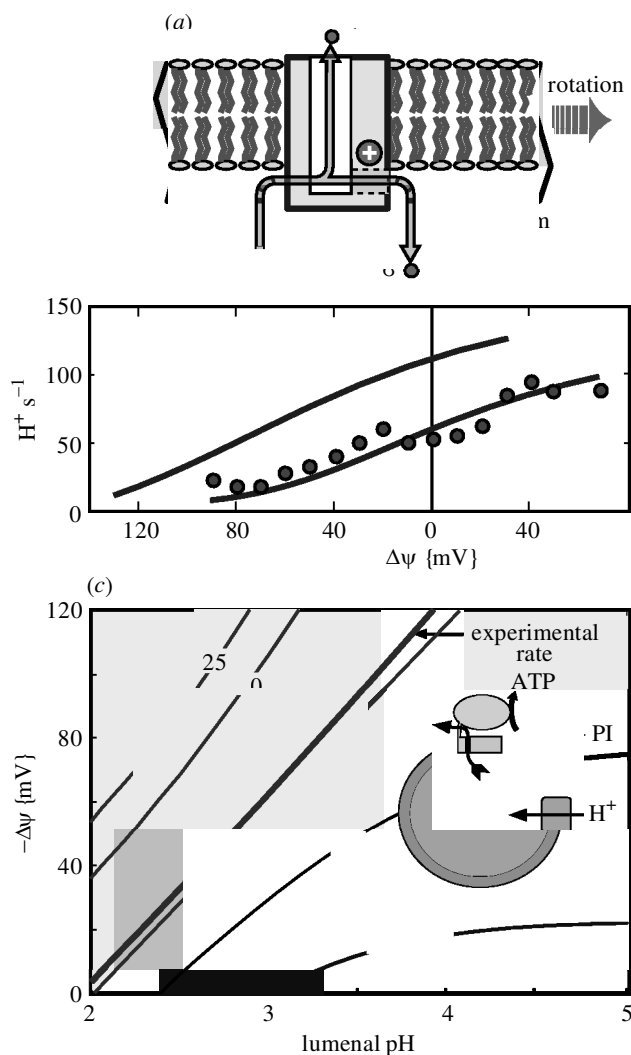

Figure 6. (a) The V-ATPase model based on the F_0 motor model by reducing the number of rotor sites from 12 to six and applying a torque to the rotor corresponding to the torque generated in V_1 by nucleotide hydrolysis. The proton path during pumping is shown by the arrow. An unprotonated site cannot enter the stator because of the hydrophobic barrier. However, once protonated, the site is rotated into the luminal channel. As it approaches the stator charge its pK_a is lowered and it releases its proton into the channel. As the luminal pH decreases, the rotor site may carry a proton to the right and release it back into the cytoplasm. The fraction of such events is σ , called the 'slip'. (b) Measured current voltage curves for V-ATPase. The data are from (Gambale *et al.* 1994) (filled triangles) and Davies (filled circles); the solid lines are computed from the model (Grabe *et al.* 2000). (c) In experiments by Yokoyama *et al.* (1998), vesicles acidified by bacteriorhodopsin could drive the V-ATPase in reverse to synthesize ATP. The region of synthesis is shown as shaded, and the experimentally measured rate is shown by the heavy line.

its proton to the luminal channel. A complete quantitative description of the V-ATPase model is given in Grabe *et al.* (2000). Figure 6b shows that the model fits well measured current–voltage data from several laboratories (more such graphs are presented in Grabe *et al.* (2000)). Further support for the model is provided by recent experiments that show for the first time that, exposed to extremely high ionmotive gradients, the V-ATPase can be

reversed to synthesize ATP. Figure 6c shows that the model can produce the torque required to produce the observed synthesis rates.

5. DISCUSSION

The F_0 motor illustrates a simple principle by which cells convert energy stored in a transmembrane ion gradient into a mechanical torque. Positive ions hop between acidic residues to cross the protein. At each hop, the local electrostatic field is altered, which produces either an electrostatic force between the rotor and stator, or an electrostatic barrier to back-rotation.

The idea of 'alternating potentials' driving unidirectional motion has attracted attention in the recent physics literature (Elston & Doering 1996; Parmeggiani *et al.* 1999; Peskin *et al.* 1993). For the most part, these studies have focused on general principles whose relationship to biology has been only suggestive. To connect this principle to particular biological phenomena requires a study of each structure. Here we have used the F_0 motor as a concrete setting for this principle. In the F_0 motor, each rotor ion-binding site sees two alternating potentials corresponding to the charged and neutralized states. Ions hopping on to the rotor from the periplasmic channel and off the rotor into the luminal reservoir create the switch between the two potentials.

Of course, the mechanism proposed here cannot function without thermally driven fluctuations; however, electrical forces play an essential role in driving the motor in two ways. First, the biasing of the rotor diffusion is accomplished by the dissociation of ions from the rotor sites, which leave them charged. In this state they see the stator boundary as a substantial hydrophobic barrier. Second, the membrane potential biases the diffusion of the rotor so that its thermally excited fluctuations carry it consistently in one direction. Electrical forces are also essential when the motor is driven in reverse to pump ions, either sodium or protons. In this mode, the Coulomb repulsion from the essential stator charge drives the ion off the rotor site into the luminal channel (Grabe *et al.* 2000). Thus the F_0 motor generates torque by both rectified diffusion and a 'power stroke' generated by the membrane potential.

Note added in proof. Since submission of the manuscript, J. Walker's laboratory has obtained a structure for the F_0 subunit of the bovine mitochondrial ATP synthase (Stock *et al.* 1999). There they report that the c-rotor consists of ten subunits, versus the usually quoted number of 12. This appears to require a non-integer number of protons per ATP synthesized. However, because of the elastic coupling between F_0 and F_1 , there is no requirement that the number of protons per ATP be integer, and so the principle of operation of the F_0 motor described herein remains unchanged (Oster & Wang 2000).

The authors were supported by a National Science Foundation grant no. DMS 9220719.

REFERENCES

- Abrahams, J., Leslie, A., Lutter, R. & Walker, J. 1994 Structure at 2.8 Å resolution of F_1 -ATPase from bovine heart mitochondria. *Nature* **370**, 621–628.

- Davies, J. M., Hunt, I. & Sanders, D. 1994 Vacuolar H⁺-pumping ATPase variable transport coupling ratio controlled by pH. *Proc. Natl Acad. Sci. USA* **91**, 8547–8551.
- Dimroth, P., Kaim, G. & Matthey, U. 1998 The motor of the ATP synthase. *Biochim. Biophys. Acta* **1365**, 87–92.
- Dimroth, P., Wang, H., Grabe, M. & Oster, G. 1999 Energy transduction in the sodium F-ATPase of *Propionigenium modestum*. *Proc. Natl Acad. Sci. USA* **96**, 4924–4929.
- Elston, T. & Doering, C. R. 1996 Numerical and analytical studies of nonequilibrium fluctuation-induced transport processes. *J. Stat. Phys.* **83**, 359–383.
- Elston, T., Wang, H. & Oster, G. 1998 Energy transduction in ATP synthase. *Nature* **391**, 510–514.
- Fillingame, R., Jones, P., Jiang, W., Valiyaveetil, F. & Dmitriev, O. 1998a Subunit organization and structure in the F₀ sector of *Escherichia coli* F₁F₀ ATP synthase. *Biochim. Biophys. Acta* **1365**, 135–142.
- Fillingame, R. H., Girvin, M. E., Jiang, W., Valiyaveetil, F. & Hermolin, J. 1998b Subunit interactions coupling H⁺ transport and ATP synthesis in F₁F₀ ATP synthase. *Acta Physiol. Scand.* **163**, 163–168.
- Gambale, F., Kolb, H., Cantu, A. & Hedrich, R. 1994 The voltage-dependent H⁺-ATPase of the sugar beet vacuole is reversible. *Eur. Biophys. J.* **22**, 399–403.
- Girvin, M., Rastogi, V., Abildgaard, F., Markley, J. & Fillingame, E. 1998 Solution structure of the transmembrane H⁺-transporting subunit c of the F₁F₀ ATP synthase. *Biochemistry* **37**, 8817–8824.
- Grabe, M., Wang, H. & Oster, G. 2000 The mechanochemistry of the V-ATPase proton pumps. *Biophys. J.* (In the press.)
- Jones, P. & Fillingame, R. H. 1998 Genetic fusions of subunit c in the F₀ sector of H⁺-transporting ATP synthase—functional dimers and trimers and determination of stoichiometry by cross-linking analysis. *J. Biol. Chem.* **273**, 29701–29705.
- Jones, P., Jiang, W. & Fillingame, R. 1998 Arrangement of the multicopy H⁺-translocating subunit c in the membrane sector of the *Escherichia coli* F₁F₀ ATP synthase. *J. Biol. Chem.* **273**, 17178–17185.
- Junge, W., Lill, H. & Engelbrecht, S. 1997 ATP synthase: an electro-chemical transducer with rotatory mechanics. *Trends Biochem. Sci.* **22**, 420–423.
- Kaim, G. & Dimroth, P. 1998a ATP synthesis by the F₁F₀ ATP synthase of *Escherichia coli* is obligatorily dependent on the electric potential. *FEBS Lett.* **434**, 57–60.
- Kaim, G. & Dimroth, P. 1998b Voltage-generated torque drives the motor of the ATP synthase. *EMBO J.* **17**, 5887–5895.
- Kaim, G. & Dimroth, P. 1999 ATP synthesis by F-type ATP synthase is obligatorily dependent on the transmembrane voltage. *EMBO J.* **18**, 4118–4127.
- Kaim, G., Matthey, U. & Dimroth, P. 1998 Mode of interaction of the single a subunit with the multimeric c subunits during the translocation of the coupling ions by F₁F₀ ATPases. *EMBO J.* **17**, 688–695.
- Long, J. C., Wang, S. & Vik, S. B. 1998 Membrane topology of subunit a of the F₁F₀ ATP synthase as determined by labeling of unique cysteine residues. *J. Biol. Chem.* **273**, 16235–16240.
- Matthey, U., Kaim, G., Braun, D., Wüthrich, K. & Dimroth, P. 1999 NMR studies of subunit c of the ATP synthase from *Propionigenium modestum* in dodecylsulfate micelles. *Eur. J. Biochem.* **261**, 459–467.
- Mitchell, P. 1979 Keilin's respiratory chain concept and its chemiosmotic consequences. *Science* **206**, 1148–1159.
- Oster, G. & Wang, H. 2000 Reverse engineering a protein: the mechanochemistry of ATP synthase. *Biochim. Biophys. Acta (Bioenergetics)* **1458**(special issue), 1–30.
- Parmeggiani, A., Julicher, F., Ajdari, A. & Prost, J. 1999 Energy transduction of isothermal ratchets: generic aspects and specific examples close to and far from equilibrium. *Phys. Rev. E.* (In the press.)
- Peskin, C. S., Odell, G. M. & Oster, G. 1993 Cellular motions and thermal fluctuations: the Brownian ratchet. *Biophys. J.* **65**, 316–324.
- Stock, D., Leslie, A. & Walker, J. 1999 Molecular architecture of the rotary motor in ATP synthase. *Science* **286**, 1700–1705.
- Taiz, L. & Nelson, N. 1996 Evolution of V- and F-ATPases. In *Origin and evolution of biological energy conversion* (ed. H. Baltscheffsky), pp. 291–305. New York: VCH Publishers.
- Valiyaveetil, F. & Fillingame, R. 1998 Transmembrane topography of subunit a in the *Escherichia coli* F₁F₀ ATP synthase. *J. Biol. Chem.* **273**, 16241–16247.
- Vik, S. B. & Antonio, B. J. 1994 A mechanism of proton translocation by F₁F₀ ATP synthases suggested by double mutants of the a subunit. *J. Biol. Chem.* **269**, 30364–30369.
- Wang, H. & Oster, G. 1998 Energy transduction in the F₁ motor of ATP synthase. *Nature* **396**, 279–282.
- Yasuda, R., Noji, H., Kinoshita, K. & Yoshida, M. 1998 F₁-ATPase is a highly efficient molecular motor that rotates with discrete 120° steps. *Cell* **93**, 1117–1124.
- Yokoyama, K., Munezaki, E., Amano, T., Mizutani, S., Yoshida, M., Ishida, M. & Ohkuma, S. 1998 V-ATPase of *Thermus thermophilus* is inactivated during ATP hydrolysis but can synthesize ATP. *J. Biol. Chem.* **273**, 20504–20510.

Discussion

L. Cruzeiro-Hansson (*Department of Mathematics, Heriot-Watt University, Edinburgh, UK*). There is another way of getting 100% efficiency in energy transfer, namely, by vibrational excited states. It is a resonant mechanism and so it does not dissipate energy. What ATP hydrolysis and ligand binding can do is create vibrational excited states.