

ORIGINAL ARTICLE

Validation of a field test for the non-invasive determination of badminton specific aerobic performance

M Wonisch, P Hofmann, G Schwabegger, S P von Duvillard, W Klein

Br J Sports Med 2003;37:115–118

See end of article for authors' affiliations

Correspondence to:
Dr Wonisch, Department of Internal Medicine, University of Graz, Auenbruggerplatz 15, A-8036 Graz, Austria; manfred.wonisch@uni-graz.at

Accepted 8 July 2002

Aim: To develop a badminton specific test to determine on court aerobic and anaerobic performance. **Method:** The test was evaluated by using a lactate steady state test. Seventeen male competitive badminton players (mean (SD) age 26 (8) years, weight 74 (10) kg, height 179 (7) cm) performed an incremental field test on the badminton court to assess the heart rate turn point (H RTP) and the individual physical working capacity (PWC_i) at 90% of measured maximal heart rate (HR_{max}). All subjects performed a 20 minute steady state test at a workload just below the PWC_i. **Results:** Significant correlations ($p < 0.05$) for Pearson's product moment coefficient were found between the two methods for HR ($r = 0.78$) and velocity ($r = 0.93$). The HR at the PWC_i (176 (5.5) beats/min) was significantly lower than the H RTP (179 (5.5) beats/min), but no significant difference was found for velocity (1.44 (0.3) m/s, 1.38 (0.4) m/s). The constant exercise test showed steady state conditions for both HR (175 (9) beats/min) and blood lactate concentration (3.1 (1.2) mmol/l). **Conclusion:** The data indicate that a valid determination of specific aerobic and anaerobic exercise performance for the sport of badminton is possible without H RTP determination.

The development of appropriate fitness tests is considered an essential task of exercise scientists.¹ Incremental exercise tests in the laboratory are commonly used to determine exercise performance of athletes and the appropriate training intensity to elicit the optimal aerobic and anaerobic capacity. A limitation of exercise tests conducted within the laboratory is that it is nearly impossible to design an assessment that can reflect the specific muscular involvement and movement patterns of a particular sport. This is particularly true for racket games because it is virtually impossible to emulate game-like conditions in the laboratory.

The physiological demands of badminton match play have been reported by several authors.^{2–6} The game may be characterised as high intensity intermittent exercise with a work/rest ratio of about 1:2 and having considerable stress on the cardiovascular system.⁴ Docherty² reported a mean duration of about five seconds per rally for badminton players of different skill levels. Therefore we suggest that anaerobic alactic metabolism may play a dominant role in a single rally. With respect to multiple bouts of high intensity exercise during a badminton game, the recovery of the creatine phosphate pool may be a limiting factor. Because the recovery of creatine phosphate has been shown to be strongly dependent on maximum oxygen consumption,⁷ a higher aerobic performance may be beneficial for these athletes.⁸ In addition to physical fitness, numerous other factors contribute to successful badminton playing, including technical and tactical skill, psychological preparation, and game strategy.^{9–10}

A specific fitness test for badminton players has been described by Chin *et al*¹¹ and Coen *et al*.¹¹ They reported that a badminton specific test is necessary to assess the metabolic and physiological demands of the sport. Chin *et al*¹¹ found a correlation ($r = 0.65$) between the results of a badminton specific field test and the rank order of the subjects, based on an objective field physiological assessment and subjective ranking by the trainers. In further support of this finding, the results of sport specific testing in squash were better related to the participants' rank order, which was established by the coach, than non-specific exercise testing in the laboratory.¹

Although the anaerobic threshold (AT) determined from incremental exercise tests is often used, most effort is expended in attainment of the maximal lactate steady state (MLSS). The MLSS is defined as the maximal exercise intensity consistent with the steady state blood lactate concentrations during the last 20 minutes of exercise.¹² Several steady state exercise tests are necessary for the determination of the MLSS.¹³ As this procedure is time consuming and technologically demanding, several investigators have attempted to determine the MLSS from a single incremental test.^{13–15}

A non-invasive approach to determining the AT has been presented by Conconi *et al*,¹⁶ using an incremental field test for runners. They found that the deflection of the heart rate (HR) near the maximal heart rate (HR_{max}) was significantly related to the AT.^{16–17} This concept has been investigated extensively,^{18–24} and from these studies one may conclude that the power output at the so called "heart rate threshold" or heart rate turn point (H RTP) reflects the MLSS.^{19–20} The incremental test protocol used by Conconi *et al*¹⁶ has been modified for several sports^{17–21} as well as for different laboratory conditions,^{17–18–22} but not for sports with a high level of technical skill such as badminton.

The difficulty associated with the determination of the H RTP and the causal relation to the AT have been addressed.²³ However, the determination of a physical working capacity (PWC) at a workload corresponding to a fixed percentage of the HR_{max} is always possible. Moreover, the objectivity is high because of a simple analysis under normal testing procedures.¹⁵ The purposes of this study were to: (a) develop a simple, badminton specific test to determine the AT; (b) determine the individual PWC (PWC_i); (c) compare PWC_i with H RTP; (d) assess the PWC_i by using a lactate steady state test.

Abbreviations: AT, anaerobic threshold; MLSS, maximal lactate steady state; HR, heart rate; HR_{max}, heart rate maximum; H RTP, heart rate turn point; PWC_i, individual physical working capacity; LA, blood lactate concentration

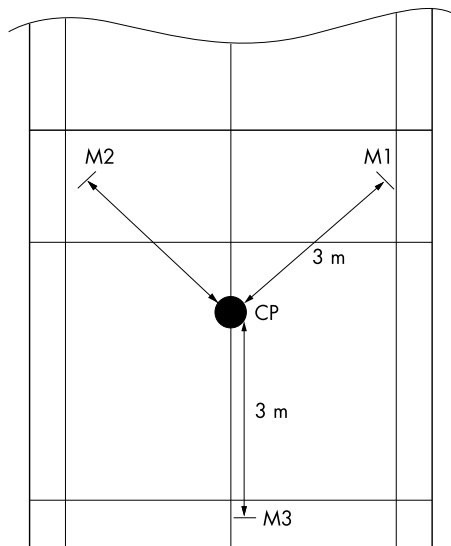

Figure 1 Badminton specific field test. CP, Central point; M1–3, markers.

Table 1 Mean heart rate (HR) and velocity at individual physical working capacity (PWC_i), heart rate turn point (HRTp), and maximal values as well as lactate values (LA) at the end of the badminton field test

	Maximal	HRTp	PWC_i
HR (beats/min)	195 (6)	179 (5.5)	176 (5.5)
Velocity (m/s)	2.20 (0.2)	1.44 (0.3)	1.38 (0.4)
LA (mmol/l)	7.6 (2.1)	–	–

Values are mean (SD) ($n = 16$).

SUBJECTS AND METHODS

Seventeen male national and international badminton players (mean (SD) age 26 (8) years, body weight 74 (10) kg, height 179 (7) cm) gave their written informed consent to participate in this study. The institutional ethics committee of the University of Graz approved the study. All testing was performed within one week. Subjects were instructed to eat their usual meals and not to engage in strenuous activity the day before testing.

Badminton specific incremental test

All subjects performed an incremental field test using the modified Conconi test¹⁶ in one half of the badminton court (singles court) to assess the heart rate performance curve (fig 1).

From a central point subjects started with a signal given by a whistle, moved 3 m forward to a marker at the right side of the court, touched the net with the racket, and moved immediately back to the central point. On the next signal, subjects moved to a second marker at the left side of the court and back again. Then they moved backwards to a third marker 3 m behind the central point performing a jump turn along the centre line carrying out a simulated smash. After they had returned to the central point, the procedure was repeated. Signals were given from a pacer (pocket computer; Sharp PC 1401, Osaka, Japan). Velocity at the beginning of the test was 0.60 m/s according to six signals per minute. The velocity was increased every minute by 0.10 m/s according to one signal per minute. The test was performed continuously until voluntary exhaustion. HR was measured continuously (Sporttester PE 4000; Polar Electro, Oy, Finland) and values stored in five second intervals. Capillary blood samples (20 μ l) were taken from

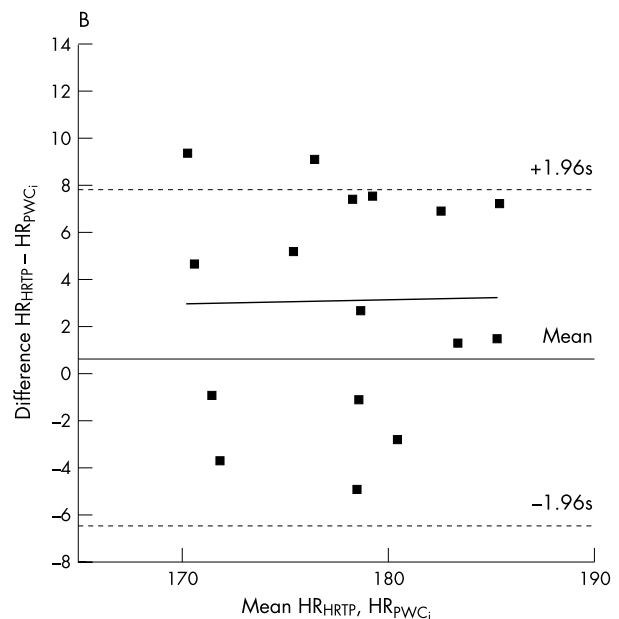
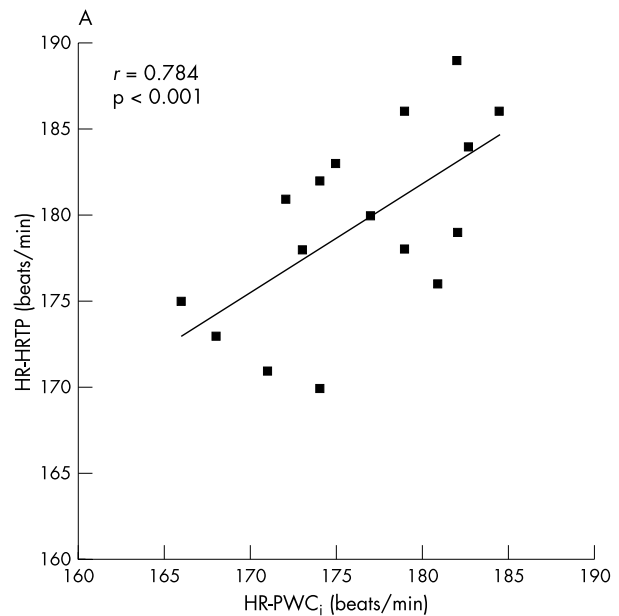

Figure 2 (A) Correlation between heart rate at individual physical working capacity ($HR-PWC_i$) and heart rate turn point ($HR-HRTp$) ($n = 16$). (B) Plot of difference against mean heart rate at individual physical working capacity ($HR-PWC_i$) and heart rate turn point ($HR-HRTp$) ($n = 16$).

the hyperaemic ear lobe at the beginning and within one minute of the end of the exercise for enzymatic determination of blood lactate concentration (LA) using an Eppendorf EBIO plus lactate analyser (Eppendorf, Hamburg, Germany).

The HRTp was assessed by computer aided linear regression break point analysis.¹⁸ The PWC_i at 90% of the measured HR_{max} was calculated by linear interpolation.

Lactate steady state test

After a rest period of at least 24 hours, the subjects performed one steady state test of 20 minutes duration at an intensity set at the PWC_i minus 0.03 m/s. The reduction in velocity was necessary because of the fixed interval of the pacer system (even number of movements/minute). HR was measured continuously, and load was terminated for 30 seconds to determine LA every five minutes.

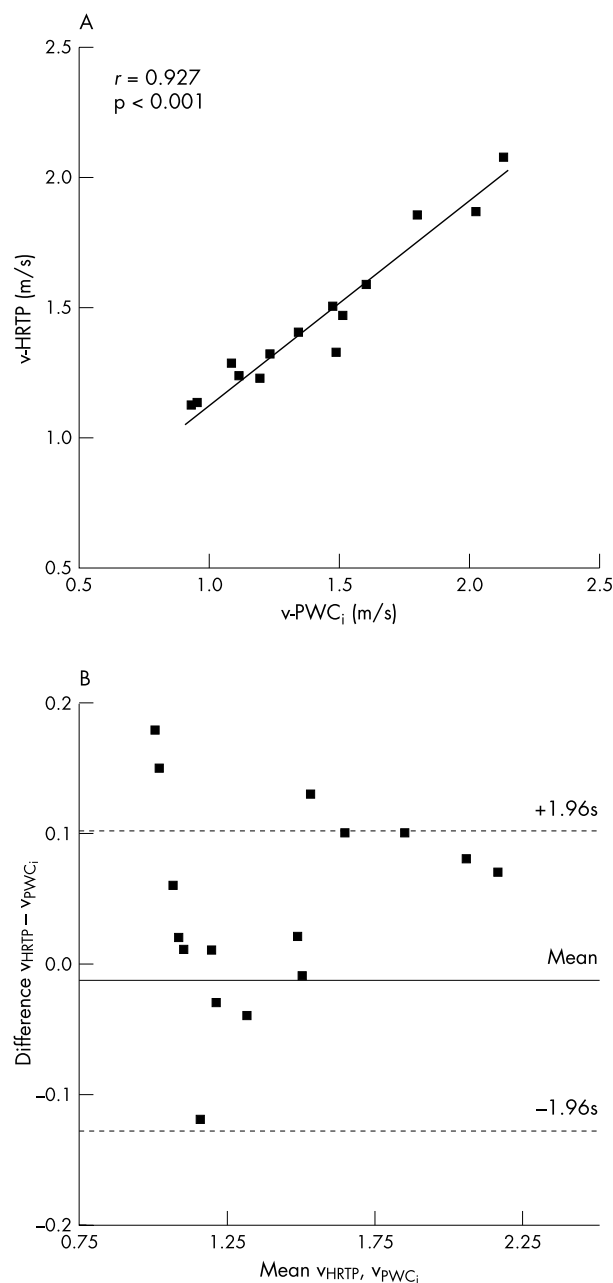

Figure 3 (A) Correlation of velocity at individual physical working capacity ($v\text{-PWC}_i$) and heart rate turn point ($v\text{-HRTP}$) ($n = 16$). (B) Plot of difference against mean velocity at physical working capacity (v_{PWC_i}) and heart rate turn point (v_{HRTP}) ($n = 16$).

Statistical analysis

Values are expressed as mean (SD). Pearson's product moment correlation coefficients were calculated. Paired t tests were used to determine significant differences between measured variables. Differences were plotted against the mean for HR and velocity at the HRTP and PWC_i , as suggested by Bland and Altman.²⁵ $p < 0.05$ was considered significant.

RESULTS

Badminton specific incremental test

The HRTP was successfully determined in 16 of the 17 subjects. Table 1 shows the data for HR, workload expressed as velocity, and LA from the incremental badminton field test.

Significant correlations ($p < 0.001$) were found between the PWC_i and the HRTP for HR ($r = 0.78$; fig 2A) and velocity ($r = 0.93$; fig 3A). The HR at the PWC_i was slightly but significantly

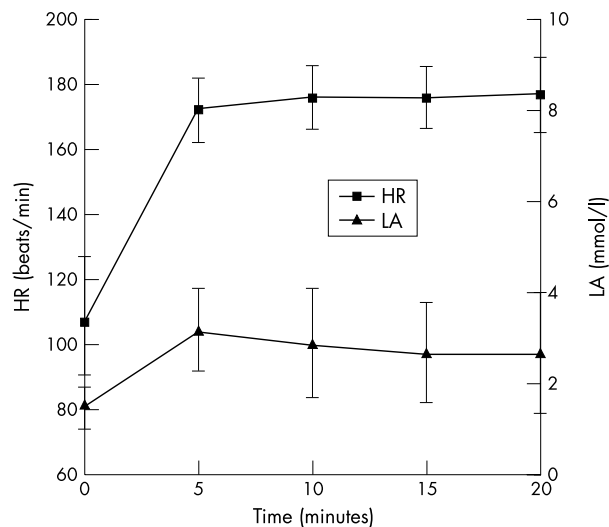

Figure 4 Mean heart rate (HR) and blood lactate concentration (LA) during the steady state test on the badminton court performed 0.03 m/s below the workload of the physical working capacity at 90% of HR_{max} ($n = 16$).

lower than that at the HRTP, but no significant differences were found between the two methods for velocity. Figure 2B shows the Bland-Altman plot for HR (mean difference 3.1 beats/min (95% confidence interval -6.2 to 12.4)). Figure 3B shows the Bland-Altman plot for velocity (mean difference 0.04 m/s (95% confidence interval -0.11 to 0.2)).²⁵

Lactate steady state test

All subjects reached steady state conditions for both HR and LA. Figure 4 shows the mean LA and HR values obtained from the steady state test. The mean (SD) values for LA and HR of the last minute of each step were 3.1 (1.2) mmol/l and 175 (9) beats/min respectively. The mean value obtained for the HR represented 88.9% of HR_{max} calculated from the incremental test. All steady state HRs were significantly lower than HR at the HRTP. No differences were found between steady state HR and HR at PWC_i .

DISCUSSION

The results of this study indicate that the incremental badminton specific field test was similar for the HRTP and PWC_i methods. Although a slight difference between velocity at HRTP and PWC_i was observed, it was not significant. Furthermore, a steady state exercise test just below velocity at the PWC_i and HRTP gave steady state conditions for LA in all cases. We contend that determination of the PWC_i is the preferred method because of an objective determination of the submaximal performance with respect to a lactate steady state.

The design of the incremental field test is comparable to the tests presented by Chin *et al*⁹ and Coen *et al*.¹¹ Their tests required technologically sophisticated equipment—that is, computer simulated light pulsations—that would preclude their routine application. Furthermore, these investigators used invasive procedures to determine AT, whereas we did not use such procedures in our incremental test. The workload at the PWC_i from our incremental test was lower than the workload found by Chin *et al*⁹ and Coen *et al*¹¹ by about 21 signals per minute. We attribute this finding to a lower skill level of the badminton players in our study. In addition, in our study there were no movement interruptions of the badminton players during the chosen incremental test procedures.

Numerous attempts have been made to determine the AT by non-invasive methods, such as by using HR.^{13 14 16 21} One possible method may be the use of a percentage of the age

Take home message

An incremental badminton specific field test was developed to determine sport specific performance. This test is easy to use without expensive equipment and without blood lactate determination and gives valid information about badminton specific aerobic and anaerobic performance.

predicted¹⁵ or measured^{26–28} HR_{max} . In addition, it has been reported that the percentage of HR at AT determined by different methods is usually 88–93% of HR_{max} .^{13 14 26–29} Therefore, a percentage of HR_{max} may be used for AT determination under field and laboratory conditions.

The “Conconi test” is often used to determine the AT because of its simplicity.^{16–22} Some discrepancies have been found with regard to the determination and validity of the HRT^{21 22}; however, it has also been shown that the AT determined using the HRT²¹ method is 88–93% of HR_{max} .^{18 19 21 24 26} Hofmann *et al*^{18 19} reported that the constant workload just below the predetermined HRT²¹ leads to lactate steady state values in both kayaking and cycle ergometer exercise.

On the basis of previous findings, we used an individual workload determined at 90% of HR_{max} defined as the PWC_i. We contend that this procedure provides two distinct advantages: (a) objectivity; (b) elimination of the problem of determining the HRT²¹ despite the absence of an invasive determination of the AT. It is important to note that differences between the HRT²¹ and the PWC_i were quite small when plotted against the mean values. Although PWC_i gave lower values for HR and velocity, the limits of agreement were very small, supporting the use of PWC_i rather than HRT²¹.

In summary, we determined the relation between the PWC_i and the AT, by performing a steady state test at an intensity just below PWC_i. Accordingly, we evaluated the HR and LA responses for the steady state conditions, as these variables are strongly related to training responses in endurance exercise.^{12 20} The mean steady state HR was found at 88.9% of the HR_{max} achieved during the incremental field test, which was below HR at the PWC_i and HRT²¹. Although we conducted the 20 minute steady state test after a warm up session, the HR and LA values did not increase during the last 15 minutes of the test. These values indicate that all subjects had attained steady state conditions for both HR and LA. It should be noted that a velocity slightly below PWC_i was used in order to adapt to fixed impulses from the pacer. Therefore, one may argue that the MLSS was not obtained. However, it is important to note that the PWC_i is a submaximal marker of aerobic performance, which correlates closely with the HRT²¹.

From these data, we conclude that the incremental badminton field test gives valid information about badminton specific aerobic performance and provides important information for prescribing aerobic exercise training. From a practical point of view, this test is easy for coaches and athletes to use as it allows investigation of several subjects at the same time without the use of expensive equipment.

Direct measurement of respiratory gas exchange variables under field conditions, as previously shown for tennis players,³⁰ may be useful in future research. Further studies under competition-like conditions may provide additional information about the impact of aerobic power in badminton.

Authors' affiliations

M Wonisch, W Klein, Department of Internal Medicine, University of Graz, Graz, Austria
 P Hofmann, Institute of Sports Sciences, University of Graz
 G Schwaberg, Department of Physiology, University of Graz

S P von Duvillard, Department of Kinesiology and Health Promotion, California State Polytechnic University, Pomona, California, USA

REFERENCES

- Steininger K, Wodick RE. Sports-specific fitness testing in squash. *Br J Sports Med* 1987;**21**:23–6.
- Docherty D. A comparison of heart rate responses in racquet games. *Br J Sports Med* 1982;**16**:96–100.
- Liddle SD, Murphy MH, Bleakley A. A comparison of the physiological demands of singles and doubles badminton: a heart rate and time-motion analysis. *J Sports Sci* 1997;**15**:17.
- Majumdar P, Khanna GL, Malik V, *et al*. Physiological analysis to quantify training load in badminton. *Br J Sports Med* 1997;**31**:342–5.
- Rittel HF, Waterloh E. Radiotelemetry of tennis, badminton-, and table tennis playing. (In German.) *Sportarzt und Sportmedizin* 1975;**15**:144–50, 177–81.
- Weber K. Analysis of physiological strain in different kinds of racket sports (tennis, table tennis, badminton and squash) with regard to preventive medicine and performance medicine (In German.). In: Andresen R, ed. Training in sportplay. *4th International Berliner Sportspiel-Symposium*. Ahrensburg bei Hamburg: Czwalina, 1982:111–33.
- Yoshida T, Watari H. Metabolic consequences of repeated exercise in long distance runners. *Eur J Appl Physiol* 1993;**67**:261–5.
- Tomlin DL, Wenger HA. The relationship between aerobic fitness and recovery from high intensity intermittent exercise. *Sports Med* 2001;**31**:1–11.
- Chin MK, Wong AS, So RCH, *et al*. Sport specific fitness testing of elite badminton players. *Br J Sports Med* 1995;**29**:153–7.
- Omosgard B. *Physical training for badminton*. Cheltenham: International Badminton Federation, 1996.
- Coen B, Urhausen A, Weiler B, *et al*. Badminton-specific performance-testing. (In German.) In: Dickhuth HH, Kuesswetter W, eds. *35th German Congress of Sports Medicine 25–27 Sept 1997*. Wehr/Baden: Novartis Pharma Verlag, 1997:95.
- Beneke R, von Duvillard SP. Determination of maximal lactate steady state response in selected sports events. *Med Sci Sports Exerc* 1996;**28**:241–6.
- Snyder AC, Woulfe T, Welsh R, *et al*. A simplified approach to estimating the maximal lactate steady state. *Int J Sports Med* 1994;**15**:27–31.
- Foster C, Crowe PC, Holm D, *et al*. The bloodless lactate profile. *Med Sci Sports Exerc* 1995;**27**:927–933.
- Hofmann P, Niederkofler W, Pokan R, *et al*. Individual physical working capacity. *Med Sci Sports Exerc* 1997;**29**:S204.
- Conconi F, Ferrrari M, Ziglio G, *et al*. Determination of the anaerobic threshold by a noninvasive field test in runners. *J Appl Physiol* 1982;**50**:383–92.
- Droghetti P, Borsetto C, Casoni I, *et al*. Noninvasive determination of the anaerobic threshold in canoeing, cross-country skiing, cycling, roller, and iceskating, rowing, and walking. *Eur J Appl Physiol* 1985;**53**:299–303.
- Hofmann P, Leitner H, Gaisl G, *et al*. A computer supported evaluation of the modified Conconi test on bicycle ergometer. In: Jarver J, ed. *A collection of European sports sciences translations*. Kidman Park: South Australian Sports Institute, 1994:51–2.
- Hofmann P, Peinhaupt G, Leitner H, *et al*. Evaluation of heart rate threshold by means of lactate steady and endurance tests in white water kayakers. In: Viitasalo JT, Kujala U, eds. *The way to win. Proceedings of the International Congress on Applied Research in Sports, Helsinki, Finland, August, 1994*. Helsinki: The Finnish Society for Research in Sport and Physical Education, 1995:217–20.
- Hofmann P, Bunc V, Leitner H, *et al*. Heart rate threshold related to lactate turn point and steady state exercise on cycle ergometer. *Eur J Appl Physiol* 1994;**69**:132–9.
- Conconi F, Grazi G, Casoni I, *et al*. The Conconi test: methodology after 12 years of application. *Int J Sports Med* 1996;**17**:509–19.
- Hofmann P, Pokan R, von Duvillard SP, *et al*. Heart rate performance curve during incremental cycle ergometer exercise in healthy young male subjects. *Med Sci Sports Exerc* 1997;**29**:762–8.
- Jones AM, Doust JH. Lack of reliability in Conconi's heart rate deflection point. *Int J Sports Med* 1996;**16**:541–4.
- Pokan R, Hofmann P, von Duvillard SP, *et al*. The heart rate turn point reliability and methodological aspects. *Med Sci Sports Exerc* 1999;**31**:903–7.
- Bland JM, Altman DG. Comparing methods of measurement: why plotting difference against standard method is misleading. *Lancet* 1995;**346**:1085–7.
- Fernández-Pastor VJ, Peréz F, Garcia AM, *et al*. Maintenance of the threshold/maximum heart rate quotient in swimmers. *J Physiol Biochem* 1997;**53**:327–34.
- Weltman A, Weltman J, Rutt R, *et al*. Percentages of maximal heart rate, heart rate reserve, and VO_2 peak for determining endurance training intensity in sedentary women. *Int J Sports Med* 1989;**10**:212–16.
- Weltman A, Snead D, Seip R, *et al*. Percentages of maximal heart rate, heart rate reserve and VO_2 max for determining endurance training intensity in male runners. *Int J Sports Med* 1990;**11**:218–22.
- Bunc V, Heller J, Novak J, *et al*. Ventilatory threshold in various groups of highly trained athletes. *Int J Sports Med* 1987;**8**:275–80.
- Smekal G, von Duvillard SP, Rihacek C, *et al*. A physiological profile of tennis match play. *Med Sci Sports Exerc* 2001;**33**:999–1005.