

## ORIGINAL ARTICLE

## Specific incremental test in elite squash players

O Girard, P Sciberras, M Habrard, P Hot, R Chevalier, G P Millet

*Br J Sports Med* 2005;39:921–926. doi: 10.1136/bjsm.2005.018101

See end of article for authors' affiliations

Correspondence to: O Girard, UPRES EA 3759, Faculty of Sport Sciences, University of Montpellier, Montpellier, France; olivier.girard@univ-montp1.fr

Accepted 17 May 2005

**Objectives:** To compare cardiorespiratory responses between incremental treadmill (non-specific) and field (sport specific) tests in elite squash players.

**Methods:** Seven elite players (ranked 1 to 25 in their national federation including the World number 1) randomly performed an incremental treadmill test (TT) and a squash specific graded test (ST) to exhaustion. The ST consisted of repeated displacements replicating the game of squash, at increasing speed on the court. In both tests, ventilatory variables and heart rate were determined at the ventilatory threshold, respiratory compensation point, and maximal loads (max).

**Results:** Heart rate and percentage maximal oxygen uptake ( $\dot{V}O_{2MAX}$ ) at the ventilatory threshold and respiratory compensation point were not different between the ST and TT, whereas  $\dot{V}O_{2MAX}$  was higher in the ST than in the TT (63.6 (3.0) v 54.9 (2.5) ml/kg/min;  $p < 0.001$ ). Time to exhaustion was not different between the ST and TT (1056 (180) v 962 (71) seconds) but correlated with the ranking of the players only in the ST ( $r = -0.96$ ,  $p < 0.001$ ).

**Conclusions:**  $\dot{V}O_{2MAX}$  values derived from laboratory testing were not relevant for accurately estimating fitness in elite squash players. So the ST may be used as an additional test for determination of training intensity. Improved training advice for prescribing aerobic exercise or perfecting stroke technique may result from these results.

In racket sports such as squash, success is largely dependent on technical, tactical, and motor coordination abilities.<sup>1</sup> However, the need for good aerobic fitness to maintain these abilities during a whole game (or tournament) can be a decisive factor.<sup>2,3</sup> Laboratory testing is commonly used to determine the metabolic profile of athletes, to evaluate physiological training induced changes and/or to determine appropriate training intensities. Maximal oxygen uptake ( $\dot{V}O_{2MAX}$ ) has traditionally been considered the key factor in aerobic performance. However, other physiological characteristics, such as the ability to maintain high percentages (80–90%) of maximum heart rate during long intermittent periods (>30–40 minutes), play a more relevant role in squash.<sup>4–5</sup> Two specific ventilatory changes that correspond to the ventilatory threshold (VT) and the respiratory compensation point (RCP) have been widely used in the sport science literature.<sup>6,7</sup> These reproducible ventilatory breakpoints are associated with simultaneous changes in blood lactate, electromyographic amplitude, and catecholamine concentration.<sup>8–11</sup>

To develop a test protocol to monitor the specific fitness of elite racket sports players, it is necessary to consider the nature of the game at the elite level and identify the most relevant physiological and technical variables that influence performance.<sup>12</sup> During treadmill testing, the continuous incremental exercise does not necessarily reflect the specific muscular involvement pattern of the intermittent high intensity exercise of ball or racket sports. The laboratory settings cannot simulate the physiological characteristics of squash, including many dynamic leg (repeated accelerations, decelerations, turns, and jumps) and arm (shoulder internal rotation, forearm pronation, wrist flexion) movements.<sup>4,13</sup> Only limited data are available on sport specific fitness tests in squash.<sup>2,3</sup> A specific test for squash players has been described by Steininger and Wodick,<sup>3</sup> in which players have to react to flashes of six bulbs by running towards and striking balloons mounted in the vicinity of the bulbs. A strong correlation ( $r = 0.90$ ) was reported between the ranking order of the subjects and the squash specific test

results, but not with any treadmill test results. These findings emphasise that the more specific the test, the more valid the results in determining fitness level.

Therefore the aims of this study were to: (a) develop a squash specific graded test including some elements of squash play in elite performers; (b) compare physiological responses recorded during this field test with those observed during an incremental treadmill test. We hypothesised that the physiological responses would differ because of the differences in movement patterns between the squash specific and treadmill tests and therefore that the treadmill test would be of little value for field training in elite squash players.

## METHODS

## Subjects

Seven well trained male squash players (mean (SD) age 24.9 (4.1) years; height 177.0 (5.9) cm; body mass 72.1 (6.1) kg) volunteered to participate in the study. Three were ranked within the top 50 in the PSA (Professional Squash Association) ranking, including the current number 1 and current World champion. The other subjects were ranked between 8 and 25 in their national squash federation. All subjects played in professional squash tournaments. The average time spent in training during the six months preceding the experiments was 22.8 (2.9) hours a week. All participants were fully informed of experimental procedures and possible discomfort associated with the study before giving their written consent to participate. The study was approved by the ethics committee of the University of Montpellier, France.

## Study protocol

All subjects carried out two incremental protocols to exhaustion in randomised order: a treadmill test (non-specific) and a squash graded test (sport specific). Each test

**Abbreviations:**  $\beta_{isocapnic}$ , isocapnic buffering; HHV, hypocapnic hyperventilation; HR, heart rate; RCP, respiratory compensation point;  $T_{ex}$ , time to exhaustion;  $\dot{V}O_{2MAX}$ , maximum oxygen uptake;  $V_t$ , tidal volume; VT, ventilatory threshold

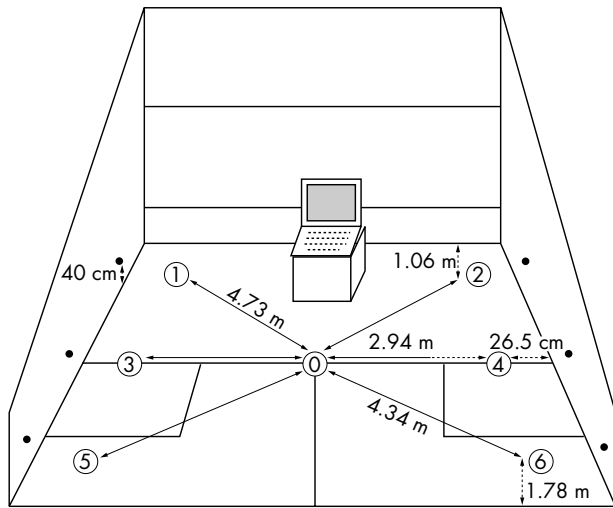

**Figure 1** Set up of the squash specific graded test (ST). The position of the central base (0) as well as forward (1 and 2), lateral (3 and 4), and backward (5 and 6) targets are indicated.

was conducted under standard environmental conditions (temperature ~25°C, relative humidity ~60%) at the same time of day. Four subjects performed two squash specific tests within one week to evaluate the reliability. This was done by calculating the relative difference and the coefficient of variation between test and retest.

**Experimental procedures**  
**Treadmill testing**

The treadmill incremental test to exhaustion (TT) was performed on a motorised treadmill (S2500; Medical Development, Andrezieux, France). It consisted of an initial two minute workload of 10 km/h followed by increases of 1 km/h every two minutes (0% incline). The test ended with voluntary exhaustion of the subjects.

**Field testing**

A squash specific graded test (ST) was developed in which subjects repeated displacements that simulated the game of squash, at increasing speed on a squash court. Each intensity level (a stage) consisted of two bouts of nine shuttle runs (a sequence), performed from a central base to one of six targets located around the court, alternated with 10 seconds of active recovery (fig 1). Each stage was composed of nine displacements, including two forward, three lateral, and four backward courses, performed randomly. When the subject arrived at the target, he was instructed to mime a powerful stroke in the direction of the front wall with his racket under a 40 cm height marker fixed on the side wall, before moving back to the “T” after each drive. Subjects were asked to use the same running technique as in competition. A 10 second rest period was taken between each stage, and a 30 second rest between the end of stage 3 (end of warm up period) and the beginning of stage 4. The duration of the first sequence was 38 seconds; this was progressively decreased by 1.8 seconds (stages 1 to 2 and 2 to 3) and 0.9 second (stages 4 to 17). Movement velocities and directions were controlled by visual and sound feedback from a PC. Briefly, specialised software was used to simultaneously activate a tune and project a picture of a player indicating with his racquet the target to reach. These velocities and sequences of movement were calculated from data collected during official competitions (unpublished data). The test ended when the player failed to reach the target in time (a 1 m delay was permitted) or was no longer able to fulfil the criteria of the test—that is, perform strokes with acceptable technique. To avoid interruption of data collection, players were not allowed to drink during the ST.

**Physiological measurements**

During the TT (CPX/D; MedGraphics, Saint Paul, Minnesota, USA) and ST (K4<sup>b2</sup>; Cosmed, Rome, Italy), the following gas exchange data were obtained using breath by breath gas analysers calibrated before each test using the manufacturers’ recommendations:  $\dot{V}O_2$ , carbon dioxide production ( $\dot{V}CO_2$ ), respiratory exchange ratio ( $\dot{V}CO_2/\dot{V}O_2$ ), minute ventilation ( $\dot{V}E$ ), breathing frequency, and tidal volume. Five

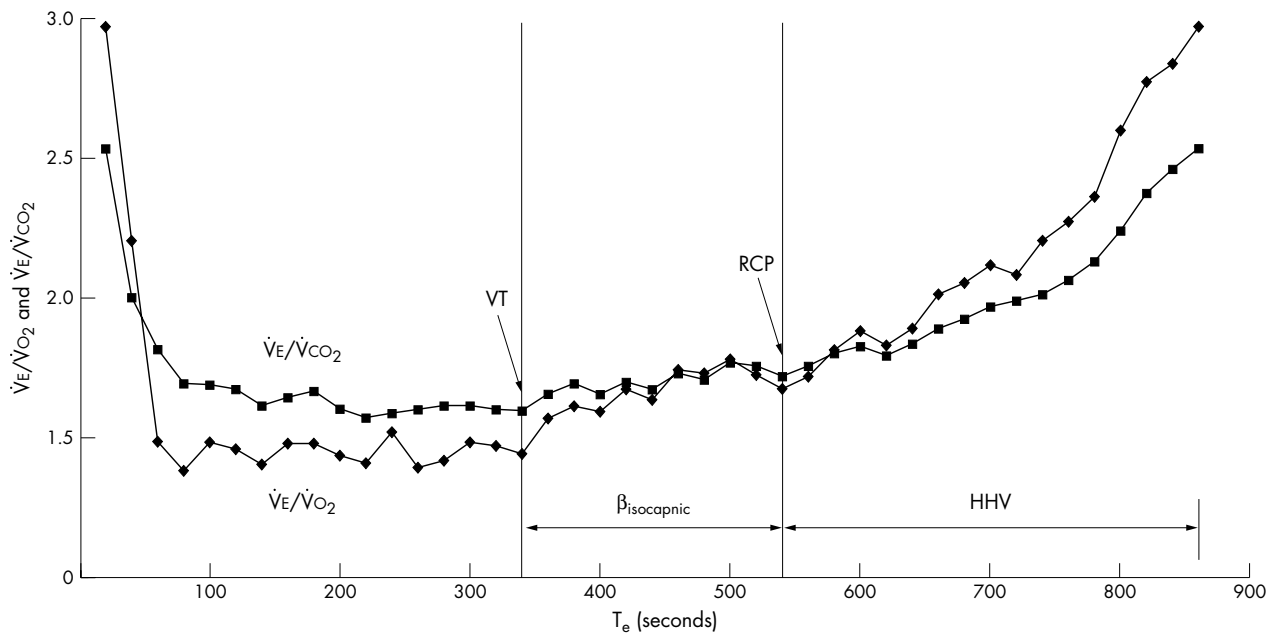

**Figure 2** Determination of isocapnic buffering ( $\beta_{isocapnic}$ ) and hypocapnic hyperventilation (HHV) phases in one subject. Mean values of both ventilatory equivalents for oxygen and carbon dioxide ( $\dot{V}E/\dot{V}O_2$  and  $\dot{V}E/\dot{V}CO_2$ ) are plotted for each 30 second interval. VT, Ventilatory threshold; RCP, respiratory compensation point;  $T_e$ , time to exhaustion.

**Table 1** Physiological variables in elite squash players corresponding to the ventilatory threshold for the treadmill incremental test to exhaustion (TT) and squash specific graded test (ST) (n = 7)

Variable	TT	ST	p Value
$\dot{V}O_2$ (ml/min/kg)	45.8 (6.1)	53.6 (2.5)	<0.01
$\dot{V}CO_2$ (ml/min/kg)	36.1 (11.0)	50.1 (3.3)	<0.01
RER	0.93 (0.06)	0.94 (0.06)	NS
$\dot{V}E$ (litres/min)	80.0 (8.8)	86.8 (11.3)	NS
HR (beats/min)	167.8 (17.5)	170.5 (13.8)	NS
Bf (breaths/min)	31.3 (3.5)	39.3 (5.1)	<0.05
Vt (litres)	2.49 (0.57)	2.25 (0.41)	NS
% $\dot{V}O_{2MAX}$	83.2 (8.3)	84.5 (5.7)	NS
%HR <sub>max</sub>	86.0 (6.3)	87.8 (4.8)	NS

Values are mean (SD).

$\dot{V}O_2$ , Oxygen uptake;  $\dot{V}CO_2$ , carbon dioxide production; RER, respiratory exchange ratio;  $\dot{V}E$ , minute ventilation; HR, heart rate; Bf, breathing frequency; Vt, tidal volume;  $\dot{V}O_{2MAX}$ , maximal oxygen uptake; HR<sub>max</sub>, maximal heart rate.

second heart rate (HR) values were recorded with a HR monitor with the athletes wearing a chest belt (S810; Polar, Kempele, Finland). The discrepancies between the two analysers has been shown to be non-significant,<sup>14</sup> and in our laboratory the differences in  $\dot{V}O_2$  values between the analysers were less than 2%.<sup>15</sup>

In both tests (TT and ST), the gas samples were averaged every 30 seconds, and the highest values for  $\dot{V}O_2$  and HR over 30 seconds were regarded as maximum oxygen uptake ( $\dot{V}O_{2MAX}$ ) and heart rate (HR<sub>max</sub>). Three criteria were used to determine maximal effort:<sup>16</sup>

- (1) A plateau or levelling off of  $\dot{V}O_2$ , defined as an increase of less than 1.5 ml/kg/min despite progressive increases in exercise intensity
- (2) A final respiratory exchange ratio of 1.1 or above
- (3) A final HR above 95% of the age related maximum

Time to exhaustion ( $T_e$ , seconds) was recorded in each test.

#### Determination of VT and RCP

VT was determined using the criteria of an increase in  $\dot{V}E/\dot{V}O_2$  with no increase in  $\dot{V}E/\dot{V}CO_2$  and the departure from linearity of  $\dot{V}E$ , whereas RCP corresponded to an increase in both  $\dot{V}E/\dot{V}O_2$  and  $\dot{V}E/\dot{V}CO_2$ .<sup>17</sup> All measurements of VT and RCP were made by visual inspection of graphs of time plotted against each relevant respiratory variable measured during testing. The visual inspections were made by two experienced exercise physiologists; the results were compared and then averaged. The difference in the individual determinations of VT and RCP was <3%. Each physiological variable

corresponding to VT, RCP, and maximal load was expressed in absolute terms and relative to  $\dot{V}O_{2MAX}$  and HR<sub>max</sub>.

#### Determination of isocapnic buffering ( $\beta_{isocapnic}$ ) and hypocapnic hyperventilation (HHV) phases

The  $\beta_{isocapnic}$  and HHV ranges were defined as  $\dot{V}O_2$  and HR from VT to RCP, and  $\dot{V}O_2$  and HR from RCP to the end of exercise respectively.<sup>18</sup> Figure 2 shows an example of determination of  $\beta_{isocapnic}$  and HHV range in one subject.

#### Statistical analysis

Mean (SD) was calculated for all variables. Data obtained at VT, RCP, and maximal load as well as for  $\beta_{isocapnic}$  and HHV were compared between the ST and TT, using paired sample *t* tests. Pearson correlation coefficients were used to examine the relations between study variables.  $T_e$  during the ST and TT was correlated with the ranking of the players using Spearman rank order correlation. For all statistical analyses,  $p < 0.05$  was accepted as the level of significance.

#### RESULTS

No difference was found in  $T_e$  (1085 (267) *v* 1099 (195) seconds; coefficient of variation = 0.9%) and HR<sub>max</sub> (192.2 (4.5) *v* 187.5 (6.1) beats/min; coefficient of variation = 1.8%) between two STs performed within one week (n = 4). In both tests, the criterion of  $\dot{V}O_2$  plateau was satisfied by all subjects. However, only 86% of subjects satisfied the respiratory exchange ratio criteria for maximal effort, and fewer (57%) attained the HR criteria in the two tests.  $T_e$  did not differ ( $p = 0.45$ ) between the ST and TT (1056 (180) *v* 962 (71) seconds). At VT and RCP,  $\dot{V}O_2$ ,  $\dot{V}CO_2$  and breathing

**Table 2** Physiological variables in elite squash players corresponding to the respiratory compensation point for the treadmill incremental test to exhaustion (TT) and squash specific graded test (ST) (n = 7)

Variable	TT	ST	p Value
$\dot{V}O_2$ (ml/min/kg)	50.5 (4.3)	57.6 (3.9)	<0.01
$\dot{V}CO_2$ (ml/min/kg)	42.5 (12.8)	57.8 (4.8)	<0.05
RER	0.99 (0.07)	1.00 (0.03)	NS
$\dot{V}E$ (litres/min)	97.5 (9.1)	106.6 (13.2)	NS
HR (beats/min)	179.8 (10.3)	183.8 (10.6)	NS
Bf (breaths/min)	35.9 (5.7)	44.7 (6.7)	<0.05
Vt (litres)	2.64 (0.51)	2.43 (0.41)	NS
% $\dot{V}O_{2MAX}$	92.0 (5.6)	90.5 (3.5)	NS
%HR <sub>max</sub>	92.3 (2.6)	95.2 (2.9)	NS

Values are mean (SD).

$\dot{V}O_2$ , Oxygen uptake;  $\dot{V}CO_2$ , carbon dioxide production; RER, respiratory exchange ratio;  $\dot{V}E$ , minute ventilation; HR, heart rate; Bf, breathing frequency; Vt, tidal volume;  $\dot{V}O_{2MAX}$ , maximal oxygen uptake; HR<sub>max</sub>, maximal heart rate.

**Table 3** Physiological variables in elite squash players corresponding to the maximum work load for treadmill incremental test to exhaustion (TT) and squash specific graded test (ST) (n = 7)

Variable	TT	ST	p Value
$\dot{V}O_2$ (ml/min/kg)	54.9 (2.5)	63.6 (3.0)	<0.001
$\dot{V}CO_2$ (ml/min/kg)	51.4 (15.2)	68.5 (3.5)	<0.05
RER	1.10 (0.05)	1.10 (0.06)	NS
$\dot{V}E$ (litres/min)	133.9 (12.8)	149.0 (15.2)	NS
HR (beats/min)	194.8 (8.6)	193.0 (7.9)	NS
Bf (breaths/min)	50.2 (8.7)	59.1 (6.6)	<0.05
Vt (litres)	2.70 (0.44)	2.72 (0.30)	NS

Values are mean (SD).  
 $\dot{V}O_2$ , Oxygen uptake;  $\dot{V}CO_2$ , carbon dioxide production; RER, respiratory exchange ratio;  $\dot{V}E$ , minute ventilation; HR, heart rate; Bf, breathing frequency; Vt, tidal volume.

frequency were significantly higher in the ST than the TT, whereas no difference was observed in the other variables (tables 1 and 2). It is of interest to note that HR and  $\% \dot{V}O_{2MAX}$  at VT and RCP were not different between the ST and TT.

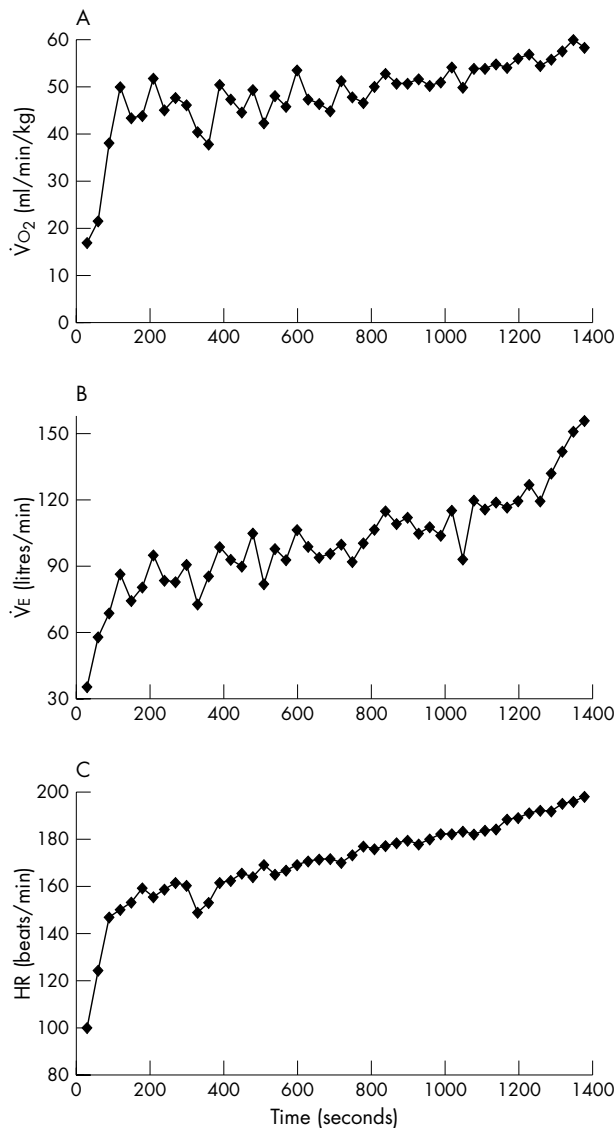

**Figure 3** Oxygen uptake ( $\dot{V}O_2$ , A), minute ventilation ( $\dot{V}E$ , B), and heart rate (HR, C), during the squash specific graded test in one subject. Mean values of both physiological variables are plotted for each 30 second interval.

Again,  $\dot{V}O_2$ ,  $\dot{V}CO_2$  and breathing frequency measured at maximal loads were significantly higher in the ST than in the TT (table 3). Figure 3 shows  $\dot{V}O_2$ ,  $\dot{V}E$ , and HR during the ST in one subject. The competition ranking of the players correlated with  $T_e$  in the ST ( $r = -0.96$ ,  $p < 0.001$ ) (fig 4), but not in the TT. Mean values of  $\dot{V}O_2$  (4.7 (3.4) and 3.2 (4.9) v 4.4 (2.8) and 6.0 (2.2) ml/min/kg) and HR (12.0 (8.2) and 13.7 (5.4) v 15.0 (4.5) and 9.2 (5) beats/min) for  $\beta_{isocapnic}$  and HHV phases did not differ between the TT and ST respectively.

**DISCUSSION**

The incremental field test (ST) allowed high maximal  $\dot{V}O_2$  values to be reached in elite squash players. It appears to be an efficient method for assessing squash performance as it is very specific—that is, it closely replicates movements characteristic of squash—and shows strong correlation with player ranking. However, the TT results (HR and  $\% \dot{V}O_{2MAX}$ ) were similar at submaximal intensities (VT and RCP). So the TT appears to be valid for prescribing HR training intensity zones for “on court” squash training.

In ball and racquet sports such as squash, exercise testing on the treadmill—that is, running—is not specific for the muscles involved and is therefore not adequate for evaluating the specific demands of the sport.<sup>2,3</sup> Steininger and Wodick<sup>3</sup> were the first to report a positive correlation ( $r = 0.90$ ;  $p < 0.05$ ) between performance during a specific squash test and ranking of the players. Therefore we designed a squash specific graded test that included technical characteristics (performed on a squash court; similar displacement technique to competition; uncertain direction of motion; simulation of ball hitting) and compared the cardiorespiratory responses with those obtained in an incremental treadmill test.

**Maximal loads**

In both tests, the criteria of  $\dot{V}O_2$  plateau, respiratory exchange ratio, and  $HR_{max}$  were satisfied by all subjects. Therefore the

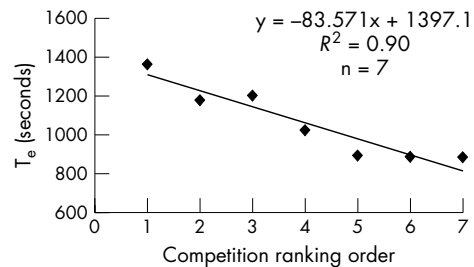

**Figure 4** Relation between the ranking order of each player (1 to 7 in the 2004 international ranking) and the time to exhaustion ( $T_e$ , seconds) during the squash specific graded test.



### What is already known on this topic

- Incremental treadmill tests are commonly used to determine exercise performance of squash players and the appropriate training intensity to elicit the optimal aerobic and anaerobic capacity
- However, laboratory settings on any ergometer cannot simulate the intermittent pattern of the movements of squash; thus “on court” endurance fitness testing is needed

low frequency of the “plateau phenomenon” in highly skilled athletes could not explain the differences in  $\dot{V}O_{2\text{MAX}}$ .<sup>16</sup> It is important to note the  $\dot{V}O_{2\text{MAX}}$  values determined from the ST. They confirm that high aerobic power is needed for top level competition in squash. This is in agreement with previous findings.<sup>2, 19</sup> The sport specific nature of the ST—that is, motivation, displacement in all directions including changeovers, upper arm involvement with racquet holding and simulation of ball hitting actions—may explain the differences observed between the tests. A possible explanation could be the respective muscle masses involved in the specific (ST) and non-specific (TT) tests. As suggested by Steininger and Wodick,<sup>3</sup> one can assume that greater muscle mass is used in the ST because the subjects have to use their upper limbs for racquet holding and simulation of ball hitting. Therefore muscles of the torso and arms were probably recruited at a higher rate than during the TT and may have increased  $\dot{V}O_2$  in the ST. The higher values reached in the ST may also be the result of greater motivation when players have to hit a ball.

### VT and RCP

To evaluate the physiological differences at submaximal intensities between the two tests, VT and RCP were used as reference variables. The validity and reliability of the method used to identify VT and RCP (visual inspection of the breakpoint in the ventilatory equivalents for  $\dot{V}O_2$  and  $\dot{V}CO_2$ ) have been confirmed by comparison with computerised methods.<sup>20</sup> In addition, the differences between the results of the two researchers were small (~3%). One may therefore argue that VT and RCP have been identified in an appropriate way. Another way of confirming the RCP breakpoint would be to determine the maximal lactate steady state, as shown in badminton by Wonisch *et al.*<sup>21</sup> However, it has been reported that blood lactate alone is not adequate for appropriate interpretation of the energy demands in intermittent sports.<sup>22</sup>

In this study, the values of VT and RCP were higher than those previously reported in physically active subjects (42–77% and 74–88% of the  $\dot{V}O_{2\text{MAX}}$  for VT and RCP respectively).<sup>20, 21</sup> These discrepancies are mainly explained by the high performance level of the present subjects. Billat<sup>23</sup> postulated that highly trained subjects are capable of maintaining the oxidative pathway without lactate accumulation to more than 90% of their  $\dot{V}O_{2\text{MAX}}$ . The high values of VT and RCP and the corresponding reduction in the HHV range confirm that one of the most significant characteristics of professional squash players is their capacity to perform at high workloads (74% of  $\dot{V}O_{2\text{MAX}}$ ) during competition.<sup>3</sup> This can be interpreted as a great ability to work at high intensity before acid accumulation occurs in the blood. One could argue that intense training sessions involving anaerobic metabolism performed by elite squash players<sup>24</sup> improve the buffering capacity leading to a shift in RCP.

We hypothesised that the physiological responses would differ between the squash and treadmill tests because of the

### What this study adds

- A specific fitness test for squash players reflecting the physiological and technical demands of the sport is presented
- The benefits of this test are considerable, as it can be used to prescribe physiological training intensity zones for “on court” squash training and is an efficient protocol for assessing performance level

differences in movement patterns between running (continuous) and playing squash (start and stop). We also hypothesised that these differences would be very large in these elite subjects, for whom specific training represents a major part of their programme. However, the values of variables related to VT and RCP as well as  $\beta_{\text{isocapnic}}$  and HHV phases were similar between the TT and ST. The fact that both VT and RCP were expressed at the same relative intensity ( $\% \dot{V}O_{2\text{MAX}}$ ) and corresponded to the same HR is of great interest for coaches. Thus the intensity zones (<VT; VT <> RCP; >RCP) defined by HR values measured on the treadmill are probably valid for “on court” squash training.

### Training applications

Training regimens have to be designed on the basis of physiological data recorded during competition. A large part of an effective training regimen for the competitive squash player will therefore take place on the court involving activities of real match play.<sup>5</sup> It has been estimated that a good male player makes up to 22 strokes a minute,<sup>24</sup> which compares with the final stages of the ST. In this context, one may argue that the ST places a specific demand on the player and would therefore be an appropriate test to be included in a training routine. The intermittent characteristic of the ST also appears to be a strong point. In 20 professional soccer players, individual results in intermittent and continuous testing protocols were compared with actual soccer performance.<sup>25</sup> The authors reported that only the intermittent test results correlated ( $r = 0.83$ ) with match performance—that is, distance covered. In squash, Sharp<sup>24</sup> described the practice of “shadow training” in which a player has to follow an imaginary opponent around the court. Several work periods (30–60 seconds) and work to rest ratios (0.5–2) were used that produced blood lactate concentrations similar to competition values. As  $\dot{V}O_2$  and HR are known to be less variable than blood lactate for monitoring fitness changes,<sup>26</sup> the present study shows that HR values at VT, RCP, and  $\dot{V}O_{2\text{MAX}}$ , which did not differ in the treadmill and on court graded tests, can be used to define HR training intensity zones.

### CONCLUSIONS

In summary, this incremental field test allowed high maximal values to be reached in elite squash players. Time to exhaustion correlated strongly with the ranking of the players. Therefore this test seems to be an efficient and very specific (close to the characteristics of squash competition) protocol for assessing performance level. However, incremental treadmill test results (HR and  $\% \dot{V}O_{2\text{MAX}}$ ) were similar at submaximal intensities. Therefore the latter seem to be valid for prescribing HR intensity zones for “on court” squash training. To conclude, field and laboratory tests appear to be complementary and of different use in monitoring fitness changes in elite squash players.

## ACKNOWLEDGEMENTS

We thank the athletes for their participation in this study and the Squash Club de Montpellier for the facilities.

### Authors' affiliations

**O Girard, P Sciberras, M Habrard**, UPRES EA 2991, Faculty of Sport Sciences, University of Montpellier, Montpellier, France

**P Hot, R Chevalier**, CREOPP, Faculty of Sport Sciences

**G P Millet**, ASPIRE, Academy for Sports Excellence, Doha, Qatar

Competing interests: none declared

## REFERENCES

- 1 **Lees A**. Science and the major racket sports: a review. *J Sports Sci* 2003;**21**:707–32.
- 2 **Chin MK**, Steininger K, So RC, et al. Physiological profiles and sport specific fitness of Asian elite squash players. *Br J Sports Med* 1995;**29**:158–64.
- 3 **Steininger K**, Wodick RE. Sports-specific fitness testing in squash. *Br J Sports Med* 1987;**21**:23–6.
- 4 **Montpetit RR**. Applied physiology of squash. *Sports Med* 1990;**10**:31–41.
- 5 **Todd MK**, Mahoney CA, Wallace WFM. The efficacy of training routines as a preparation for competitive squash. In: Lees A, Hughes M, Reilly T, eds. *Science and racket sports II*. London: E & FN Spon, 1998:91–6.
- 6 **Wasserman K**, Hansen JE, Sue DY, et al. *Principles of exercise testing and interpretation*. Philadelphia: Lea & Febiger, 1987.
- 7 **Whipp BJ**, Davis JA, Wasserman K. Ventilatory control of the 'isocapnic buffering' region in rapidly-incremental exercise. *Respir Physiol* 1989;**76**:357–67.
- 8 **Foster C**, Green MA, Snyder AC, et al. Physiological responses during simulated competition. *Med Sci Sports Exerc* 1993;**25**:877–82.
- 9 **Chwalbinska-Moneta J**, Kaciuba-Uscilko H, Krzyzofiak H, et al. Relationship between EMG blood lactate, and plasma catecholamine thresholds during graded exercise in men. *J Physiol Pharmacol* 1998;**49**:433–41.
- 10 **Gaesser GA**, Poole DC. Lactate and ventilatory thresholds: disparity in time course of adaptations to training. *J Appl Physiol* 1986;**61**:999–1004.
- 11 **Poole DC**, Gaesser GA. Response of ventilatory and lactate thresholds to continuous and interval training. *J Appl Physiol* 1985;**58**:1115–21.
- 12 **Hughes MD**, Fullerton FM. Development of an on-court aerobic test for elite badminton players. In: Reilly T, Hughes M, Lees A, eds. *Science and racket sports*. London: E & FN Spon, 1995:51–4.
- 13 **Reilly T**. The racquet sports. In: Reilly T, Snell P, Williams C, eds. *Physiology of sports*. London: E and FN Spon, 1990:337–69.
- 14 **McLaughlin JE**, King GA, Howley ET, et al. Validation of the Cosmed K4b<sup>2</sup> portable metabolic system. *Int J Sports Med* 2001;**22**:280–4.
- 15 **Roels B**, Millet GP, Marcoux CJ, et al. Effects of hypoxic interval training on cycling performance. *Med Sci Sports Exerc* 2005;**37**:138–46.
- 16 **Doherty M**, Nobbs L, Noakes TD. Low frequency of the "plateau phenomenon" during maximal exercise in elite British athletes. *Eur J Appl Physiol* 2003;**89**:619–23.
- 17 **Davis JA**. Anaerobic threshold: review of the concept and directions for future research. *Med Sci Sports Exerc* 1985;**17**:6–21.
- 18 **Oshima Y**, Tanaka S, Miyamoto T. Effects of endurance training above the anaerobic threshold on isocapnic buffering phase during incremental exercise in middle-distance runners. *Japanese Journal of Physical Fitness and Sports Medicine* 1998;**47**:43–52.
- 19 **Todd MK**, Mahoney CA. Determination of pre-season physiological characteristics of elite male squash players. In: Reilly T, Hughes M, Lees A, eds. *Science and racket sports*. London: E & FN Spon, 1995:81–8.
- 20 **Santos EL**, Giannella-Neto A. Comparison of computerized methods for detecting the ventilatory thresholds. *Eur J Appl Physiol* 2004;**93**:315–24.
- 21 **Wonisch M**, Hofmann P, Schwaberg G, et al. Validation of a field test for the non-invasive determination of badminton specific aerobic performance. *Br J Sports Med* 2003;**37**:115–18.
- 22 **Smekal G**, Von Duvillard SP, Pokan R, et al. Changes in blood lactate and respiratory gas exchange measures in sports with discontinuous load profiles. *Eur J Appl Physiol* 2003;**89**:489–95.
- 23 **Billat VL**. Use of blood lactate measurements for prediction of exercise performance and for control of training. *Sports Med* 1996;**22**:157–75.
- 24 **Sharp NCC**. Physiological demands and fitness for squash. In: Lees A, Hughes M, Reilly T, eds. *Science and racket sports II*. London: E & FN Spon, 1998:3–13.
- 25 **Bangsbo J**, Lindquist F. Comparison of various exercise tests with endurance performance during soccer in professional players. *Int J Sports Med* 1992;**13**:125–32.
- 26 **Christmass MA**, Richmond SE, Cable NT, et al. Exercise intensity and metabolic response in singles tennis. *J Sports Sci* 1998;**16**:739–47.