

Neurological aspects of biopterin metabolism

I SMITH, R J LEEMING, N P C CAVANAGH, AND K HYLAND

Hospital for Sick Children and Institute of Child Health, London, and The General Hospital, Birmingham

SUMMARY Plasma total biopterin concentration was measured by bioassay in 59 infants with hyperphenylalaninaemia and in 50 children with developmental regression and or movement disorder with normal plasma phenylalanine concentrations. In infants with raised phenylalanine concentrations plasma biopterin concentrations were significantly raised in proportion to the phenylalanine values. Five patients had plasma biopterin concentrations at the extremes of the range, and of these two had defective biopterin metabolism. One with low plasma biopterin concentration apparently had a partial defect of biopterin synthesis but died before investigations were complete. One with high plasma biopterin concentration, even when phenylalanine concentrations had fallen to the normal range, had dihydropteridine reductase deficiency. In this patient concentrations of homovanillic acid and 5-hydroxyindolacetic acid in the cerebrospinal fluid (CSF) were severely reduced.

In children without hyperphenylalaninaemia plasma biopterin concentrations were normal. Twenty two patients were subjected to lumbar puncture, of whom six with developmental regression without movement disorder had normal CSF biopterin concentrations, and 11 with movement disorder other than torsion dystonia had significantly lower CSF biopterin concentrations. Five patients with torsion dystonia had normal biopterin concentrations.

Tetrahydrobiopterin is the essential cofactor for three hydroxylation reactions, the conversion of phenylalanine to tyrosine, tyrosine to L-dopa, and tryptophan to 5-hydroxytryptophan.¹ These last two reactions are the rate limiting steps of catecholamine and serotonin synthesis. Deficiency of tetrahydrobiopterin, due either to defective biopterin synthesis from guanosine triphosphate or dihydropteridine reductase deficiency (Fig. 1), is the cause of hyperphenylalaninaemia in 1-3% of infants detected on routine neonatal screening.²⁻⁵ Children with deficiency of tetrahydrobiopterin may develop progressive neurological disease, in which movement disorder is a prominent feature and which is unresponsive to a low phenylalanine diet and due in large part to deficiency of neurotransmitter amines. We wished to assess whether measurement of plasma total biopterin concentrations would help in distinguishing patients with hyperphenylalaninaemia due to defective biopterin metabolism from those with phenylalanine hydroxylase deficiency.

Symptomless patients with normal plasma phenylalanine concentrations, yet defective biopterin synthesis, have been described,⁶ and others may

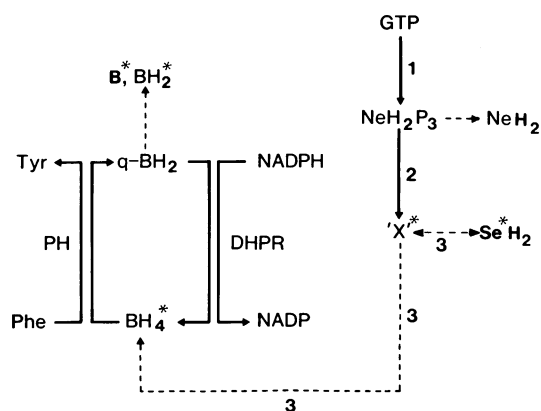

Fig. 1 Synthesis and recycling of tetrahydrobiopterin (BH_4).

GTP=guanosine triphosphate, NeH_2P_3 =dihydroneopterin triphosphate, NeH_2 =dihydroneopterin, X^* =tetrahydroketopterin, SeH_2 =sepiapterin, $q-BH_2$ =quinonoid-dihydrobiopterin, $BH_2=7, 8$ dihydrobiopterin, B=biopterin, * = active in *Crithidia fasciculata* bioassay. Phe=phenylalanine, Tyr=tyrosine. Enzymes: PH=phenylalanine hydroxylase, DHPR=dihydropteridine reductase, 1=GTP cyclohydrolase, 2=tetrahydroketopterin synthesising enzyme, 3=sepiapterin reductase.

have symptoms, and/or phenylalanine accumulation, only when exposed to an excessive phenylalanine intake.⁷ It is not known how many children with neurological disease may be suffering from occult disorders of biopterin metabolism, and part of the present study was to assess the prevalence of such disorders among children with severe neurological disease, especially that accompanied by movement disorder. Adults with movement disorder may have reduced 'hydroxylase cofactor activity' in cerebrospinal fluid (CSF),^{8,9} and there are reports of impaired biopterin synthesis in the brains of patients with senile dementia.¹⁰

Patients

Infants with phenylketonuria. Plasma was obtained from 53 consecutive infants detected on routine neonatal screening before introduction of the low phenylalanine diet. Seventeen were retested after a few weeks on treatment. Plasma was also obtained from six infants who had already started the diet when first seen. Five infants underwent further investigation (see below), including lumbar puncture in one patient, because initial biopterin concentrations were 'high' or 'low' (2SDs) compared with the rest of the group.

Patients with neurological disorder. These were 50 children aged 1 month to 16 years undergoing neurological investigation because of developmental regression or extrapyramidal disturbance. They were investigated with the permission of their parents and with the approval of the hospital ethical committee. All had plasma phenylalanine concentrations below 200 $\mu\text{mol/l}$ (3.3 mg/100 ml), and the pathogenesis of their illness remained obscure despite extensive investigation. Five patients had torsion dystonia, four had dominantly inherited tics, 19 had developmental regression, accompanied by epilepsy in nine, and in a further 22 patients severe extrapyramidal disturbance (choreoathetosis, tremor, dystonic posturing) was a prominent feature of their illness, accompanied by mental retardation in 13 and epilepsy in eight. Plasma was also obtained from the four affected parents with dominantly inherited tics.

Methods

Measurement of total biopterin activity. Heparinised blood 1–2 ml was obtained by venepuncture, and plasma was separated by centrifugation. Between 0.5 and 1 ml of CSF was obtained by lumbar puncture using a standard technique. Specimens were frozen as soon as possible and stored at -20°C .

For analysis, samples were thawed, diluted with 0.2 molar, pH 5.0 phosphate buffer 1:20, autoclaved, and assayed as described previously using *Crithidia fasciculata*.^{6,11} The growth response was read against a pooled plasma blank using standards of tetrahydrobiopterin. In two patients with inborn errors of biopterin metabolism the crithidia results were confirmed by urine pterin analysis¹² (Dr A Niederwieser, Zurich; Professor J A Blair, Birmingham) using high performance liquid chromatography. Urine contains roughly 1000 times the concentrations of total biopterin compared with those in plasma.¹¹

Oral load of tetrahydrobiopterin. The protocol used here was that of Niederwieser *et al.*¹³ The test is carried out when plasma phenylalanine concentrations are raised. After an overnight fast 7.5 mg/kg of tetrahydrobiopterin combined with vitamin C (supplied by B Schircks, Zurich) was given on a spoon. Plasma phenylalanine and tyrosine concentrations were measured at baseline and at one, two, four, six, eight, and 24 hours, and urine, or plasma, biopterin concentrations were measured to show that the tetrahydrobiopterin had been absorbed.

Oral load of L-phenylalanine. After an overnight fast 100 mg/kg of L-phenylalanine was given dissolved in fruit juice and plasma phenylalanine; tyrosine and biopterin concentrations were measured at baseline one, two, three, four, and six hours.⁶

Assay of dihydropteridine reductase activity. This is the diagnostic test for inherited deficiency of dihydropteridine reductase activity, and the assay is now carried out on dried blood spots^{14,15} in all new patients presenting with phenylketonuria at our clinic.

These procedures were not available in our laboratory until the end of the present study and liver biopsy was carried out in one patient for measurement of dihydropteridine reductase and phenylalanine hydroxylase activities by Dr F Rey, Paris.⁵

Measurement of homovanillic acid and 5-hydroxyindolacetic acid. The first 0.5 ml of CSF was placed on cardice at the bedside and stored at -20°C . Measurements were made using high performance liquid chromatography with electrochemical detection. Concentrations of homovanillic and 5-hydroxyindolacetic acids in CSF provide an approximate index of dopamine and serotonin turnover in the central nervous system¹⁶ and have been used here to assess the central effects of disturbed biopterin metabolism. Homovanillic and

5-hydroxyindolacetic acids in lumbar CSF are higher in early childhood than in later life,¹⁶ so results need to be compared with controls of similar age. Only limited control data were available from our own studies, but this is consistent with the data of Siefert *et al.*¹⁶ Initially, these measurements were not available in our own laboratory, and the assays were done by Dr M Tricklebank, London.

Results

Infants with phenylketonuria. In comparison with healthy children⁶ and infants with neurological disorder, plasma biopterin concentrations were markedly raised (Fig. 2). Generally, the least rise was present in the infants with phenylalanine concentrations closest to the normal range, but even in the group with phenylalanine concentrations below 400 µmol/l (6.6 mg/100 ml) the mean plasma biopterin concentration (3.16 ng/ml) was significantly raised in comparison with the mean (2.2 ng/ml) for infants under 2 months of age with neurological disorder ($t=2.23, 0.02 > p < 0.05$). In

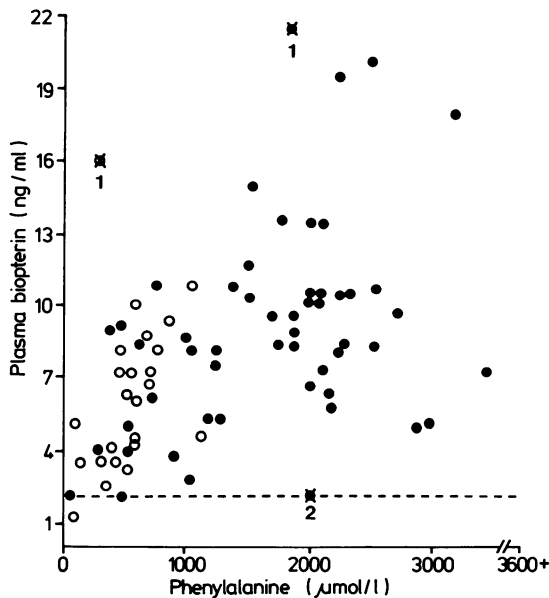

Fig. 2 Plasma biopterins measured by crithidia assay versus plasma phenylalanine concentrations in 59 infants with phenylketonuria, pretreatment (●) and on a low phenylalanine diet (○). - - - - = Mean value of biopterin in six control infants.

Case 1 had deficiency of dihydropteridine reductase activity, and case 2 has defective biopterin synthesis.

Conversion: SI to traditional units—Phenylalanine: 1 mmol/l ≈ 16.5 mg/100 ml.

patients with plasma phenylalanine concentrations below 2000 µmol/l (33 mg/100 ml) there was a broadly linear relation and a significant positive correlation between biopterin and phenylalanine concentrations ($r=0.68, t=2.640, 0.01 > p < 0.02$). At higher phenylalanine concentrations the scatter of results widened, and the linear relation was lost. The correlation between plasma biopterin and phenylalanine concentrations was closer for patients on a low phenylalanine diet ($r=0.89, t=2.941, 0.001 > p < 0.01$).

Five patients had plasma biopterin concentrations at or outside 2SDs from the means for other patients with similar phenylalanine concentrations (Table 1). Further investigation of biopterin metabolism in three of the five gave normal results as follows. In one patient with an initial biopterin concentration of 18 ng/ml plasma biopterin concentration fell to the normal range (2.1 ng/ml) when a plasma phenylalanine was 60 µmol/l (1 mg/100 ml), and no further investigation was undertaken. In another patient with an initial biopterin concentration of 20.5 ng/ml the value fell to 6.6 ng/ml when phenylalanine was 700 µmol/l (11.6 mg/100 ml), and an oral load of tetrahydrobiopterin produced no change in phenylalanine or tyrosine concentrations (Fig. 3), even though plasma biopterin concentrations rose during the test to 16 ng/ml. Dihydropteridine reductase activity in a dried blood spot was normal (174 µmol NADH/min/l, normal range 90–180 µmol/l).

A third patient with an initial concentration of 19.5 ng/ml was investigated elsewhere on a low phenylalanine diet and found to have a normal urine pterin pattern. The results of tests on these three patients indicated that the initial high biopterin values were due to the phenylalanine accumulation without deficiency of dihydropteridine reductase

Table 1 Plasma biopterins (mean (SD)) according to phenylalanine concentrations in infants with phenylketonuria due to phenylalanine hydroxylase deficiency. Cases 1 and 2 omitted

	No of cases	Plasma biopterin (ng/ml)	
		Mean	(SD)
Control infants (<2 months)	6	2.20	(0.93)
Phenylalanine range (µmol/l):			
0-399	7	3.16	(1.35)
400-799	23	6.54	(2.34)
800-1199	7	6.87	(3.09)
1200-1599	8	9.33	(3.40)
1600-1999	7	9.80	(1.76)
≤2000	24	9.79	(5.09)

One way analysis of variance $F=3.71, p < 0.01$.

Conversion: SI to traditional units—Phenylalanine: 1 mmol/l ≈ 16.5 mg/100 ml.

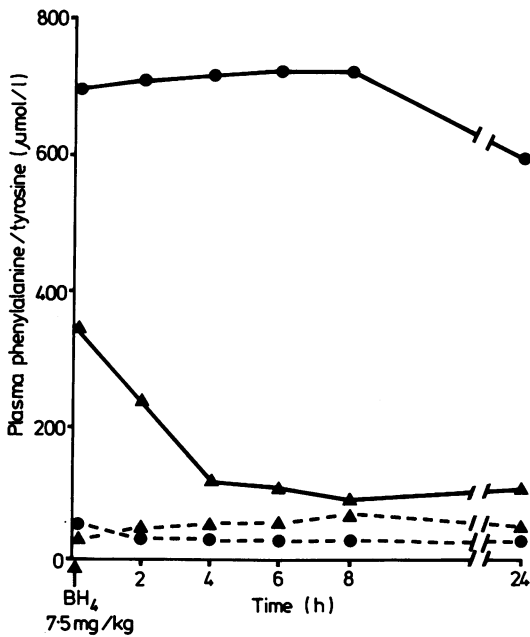

Fig. 3 Plasma phenylalanine (—) and tyrosine (---) concentrations after a single oral dose of tetrahydrobiopterin (BH_4) 7.5 mg/kg, in a patient with dihydropteridine reductase deficiency (\blacktriangle) and in a patient with phenylalanine hydroxylase deficiency (\bullet).

Conversion: SI to traditional units—Phenylalanine: 1 mmol/l=16.5 mg/100 ml.

activity. Investigations in two remaining patients, who proved to have abnormal biopterin metabolism, are described in more detail below.

Case 1: deficiency of dihydropteridine reductase activity. This infant had the highest initial plasma biopterin concentration (21.6 ng/ml) of the series. When retested after phenylalanine concentrations

had fallen to 240 μ mol/l plasma biopterin concentration was still high at 16.0 ng/ml. These results suggested a deficiency of dihydropteridine reductase activity, which was confirmed on further investigation. Urine pterin analysis gave a biopterin: neopterin: creatinine ratio of 814 (expected value 9–32, Dr A Niederwieser), and plasma phenylalanine concentration fell from 344 to 99 μ mol/l (5.7 to 1.6 mg/100 ml) while tyrosine rose from 39 to 65 μ mol/l in response to administration of tetrahydropteridine. There was no detectable dihydropteridine reductase activity in the liver, although phenylalanine hydroxylase activity was normal (Dr F Rey, Paris). Concentrations of total biopterin in CSF were raised (9–11 ng/ml) (Table 2) compared with the results found in the patients with neurological disorders (Table 3), but homovanillic (19 ng/ml) and 5-hydroxyindolacetic (3.5 ng/ml) acids were markedly reduced and were not increased by a single dose of tetrahydropteridine (7.5 mg/kg) (Table 2). The patient showed only minor clinical abnormalities (hypotonia and hypomobility).

Administration of L-dopa (10–12 mg/kg), carbidopa (as Sinemet-110), and 5-hydroxytryptophan 10–12 mg/kg from 3 months of age led to a rise in the amine metabolite concentrations in CSF (Table 2) and disappearance of the clinical signs. The patient made good developmental progress for the next 18 months, although intercurrent illness caused transient hypotonia. At 10 months of age neurotransmitter replacement therapy was temporarily withdrawn during a trial of monotherapy with tetrahydropteridine at a dose of 20 mg/kg/day. After five days the patient became grossly hypotonic and developed an acute oculogyric crisis, which was reversed within hours of reintroduction of L-dopa and 5-hydroxytryptophan. Despite a rise of plasma total biopterin concentration from 11 ng/ml to 73 ng/ml during administration of tetrahydropteridine there was no rise in the already raised CSF total biopterin concentration. Concentrations of homo-

Table 2 Neurochemical findings in case 1 with deficiency of dihydropteridine reductase activity. Treatment was with L-dopa, 5-hydroxytryptophan, and carbidopa and trial was of tetrahydrobiopterin 20 mg/kg/day

	Pretreatment		During treatment				Controls (n=6) Range
	Baseline	5 hours after tetrahydrobiopterin $\times 1$	L-Dopa, 5-hydroxytryptophan, and low phenylalanine diet			Tetrahydrobiopterin only 20 mg/kg	
Age (months)	3.1		3.5	6	9.5	10	1–48
Cerebrospinal fluid:							
Homovanillic acid (ng/ml)	17	16	40	91	102	37	160–60
5-Hydroxyindolacetic acid (ng/ml)	5	5	48	33	38	4	80–22
Biopterins (ng/ml)	—	—	—	9	11	10	3.1–4.4
Plasma biopterins (ng/ml)	21	27	16	—	11	73	0.5–4.8

Controls=six mentally retarded children without movement disorder.

Table 3 Plasma and CSF biopterins (ng/ml) in children with neurological disorders

Group	Age (yrs)	Biopterin (ng/ml)						
		Mean	Plasma			CSF		
			No	Mean	(SD)	No	Mean	(SD)
Mental retardation	4.2	19	1.8	(1.1)	6	3.7*	(0.6)	
Movement disorder	4.3	22	1.7	(0.8)	11	2.3*	(1.0)	
Torsion dystonia	12.1	5	1.7	(0.3)	4	3.6	(0.8)	
Inherited tics	12.1	4	2.2	(0.9)				
Total		50	1.78	(0.86)	21	2.9	(0.8)	

*Difference between CSF biopterin in children with mental retardation and those with movement disorder significant ($t=6.22$, $p<0.001$).

vanillic and 5-hydroxyindolacetic acids fell in accordance with the clinical observations (Table 2). Peripheral phenylalanine accumulation was, however, well controlled by a daily dose of 50 mg tetrahydrobiopterin, and this treatment was continued to obviate the need for a low phenylalanine diet. Full details of this patient have been published elsewhere.¹⁷

Despite good control of plasma phenylalanine concentration and continuing amine replacement therapy, developmental delay and regression occurred during the third year of life with deterioration in speech, impaired balance, ataxia, pinpoint pupils, recurrent absences, grand mal fits, increased tone, brisk jerks, and bilateral extensor plantar responses. Low total folate concentrations in serum and CSF suggest that the neurological deterioration was due to interference by the accumulating biopterins with folate metabolism,¹⁷ and administration of folinic acid (3 mg/day) halted the neurological deterioration.

Case 2: defective biopterin synthesis. A routine screening test for phenylketonuria was negative on the 10th day when the infant was receiving milk feeds but had developed diarrhoea. Raised phenylalanine concentrations, with an excess of phenylketones in the urine, was first noted at 4 months of age after the start of complete intravenous nutrition for persistent diarrhoea and failure to thrive. At this time the infant weighed only 3.6 kg, had recurrent fits, was severely delayed in development, and was noted to be grossly hypotonic with dyskinetic movements. Plasma biopterin concentration (2.2 ng/ml) was in the normal range despite plasma phenylalanine concentrations above 2000 $\mu\text{mol/l}$ (33 mg/100 ml) (Fig. 2). Withdrawal of intravenous treatment led to a fall of phenylalanine to 600 $\mu\text{mol/l}$ within 48 hours, but the infant suddenly collapsed and died. A dried blood spot obtained just before death showed no detectable biopterin activity, and

urine analysis by high performance liquid chromatography showed a low total biopterin of 0.475 $\mu\text{g/ml}$ and high normal neopterin of 5.325 $\mu\text{g/ml}$, with a biopterin:neopterin ratio of 1:11 (the normal for early infancy being 1:2, Professor J Blair). These findings suggested that the infant had a partial defect of biopterin synthesis. Permission for post mortem was refused.

Patients with neurological disorder. The mean (SD) plasma total biopterin concentration for the 50 children was 1.78 (0.86) ng/ml, almost identical to the mean (1.75 ng/ml) found in 10 normal children in a previous study.⁶ There were no significant differences between groups (Table 3), and there was no relation between age and plasma biopterin. Parents with dominantly inherited tics had similar plasma biopterin concentrations (mean 2.2 ng/ml) to their children. Two patients, one with mental retardation and one with movement disorder, had initial plasma biopterin results at the lower limit of detection (0.2 ng/ml). They were investigated by means of a phenylalanine load (Fig. 4, cases 1 and 2). Fasting plasma biopterin concentrations were 1.6 and 1.3 ng/ml, respectively, and the biopterin response to phenylalanine was normal. The low initial readings may have been due to artefact, perhaps caused by delay in specimen handling.

CSF total biopterin concentrations were generally higher (overall mean (SD) 2.9 (0.8) ng/ml) than plasma values (Table 3). With the exception of four children with torsion dystonia, however, patients with movement disorder had a significantly lower mean CSF biopterin (2.3 ng/ml) than the mean for six mentally retarded patients without movement disorder (3.7 ng/ml, $t=6.22$, $p<0.001$), and in five out of 11 patients with movement disorder CSF biopterin concentration was below plasma biopterin concentration. In five patients with torsion dystonia CSF biopterin concentrations were similar to those in children without movement disorder.

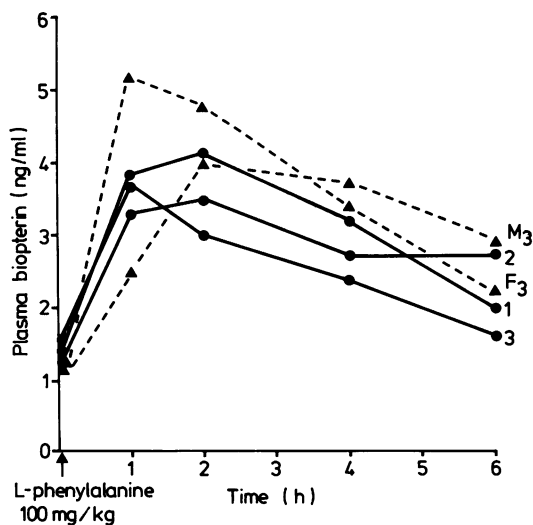

Fig. 4 Plasma biopterins after a load of L-phenylalanine, 100 mg/kg in three patients with neurological disorders: 1=extrapyramidal disorder, 2=mental retardation, and 3=torsion dystonia.

M₃ and F₃=mother and father of case 3. Plasma phenylalanine concentrations rose to between 420 and 601 μ mol/l (6.9 and 9.9 mg/100 ml).

Conversion: SI to traditional units—Phenylalanine: 1 mmol/l \approx 16.5 mg/100 ml.

Patient with torsion dystonia. One patient who had normal plasma and CSF biopterin concentrations was investigated in more detail because of a previous report⁹ of reduced hydroxylase cofactor activity in CSF in members of two families with dystonia.

This patient presented with left intermittent torticollis at 3 years of age. At 9 years he exhibited a severe dystonic posture of the neck, worse in the afternoon after eating, and disappearing during sleep. He also had long standing swallowing difficulty. He had a positive glabella tap and intermittent torsion dystonia of the left foot. Although he was of above average intelligence, he had great difficulty with handwriting, during which he adopted a bizarre posture. Neurological examination did not show any other abnormalities. On radiological examination there was atony and gross dilatation of the oesophagus with complete absence of peristalsis and failure of relaxation of the lower oesophageal sphincter. There was no reflux, and the picture resembled severe achalasia of the cardia. A fasting plasma phenylalanine:tyrosine ratio was <1 in patient and parents, indicating that there was no major impairment of phenylalanine hydroxylation in the liver. The response of plasma biopterin, phenylalanine,

and tyrosine concentrations to a phenylalanine load in patient and both parents (Fig. 4) was normal. Assay of dihydropteridine activity in a dried blood spot from the patient was also normal (102 μ mol NADH/min/ml). CSF homovanillic (38.5 ng/ml) and 5-hydroindolacetic (8.4 ng/ml) acids seemed to be low, although not as strikingly so as in the patient with deficiency of dihydropteridine activity. Therapeutic trials of Tegretol and of modest doses of Sinemet-110 (half a tablet thrice daily) with 5-hydroxytryptophan (20 mg thrice daily) produced no improvement in symptoms, and the latter treatment caused unacceptable drowsiness. Finally, bromocriptine in a dose of 2.5 mg twice a day abolished all symptoms over the course of four months. The swallowing difficulties gradually resolved, and the radiological abnormalities disappeared completely. After one year bromocriptine was withdrawn in a double blind manner over a six month period without causing clinical relapse, and six months later the patient remains perfectly well.

Discussion

The results reported here indicate that measurement of plasma total biopterin activity is of value in the diagnosis of patients with hyperphenylalanine due to tetrahydrobiopterin deficiency. The disadvantages of the crithidia assay are that some biopterin activity is lost in the course of the assay, it does not distinguish the different species of biopterin, and it does not measure neopterins. Newer methods of pterin analysis using high performance liquid chromatography^{18, 19} and radioimmunoassay²⁰ can be used to measure the different species of biopterin and neopterin. There will, however, be a continuing need for simple, sensitive, and cheap methods of biopterin measurement for routine testing of infants with phenylalanine accumulation. The crithidia assay can also be applied to dried blood spots, making routine testing even simpler.¹⁵

The results of the present study, showing that infants with raised plasma phenylalanine concentrations due to deficiency of phenylalanine hydroxylase activity have raised plasma biopterin concentrations in proportion to the hyperphenylalaninaemia are consistent with other studies.^{6, 15} Among 59 consecutive infants with persistently raised plasma phenylalanine concentrations two patients, both with plasma biopterin concentrations 2SD from the mean for patients with phenylalanine hydroxylase deficiency (allowing for variation in phenylalanine), proved to have defective biopterin metabolism.

The most useful investigations for confirmation or exclusion of defective biopterin metabolism depended upon whether the initial plasma biopterin

was 'high' or 'low'. In the patients with 'high' values measurement of dihydropteridine reductase activity, with repeat plasma biopterin measurement when phenylalanine had fallen to the normal range, enabled a firm diagnosis of dihydropteridine reductase deficiency to be made. In the presence of 'low' initial biopterins urine pterin analysis indicated a partial block in the conversion of neopterin to biopterin. This patient died before an oral load of tetrahydrobiopterin could be given, and the possibility that biopterin deficiency was due to profound malnutrition, rather than to an inborn error, cannot be excluded. The effects of disturbed biopterin metabolism on central dopamine and serotonin synthesis can be assessed by measurement of homovanillic and 5-hydroxyindolacetic acids in CSF. Although it was not performed here, it is also useful to measure the noradrenaline metabolite 3-methoxy 4-hydroxyphenylglycol.

In the patient with dihydropteridine reductase deficiency tetrahydrobiopterin in a single dose of 7.5 mg/kg, or a daily dose of 20 mg/kg, failed to control neurological symptoms or improve neurotransmitter amine synthesis and also failed to raise the already high CSF total biopterin concentration. These findings contrast with those reported in a study of a patient with defective synthesis of biopterins in whom it was possible to raise CSF biopterins by oral treatment with tetrahydrobiopterin,²¹ and another study showing that symptoms could be controlled in a patient with a synthesis defect.¹³

For the first 18 months of treatment our patient with dihydropteridine reductase deficiency made good progress on neurotransmitter replacement therapy, first in combination with a low phenylalanine diet, later with 50 mg/day tetrahydrobiopterin. Unfortunately, as in a similar patient described previously,²² progress during the third year of life was less satisfactory, with evidence of neurological deterioration due to a secondary defect of folate metabolism.¹⁷

In 50 children with neurological disease and without hyperphenylalaninaemia plasma biopterin concentrations were similar to those of healthy children,⁶ suggesting that in patients with normal phenylalanine concentrations general disturbance of biopterin metabolism is rarely the cause of progressive intellectual loss or extrapyramidal disturbance. CSF biopterin concentrations in children without movement disorder and children with torsion dystonia were similar to those in children with leukaemia (4.2 ng/ml) studied before treatment (unpublished data). CSF biopterin concentrations were lower in children with movement disorder other than torsion dystonia, a finding which can best be explained as due to anatomical or functional abnormality of the

brain areas normally contributing to CSF biopterin rather than as the result of a primary defect of biopterin metabolism.

Six adult patients with Huntington's chorea also had normal plasma biopterin and low CSF total biopterin concentrations (1.9 ng/ml) (unpublished observations). A study of 'hydroxylase cofactor activity' in CSF found concentrations equivalent to 20 $\mu\text{mol/l}$ tetrahydrobiopterin (4.2 ng/ml) in adult controls, and patients with movement disorder (Parkinson's disease and Huntington's chorea) again showed a reduction of 50% or more.⁸

Profoundly low CSF 'hydroxylase cofactor activity' has been reported in several members of two families with torsion dystonia.⁹ These patients did not manifest the degree of neurological disturbance that might have been expected² if tetrahydrobiopterin in the central nervous system had indeed been severely reduced. These results contrast with the normal crithidia results in the patients with torsion dystonia described here, although one in whom amine metabolite concentrations were measured did show reduced concentrations of dopamine and serotonin metabolites in the CSF, suggesting that interference with tyrosine and tryptophan hydroxylation might have been present. We speculate that an inhibitor of the aromatic hydroxylases is present in the CSF and brains of some patients with torsion dystonia, which, without direct interference in biopterin synthesis, reduces 'hydroxylase cofactor activity' and amine turnover. The association reported here of achalasia of the cardia with torsion dystonia and a disturbance of amine metabolism is of interest as the pathogenesis of both disorders remains a mystery.

We thank Dr M Tricklebank, Dr A Niederwieser, Dr Francoise Rey, and Professor J A Blair for their generous help with the investigations, Dr E Brett, Dr J Wilson, and Professor O H Wolff for allowing us to investigate their patients, Dr T Crow for donating the CSF from patients with Huntington's chorea, and Professor G Curzon for many helpful discussions. Financial support for this work was provided by the McAlpine Foundation and the Medical Research Council.

References

- 1 Kaufman S. Regulatory properties of pterin dependent hydroxylases. Variations on a theme. In: Usdin E, Weiner N, Youdim MBH, eds. *Function and regulation of monoamine enzymes*. McMillan Publications Ltd, 1981:165-73.
- 2 Smith I, Clayton BE, Wolff OH. New variant of phenylketonuria with progressive neurological illness unresponsive to phenylalanine restriction. *Lancet* 1975;i:1108-11.
- 3 Danks DM, Bartholome K, Clayton BE, et al. Malignant hyperphenylalaninaemia—current status. *Journal of Inherited Metabolic Disease* 1977;1:49-53.
- 4 Kaufman S, Holtzman NA, Milstien S, Butler IJ, Krumholz A. Phenylketonuria due to a deficiency of dihydropteridine reductase. *N Engl J Med* 1975;293:785-90.

- ⁵ Rey F, Harpey JP, Leeming RJ, Blair JA, Aicardi J, Rey J. Les hyperphenylalaninémies avec activité normale de la phenylalanine-hydroxylase. Le déficit en tetrahydrobiopterine et le déficit en dihydropteridine reductase. *Arch Fr Pediatr* 1977;**34**(suppl II):109–120.
- ⁶ Leeming RJ, Blair JA, Green A, Raine DN. Biopterin derivatives in normal and phenylketonuric patients after oral loads of L-phenylalanine, L-tyrosine and L-tryptophan. *Arch Dis Child* 1976;**51**:771–7.
- ⁷ Rey F, Saudubray JM, Leeming RJ, Niederwieser A, Curtius H-Ch, Rey J. Les déficits partiels en tetrahydrobiopterine. *Arch Fr Pediatr* 1983;**40**(suppl I):237–41.
- ⁸ Williams AC, Levine RA, Chase TN, Lovenberg W, Calne DB. CSF hydroxylase cofactor levels in some neurological diseases. *J Neurol Neurosurg Psychiatry* 1980;**43**:735–8.
- ⁹ Williams A, Eldridge R, Levine R, Lovenberg W, Paulson G. Low CSF hydroxylase cofactor (tetrahydrobiopterin) levels in inherited dystonia. *Lancet* 1979;ii:410–11.
- ¹⁰ Barford PA, Blair JA, Eggar C, Hamon C, Morar C, Whitburn SB. Tetrahydrobiopterin metabolism in the temporal lobe of patients dying with senile dementia of Alzheimer type. *J Neurol Neurosurg Psychiatry* 1984;**47**:136–8.
- ¹¹ Leeming RJ, Blair JA. The effects of pathological and normal physiological processes on biopterin derivative levels in man. *Clin Chim Acta* 1980;**108**:103–11.
- ¹² Niederwieser A, Curtius H-Ch, Gitzelmann R, et al. Excretion of pterins in phenylketonuria and phenylketonuria variants. *Helv Paediatr Acta* 1980;**35**:335–42.
- ¹³ Niederwieser A, Curtius H-Ch, Wang M, Leupold D. Atypical phenylketonuria with defective biopterin metabolism. Monotherapy with tetrahydrobiopterin or sepiapterin. Screening and study of biosynthesis in man. *Eur J Pediatr* 1982;**138**:110–2.
- ¹⁴ Arai N, Narisawa K, Hagakawa H, Tada K. Hyperphenylalaninaemia due to dihydropteridine reductase deficiency: diagnosis of enzyme assays on dried blood spots. *Pediatrics* 1982;**70**:426–30.
- ¹⁵ Leeming RJ, Barford PA, Blair JA, Smith I. Blood spots on Guthrie cards can be used for inherited tetrahydrobiopterin deficiency screening in hyperphenylalaninaemic infants. *Arch Dis Child* 1984;**59**:58–61.
- ¹⁶ Siefert WE, Fox JL, Butler IJ. Age effect on dopamine and serotonin metabolite levels in cerebrospinal fluid. *Ann Neurol* 1980;**8**:38–42.
- ¹⁷ Smith I, Hyland K, Kendall B, Leeming R. Clinical role of pteridine therapy in tetrahydrobiopterin deficiency. *Journal of Inherited Metabolic Disease* 1985;**8**(Suppl 1):39–45.
- ¹⁸ Fukushima M, Nixon JC. Analysis of reduced forms of biopterin in biological tissues and fluids. *Anal Biochem* 1980;**102**:176–88.
- ¹⁹ Lunte CE, Kissinger PT. Determination of pterins in biological samples by liquid chromatography/electrochemistry with dual electrode detector. *Anal Chem* 1983;**55**:1462–6.
- ²⁰ Nagatsu T, Yamaguchi T, Kato T. Biopterin in human brain and urine from controls and Parkinsonian patients: application of a new radio-immuno assay. *Clin Chim Acta* 1981;**109**:305–11.
- ²¹ Kaufman S, Kapatos G, McInnes RR, Schulman JD, Rizzo WB. Use of tetrahydrobiopterins in the treatment of hyperphenylalaninaemia due to defective synthesis of tetrahydrobiopterin: evidence that peripherally administered tetrahydropterins enter the brain. *Pediatrics* 1982;**70**:376–80.
- ²² Harpey JP. Les défauts de synthèse des biopterines: les déficits complets (reductase et synthetase). *Arch Fr Pediatr* 1983;**40**:231–5.

Correspondence to Dr I Smith, Institute of Child Health, 30 Guilford Street, London WC1N 1EH.

Received 18 October 1985