

Evaluation of Antifungal Volatile Compounds on the Basis of the Elongation Rate of a Single Hypha

HIDEAKI MATSUOKA,^{1*} YOSHIKAZU II,¹ YUKIHIRO TAKEKAWA,¹ AND TOHRU TERAOKA²

Department of Biotechnology, Faculty of Technology, Tokyo University of Agriculture and Technology, 2-24-16, Nakamachi, Koganei, Tokyo 184,¹ and Department of Plant Protection, Faculty of Agriculture, Tokyo University of Agriculture and Technology, 3-5-8, Saiwaicho, Fuchu, Tokyo 183,² Japan

Received 4 April 1990/Accepted 16 September 1990

A novel method is proposed for the evaluation of the activity of an antifungal agent administered as a gas. This system is composed of a batch-flow type reaction vessel, a gas flow system, and a microscopic observation system. The agar plate was prepared on the ceiling of the reaction vessel, and the mycelium of a fungus (*Aspergillus niger* or *Rhizoctonia solani*) was inoculated onto it. After preincubation at 25°C for 24 h, the reaction vessel was connected to the gas flow system. An appropriate hypha was selected, and its elongation rate was measured. Then a sample holder containing an antifungal compound was inserted into the reaction vessel from the side hole to saturate the atmosphere inside with its vapor. The retardation or inhibition of the hypha elongation was observed on a television monitor and recorded on a video tape recorder. The antifungal compound was then removed, and the reaction vessel was flushed with air. If the hypha lived, it began to elongate again. By this method, antifungal activity of seven odor compounds could be evaluated quantitatively within several hours.

To date, many antifungal compounds have been synthesized (6, 7, 11-15, 17, 19) or extracted from natural resources (1, 5, 6, 10-12, 15, 21). Formerly they were mainly applied to chemotherapy (15) or used as agricultural chemicals. Nowadays they are also used in various industrial products found in daily life because there is a greater public desire for cleanliness. Considering the variety of objects which should be protected from fungal growth, the use of antifungal reagents in the gas phase has been recognized as being more practical. Accordingly, the evaluation of antifungal activity in the gas phase has recently become more important than ever. The term antifungal activity refers to the inhibitory effect on the growth of fungi. Thus, the measurement of their growth is the basis for the evaluation of the antifungal activity. The growth process can be measured and evaluated from various viewpoints.

The amount of fungal biomass is determined by weighing the dry matter of fungi after separating it from a liquid medium (2, 8, 21). The appearance of colonies on a solid medium is a useful and widely used indicator of whether growth is inhibited (5, 11, 12). In order to evaluate the growth quantitatively, the increase in the colony diameter on an agar medium is used as an indicator of the increase in the fungal biomass (3, 9, 18). According to the definition proposed by Trinci (9), the radial growth rate of a fungal colony (K_r) is a function of the width of the peripheral zone of a colony (ω) and of the organism's specific growth rate (μ), i.e., $K_r = \omega\mu$. If ω is not altered by the experimental variable being considered, K_r is a reliable indicator of the specific growth rate. Its reliability was demonstrated, for example, in the evaluation of the effect of water activity on fungal growth (9). On the other hand, validamycin caused no effect on the cell division cycle but did inhibit the elongation of each cell compartment (18). These results indicate that cell division and the growth of each cell compartment should be considered separately.

ATP is often used as an indicator of the amount of biomass. Its reliability as an indicator of fungal biomass was assessed for *Trichoderma reesei* by demonstrating a good correlation with culture absorbance and culture dry weight (4). The chitin content expressed as glucosamine is also recognized as a good indicator of fungal biomass. Thus, the glucosamine was measured to estimate the fungal growth in plant materials on the basis of the color development after separation by ion-exchange chromatography (16). The growth of mold fungi on the surface of wood or wood products is difficult to evaluate. For such cases, the reflectance method was found effective and was applied to the evaluation of the effect of preservatives (20).

Of these methods mentioned above, determination of dry weight and measurement of colony diameter are most frequently used as useful and reliable methods for quantitative evaluation of fungal growth. The latter method is also applicable to the evaluation of volatile compounds in the gas phase. One disadvantage of this method is that it requires at least several days to obtain results. Therefore, a less-time-consuming method is required.

The present paper describes a rapid and simple method applicable to volatile compounds. The elongation of an appropriate single hypha was monitored by examination through a microscope. The feasibility of the present method was examined by applying several synthetic odor compounds. *Aspergillus niger* and *Rhizoctonia solani* were used as test fungi, since they are common and often studied.

MATERIALS AND METHODS

Organisms. *A. niger* (IFO 6661) was cultured on 3.9% potato dextrose agar (PDA) purchased from Nissui Seiyaku Co., Tokyo, Japan. *R. solani* was kindly donated by the National Institute of Agrobiological Resources, Tsukuba, Japan, and cultured on the same medium.

Materials. The following were used as volatile compounds to test the effectiveness of the present method: isoamyl salicylate (98%), cineole (90%), geraniol (98%), and limonene (95%) (kindly donated by Shiseido Laboratories Co., Yoko-

* Corresponding author.

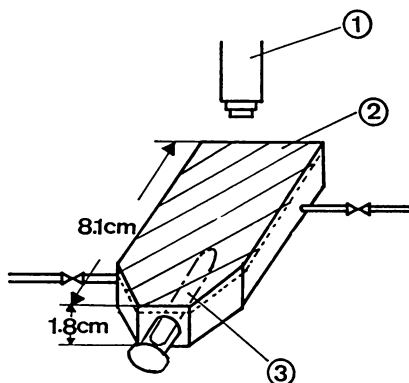

FIG. 1. Reaction vessel. Numbers in the figure refer to the following: 1, microscope; 2, PDA medium; 3, sample holder. Arrows indicate inlet and outlet of air.

hama, Japan) and benzaldehyde, cinnamic aldehyde, and ethyl salicylate (commercially available analytical grade materials). Distilled water was used throughout.

Measurement of hypha elongation. The reaction vessel is shown in Fig. 1. PDA was prepared on the ceiling of the reaction vessel to form an agar plate of 1- to 1.5-mm thickness. *A. niger* or *R. solani* was inoculated onto the PDA and incubated for 24 h at 25°C. In the reaction vessel there appeared only one colony, the fungal mass of which was estimated to be 0.5 mg of dry matter. An appropriate aerial hypha (one growing near the PDA surface) was selected from the colony. Its elongation was then observed with a microscope and displayed on a television screen. The time course of its elongation was recorded on a video tape recorder.

After confirming that the hypha elongated at a constant rate for about 1 h, a sample holder containing 50 μl of a volatile compound was inserted into the reaction vessel from the side hole. The elongation of the hypha was recorded. The sample holder was then removed, and the inside of the vessel was flushed with air at 30 ml min^{-1} . The observation of the hypha was continued. During a sequence of these reactions, morphological change of the hypha was also observed on the television screen.

Parameters which define the response of a single hypha. Typical patterns of the response curve are illustrated in Fig. 2. Before the exposure of the hypha to a volatile compound, the elongation rate is represented by the slope V_{PRE} . Upon the exposure of the compound, after a certain lag time the elongation first is retarded and then becomes another steady rate, which is given by the slope V_{EXPO} . This transient period is defined τ_{ON} . During the flushing with air, the elongation rate will change again (V_{POST}) after a certain lag time (τ_{OFF}). Figure 2A represents irreversible and complete inhibition of growth, which suggests the death of the hypha (fungicidal effect). In contrast, Fig. 2B shows fungistatic effect. A fungicidal effect is indicated only when V_{EXPO} is zero and τ_{OFF} is infinite. Figure 2C shows a less active effect than that seen in Fig. 2B and shows that the concentration of the reagent did not reach MIC.

RESULTS

Antifungal activity of odor compounds against *A. niger*. Initially, the antifungal activity of limonene was investigated. A hypha elongated at a constant rate of 2.0 $\mu\text{m min}^{-1}$

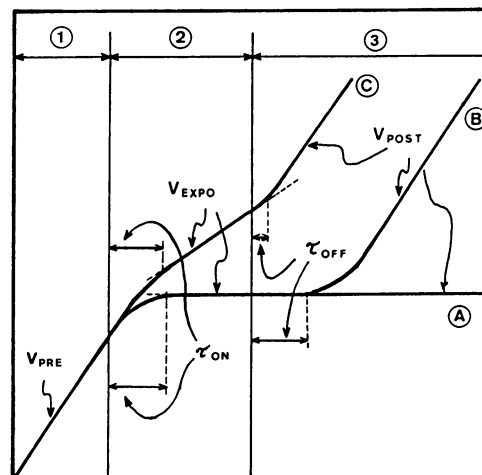

FIG. 2. Definition of parameters indicating the dynamic response of a single hypha to volatile compounds.

in air (Fig. 3A). When a sample holder containing limonene was inserted into the reaction vessel, the elongation stopped within 2 min. The exposure to limonene fumes was continued for 32 min. The sample holder was then removed, and the inside of the reaction vessel was flushed with air for 4.8 h. During the flushing, the hypha began to elongate again slightly. However, this elongation stopped 0.34 h later.

The antifungal activity of cineole is shown in Fig. 3B. Initially, the elongation rate was 1.9 $\mu\text{m min}^{-1}$. Upon exposure of the hypha to cineole, the elongation stopped after 0.2 h. The exposure was continued for 70 min. The inside of the reaction vessel was then flushed with air. The hypha did not elongate at all for the next 7 h.

Figure 3C, D, and E shows similar results obtained with benzaldehyde, cinnamic aldehyde, and geraniol, respectively. The delay time (τ_{ON}) was about 0.2 to 0.3 h in all cases except geraniol. Independent of the τ_{ON} value, the hypha did not elongate any more during flushing for 4.8 to 6.8 h. These results suggest a fungicidal effect, since no more elongation occurred during the experimental period.

On the other hand, the following examples show fungistatic effects. The effect of isoamyl salicylate on *A. niger* is shown in Fig. 3F. The elongation rate was initially 1.9 $\mu\text{m min}^{-1}$. During the exposure to isoamyl salicylate, the elongation was retarded to 1.5 $\mu\text{m min}^{-1}$. During the successive flushing with air, it decreased further. At the same time, the tip of the hypha divided into two branches, and each branch elongated at the same rate (0.9 $\mu\text{m min}^{-1}$, 46% of the initial rate).

The effect of ethyl salicylate on the elongation of an *A. niger* hypha is shown in Fig. 3G. Initially, the hypha elongated at 2.8 $\mu\text{m min}^{-1}$. When the sample holder containing ethyl salicylate was inserted into the reaction vessel, the elongation stopped within 1.7 h. After exposure for 6 h, the sample holder was removed, and the inside of the reaction vessel was flushed with air. After 2.4 h, the hypha began to elongate again. The elongation rate increased and finally reached 6.0 $\mu\text{m min}^{-1}$, which was greater (216%) than the initial rate.

Antifungal activity of odor compounds against *R. solani*. Figure 4A shows the effect of benzaldehyde on the elongation of an *R. solani* hypha. Initially, the elongation stopped immediately. After 2.0 h of exposure, the reaction vessel was flushed with air. The hypha did not elongate until 2.8 h

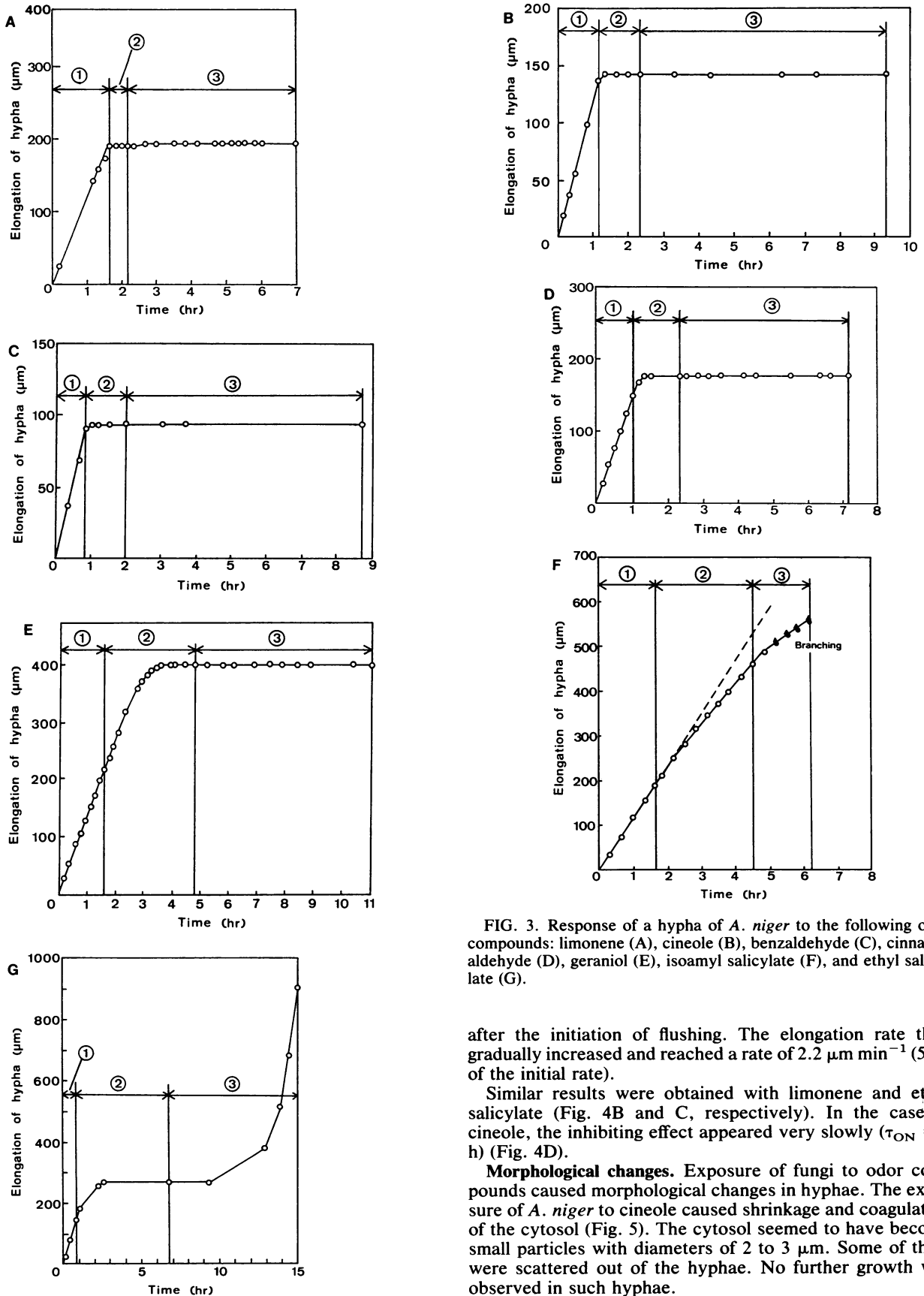

FIG. 3. Response of a hypha of *A. niger* to the following odor compounds: limonene (A), cineole (B), benzaldehyde (C), cinnamic aldehyde (D), geraniol (E), isoamyl salicylate (F), and ethyl salicylate (G).

after the initiation of flushing. The elongation rate then gradually increased and reached a rate of $2.2 \mu\text{m min}^{-1}$ (58% of the initial rate).

Similar results were obtained with limonene and ethyl salicylate (Fig. 4B and C, respectively). In the case of cineole, the inhibiting effect appeared very slowly ($\tau_{ON} = 2 \text{ h}$) (Fig. 4D).

Morphological changes. Exposure of fungi to odor compounds caused morphological changes in hyphae. The exposure of *A. niger* to cineole caused shrinkage and coagulation of the cytosol (Fig. 5). The cytosol seemed to have become small particles with diameters of 2 to 3 μm . Some of them were scattered out of the hyphae. No further growth was observed in such hyphae.

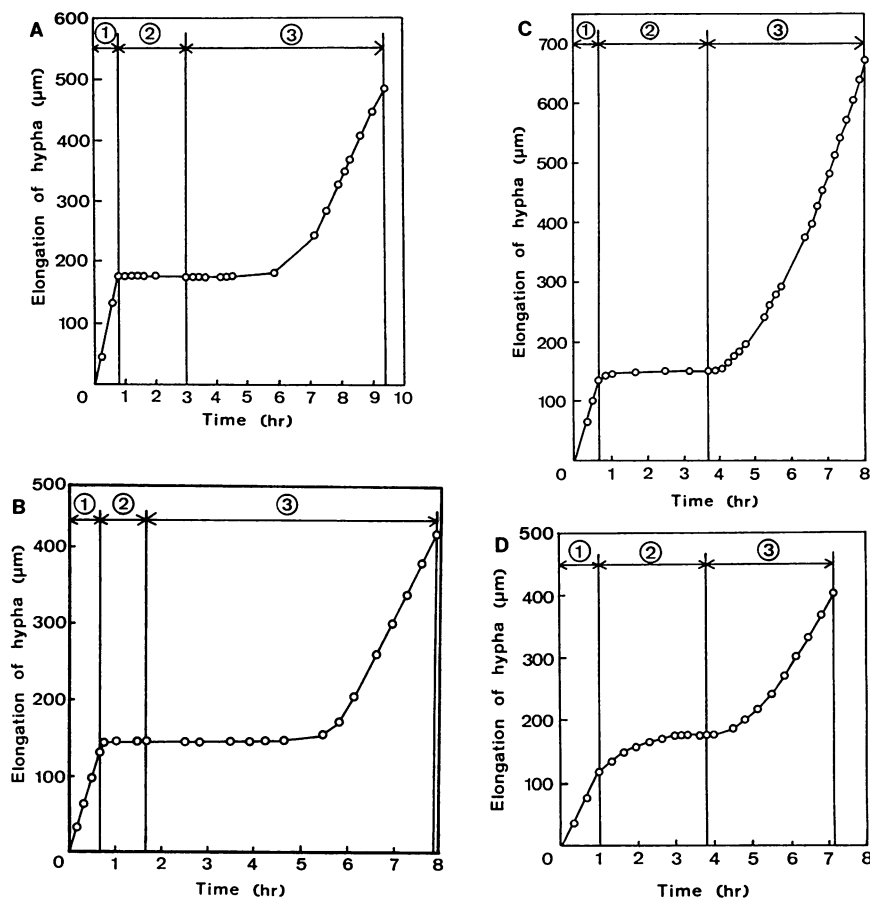

FIG. 4. Response of a hypha of *R. solani* to the following odor compounds: benzaldehyde (A), limonene (B), ethyl salicylate (C), and cineole (D).

On the other hand, the exposure of *A. niger* to ethyl salicylate caused extrusion of the cytosol (Fig. 6). The cytosol seemed to be extruded at the tip of the growing hypha and to become a spherical gel. This phenomenon, however, did not necessarily indicate death of the hypha. In fact, during the flushing with air, the elongation of the hypha started in the vicinity of the spherical gel.

Comparison of antifungal activities of odor compounds. When V_{EXPO}/V_{PRE} is zero, there is complete inhibition of hypha elongation. If the concentration of an odor compound in the gas phase can be controlled and adjusted to the minimum necessary to cause complete inhibition, that concentration should

correspond to the MIC determined in the liquid or solid phase. In the present experiments, the gas phase was saturated with odor compounds at 25°C. Estimated concentrations in the gas phase are listed in Tables 1 and 2. The actual values, though they have not yet been determined, should exceed the MIC, except of isoamyl salicylate for *A. niger*.

When V_{EXPO}/V_{PRE} is kept constant at zero, τ_{ON} is a promising indicator of the intensity of antifungal activity. A small τ_{ON} value indicates that inhibition occurs immediately; i.e., the fungicide is highly effective. In Table 1, odor compounds are listed according to the τ_{ON} value. In most cases, τ_{ON} was less than 1.0 h.

TABLE 1. Antifungal activities of odor compounds against *A. niger*

Odor compound	V_{PRE} ($\mu\text{m min}^{-1}$)	τ_{ON} (h)	$100 \times (V_{EXPO}/V_{PRE})$ (%)	τ_{OFF} (h)	$100 \times (V_{POST}/V_{PRE})$ (%)	C_{GAS}^a (nmol ml $^{-1}$)
Limonene	2.0	<0.03	0	>4.8	0 ^b	76
Cineole	1.9	0.2	0	>7	0	87
Benzaldehyde	1.8	0.2	0	>6.8	0	59
Cinnamic aldehyde	2.5	0.33	0	>4.8	0	1.1
Geraniol	2.3	2.0	0	>6.3	0	1.1
Isoamyl salicylate	1.9	0.57	75	0.23	46 ^c	0.28
Ethyl salicylate	2.8	1.7	0	2.4	216	2.9

^a Concentration of odor compound in the gas phase estimated from the vapor pressure at 25°C.

^b Slight growth occurred for a short time.

^c Branching occurred and both hyphae elongated at the same rate.

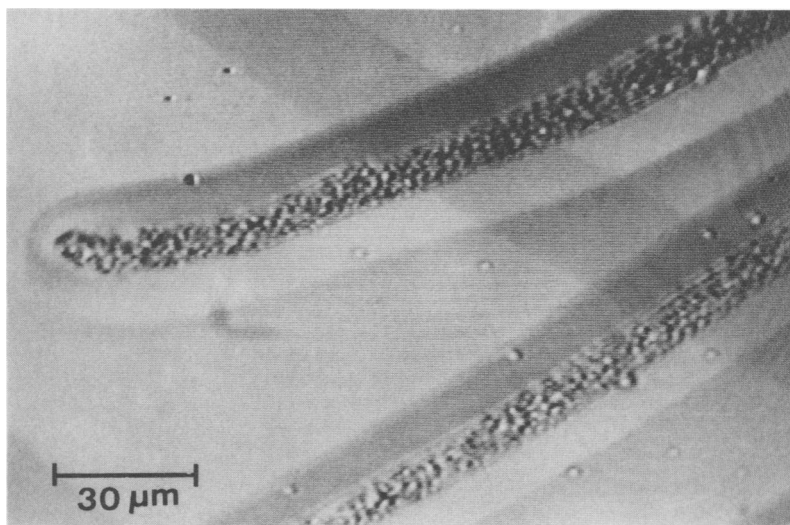

FIG. 5. Photograph of hyphae of *A. niger* after exposure to cineole.

It should be stressed that the complete inhibition mentioned above cannot necessarily be ascribed to the death of the hypha. It was often observed that hyphae began to elongate again after the removal of the odor compound by flushing with air. τ_{OFF} is considered to be another important indicator of how long the effect of exposure to odor compounds remains. If the odor compound incorporated in a hypha can hardly be decomposed metabolically or if some cellular functions once inhibited by the odor compound can hardly be recovered, τ_{OFF} should be a large value. If the fungus dies, τ_{OFF} is infinite and $V_{\text{POST}}/V_{\text{PRE}}$ is zero. In the cases of limonene, cineole, and benzaldehyde, τ_{OFF} was longer than the experimental period for *A. niger*, while it was shorter than 3 h for *R. solani*. These results indicate that *R. solani* has a higher capacity for surviving the inhibited state caused by these odor compounds.

DISCUSSION

In the present study, the dynamic growth process was observed in order to evaluate antifungal activity. By focusing our attention on a single hypha, the effectiveness of antifungal volatile compounds could be checked very rapidly. Thus, it is very useful for the screening of many substances for antifungal activity. This method is also applicable to the gas phase, in which the concentration of the reagent is very low.

In this procedure, the exposure to reagent and the flushing of it are performed successively. Thus, the antifungal activity can be evaluated with regard to how rapidly its effect appears and how long its effect remains. These observations

suggest the mechanisms of action for the reagents and present useful information for the evaluation of the reagents.

A more important factor to be considered is the acquisition of resistivity. It is well known that a fungus, once attacked by some reagent, becomes more resistive than it was initially. It might not necessarily involve a mutation at the gene level. In order to consider these properties in the assay, it is essential to repeat a sequence of reagent exposures and flushings. The present method, which is based on the continuous observation of the dynamic response of a single hypha, is thus considered a promising method for the application of such a procedure.

On the other hand, the problem of statistics should be considered. The measurement is performed on a single hypha arbitrarily selected from large numbers of mycelia. The results should not depend upon which hypha is selected. Therefore, it is necessary to precisely control, for example, the time course of preincubation of spores and inoculation conditions. Another important factor concerns at what time after germination the hypha should be measured, since the germination time is not the same for all spores, even if they were inoculated at the same time. These factors can be controlled only partially at the present time.

Under such insufficient conditions, however, the reproducibility has been estimated by comparing the results obtained from different hyphae. In the case of isoamyl salicylate, for instance, the antifungal activities defined by $V_{\text{EXPO}}/V_{\text{PRE}}$ measured on four hyphae agreed within $\pm 19\%$.

The present results are sufficiently informative for evaluating the feasibility of the present method. The present

TABLE 2. Summary of antifungal activity of odor compounds against *R. solani*

Odor compound	V_{PRE} ($\mu\text{m min}^{-1}$)	τ_{ON} (h)	$100 \times (V_{\text{EXPO}}/V_{\text{PRE}})$ (%)	τ_{OFF} (h)	$100 \times (V_{\text{POST}}/V_{\text{PRE}})$ (%)	C_{GAS}^a (nmol ml ⁻¹)
Benzaldehyde	3.8	<0.03	0	2.8	58	59
Limonene	3.3	0.10	0	2.97	62	76
Ethyl salicylate	3.4	0.42	0	0.33	94	2.9
Cineole	2.0	2.05	0	0.21	85	87

^a See Table 1, footnote a.

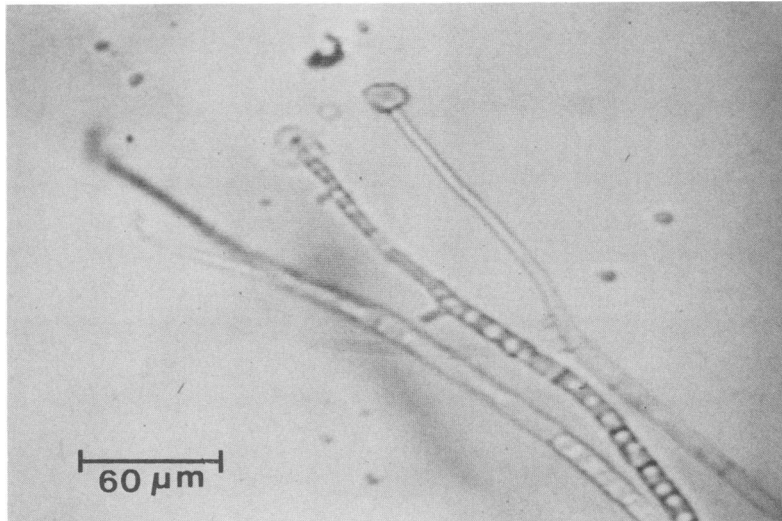

FIG. 6. Photograph of hyphae of *A. niger* after exposure to ethyl salicylate.

method, though the number of results is still very small, seems to be promising for quantitative analyses both in practical and in fundamental research fields. By using a prototype of a semiautomatic analyzing system, it has been shown that this method also works with at least 4 other fungal types (data not shown). Therefore, in order to accumulate data more efficiently, our efforts are now focused on the development of an automatic analyzing system based on the same principle.

ACKNOWLEDGMENTS

We express our gratitude to D. Hosokawa for valuable discussions and advice. We thank H. Ishii and A. Shinohara for their kind advice and technical support in treatment and measurement of odor compounds. We also thank S. Nakamura and Y. Terashima for their kind help and suggestions in the selection and supply of odor compounds.

LITERATURE CITED

- Azzouz, M. A., and L. B. Bullerman. 1982. Comparative antimycotic effects of selected herbs, spices, plant components and commercial antifungal agents. *J. Food Prot.* **45**:1298-1301.
- Fletcher, M. H., and A. P. J. Trinci. 1981. Effects on growth and macromolecular synthesis of starving *Neurospora crassa lys3* of lysine. *Trans. Br. Mycol. Soc.* **76**:237-242.
- Foster, S. A., and D. R. Walters. 1990. The effects of polyamine biosynthesis inhibitors on mycelial growth, enzyme activity and polyamine levels in the oat-infecting fungus *Pyrenophora avenae*. *J. Gen. Microbiol.* **136**:233-239.
- Gaunt, D. M., A. P. J. Trinci, and J. M. Lynch. 1985. The determination of fungal biomass using adenosine triphosphate. *Exp. Mycol.* **9**:174-178.
- Goi, H., S. Inouye, and Y. Iwanami. 1985. Antifungal activity of powdery black mustard, powdery wasabi (Japanese horseradish), and allyl iso-thiocyanate by gaseous contact. *J. Antibact. Antifung. Agents* **13**:199-204.
- Gunji, S., K. Arima, and T. Beppu. 1983. Screening of antifungal antibiotics according to activities inducing morphological abnormalities. *Agric. Biol. Chem.* **47**:2061-2069.
- Hegde, V. R., M. G. Patel, H. Wittreich, V. P. Gullo, M. S. Puar, and P. Bartner. 1989. Isolation and structure of an antifungal, Sch 40873. *J. Org. Chem.* **54**:2402-2404.
- Inch, J. M. M., A. M. Humphreys, and A. P. J. Trinci. 1986. Growth and blastospore formation by *Paecilomyces fumosoroseus*, a pathogen of brown planthopper (*Nilaparvata lugens*). *Trans. Br. Mycol. Soc.* **87**:215-222.
- Inch, J. M. M., and A. P. J. Trinci. 1987. Effects of water activity on growth and sporulation of *Paecilomyces farinosus* in liquid and solid media. *J. Gen. Microbiol.* **133**:247-252.
- Kitagawa, I., M. Kobayashi, B. W. Son, S. Suzuki, and Y. Kyogoku. 1989. Marine natural products. XIX. Pervicosides A, B, and C, lanostane-type triterpene-oligoglycoside sulfates from the sea cucumber *Holothuria pervicax*. *Chem. Pharm. Bull.* **37**:1230-1234.
- Kurita, N., M. Miyaji, R. Kurane, and Y. Takahara. 1981. Antifungal activity of components of essential oils. *Agric. Biol. Chem.* **45**:945-952.
- Moleyar, V., and P. Narasimham. 1986. Antifungal activity of some essential oil components. *Food Microbiol.* **3**:331-336.
- Nakano, M., Y. Nakajima, K. Iwatani, Y. Ikenishi, Y. Nakagawa, and K. Sugeno. 1989. Metabolism of the antimycotic agent, croconazole, in rabbits. *Drug Metab. Dispos.* **17**:323-329.
- Rao, A. V. R., P. R. Krishna, and J. S. Yadav. 1989. Stereoselective synthesis of (9Z, 15Z)-(11Z, 12S, 13S)-11-hydroxy-12,13-epoxy octadecadienoic acid: a constituent of rice plant infected with rice blast disease. *Tetrahedron Lett.* **30**:1669-1670.
- Ryley, J. F., R. G. Wilson, M. B. Gravestock, and J. P. Poyser. 1981. Experimental approaches to antifungal chemotherapy. *Adv. Pharmacol. Chemother.* **18**:49-176.
- Stahmann, M. A., P. Abramson, and L.-C. Wu. 1975. A chromatographic method for estimating fungal growth by glucosamine analysis of diseased tissues. *Biochem. Physiol. Pflanz.* **168**:S267-S276.
- Tacke, R., B. Becker, and D. Schomburg. 1989. The synthesis and the crystal and molecular structure of the fungicide bis(4-fluorophenyl)-methyl(1H1,2,4-triazol-1-yl-methyl)silane (flusilazole, DPX H 6573). *Appl. Organometallic Chem.* **3**:133-139.
- Trinci, A. P. J. 1985. Effect of validamycin A and L-sorbose on the growth and morphology of *Rhizoctonia cerealis* and *Rhizoctonia solani*. *Exp. Mycol.* **9**:20-27.
- Van Gestel, J. F. E., and M.-A. A. P. Van de Ven. 1984. Observations on the antispore activity of imazalil (enilconazole). *Pestic. Sci.* **15**:215-220.
- Wazny, J., P. Rudniewski, K. J. Krajewski, and T. Wazny. 1989. The reflectance method for testing the effectiveness of fungicides against surface mould growth on materials. I. *Wood. Sci. Technol.* **23**:179-189.
- Yoshida, S., S. Kasuga, N. Hayashi, T. Ushiroguchi, H. Matsuura, and S. Nakagawa. 1987. Antifungal activity of ajoene derived from garlic. *Appl. Environ. Microbiol.* **53**:615-617.